



**TECHNICAL EDUCATION AND SKILLS DEVELOPMENT AUTHORITY
(TESDA)**

BID DOCUMENTS

**Procurement of CMU
Boxes, Tools and
Equipment and
Mock-ups for the
Mobile Training
Laboratories (MTLs)**

2016-06

pl 7 m
abs

TABLE OF CONTENTS

| | |
|--|----|
| SECTION I. INVITATION TO BID | 2 |
| SECTION II. INSTRUCTIONS TO BIDDERS | 3 |
| SECTION III. BID DATA SHEET | 31 |
| SECTION IV. GENERAL CONDITIONS OF CONTRACT | 35 |
| SECTION V. SPECIAL CONDITIONS OF CONTRACT..... | 51 |
| SECTION VI. SCHEDULE OF REQUIREMENTS..... | 58 |
| SECTION VII. TECHNICAL SPECIFICATIONS..... | 61 |
| SECTION VIII. BIDDING FORMS | 62 |

27
pl
at

Section I. Invitation to Bid

96
7/20
AF



TECHNICAL EDUCATION AND SKILLS DEVELOPMENT AUTHORITY

ISO 9001 : 2008 CERTIFIED

Tatak ng Integridad, Serbisyonang Dekalidad, Kaagapay sa Pag-unlad



INVITATION TO BID

The Technical Education and Skills Development Authority (TESDA), through the TESDA Trust Fund Account, intends to apply the sum of Thirty Seven Million One Hundred Eighty Five Thousand One Hundred Forty Four Pesos and 048 Centavos (Php37,185,144.048) being the Approved Budget for the Contract (ABC), to payment for Procurement of CMU Boxes, Tools and Equipment and Mock-ups for the Mobile Training Laboratories (MTLs). Bids received in excess of the ABC shall be automatically rejected at the bid opening.

TESDA now invites suppliers to apply for eligibility and to bid for Procurement of CMU Boxes, Tools and Equipment and Mock-ups for the Mobile Training Laboratories (MTLs).

Bidders must have completed at least one (1) contract that is similar to the contract to be bid within five (5) year period from the date of the bid opening and whose value must be at least fifty percent (50%) of the ABC. The description of an eligible bidder is contained in the Bidding Documents, particularly in Section II of the Instructions to Bidders.

Bidding will be conducted through public bidding using a non-discretionary "pass/fail" criterion as prescribed by the Revised Implementing Rules and Regulations (RIRR) of Republic Act No. 9184, otherwise known as the Government Procurement Reform Act.

Only bids for all the items in each lot shall be accepted by the Procuring Entity. However, the bidder must bid for all lots subject of this procurement.

A complete set of Bidding Documents may be purchased by interested Bidders beginning on 08 April 2016 from the address written below and upon payment of a non-refundable fee relative to the cost of the Bidding Documents which shall be based on the following standard rates:

| Approved Budget for the Contract | Maximum Cost of Bidding Documents (in Philippine Peso) |
|--|---|
| 500,000 and below | 500.00 |
| More than 500,000 up to 1 Million | 1,000.00 |
| More than 1 Million up to 5 Million | 5,000.00 |
| More than 5 Million up to 10 Million | 10,000.00 |
| More than 10 Million up to 50 Million | 25,000.00 |
| More than 50 Million up to 500 Million | 50,000.00 |
| More than 500 Million | 75,000.00 |

The amount of the Bidding Documents shall depend on the ABC of the lot/s that will be participated in by the prospective Bidder. At any rate, the standard rates as provided by the Government Procurement Policy Board (GPPB) shall apply.

TESDA will hold a Pre-Bid Conference on 19 April 2016, 2:00 p.m. at the CSA Conference Room, 2nd Floor, TESDA Administration Building, Taguig City, which shall be open to all interested parties who have purchased the Bidding Documents.

Bids must be submitted to the BAC Secretariat, CSA Conference Room, 2nd Floor, TESDA Administration Building, Taguig City, on or before 06 May 2016 at 2:00 p.m. All bids must be accompanied by a bid security in any of the acceptable forms and in the amount stated in Clause 18 of Instructions to Bidders.

Bid opening shall be held on 06 May 2016 at 2:15 p.m. at the CSA Conference Room, 2nd Floor, TESDA Administration Building, Taguig City where the bids will be opened in the presence of the Bidders' representatives. Late bids shall not be accepted.

All particulars relative to the Eligibility Statement and Screening, Bid Security, Performance Security, Pre-Bid Conference, Evaluation of Bids, Post-Qualification and Award of Contract shall be governed by the pertinent provisions of Republic Act No. 9184 and its Revised Implementing Rules and Regulations.

TESDA reserves the right to accept or reject any bid, to annul the bidding process, and to reject all bids at any time prior to award of contract, without thereby incurring any liability to the affected bidder or bidders.

TESDA assumes no responsibility whatsoever to compensate or indemnify bidders for any expenses incurred in the preparation of their bids.

For further information, please refer to:

BAC Secretariat
3rd Floor, Procurement Division
TESDA Administration Building
South Luzon Expressway, Taguig City
Telefax: (02) 893-8296

(Sgd.) RD FRANCISCO B. JUCAR, JR.
BAC Chairperson

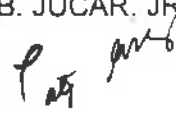
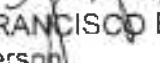

Section II. Instructions to Bidders

TABLE OF CONTENTS

| | |
|---|----|
| A. GENERAL..... | 5 |
| 1. Scope of Bid..... | 5 |
| 2. Source of Funds..... | 5 |
| 3. Corrupt, Fraudulent, Collusive, and Coercive Practices..... | 5 |
| 4. Conflict of Interest..... | 6 |
| 5. Eligible Bidders..... | 8 |
| 6. Bidder's Responsibilities..... | 9 |
| 7. Origin of Goods..... | 10 |
| 8. Subcontracts..... | 11 |
| B. CONTENTS OF BIDDING DOCUMENTS..... | 11 |
| 9. Pre-Bid Conference..... | 11 |
| 10. Clarification and Amendment of Bidding Documents..... | 12 |
| C. PREPARATION OF BIDS..... | 12 |
| 11. Language of Bid..... | 12 |
| 12. Documents Comprising the Bid: Eligibility and Technical Components..... | 12 |
| 13. Documents Comprising the Bid: Financial Component..... | 14 |
| 14. Alternative Bids..... | 15 |
| 15. Bid Prices..... | 15 |
| 16. Bid Currencies..... | 17 |
| 17. Bid Validity..... | 17 |
| 18. Bid Security..... | 17 |
| 19. Format and Signing of Bids..... | 20 |
| 20. Sealing and Marking of Bids..... | 20 |
| D. SUBMISSION AND OPENING OF BIDS..... | 21 |
| 21. Deadline for Submission of Bids..... | 21 |
| 22. Late Bids..... | 21 |
| 23. Modification and Withdrawal of Bids..... | 21 |
| 24. Opening and Preliminary Examination of Bids..... | 22 |
| E. EVALUATION AND COMPARISON OF BIDS..... | 23 |
| 25. Process to be Confidential..... | 23 |

7/21/14
af

| | | |
|-----|---|----|
| 26. | Clarification of Bids..... | 23 |
| 27. | Domestic Preference | 23 |
| 28. | Detailed Evaluation and Comparison of Bids..... | 24 |
| 29. | Post-Qualification | 25 |
| 30. | Reservation Clause..... | 26 |
| F. | AWARD OF CONTRACT | 27 |
| 31. | Contract Award | 27 |
| 32. | Signing of the Contract | 28 |
| 33. | Performance Security | 29 |
| 34. | Notice to Proceed | 30 |

96 7 W
af

A. General

1. Scope of Bid

- 1.1. The procuring entity named in the **BDS** (hereinafter referred to as the "Procuring Entity") wishes to receive bids for supply and delivery of the goods as described in Section VII. Technical Specifications (hereinafter referred to as the "Goods").
- 1.2. The name, identification, and number of lots specific to this bidding are provided in the **BDS**. The contracting strategy and basis of evaluation of lots is described in ITB Clause 28.

2. Source of Funds

The Procuring Entity has a budget or has applied for or received funds from the Funding Source named in the **BDS**, and in the amount indicated in the **BDS**. It intends to apply part of the funds received for the Project, as defined in the **BDS**, to cover eligible payments under the contract.

3. Corrupt, Fraudulent, Collusive, and Coercive Practices

- 3.1. Unless otherwise specified in the **BDS**, the Procuring Entity as well as the bidders and suppliers shall observe the highest standard of ethics during the procurement and execution of the contract. In pursuance of this policy, the Procuring Entity:
 - (a) defines, for purposes of this provision, the terms set forth below as follows:
 - (i) "corrupt practice" means behavior on the part of officials in the public or private sectors by which they improperly and unlawfully enrich themselves, others, or induce others to do so, by misusing the position in which they are placed, and includes the offering, giving, receiving, or soliciting of anything of value to influence the action of any such official in the procurement process or in contract execution; entering, on behalf of the government, into any contract or transaction manifestly and grossly disadvantageous to the same, whether or not the public officer profited or will profit thereby, and similar acts as provided in RA 3019.
 - (ii) "fraudulent practice" means a misrepresentation of facts in order to influence a procurement process or the execution of a contract to the detriment of the Procuring Entity, and includes collusive practices among Bidders (prior to or after bid submission) designed to establish bid prices at artificial, non-competitive levels and to deprive the Procuring Entity of the benefits of free and open competition.

- (iii) "collusive practices" means a scheme or arrangement between two or more Bidders, with or without the knowledge of the Procuring Entity, designed to establish bid prices at artificial, non-competitive levels.
- (iv) "coercive practices" means harming or threatening to harm, directly or indirectly, persons, or their property to influence their participation in a procurement process, or affect the execution of a contract;
- (v) "obstructive practice" is
 - (aa) deliberately destroying, falsifying, altering or concealing of evidence material to an administrative proceedings or investigation or making false statements to investigators in order to materially impede an administrative proceedings or investigation of the Procuring Entity or any foreign government/foreign or international financing institution into allegations of a corrupt, fraudulent, coercive or collusive practice; and/or threatening, harassing or intimidating any party to prevent it from disclosing its knowledge of matters relevant to the administrative proceedings or investigation or from pursuing such proceedings or investigation; or
 - (bb) acts intended to materially impede the exercise of the inspection and audit rights of the Procuring Entity or any foreign government/foreign or international financing institution herein.
- (b) will reject a proposal for award if it determines that the Bidder recommended for award has engaged in any of the practices mentioned in this Clause for purposes of competing for the contract.

3.2. Further, the Procuring Entity will seek to impose the maximum civil, administrative, and/or criminal penalties available under applicable laws on individuals and organizations deemed to be involved in any of the practices mentioned in ITB Clause 3.1(a).

3.3. Furthermore, the Funding Source and the Procuring Entity reserve the right to inspect and audit records and accounts of a bidder or supplier in the bidding for and performance of a contract themselves or through independent auditors as reflected in the GCC Clause 3.

4. Conflict of Interest

4.1. All Bidders found to have conflicting interests shall be disqualified to participate in the procurement at hand, without prejudice to the imposition of appropriate administrative, civil, and criminal sanctions. A Bidder may be considered to have conflicting interests with another Bidder in any of the

events described in paragraphs (a) through (c) below and a general conflict of interest in any of the circumstances set out in paragraphs (d) through (f) below:

- (a) A Bidder has controlling shareholders in common with another Bidder;
- (b) A Bidder receives or has received any direct or indirect subsidy from any other Bidder;
- (c) A Bidder has the same legal representative as that of another Bidder for purposes of this bid;
- (d) A Bidder has a relationship, directly or through third parties, that puts them in a position to have access to information about or influence on the bid of another Bidder or influence the decisions of the Procuring Entity regarding this bidding process. This will include a firm or an organization who lends, or temporarily seconds, its personnel to firms or organizations which are engaged in consulting services for the preparation related to procurement for or implementation of the project if the personnel would be involved in any capacity on the same project;
- (e) A Bidder submits more than one bid in this bidding process. However, this does not limit the participation of subcontractors in more than one bid; or
- (f) A Bidder who participated as a consultant in the preparation of the design or technical specifications of the Goods and related services that are the subject of the bid.

4.2. In accordance with Section 47 of the IRR of RA 9184, all Bidding Documents shall be accompanied by a sworn affidavit of the Bidder that it is not related to the Head of the Procuring Entity, members of the Bids and Awards Committee (BAC), members of the Technical Working Group (TWG), members of the BAC Secretariat, the head of the Project Management Office (PMO) or the end-user unit, and the project consultants, by consanguinity or affinity up to the third civil degree. On the part of the Bidder, this Clause shall apply to the following persons:

- (a) If the Bidder is an individual or a sole proprietorship, to the Bidder himself;
- (b) If the Bidder is a partnership, to all its officers and members;
- (c) If the Bidder is a corporation, to all its officers, directors, and controlling stockholders; and
- (d) If the Bidder is a joint venture (JV), the provisions of items (a), (b), or (c) of this Clause shall correspondingly apply to each of the members of the said JV, as may be appropriate.

Relationship of the nature described above or failure to comply with this Clause will result in the automatic disqualification of a Bidder.

967 N
df

5. Eligible Bidders

- 5.1. Unless otherwise provided in the BDS, the following persons shall be eligible to participate in this bidding:
- (a) Duly licensed Filipino citizens/sole proprietorships;
 - (b) Partnerships duly organized under the laws of the Philippines and of which at least sixty percent (60%) of the interest belongs to citizens of the Philippines;
 - (c) Corporations duly organized under the laws of the Philippines, and of which at least sixty percent (60%) of the outstanding capital stock belongs to citizens of the Philippines;
 - (d) Cooperatives duly organized under the laws of the Philippines, and of which at least sixty percent (60%) of the interest belongs to citizens of the Philippines; and
 - (e) Unless otherwise provided in the BDS, persons/entities forming themselves into a JV, *i.e.*, a group of two (2) or more persons/entities that intend to be jointly and severally responsible or liable for a particular contract: Provided, however, that Filipino ownership or interest of the joint venture concerned shall be at least sixty percent (60%).
- 5.2. Foreign bidders may be eligible to participate when any of the following circumstances exist, as specified in the BDS:
- (a) When a Treaty or International or Executive Agreement as provided in Section 4 of the RA 9184 and its IRR allow foreign bidders to participate;
 - (b) Citizens, corporations, or associations of a country, included in the list issued by the GPPB, the laws or regulations of which grant reciprocal rights or privileges to citizens, corporations, or associations of the Philippines;
 - (c) When the Goods sought to be procured are not available from local suppliers; or
 - (d) When there is a need to prevent situations that defeat competition or restrain trade.
- 5.3. Government corporate entities may be eligible to participate only if they can establish that they (a) are legally and financially autonomous, (b) operate under commercial law, and (c) are not dependent agencies of the GOP or the Procuring Entity.
- 5.4. Unless otherwise provided in the BDS, the Bidder must have completed at least one contract similar to the Project the value of which, adjusted to current

96 7/20
df

prices using the National Statistics Office consumer price index, must be at least equivalent to a percentage of the ABC stated in the **BDS**.

For this purpose, contracts similar to the Project shall be those described in the **BDS**, and completed within the relevant period stated in the Invitation to Bid and **ITB** Clause 12.1(a)(iii).

- 5.5. The Bidder must submit a computation of its Net Financial Contracting Capacity (NFCC), which must be at least equal to the ABC to be bid, calculated as follows:

$$\text{NFCC} = [(\text{Current assets minus current liabilities}) (K)] \text{ minus the value of all outstanding or uncompleted portions of the projects under ongoing contracts, including awarded contracts yet to be started coinciding with the contract for this Project.}$$

Where:

$K = 10$ for a contract duration of one year or less, 15 for a contract duration of more than one year up to two years, and 20 for a contract duration of more than two years.

The values of the bidder's current assets and current liabilities shall be based on the data submitted to the BIR, through its Electronic Filing and Payment System (EFPS).

6. Bidder's Responsibilities

- 6.1. The Bidder or its duly authorized representative shall submit a sworn statement in the form prescribed in Section VIII. Bidding Forms as required in **ITB** Clause 12.1(b)(iii).
- 6.2. The Bidder is responsible for the following:
- (a) Having taken steps to carefully examine all of the Bidding Documents;
 - (b) Having acknowledged all conditions, local or otherwise, affecting the implementation of the contract;
 - (c) Having made an estimate of the facilities available and needed for the contract to be bid, if any;
 - (d) Having complied with its responsibility to inquire or secure Supplemental/Bid Bulletin(s) as provided under **ITB** Clause 10.3.
 - (e) Ensuring that it is not "blacklisted" or barred from bidding by the GOP or any of its agencies, offices, corporations, or LGUs, including foreign government/foreign or international financing institution whose blacklisting rules have been recognized by the GPPB;

- (f) Ensuring that each of the documents submitted in satisfaction of the bidding requirements is an authentic copy of the original, complete, and all statements and information provided therein are true and correct;
- (g) Authorizing the Head of the Procuring Entity or its duly authorized representative/s to verify all the documents submitted;
- (h) Ensuring that the signatory is the duly authorized representative of the Bidder, and granted full power and authority to do, execute and perform any and all acts necessary and/or to represent the Bidder in the bidding, with the duly notarized Secretary's Certificate attesting to such fact, if the Bidder is a corporation, partnership, cooperative, or joint venture;
- (i) Complying with the disclosure provision under Section 47 of RA 9184 in relation to other provisions of RA 3019; and
- (j) Complying with existing labor laws and standards, in the case of procurement of services.

Failure to observe any of the above responsibilities shall be at the risk of the Bidder concerned.

- 6.3. The Bidder is expected to examine all instructions, forms, terms, and specifications in the Bidding Documents.
- 6.4. It shall be the sole responsibility of the Bidder to determine and to satisfy itself by such means as it considers necessary or desirable as to all matters pertaining to the contract to be bid, including: (a) the location and the nature of this Project; (b) climatic conditions; (c) transportation facilities; and (d) other factors that may affect the cost, duration, and execution or implementation of this Project.
- 6.5. The Procuring Entity shall not assume any responsibility regarding erroneous interpretations or conclusions by the prospective or eligible bidder out of the data furnished by the procuring entity.
- 6.6. The Bidder shall bear all costs associated with the preparation and submission of his bid, and the Procuring Entity will in no case be responsible or liable for those costs, regardless of the conduct or outcome of the bidding process.
- 6.7. Before submitting their bids, the Bidder is deemed to have become familiar with all existing laws, decrees, ordinances, acts and regulations of the Philippines which may affect this Project in any way.
- 6.8. The Bidder should note that the Procuring Entity will accept bids only from those that have paid the nonrefundable fee for the Bidding Documents at the office indicated in the Invitation to Bid.

7. Origin of Goods

27
9/7
21

Unless otherwise indicated in the **BDS**, there is no restriction on the origin of goods other than those prohibited by a decision of the United Nations Security Council taken under Chapter VII of the Charter of the United Nations, subject to **ITB** Clause 27.1.

8. Subcontracts

- 8.1. Unless otherwise specified in the **BDS**, the Bidder may subcontract portions of the Goods to an extent as may be approved by the Procuring Entity and stated in the **BDS**. However, subcontracting of any portion shall not relieve the Bidder from any liability or obligation that may arise from the contract for this Project.
- 8.2. Subcontractors must comply with the eligibility criteria and the documentary requirements specified in the **BDS**. In the event that any subcontractor is found by the Procuring Entity to be ineligible, the subcontracting of such portion of the Goods shall be disallowed.
- 8.3. The Bidder may identify the subcontractor to whom a portion of the Goods will be subcontracted at any stage of the bidding process or during contract implementation. If the Bidder opts to disclose the name of the subcontractor during bid submission, the Bidder shall include the required documents as part of the technical component of its bid.

B. Contents of Bidding Documents

9. Pre-Bid Conference

- 9.1. (a) If so specified in the **BDS**, a pre-bid conference shall be held at the venue and on the date indicated therein, to clarify and address the Bidders' questions on the technical and financial components of this Project.

*(b) The pre-bid conference shall be held at least twelve (12) calendar days before the deadline for the submission and receipt of bids. If the Procuring Entity determines that, by reason of the method, nature, or complexity of the contract to be bid, or when international participation will be more advantageous to the GOP, a longer period for the preparation of bids is necessary, the pre-bid conference shall be held at least thirty (30) calendar days before the deadline for the submission and receipt of bids, as specified in the **BDS**.*
- 9.2. Bidders are encouraged to attend the pre-bid conference to ensure that they fully understand the Procuring Entity's requirements. Non-attendance of the Bidder will in no way prejudice its bid; however, the Bidder is expected to know the changes and/or amendments to the Bidding Documents discussed during the pre-bid conference.
- 9.3. Any statement made at the pre-bid conference shall not modify the terms of the Bidding Documents unless such statement is specifically identified in writing as an amendment thereto and issued as a Supplemental/Bid Bulletin.

10. Clarification and Amendment of Bidding Documents

- 10.1. Bidders who have purchased the Bidding Documents may request for clarification on any part of the Bidding Documents for an interpretation. Such request must be in writing and submitted to the Procuring Entity at the address indicated in the **BDS** at least ten (10) calendar days before the deadline set for the submission and receipt of bids.
- 10.2. Supplemental/Bid Bulletins may be issued upon the Procuring Entity's initiative for purposes of clarifying or modifying any provision of the Bidding Documents not later than seven (7) calendar days before the deadline for the submission and receipt of bids. Any modification to the Bidding Documents shall be identified as an amendment.
- 10.3. Any Supplemental/Bid Bulletin issued by the BAC shall also be posted on the Philippine Government Electronic Procurement System (PhilGEPS) and the website of the Procuring Entity concerned, if available. It shall be the responsibility of all Bidders who secure the Bidding Documents to inquire and secure Supplemental/Bid Bulletins that may be issued by the BAC. However, Bidders who have submitted bids before the issuance of the Supplemental/Bid Bulletin must be informed and allowed to modify or withdraw their bids in accordance with **ITB** Clause 23.

C. Preparation of Bids

11. Language of Bid

The Bid, as well as all correspondence and documents relating to the bid exchanged by the Consultant and the Procuring Entity, shall be written in English. If the eligibility requirements or statements, the bids, and all other documents submitted to the BAC are in foreign language other than English, it must be accompanied by a translation of the documents in English. The documents shall be translated by the relevant foreign government agency, the foreign government agency authorized to translate documents, or a registered translator in the foreign bidder's country; and shall be authenticated by the appropriate Philippine foreign service establishment/post or the equivalent office having jurisdiction over the foreign bidder's affairs in the Philippines. The English translation shall govern, for purposes of interpretation of the bid.

12. Documents Comprising the Bid: Eligibility and Technical Components

12.1. Unless otherwise indicated in the **BDS**, the first envelope shall contain the following eligibility and technical documents:

- (a) Eligibility Documents –

Class "A" Documents:

N 7
H af

- (i) Registration certificate from the Securities and Exchange Commission (SEC), Department of Trade and Industry (DTI) for sole proprietorship, or Cooperative Development Authority (CDA) for cooperatives, or any proof of such registration as stated in the **BDS**;
- (ii) Mayor's permit issued by the city or municipality where the principal place of business of the prospective bidder is located;
- (iii) Statement of all its ongoing government and private contracts, including contracts awarded but not yet started, if any, whether similar or not similar in nature and complexity to the contract to be bid; and

Statement identifying the bidder's single largest completed contract similar to the contract to be bid, except under conditions provided for in Sec. 23.5.1.3 of the IRR, within the relevant period as provided in the **BDS**.

The statement shall include, for each contract, the following:

- (iii.1) name of the contract;
- (iii.2) date of the contract;
- (iii.3) kinds of Goods;
- (iii.4) amount of contract and value of outstanding contracts;
- (iii.5) date of delivery; and
- (iii.6) end user's acceptance or official receipt(s) issued for the contract, if completed.
- (iv) Audited financial statements, stamped "received" by the Bureau of Internal Revenue (BIR) or its duly accredited and authorized institutions, for the preceding calendar year, which should not be earlier than two (2) years from bid submission;
- (v) NFCC computation in accordance with **ITB** Clause 5.5; and
- (vi) Tax clearance per Executive Order 398, Series of 2005, as finally reviewed and approved by the BIR.

Class "B" Document:

- (vii) If applicable, the JVA in case the joint venture is already in existence, or duly notarized statements from all the potential joint venture partners stating that they will enter into and abide by the provisions of the JVA in the instance that the bid is successful.

Handwritten initials: N, Y, 9, 29

- (b) Technical Documents –
 - (i) Bid security in accordance with **ITB** Clause 18. If the Procuring Entity requires the bidders to submit the bid security in the form of:
 - (i.1) a bank draft/guarantee or an irrevocable letter of credit issued by a foreign bank, it shall be accompanied by a confirmation from a Universal or Commercial Bank; or
 - (i.2) a surety bond, it shall be accompanied by a certification by the Insurance Commission that the surety or insurance company is authorized to issue such instruments;
 - (ii) Conformity with technical specifications, as enumerated and specified in Sections VI and VII of the Bidding Documents; and
 - (iii) Sworn statement in accordance with Section 25.2(a)(iv) of the IRR of RA 9184 and using the form prescribed in Section VIII. Bidding Forms.

13. Documents Comprising the Bid: Financial Component

- 13.1. Unless otherwise stated in the **BDS**, the financial component of the bid shall contain the following:
 - (a) Financial Bid Form, which includes bid prices and the bill of quantities and the applicable Price Schedules, in accordance with **ITB** Clauses 15.1 and 15.4;
 - (b) If the Bidder claims preference as a Domestic Bidder or Domestic Entity, a certification from the DTI, SEC, or CDA issued in accordance with **ITB** Clause 27, unless otherwise provided in the **BDS**; and
 - (c) Any other document related to the financial component of the bid as stated in the **BDS**.
- 13.2. (a) Unless otherwise stated in the **BDS**, all bids that exceed the ABC shall not be accepted.
- (b) Unless otherwise indicated in the **BDS**, for foreign-funded procurement, a ceiling may be applied to bid prices provided the following conditions are met:
 - (i) Bidding Documents are obtainable free of charge on a freely accessible website. If payment of Bidding Documents is required by the procuring entity, payment could be made upon the submission of bids.

NT
 ulk
 ps

- (ii) The procuring entity has procedures in place to ensure that the ABC is based on recent estimates made by the responsible unit of the procuring entity and that the estimates reflect the quality, supervision and risk and inflationary factors, as well as prevailing market prices, associated with the types of works or goods to be procured.
- (iii) The procuring entity has trained cost estimators on estimating prices and analyzing bid variances.
- (iv) The procuring entity has established a system to monitor and report bid prices relative to ABC and engineer's/procuring entity's estimate.
- (v) The procuring entity has established a system to monitor and report bid prices relative to ABC and procuring entity's estimate. The procuring entity has established a monitoring and evaluation system for contract implementation to provide a feedback on actual total costs of goods and works.

14. Alternative Bids

Alternative Bids shall be rejected. For this purpose, alternative bid is an offer made by a Bidder in addition or as a substitute to its original bid which may be included as part of its original bid or submitted separately therewith for purposes of bidding. A bid with options is considered an alternative bid regardless of whether said bid proposal is contained in a single envelope or submitted in two (2) or more separate bid envelopes.

15. Bid Prices

- 15.1. The Bidder shall complete the appropriate Price Schedules included herein, stating the unit prices, total price per item, the total amount and the expected countries of origin of the Goods to be supplied under this Project.
- 15.2. The Bidder shall fill in rates and prices for all items of the Goods described in the Bill of Quantities. Bids not addressing or providing all of the required items in the Bidding Documents including, where applicable, Bill of Quantities, shall be considered non-responsive and, thus, automatically disqualified. In this regard, where a required item is provided, but no price is indicated, the same shall be considered as non-responsive, but specifying a "0" (zero) for the said item would mean that it is being offered for free to the Government.
- 15.3. The terms Ex Works (EXW), Cost, Insurance and Freight (CIF), Cost and Insurance Paid to (CIP), Delivered Duty Paid (DDP), and other trade terms used to describe the obligations of the parties, shall be governed by the rules prescribed in the current edition of the International Commercial Terms (INCOTERMS) published by the International Chamber of Commerce, Paris.
- 15.4. Prices indicated on the Price Schedule shall be entered separately in the following manner:

Handwritten initials and numbers:
 7 W
 M

- (a) For Goods offered from within the Procuring Entity's country:
 - (i) The price of the Goods quoted EXW (ex works, ex factory, ex warehouse, ex showroom, or off-the-shelf, as applicable), including all customs duties and sales and other taxes already paid or payable:
 - (i.1) on the components and raw material used in the manufacture or assembly of Goods quoted ex works or ex factory; or
 - (i.2) on the previously imported Goods of foreign origin quoted ex warehouse, ex showroom, or off-the-shelf and any Procuring Entity country sales and other taxes which will be payable on the Goods if the contract is awarded.
 - (ii) The price for inland transportation, insurance, and other local costs incidental to delivery of the Goods to their final destination.
 - (iii) The price of other (incidental) services, if any, listed in the **BDS**.

(b) For Goods offered from abroad:

- (i) Unless otherwise stated in the **BDS**, the price of the Goods shall be quoted DDP with the place of destination in the Philippines as specified in the **BDS**. In quoting the price, the Bidder shall be free to use transportation through carriers registered in any eligible country. Similarly, the Bidder may obtain insurance services from any eligible source country.
- (ii) The price of other (incidental) services, if any, listed in the **BDS**.

15.5. Prices quoted by the Bidder shall be fixed during the Bidder's performance of the contract and not subject to variation or price escalation on any account. A bid submitted with an adjustable price quotation shall be treated as non-responsive and shall be rejected, pursuant to **ITB** Clause 24.

All bid prices shall be considered as fixed prices, and therefore not subject to price escalation during contract implementation, except under extraordinary circumstances. Extraordinary circumstances refer to events that may be determined by the National Economic and Development Authority in accordance with the Civil Code of the Philippines, and upon the recommendation of the Procuring Entity. Nevertheless, in cases where the cost of the awarded contract is affected by any applicable new laws, ordinances, regulations, or other acts of the GOP, promulgated after the date of bid opening, a contract price adjustment shall be made or appropriate relief shall be applied on a no loss-no gain basis.

N 7 96
af

16. Bid Currencies

16.1. Prices shall be quoted in the following currencies:

- (a) For Goods that the Bidder will supply from within the Philippines, the prices shall be quoted in Philippine Pesos.
- (b) For Goods that the Bidder will supply from outside the Philippines, the prices may be quoted in the currency(ies) stated in the **BDS**. However, for purposes of bid evaluation, bids denominated in foreign currencies shall be converted to Philippine currency based on the exchange rate as published in the BSP reference rate bulletin on the day of the bid opening.

16.2. If so allowed in accordance with ITB Clause 16.1, the Procuring Entity for purposes of bid evaluation and comparing the bid prices will convert the amounts in various currencies in which the bid price is expressed to Philippine Pesos at the foregoing exchange rates.

16.3. Unless otherwise specified in the BDS, payment of the contract price shall be made in Philippine Pesos.

17. Bid Validity

17.1. Bids shall remain valid for the period specified in the **BDS** which shall not exceed one hundred twenty (120) calendar days from the date of the opening of bids.

17.2. In exceptional circumstances, prior to the expiration of the Bid validity period, the Procuring Entity may request Bidders to extend the period of validity of their bids. The request and the responses shall be made in writing. The bid security described in ITB Clause 18 should also be extended corresponding to the extension of the bid validity period at the least. A Bidder may refuse the request without forfeiting its bid security, but his bid shall no longer be considered for further evaluation and award. A Bidder granting the request shall not be required or permitted to modify its bid.

18. Bid Security

18.1. The bid security in the amount stated in the **BDS** shall be equal to the percentage of the ABC in accordance with the following schedule:

| Form of Bid Security | Amount of Bid Security (Equal to Percentage of the ABC) |
|---|--|
| (a) Cash or cashier's/manager's check issued by a Universal or Commercial Bank. | Two percent (2%) |

WT
ed
es

| | |
|---|---|
| (b) Bank draft/guarantee or irrevocable letter of credit issued by a Universal or Commercial Bank: Provided, however, that it shall be confirmed or authenticated by a Universal or Commercial Bank, if issued by a foreign bank. | |
| (c) Surety bond callable upon demand issued by a surety or insurance company duly certified by the Insurance Commission as authorized to issue such security. | Five percent (5%) |
| (d) Any combination of the items (a) to (c) above. | Proportionate to share of form with respect to total amount of security |
| (e) Bid Securing Declaration | No percentage required. |

For biddings conducted by LGUs, the procuring entity may also require bidders to submit bid securities in the form of cashier's/manager's check, bank draft/guarantee, or irrevocable letter of credit from other banks certified by the BSP as authorized to issue such financial statement.

The Bid Securing Declaration mentioned above is an undertaking which states, among others, that the bidder shall enter into contract with the procuring entity and furnish the performance security required under ITB Clause 33.2, from receipt of the Notice of Award, and committing to pay the corresponding fine, and be suspended for a period of time from being qualified to participate in any government procurement activity in the event it violates any of the conditions stated therein as provided in the guidelines issued by the GPPB.

- 18.2. The bid security should be valid for the period specified in the **BDS**. Any bid not accompanied by an acceptable bid security shall be rejected by the Procuring Entity as non-responsive.
- 18.3. No bid securities shall be returned to bidders after the opening of bids and before contract signing, except to those that failed or declared as post-disqualified, upon submission of a written waiver of their right to file a motion for reconsideration and/or protest. Without prejudice on its forfeiture, bid securities shall be returned only after the bidder with the Lowest Calculated and Responsive Bid has signed the contract and furnished the performance security, but in no case later than the expiration of the bid security validity period indicated in ITB Clause 18.2.
- 18.4. Upon signing and execution of the contract pursuant to ITB Clause 32, and the posting of the performance security pursuant to ITB Clause 33, the successful Bidder's bid security will be discharged, but in no case later than the bid security validity period as indicated in the ITB Clause 18.2.
- 18.5. The bid security may be forfeited:

Handwritten signature and initials in the bottom right corner of the page.

- (a) if a Bidder:
- (i) withdraws its bid during the period of bid validity specified in ITB Clause 17;
 - (ii) does not accept the correction of errors pursuant to ITB Clause 28.3(b);
 - (iii) fails to submit the requirements within the prescribed period or a finding against their veracity as stated in ITB Clause 29.2;
 - (iv) submission of eligibility requirements containing false information or falsified documents;
 - (v) submission of bids that contain false information or falsified documents, or the concealment of such information in the bids in order to influence the outcome of eligibility screening or any other stage of the public bidding;
 - (vi) allowing the use of one's name, or using the name of another for purposes of public bidding;
 - (vii) withdrawal of a bid, or refusal to accept an award, or enter into contract with the Government without justifiable cause, after the Bidder had been adjudged as having submitted the Lowest Calculated and Responsive Bid;
 - (viii) refusal or failure to post the required performance security within the prescribed time;
 - (ix) refusal to clarify or validate in writing its bid during post-qualification within a period of seven (7) calendar days from receipt of the request for clarification;
 - (x) any documented attempt by a bidder to unduly influence the outcome of the bidding in his favor;
 - (xi) failure of the potential joint venture partners to enter into the joint venture after the bid is declared successful; or
 - (xii) all other acts that tend to defeat the purpose of the competitive bidding, such as habitually withdrawing from bidding, submitting late Bids or patently insufficient bid, for at least three (3) times within a year, except for valid reasons.
- (b) if the successful Bidder:
- (i) fails to sign the contract in accordance with ITB Clause 32; or
 - (ii) fails to furnish performance security in accordance with ITB Clause 33.

19. Format and Signing of Bids

- 19.1. Bidders shall submit their bids through their duly authorized representative using the appropriate forms provided in Section VIII. Bidding Forms on or before the deadline specified in the **ITB** Clauses 21 in two (2) separate sealed bid envelopes, and which shall be submitted simultaneously. The first shall contain the technical component of the bid, including the eligibility requirements under **ITB** Clause 12.1, and the second shall contain the financial component of the bid.
- 19.2. Forms as mentioned in **ITB** Clause 19.1 must be completed without any alterations to their format, and no substitute form shall be accepted. All blank spaces shall be filled in with the information requested.
- 19.3. The Bidder shall prepare and submit an original of the first and second envelopes as described in **ITB** Clauses 12 and 13. In the event of any discrepancy between the original and the copies, the original shall prevail.
- 19.4. The bid, except for unamended printed literature, shall be signed, and each and every page thereof shall be initialed, by the duly authorized representative/s of the Bidder.
- 19.5. Any interlineations, erasures, or overwriting shall be valid only if they are signed or initialed by the duly authorized representative/s of the Bidder.

20. Sealing and Marking of Bids

- 20.1. Bidders shall enclose their original eligibility and technical documents described in **ITB** Clause 12 in one sealed envelope marked "ORIGINAL - TECHNICAL COMPONENT", and the original of their financial component in another sealed envelope marked "ORIGINAL - FINANCIAL COMPONENT", sealing them all in an outer envelope marked "ORIGINAL BID".
- 20.2. Each copy of the first and second envelopes shall be similarly sealed duly marking the inner envelopes as "COPY NO. ___ - TECHNICAL COMPONENT" and "COPY NO. ___ - FINANCIAL COMPONENT" and the outer envelope as "COPY NO. ___", respectively. These envelopes containing the original and the copies shall then be enclosed in one single envelope.
- 20.3. The original and the number of copies of the Bid as indicated in the **BDS** shall be typed or written in indelible ink and shall be signed by the bidder or its duly authorized representative/s.
- 20.4. All envelopes shall:
 - (a) contain the name of the contract to be bid in capital letters;
 - (b) bear the name and address of the Bidder in capital letters;

T N
af

- (c) be addressed to the Procuring Entity's BAC in accordance with ITB Clause 1.1;
 - (d) bear the specific identification of this bidding process indicated in the ITB Clause 1.2; and
 - (e) bear a warning "DO NOT OPEN BEFORE..." the date and time for the opening of bids, in accordance with ITB Clause 21.
- 20.5. If bids are not sealed and marked as required, the Procuring Entity will assume no responsibility for the misplacement or premature opening of the bid.

D. Submission and Opening of Bids

21. Deadline for Submission of Bids

Bids must be received by the Procuring Entity's BAC at the address and on or before the date and time indicated in the BDS.

22. Late Bids

Any bid submitted after the deadline for submission and receipt of bids prescribed by the Procuring Entity, pursuant to ITB Clause 21, shall be declared "Late" and shall not be accepted by the Procuring Entity.

23. Modification and Withdrawal of Bids

- 23.1. The Bidder may modify its bid after it has been submitted; provided that the modification is received by the Procuring Entity prior to the deadline prescribed for submission and receipt of bids. The Bidder shall not be allowed to retrieve its original bid, but shall be allowed to submit another bid equally sealed, properly identified, linked to its original bid marked as "TECHNICAL MODIFICATION" or "FINANCIAL MODIFICATION" and stamped "received" by the BAC. Bid modifications received after the applicable deadline shall not be considered and shall be returned to the Bidder unopened.
- 23.2. A Bidder may, through a Letter of Withdrawal, withdraw its bid after it has been submitted, for valid and justifiable reason; provided that the Letter of Withdrawal is received by the Procuring Entity prior to the deadline prescribed for submission and receipt of bids.
- 23.3. Bids requested to be withdrawn in accordance with ITB Clause 23.1 shall be returned unopened to the Bidders. A Bidder may also express its intention not to participate in the bidding through a letter which should reach and be stamped by the BAC before the deadline for submission and receipt of bids. A Bidder that withdraws its bid shall not be permitted to submit another bid, directly or indirectly, for the same contract.
- 23.4. No bid may be modified after the deadline for submission of bids. No bid may be withdrawn in the interval between the deadline for submission of bids and the expiration of the period of bid validity specified by the Bidder on the

Financial Bid Form. Withdrawal of a bid during this interval shall result in the forfeiture of the Bidder's bid security, pursuant to **ITB** Clause 18.5, and the imposition of administrative, civil and criminal sanctions as prescribed by RA 9184 and its IRR.

24. Opening and Preliminary Examination of Bids

- 24.1. The BAC shall open the first bid envelopes of Bidders in public as specified in the **BDS** to determine each Bidder's compliance with the documents prescribed in **ITB** Clause 12. For this purpose, the BAC shall check the submitted documents of each bidder against a checklist of required documents to ascertain if they are all present, using a non-discretionary "pass/fail" criterion. If a bidder submits the required document, it shall be rated "passed" for that particular requirement. In this regard, bids that fail to include any requirement or are incomplete or patently insufficient shall be considered as "failed". Otherwise, the BAC shall rate the said first bid envelope as "passed".
- 24.2. Unless otherwise specified in the BDS, immediately after determining compliance with the requirements in the first envelope, the BAC shall forthwith open the second bid envelope of each remaining eligible bidder whose first bid envelope was rated "passed". The second envelope of each complying bidder shall be opened within the same day. In case one or more of the requirements in the second envelope of a particular bid is missing, incomplete or patently insufficient, and/or if the submitted total bid price exceeds the ABC unless otherwise provided in **ITB** Clause 13.2, the BAC shall rate the bid concerned as "failed". Only bids that are determined to contain all the bid requirements for both components shall be rated "passed" and shall immediately be considered for evaluation and comparison.
- 24.3. Letters of withdrawal shall be read out and recorded during bid opening, and the envelope containing the corresponding withdrawn bid shall be returned to the Bidder unopened. If the withdrawing Bidder's representative is in attendance, the original bid and all copies thereof shall be returned to the representative during the bid opening. If the representative is not in attendance, the bid shall be returned unopened by registered mail. The Bidder may withdraw its bid prior to the deadline for the submission and receipt of bids, provided that the corresponding Letter of Withdrawal contains a valid authorization requesting for such withdrawal, subject to appropriate administrative sanctions.
- 24.4. If a Bidder has previously secured a certification from the Procuring Entity to the effect that it has previously submitted the above-enumerated Class "A" Documents, the said certification may be submitted in lieu of the requirements enumerated in **ITB** Clause 12.1(a), items (i) to (v).
- 24.5. In the case of an eligible foreign Bidder as described in **ITB** Clause 5, the Class "A" Documents described in **ITB** Clause 12.1(a) may be substituted with the appropriate equivalent documents, if any, issued by the country of the foreign Bidder concerned.

TN
A

- 24.6. Each partner of a joint venture agreement shall likewise submit the requirements in **ITB** Clauses 12.1(a)(i) and 12.1(a)(ii). Submission of documents required under **ITB** Clauses 12.1(a)(iii) to 12.1(a)(v) by any of the joint venture partners constitutes compliance.
- 24.7. The Procuring Entity shall prepare the minutes of the proceedings of the bid opening that shall include, as a minimum: (a) names of Bidders, their bid price, bid security, findings of preliminary examination; and (b) attendance sheet. The BAC members shall sign the abstract of bids as read.

E. Evaluation and Comparison of Bids

25. Process to be Confidential

- 25.1. Members of the BAC, including its staff and personnel, as well as its Secretariat and TWG, are prohibited from making or accepting any kind of communication with any bidder regarding the evaluation of their bids until the issuance of the Notice of Award, unless otherwise allowed in the case of **ITB** Clause 26.
- 25.2. Any effort by a bidder to influence the Procuring Entity in the Procuring Entity's decision in respect of bid evaluation, bid comparison or contract award will result in the rejection of the Bidder's bid.

26. Clarification of Bids

To assist in the evaluation, comparison, and post-qualification of the bids, the Procuring Entity may ask in writing any Bidder for a clarification of its bid. All responses to requests for clarification shall be in writing. Any clarification submitted by a Bidder in respect to its bid and that is not in response to a request by the Procuring Entity shall not be considered.

27. Domestic Preference

- 27.1. Unless otherwise stated in the **BDS**, the Procuring Entity will grant a margin of preference for the purpose of comparison of bids in accordance with the following:
- (a) The preference shall be applied when (i) the lowest Foreign Bid is lower than the lowest bid offered by a Domestic Bidder, or (ii) the lowest bid offered by a non-Philippine national is lower than the lowest bid offered by a Domestic Entity.
 - (b) For evaluation purposes, the lowest Foreign Bid or the bid offered by a non-Philippine national shall be increased by fifteen percent (15%).
 - (c) In the event that (i) the lowest bid offered by a Domestic Entity does not exceed the lowest Foreign Bid as increased, or (ii) the lowest bid offered by a non-Philippine national as increased, then the Procuring Entity shall award the contract to the Domestic Bidder/Entity at the

7
W
af

amount of the lowest Foreign Bid or the bid offered by a non-Philippine national, as the case may be.

- (d) If the Domestic Entity/Bidder refuses to accept the award of contract at the amount of the Foreign Bid or bid offered by a non-Philippine national within two (2) calendar days from receipt of written advice from the BAC, the Procuring Entity shall award to the bidder offering the Foreign Bid or the non-Philippine national, as the case may be, subject to post-qualification and submission of all the documentary requirements under these Bidding Documents.
- 27.2. A Bidder may be granted preference as a Domestic Entity subject to the certification from the DTI (in case of sole proprietorships), SEC (in case of partnerships and corporations), or CDA (in case of cooperatives) that the (a) sole proprietor is a citizen of the Philippines or the partnership, corporation, cooperative, or association is duly organized under the laws of the Philippines with at least seventy five percent (75%) of its interest or outstanding capital stock belonging to citizens of the Philippines, (b) habitually established in business and habitually engaged in the manufacture or sale of the merchandise covered by his bid, and (c) the business has been in existence for at least five (5) consecutive years prior to the advertisement and/or posting of the Invitation to Bid for this Project.
- 27.3. A Bidder may be granted preference as a Domestic Bidder subject to the certification from the DTI that the Bidder is offering unmanufactured articles, materials or supplies of the growth or production of the Philippines, or manufactured articles, materials, or supplies manufactured or to be manufactured in the Philippines substantially from articles, materials, or supplies of the growth, production, or manufacture, as the case may be, of the Philippines.

28. Detailed Evaluation and Comparison of Bids

- 28.1. The Procuring Entity will undertake the detailed evaluation and comparison of bids which have passed the opening and preliminary examination of bids, pursuant to **ITB** Clause 24, in order to determine the Lowest Calculated Bid.
- 28.2. The Lowest Calculated Bid shall be determined in two steps:
- (a) The detailed evaluation of the financial component of the bids, to establish the correct calculated prices of the bids; and
 - (b) The ranking of the total bid prices as so calculated from the lowest to the highest. The bid with the lowest price shall be identified as the Lowest Calculated Bid.
- 28.3. The Procuring Entity's BAC shall immediately conduct a detailed evaluation of all bids rated "passed," using non-discretionary pass/fail criteria. Unless otherwise specified in the **BDS**, the BAC shall consider the following in the evaluation of bids:

- (a) Completeness of the bid. Unless the ITB specifically allows partial bids, bids not addressing or providing all of the required items in the Schedule of Requirements including, where applicable, bill of quantities, shall be considered non-responsive and, thus, automatically disqualified. In this regard, where a required item is provided, but no price is indicated, the same shall be considered as non-responsive, but specifying a "0" (zero) for the said item would mean that it is being offered for free to the Procuring Entity; and
 - (b) Arithmetical corrections. Consider computational errors and omissions to enable proper comparison of all eligible bids. It may also consider bid modifications, if allowed in the **BDS**. Any adjustment shall be calculated in monetary terms to determine the calculated prices.
- 28.4. Based on the detailed evaluation of bids, those that comply with the above-mentioned requirements shall be ranked in the ascending order of their total calculated bid prices, as evaluated and corrected for computational errors, discounts and other modifications, to identify the Lowest Calculated Bid. Total calculated bid prices, as evaluated and corrected for computational errors, discounts and other modifications, which exceed the ABC shall not be considered, unless otherwise indicated in the **BDS**.
- 28.5. The Procuring Entity's evaluation of bids shall only be based on the bid price quoted in the Financial Bid Form.
- 28.6. Bids shall be evaluated on an equal footing to ensure fair competition. For this purpose, all bidders shall be required to include in their bids the cost of all taxes, such as, but not limited to, value added tax (VAT), income tax, local taxes, and other fiscal levies and duties which shall be itemized in the bid form and reflected in the detailed estimates. Such bids, including said taxes, shall be the basis for bid evaluation and comparison.

29. Post-Qualification

- 29.1. The Procuring Entity shall determine to its satisfaction whether the Bidder that is evaluated as having submitted the Lowest Calculated Bid (LCB) complies with and is responsive to all the requirements and conditions specified in ITB Clauses 5, 12, and 13.
- 29.2. Within a non-extendible period of three (3) calendar days from receipt by the bidder of the notice from the BAC that it submitted the LCB, the Bidder shall submit the following documentary requirements:
- (a) Latest income and business tax returns in the form specified in the **BDS**;
 - (b) Certificate of PhilGEPS Registration or PhilGEPS Registration Number if the procuring entity is a Philippine foreign office or post, provided that participating bidders should register with the PhilGEPS prior to bid opening; and

- (c) Other appropriate licenses and permits required by law and stated in the **BDS**.

Failure of the Bidder declared as Lowest Calculated Bid to duly submit the requirements under this Clause or a finding against the veracity of such shall be ground for forfeiture of the bid security and disqualification of the Bidder for award.

- 29.3. The determination shall be based upon an examination of the documentary evidence of the Bidder's qualifications submitted pursuant to ITB Clauses 12 and 13, as well as other information as the Procuring Entity deems necessary and appropriate, using a non-discretionary "pass/fail" criterion.
- 29.4. If the BAC determines that the Bidder with the Lowest Calculated Bid passes all the criteria for post-qualification, it shall declare the said bid as the Lowest Calculated Responsive Bid, and recommend to the Head of the Procuring Entity the award of contract to the said Bidder at its submitted price or its calculated bid price, whichever is lower.
- 29.5. A negative determination shall result in rejection of the Bidder's Bid, in which event the Procuring Entity shall proceed to the next Lowest Calculated Bid to make a similar determination of that Bidder's capabilities to perform satisfactorily. If the second Bidder, however, fails the post qualification, the procedure for post qualification shall be repeated for the Bidder with the next Lowest Calculated Bid, and so on until the Lowest Calculated Responsive Bid is determined for contract award.
- 29.6. Within a period not exceeding seven (7) calendar days from the date of receipt of the recommendation of the BAC, the Head of the Procuring Entity shall approve or disapprove the said recommendation. In the case of GOCCs and GFIs, the period provided herein shall be fifteen (15) calendar days.

30. Reservation Clause

- 30.1. Notwithstanding the eligibility or post-qualification of a Bidder, the Procuring Entity concerned reserves the right to review its qualifications at any stage of the procurement process if it has reasonable grounds to believe that a misrepresentation has been made by the said Bidder, or that there has been a change in the Bidder's capability to undertake the project from the time it submitted its eligibility requirements. Should such review uncover any misrepresentation made in the eligibility and bidding requirements, statements or documents, or any changes in the situation of the Bidder which will affect its capability to undertake the project so that it fails the preset eligibility or bid evaluation criteria, the Procuring Entity shall consider the said Bidder as ineligible and shall disqualify it from submitting a bid or from obtaining an award or contract.
- 30.2. Based on the following grounds, the Procuring Entity reserves the right to reject any and all bids, declare a failure of bidding at any time prior to the contract award, or not to award the contract, without thereby incurring any

liability, and make no assurance that a contract shall be entered into as a result of the bidding:

- (a) If there is *prima facie* evidence of collusion between appropriate public officers or employees of the Procuring Entity, or between the BAC and any of the Bidders, or if the collusion is between or among the bidders themselves, or between a Bidder and a third party, including any act which restricts, suppresses or nullifies or tends to restrict, suppress or nullify competition;
- (b) If the Procuring Entity's BAC is found to have failed in following the prescribed bidding procedures; or
- (c) For any justifiable and reasonable ground where the award of the contract will not redound to the benefit of the GOP as follows:
 - (i) If the physical and economic conditions have significantly changed so as to render the project no longer economically, financially or technically feasible as determined by the head of the procuring entity;
 - (ii) If the project is no longer necessary as determined by the head of the procuring entity; and
 - (iii) If the source of funds for the project has been withheld or reduced through no fault of the Procuring Entity.

30.3. In addition, the Procuring Entity may likewise declare a failure of bidding when:

- (a) No bids are received;
- (b) All prospective Bidders are declared ineligible;
- (c) All bids fail to comply with all the bid requirements or fail post-qualification; or
- (d) The Bidder with the Lowest Calculated Responsive Bid (LCRB) refuses, without justifiable cause to accept the award of contract, and no award is made.

F. Award of Contract

31. Contract Award

- 31.1. Subject to ITB Clause 29, the Procuring Entity shall award the contract to the Bidder whose bid has been determined to be the LCRB.
- 31.2. Prior to the expiration of the period of bid validity, the Procuring Entity shall notify the successful Bidder in writing that its bid has been accepted, through a Notice of Award received personally or sent by registered mail or

N 7
good
at

electronically, receipt of which must be confirmed in writing within two (2) days by the Bidder with the LCRB and submitted personally or sent by registered mail or electronically to the Procuring Entity.

- 31.3. Notwithstanding the issuance of the Notice of Award, award of contract shall be subject to the following conditions:
- (a) Submission of the valid JVA, if applicable, within ten (10) calendar days from receipt by the Bidder of the notice from the BAC that the Bidder has the LCRB;
 - (b) Posting of the performance security in accordance with ITB Clause 33;
 - (c) Signing of the contract as provided in ITB Clause 32; and
 - (d) Approval by higher authority, if required.
- 31.4. At the time of contract award, the Procuring Entity shall not increase or decrease the quantity of goods originally specified in Section VI. Schedule of Requirements.

32. Signing of the Contract

- 32.1. At the same time as the Procuring Entity notifies the successful Bidder that its bid has been accepted, the Procuring Entity shall send the Contract Form to the Bidder, which contract has been provided in the Bidding Documents, incorporating therein all agreements between the parties.
- 32.2. Within ten (10) calendar days from receipt of the Notice of Award, the successful Bidder shall post the required performance security and sign and date the contract and return it to the Procuring Entity.
- 32.3. The Procuring Entity shall enter into contract with the successful Bidder within the same ten (10) calendar day period provided that all the documentary requirements are complied with.
- 32.4. The following documents shall form part of the contract:
- (a) Contract Agreement;
 - (b) Bidding Documents;
 - (c) Winning bidder's bid, including the Technical and Financial Proposals, and all other documents/statements submitted;
 - (d) Performance Security;
 - (e) Credit line in accordance with ITB Clause 5.5, if applicable;
 - (f) Notice of Award of Contract; and

*W
of goods*

- (g) Other contract documents that may be required by existing laws and/or specified in the **BDS**.

33. Performance Security

- 33.1. To guarantee the faithful performance by the winning Bidder of its obligations under the contract, it shall post a performance security within a maximum period of ten (10) calendar days from the receipt of the Notice of Award from the Procuring Entity and in no case later than the signing of the contract.
- 33.2. The procuring entity shall prescribe at least two (2) acceptable forms of performance security taken from two (2) categories below that bidders may opt to use, denominated in Philippine Pesos and posted in favor of the Procuring Entity in an amount equal to the percentage of the total contract price in accordance with the following schedule:

| Form of Performance Security | Amount of Performance Security (Equal to Percentage of the Total Contract Price) |
|---|---|
| (a) Cash or cashier's/manager's check issued by a Universal or Commercial Bank. | Five percent (5%) |
| (b) Bank draft/guarantee or irrevocable letter of credit issued by a Universal or Commercial Bank: Provided, however, that it shall be confirmed or authenticated by a Universal or Commercial Bank, if issued by a foreign bank. | |
| (c) Surety bond callable upon demand issued by a surety or insurance company duly certified by the Insurance Commission as authorized to issue such security; and/or | Thirty percent (30%) |
| (d) Any combination of the foregoing. | Proportionate to share of form with respect to total amount of security |

- 33.3. Failure of the successful Bidder to comply with the above-mentioned requirement shall constitute sufficient ground for the annulment of the award and forfeiture of the bid security, in which event the Procuring Entity shall initiate and complete the post qualification of the second Lowest Calculated Bid. The procedure shall be repeated until the LCRB is identified and selected for contract award. However if no Bidder passed post-qualification, the BAC shall declare the bidding a failure and conduct a re-bidding with re-advertisement.

*W 7
af 966*

34. Notice to Proceed

- 34.1. Within three (3) calendar days from the date of approval of the contract by the appropriate government approving authority, the Procuring Entity shall issue its Notice to Proceed to the Bidder.
- 34.2. The contract effectivity date shall be provided in the Notice to Proceed by the Procuring Entity, which date shall not be later than seven (7) calendar days from the issuance of the Notice to Proceed.

35. Protest Mechanism

Decision of the procuring entity at any stage of the procurement process may be questioned in accordance with Section 55 of the revised Implementing Rules and Regulations of Republic Act 9184.

W 7
29/96

Section III. Bid Data Sheet

Bid Data Sheet

| ITB Clause | |
|------------|---|
| 1.1 | The Procuring Entity is Technical Education and Skills Development Authority (TESDA) . |
| 2 | <p>The Funding Source is the Government of the Philippines (GOP) through TESDA Trust Fund Account in the amount of Thirty Seven Million One Hundred Eighty Five Thousand One Hundred Forty Four Pesos and 048 Centavos (Php37,185,144.048).</p> <p>The name of the Project is Procurement of CMU Boxes, Tools and Equipment and Mock-ups for the Mobile Training Laboratories (MTLs).</p> |
| 3.1 | No further instructions. |
| 5.1 | <p>Additional Eligibility of the Bidders:</p> <ol style="list-style-type: none"> 1. The Bidder must have been in the business for at least five (5) years from the date of opening of bids; 2. If the bidder had a contract with TESDA, prior the bid opening for this project, said bidder must have satisfactorily performed its obligations without any adverse findings issued by competent authorities relative to the quality and cost of the goods supplied and delivered including period of delivery. 3. Pursuant to Section 23.5.1.3 of the Revised Implementing Rules and Regulations of Republic Act No. 9184, otherwise known as the Government Procurement Reform Act, which prescribes that the procuring entity may clarify in the Bidding Documents the definition or description of what it considers to be a similar project, a contract is similar to the contract to be bid if it involves goods of the same nature and complexity as those which are the subject of the public bidding concerned. In the case of this procurement, the goods subject of this public bidding pertain to CMU Boxes, Tools and Equipment and Mock-ups for the Mobile Training Laboratories (MTLs) of identified Technical Vocational Institutes (TVIs) as recipients of Mobile Training Laboratories (MTLs) Project. As such, the goods covered under the completed single contract of the bidder which must be equivalent to at least fifty percent (50%) of the ABC must have the same major categories of goods subject of this public bidding for the said contract to qualify as a contract similar to the contract to be bid. |

| | |
|--------------|---|
| | 4. The bidder must submit its clearances from the National Labor Relations Commission (NLRC), Department of Labor and Employment (DOLE), Pag-ibig Fund, Social Security System (SSS) and Philippine Health Insurance Corporation (PhilHealth) during the bid opening as part of the eligibility requirements. Said clearances must be issued within three (3) months from the date of the bid opening. |
| 5.2 | None of the circumstances mentioned in the ITB Clause exists in this Project. Foreign bidders, subject to ITB Clause 5.2(b), may participate in this Project. |
| 5.4 | The Bidder must have completed, within the period specified in the Invitation to Bid and ITB Clause 12.1(a)(iii), a single contract that is similar to this Project, equivalent to at least fifty percent (50%) of the ABC. |
| 7 | No further instructions. |
| 8.1 | Subcontracting is not allowed |
| 8.2 | Not applicable. |
| 9.1 | The Procuring Entity will hold a pre-bid conference for this Project on 19 April 2016, 2:00 p.m. at the CSA Conference Room, 2nd Floor, TESDA Administration Building, Taguig City. |
| 10.1 | The Procuring Entity's address is: Technical Education and Skills Development Authority East Service Road South Luzon Expressway Taguig City, Metro Manila Tel/Fax No. 893-8296 |
| 12.1(a) | No further instructions. |
| 12.1(a)(i) | No other acceptable proof of registration is recognized. |
| 12.1(a)(iii) | The statement of all ongoing government and private contracts shall include all such contracts within the last five (5) years prior to the deadline for the submission and receipt of bids. |
| 13.1 | No additional requirements. |
| 13.1(b) | No further instructions. |
| 13.2 | The ABC is Php37,185,144.048 . Any bid with a financial component |

| | |
|--------------|--|
| | exceeding this amount shall not be accepted. |
| 15.4(a)(iii) | No incidental services are required. |
| 15.4(b) | Not applicable |
| 16.1(b) | The Bid prices for Goods supplied from outside of the Philippines shall be quoted in Philippine Pesos. |
| 16.3 | Not applicable. |
| 17.1 | Bids will be valid for one hundred twenty (120) calendar days. |
| 18.1 | The bid security shall be in the following amount: <ul style="list-style-type: none"> 1. 2% of ABC, if bid security is in cash, cashier's/manager's check, bank draft/guarantee or irrevocable letter of credit (depending on the lot/s); 2. 5% of ABC, if bid security is in Surety Bond (depending on the lot/s); 3. Bid Securing Declaration pursuant to GPPB Circular No. 01-2014 issued on 23 May 2014; or 4. Any combination of the foregoing proportionate to the share of form with respect to total amount of security. |
| 18.2 | The bid security shall be valid for one hundred twenty (120) calendar days. |
| 20.3 | Each Bidder shall submit one (1) original and three (3) copies of the first and second components of its bid. |
| 21 | The address for submission of bids is: <p style="text-align: center;">TECHNICAL EDUCATION AND SKILLS DEVELOPMENT AUTHORITY RD FRANCISCO B. JUCAR, JR. Chairperson, BAC TESDA Complex, TESDA Administration Building East Service Road, SLEX Taguig City, Philippines</p> <p>The deadline for submission of bids is 06 May 2016 at 2:00 p.m.</p> |
| 24.1 | The place of bid opening is: <p style="text-align: center;">CSA Conference Room, 2nd Floor, TESDA Administration Building Taguig City</p> |

| | |
|---------|--|
| | The date and time of bid opening is 06 May 2016 at 2:15 p.m. |
| 24.2 | No further instructions. |
| 27.1 | No further instructions. |
| 28.3 | The bidding shall be done by lot. There are eighteen (18) lots. Only bids for all the items in each lot/qualification shall be accepted by the Procuring Entity. Bidders may bid for multiple lot/s qualifications where they think they are capable of supplying. Evaluation and award of contract will be undertaken depending on whatever is most advantageous to the government in terms of technical specifications and costs. |
| 28.3(b) | Bid modification is not allowed. |
| 28.4 | No further instructions. |
| 29.2(a) | Only tax returns filed and taxes paid through the BIR Electronic Filing and Payments System (EFPS) shall be accepted. NOTE: The latest income and business tax returns are those within the last six (6) months preceding the date of the submission of bid. |
| 29.2(b) | <i>List licenses and permits relevant to the Project and the corresponding law requiring it.</i> |
| 32.4(g) | <i>List additional contract documents relevant to the Project that may be required by existing laws and/or the Procuring Entity.</i> |

2
2

Section IV. General Conditions of Contract

TABLE OF CONTENTS

| | |
|--|----|
| 1. DEFINITIONS..... | 37 |
| 2. CORRUPT, FRAUDULENT, COLLUSIVE, AND COERCIVE PRACTICES..... | 38 |
| 3. INSPECTION AND AUDIT BY THE FUNDING SOURCE | 39 |
| 4. GOVERNING LAW AND LANGUAGE..... | 39 |
| 5. NOTICES | 39 |
| 6. SCOPE OF CONTRACT | 40 |
| 7. SUBCONTRACTING | 40 |
| 8. PROCURING ENTITY'S RESPONSIBILITIES | 40 |
| 9. PRICES..... | 40 |
| 10. PAYMENT..... | 41 |
| 11. ADVANCE PAYMENT AND TERMS OF PAYMENT..... | 41 |
| 12. TAXES AND DUTIES..... | 42 |
| 13. PERFORMANCE SECURITY | 42 |
| 14. USE OF CONTRACT DOCUMENTS AND INFORMATION..... | 43 |
| 15. STANDARDS..... | 43 |
| 16. INSPECTION AND TESTS | 43 |
| 17. WARRANTY..... | 44 |
| 18. DELAYS IN THE SUPPLIER'S PERFORMANCE..... | 44 |
| 19. LIQUIDATED DAMAGES | 45 |
| 20. SETTLEMENT OF DISPUTES..... | 45 |
| 21. LIABILITY OF THE SUPPLIER | 46 |
| 22. FORCE MAJEURE..... | 46 |
| 23. TERMINATION FOR DEFAULT | 46 |
| 24. TERMINATION FOR INSOLVENCY..... | 47 |
| 25. TERMINATION FOR CONVENIENCE | 47 |



| | |
|---|----|
| 26. TERMINATION FOR UNLAWFUL ACTS..... | 48 |
| 27. PROCEDURES FOR TERMINATION OF CONTRACTS | 48 |
| 28. ASSIGNMENT OF RIGHTS | 49 |
| 29. CONTRACT AMENDMENT..... | 49 |
| 30. APPLICATION..... | 50 |

*W
T
per
af*

1. Definitions

- 1.1. In this Contract, the following terms shall be interpreted as indicated:
- (a) "The Contract" means the agreement entered into between the Procuring Entity and the Supplier, as recorded in the Contract Form signed by the parties, including all attachments and appendices thereto and all documents incorporated by reference therein.
 - (b) "The Contract Price" means the price payable to the Supplier under the Contract for the full and proper performance of its contractual obligations.
 - (c) "The Goods" means all of the supplies, equipment, machinery, spare parts, other materials and/or general support services which the Supplier is required to provide to the Procuring Entity under the Contract.
 - (d) "The Services" means those services ancillary to the supply of the Goods, such as transportation and insurance, and any other incidental services, such as installation, commissioning, provision of technical assistance, training, and other such obligations of the Supplier covered under the Contract.
 - (e) "GCC" means the General Conditions of Contract contained in this Section.
 - (f) "SCC" means the Special Conditions of Contract.
 - (g) "The Procuring Entity" means the organization purchasing the Goods, as named in the SCC.
 - (h) "The Procuring Entity's country" is the Philippines.
 - (i) "The Supplier" means the individual contractor, manufacturer distributor, or firm supplying/manufacturing the Goods and Services under this Contract and named in the SCC.
 - (j) The "Funding Source" means the organization named in the SCC.
 - (k) "The Project Site," where applicable, means the place or places named in the SCC.
 - (l) "Day" means calendar day.
 - (m) The "Effective Date" of the contract will be the date of receipt by the Supplier of the Notice to Proceed or the date provided in the Notice to Proceed. Performance of all obligations shall be reckoned from the Effective Date of the Contract.

7
W pd
W

- (n) "Verified Report" refers to the report submitted by the Implementing Unit to the Head of the Procuring Entity setting forth its findings as to the existence of grounds or causes for termination and explicitly stating its recommendation for the issuance of a Notice to Terminate.

2. Corrupt, Fraudulent, Collusive, and Coercive Practices

2.1. Unless otherwise provided in the SCC, the Procuring Entity as well as the bidders, contractors, or suppliers shall observe the highest standard of ethics during the procurement and execution of this Contract. In pursuance of this policy, the Procuring Entity:

- (a) defines, for the purposes of this provision, the terms set forth below as follows:
 - (i) "corrupt practice" means behavior on the part of officials in the public or private sectors by which they improperly and unlawfully enrich themselves, others, or induce others to do so, by misusing the position in which they are placed, and it includes the offering, giving, receiving, or soliciting of anything of value to influence the action of any such official in the procurement process or in contract execution; entering, on behalf of the Government, into any contract or transaction manifestly and grossly disadvantageous to the same, whether or not the public officer profited or will profit thereby, and similar acts as provided in Republic Act 3019.
 - (ii) "fraudulent practice" means a misrepresentation of facts in order to influence a procurement process or the execution of a contract to the detriment of the Procuring Entity, and includes collusive practices among Bidders (prior to or after bid submission) designed to establish bid prices at artificial, non-competitive levels and to deprive the Procuring Entity of the benefits of free and open competition.
 - (iii) "collusive practices" means a scheme or arrangement between two or more Bidders, with or without the knowledge of the Procuring Entity, designed to establish bid prices at artificial, non-competitive levels.
 - (iv) "coercive practices" means harming or threatening to harm, directly or indirectly, persons, or their property to influence their participation in a procurement process, or affect the execution of a contract;
 - (v) "obstructive practice" is
 - (aa) deliberately destroying, falsifying, altering or concealing of evidence material to an administrative proceedings or investigation or making false statements to investigators in order to materially impede an

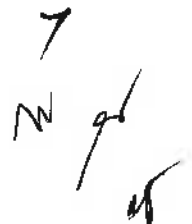

administrative proceedings or investigation of the Procuring Entity or any foreign government/foreign or international financing institution into allegations of a corrupt, fraudulent, coercive or collusive practice; and/or threatening, harassing or intimidating any party to prevent it from disclosing its knowledge of matters relevant to the administrative proceedings or investigation or from pursuing such proceedings or investigation; or

(bb) acts intended to materially impede the exercise of the inspection and audit rights of the Procuring Entity or any foreign government/foreign or international financing institution herein.

(b) will reject a proposal for award if it determines that the Bidder recommended for award has engaged in any of the practices mentioned in this Clause for purposes of competing for the contract.

2.2. Further the Funding Source, Borrower or Procuring Entity, as appropriate, will seek to impose the maximum civil, administrative and/or criminal penalties available under the applicable law on individuals and organizations deemed to be involved with any of the practices mentioned in GCC Clause 2.1(a).

3. Inspection and Audit by the Funding Source

The Supplier shall permit the Funding Source to inspect the Supplier's accounts and records relating to the performance of the Supplier and to have them audited by auditors appointed by the Funding Source, if so required by the Funding Source.

4. Governing Law and Language

4.1. This Contract shall be interpreted in accordance with the laws of the Republic of the Philippines.

4.2. This Contract has been executed in the English language, which shall be the binding and controlling language for all matters relating to the meaning or interpretation of this Contract. All correspondence and other documents pertaining to this Contract exchanged by the parties shall be written in English.

5. Notices

5.1. Any notice, request, or consent required or permitted to be given or made pursuant to this Contract shall be in writing. Any such notice, request, or consent shall be deemed to have been given or made when received by the concerned party, either in person or through an authorized representative of the Party to whom the communication is addressed, or when sent by registered mail, telex, telegram, or facsimile to such Party at the address specified in the



SCC, which shall be effective when delivered and duly received or on the notice's effective date, whichever is later.

- 5.2. A Party may change its address for notice hereunder by giving the other Party notice of such change pursuant to the provisions listed in the SCC for GCC Clause 5.1.

6. Scope of Contract

- 6.1. The GOODS and Related Services to be provided shall be as specified in Section VI. Schedule of Requirements.
- 6.2. This Contract shall include all such items, although not specifically mentioned, that can be reasonably inferred as being required for its completion as if such items were expressly mentioned herein. Any additional requirements for the completion of this Contract shall be provided in the SCC.

7. Subcontracting

- 7.1. Subcontracting of any portion of the Goods, if allowed in the **BDS**, does not relieve the Supplier of any liability or obligation under this Contract. The Supplier will be responsible for the acts, defaults, and negligence of any subcontractor, its agents, servants or workmen as fully as if these were the Supplier's own acts, defaults, or negligence, or those of its agents, servants or workmen.
- 7.2. Subcontractors disclosed and identified during the bidding may be changed during the implementation of this Contract, subject to compliance with the required qualifications and the approval of the Procuring Entity.

8. Procuring Entity's Responsibilities

- 8.1. Whenever the performance of the obligations in this Contract requires that the Supplier obtain permits, approvals, import, and other licenses from local public authorities, the Procuring Entity shall, if so needed by the Supplier, make its best effort to assist the Supplier in complying with such requirements in a timely and expeditious manner.
- 8.2. The Procuring Entity shall pay all costs involved in the performance of its responsibilities in accordance with GCC Clause 6.

9. Prices

- 9.1. For the given scope of work in this Contract as awarded, all bid prices are considered fixed prices, and therefore not subject to price escalation during contract implementation, except under extraordinary circumstances and upon prior approval of the GPPB in accordance with Section 61 of R.A. 9184 and its IRR or except as provided in this Clause.
- 9.2. Prices charged by the Supplier for Goods delivered and/or services performed under this Contract shall not vary from the prices quoted by the Supplier in its

7
9/10/20
98

bid, with the exception of any change in price resulting from a Change Order issued in accordance with GCC Clause 29.

10. Payment

- 10.1. Payments shall be made only upon a certification by the Head of the Procuring Entity to the effect that the Goods have been rendered or delivered in accordance with the terms of this Contract and have been duly inspected and accepted. Except with the prior approval of the President no payment shall be made for services not yet rendered or for supplies and materials not yet delivered under this Contract. Ten percent (10%) of the amount of each payment shall be retained by the Procuring Entity to cover the Supplier's warranty obligations under this Contract as described in GCC Clause 17.
- 10.2. The Supplier's request(s) for payment shall be made to the Procuring Entity in writing, accompanied by an invoice describing, as appropriate, the Goods delivered and/or Services performed, and by documents submitted pursuant to the SCC provision for GCC Clause 6.2, and upon fulfillment of other obligations stipulated in this Contract.
- 10.3. Pursuant to GCC Clause 10.2, payments shall be made promptly by the Procuring Entity, but in no case later than sixty (60) days after submission of an invoice or claim by the Supplier.
- 10.4. Unless otherwise provided in the SCC, the currency in which payment is made to the Supplier under this Contract shall be in Philippine Pesos.

11. Advance Payment and Terms of Payment

- 11.1. Advance payment shall be made only after prior approval of the President, and shall not exceed fifteen percent (15%) of the Contract amount, unless otherwise directed by the President or in cases allowed under Annex "D" of RA 9184.
- 11.2. For Goods supplied from abroad, the terms of payment shall be as follows:
 - (a) On Contract Signature: Fifteen Percent (15%) of the Contract Price shall be paid within sixty (60) days from signing of the Contract and upon submission of a claim and a bank guarantee for the equivalent amount valid until the Goods are delivered and in the form provided in Section VIII. Bidding Forms.
 - (b) On Delivery: Sixty-five percent (65%) of the Contract Price shall be paid to the Supplier within sixty (60) days after the date of receipt of the Goods and upon submission of the documents (i) through (vi) specified in the SCC provision on Delivery and Documents.
 - (c) On Acceptance: The remaining twenty percent (20%) of the Contract Price shall be paid to the Supplier within sixty (60) days after the date of submission of the acceptance and inspection certificate for the respective delivery issued by the Procuring Entity's authorized representative. In the event that no inspection or acceptance certificate

is issued by the Procuring Entity's authorized representative within forty five (45) days of the date shown on the delivery receipt the Supplier shall have the right to claim payment of the remaining twenty percent (20%) subject to the Procuring Entity's own verification of the reason(s) for the failure to issue documents (vii) and (viii) as described in the SCC provision on Delivery and Documents.

- 11.3. All progress payments shall first be charged against the advance payment until the latter has been fully exhausted.

12. Taxes and Duties

The Supplier, whether local or foreign, shall be entirely responsible for all the necessary taxes, stamp duties, license fees, and other such levies imposed for the completion of this Contract.

13. Performance Security

- 13.1. Within ten (10) calendar days from receipt of the Notice of Award from the Procuring Entity but in no case later than the signing of the contract by both parties, the successful Bidder shall furnish the performance security in any the forms prescribed in the ITB Clause 33.2.
- 13.2. The performance security posted in favor of the Procuring Entity shall be forfeited in the event it is established that the winning bidder is in default in any of its obligations under the contract.
- 13.3. The performance security shall remain valid until issuance by the Procuring Entity of the Certificate of Final Acceptance.
- 13.4. The performance security may be released by the Procuring Entity and returned to the Supplier after the issuance of the Certificate of Final Acceptance subject to the following conditions:
- (a) There are no pending claims against the Supplier or the surety company filed by the Procuring Entity;
 - (b) The Supplier has no pending claims for labor and materials filed against it; and
 - (c) Other terms specified in the SCC.
- 13.5. In case of a reduction of the contract value, the Procuring Entity shall allow a proportional reduction in the original performance security, provided that any such reduction is more than ten percent (10%) and that the aggregate of such reductions is not more than fifty percent (50%) of the original performance security.

14. Use of Contract Documents and Information

- 14.1. The Supplier shall not, except for purposes of performing the obligations in this Contract, without the Procuring Entity's prior written consent, disclose this Contract, or any provision thereof, or any specification, plan, drawing, pattern, sample, or information furnished by or on behalf of the Procuring Entity. Any such disclosure shall be made in confidence and shall extend only as far as may be necessary for purposes of such performance.
- 14.2. Any document, other than this Contract itself, enumerated in GCC Clause 14.1 shall remain the property of the Procuring Entity and shall be returned (all copies) to the Procuring Entity on completion of the Supplier's performance under this Contract if so required by the Procuring Entity.

15. Standards

The Goods provided under this Contract shall conform to the standards mentioned in the Section VII. Technical Specifications; and, when no applicable standard is mentioned, to the authoritative standards appropriate to the Goods' country of origin. Such standards shall be the latest issued by the institution concerned.

16. Inspection and Tests

- 16.1. The Procuring Entity or its representative shall have the right to inspect and/or to test the Goods to confirm their conformity to the Contract specifications at no extra cost to the Procuring Entity. The SCC and Section VII. Technical Specifications shall specify what inspections and/or tests the Procuring Entity requires and where they are to be conducted. The Procuring Entity shall notify the Supplier in writing, in a timely manner, of the identity of any representatives retained for these purposes.
- 16.2. If applicable, the inspections and tests may be conducted on the premises of the Supplier or its subcontractor(s), at point of delivery, and/or at the goods' final destination. If conducted on the premises of the Supplier or its subcontractor(s), all reasonable facilities and assistance, including access to drawings and production data, shall be furnished to the inspectors at no charge to the Procuring Entity. The Supplier shall provide the Procuring Entity with results of such inspections and tests.
- 16.3. The Procuring Entity or its designated representative shall be entitled to attend the tests and/or inspections referred to in this Clause provided that the Procuring Entity shall bear all of its own costs and expenses incurred in connection with such attendance including, but not limited to, all traveling and board and lodging expenses.
- 16.4. The Procuring Entity may reject any Goods or any part thereof that fail to pass any test and/or inspection or do not conform to the specifications. The Supplier shall either rectify or replace such rejected Goods or parts thereof or make alterations necessary to meet the specifications at no cost to the

Procuring Entity, and shall repeat the test and/or inspection, at no cost to the Procuring Entity, upon giving a notice pursuant to GCC Clause 5.

- 16.5. The Supplier agrees that neither the execution of a test and/or inspection of the Goods or any part thereof, nor the attendance by the Procuring Entity or its representative, shall release the Supplier from any warranties or other obligations under this Contract.

17. Warranty

- 17.1. The Supplier warrants that the Goods supplied under the Contract are new, unused, of the most recent or current models, and that they incorporate all recent improvements in design and materials, except when the technical specifications required by the Procuring Entity provides otherwise.
- 17.2. The Supplier further warrants that all Goods supplied under this Contract shall have no defect, arising from design, materials, or workmanship or from any act or omission of the Supplier that may develop under normal use of the supplied Goods in the conditions prevailing in the country of final destination.
- 17.3. In order to assure that manufacturing defects shall be corrected by the Supplier, a warranty shall be required from the Supplier for a minimum period specified in the SCC. The obligation for the warranty shall be covered by, at the Supplier's option, either retention money in an amount equivalent to at least ten percent (10%) of the final payment, or a special bank guarantee equivalent to at least ten percent (10%) of the Contract Price or other such amount if so specified in the SCC. The said amounts shall only be released after the lapse of the warranty period specified in the SCC; provided, however, that the Supplies delivered are free from patent and latent defects and all the conditions imposed under this Contract have been fully met.
- 17.4. The Procuring Entity shall promptly notify the Supplier in writing of any claims arising under this warranty. Upon receipt of such notice, the Supplier shall, within the period specified in the SCC and with all reasonable speed, repair or replace the defective Goods or parts thereof, without cost to the Procuring Entity.
- 17.5. If the Supplier, having been notified, fails to remedy the defect(s) within the period specified in GCC Clause 17.4, the Procuring Entity may proceed to take such remedial action as may be necessary, at the Supplier's risk and expense and without prejudice to any other rights which the Procuring Entity may have against the Supplier under the Contract and under the applicable law.

18. Delays in the Supplier's Performance

- 18.1. Delivery of the Goods and/or performance of Services shall be made by the Supplier in accordance with the time schedule prescribed by the Procuring Entity in Section VI. Schedule of Requirements.

- 18.2. If at any time during the performance of this Contract, the Supplier or its Subcontractor(s) should encounter conditions impeding timely delivery of the Goods and/or performance of Services, the Supplier shall promptly notify the Procuring Entity in writing of the fact of the delay, its likely duration and its cause(s). As soon as practicable after receipt of the Supplier's notice, and upon causes provided for under GCC Clause 22, the Procuring Entity shall evaluate the situation and may extend the Supplier's time for performance, in which case the extension shall be ratified by the parties by amendment of Contract.
- 18.3. Except as provided under GCC Clause 22, a delay by the Supplier in the performance of its obligations shall render the Supplier liable to the imposition of liquidated damages pursuant to GCC Clause 19, unless an extension of time is agreed upon pursuant to GCC Clause 29 without the application of liquidated damages.

19. Liquidated Damages

Subject to GCC Clauses 18 and 22, if the Supplier fails to satisfactorily deliver any or all of the Goods and/or to perform the Services within the period(s) specified in this Contract inclusive of duly granted time extensions if any, the Procuring Entity shall, without prejudice to its other remedies under this Contract and under the applicable law, deduct from the Contract Price, as liquidated damages, the applicable rate of one tenth (1/10) of one (1) percent of the cost of the unperformed portion for every day of delay until actual delivery or performance. The maximum deduction shall be ten percent (10%) of the amount of contract. Once the maximum is reached, the Procuring Entity shall rescind the Contract pursuant to GCC Clause 23, without prejudice to other courses of action and remedies open to it.

20. Settlement of Disputes

- 20.1. If any dispute or difference of any kind whatsoever shall arise between the Procuring Entity and the Supplier in connection with or arising out of this Contract, the parties shall make every effort to resolve amicably such dispute or difference by mutual consultation.
- 20.2. If after thirty (30) days, the parties have failed to resolve their dispute or difference by such mutual consultation, then either the Procuring Entity or the Supplier may give notice to the other party of its intention to commence arbitration, as hereinafter provided, as to the matter in dispute, and no arbitration in respect of this matter may be commenced unless such notice is given.
- 20.3. Any dispute or difference in respect of which a notice of intention to commence arbitration has been given in accordance with this Clause shall be settled by arbitration. Arbitration may be commenced prior to or after delivery of the Goods under this Contract.
- 20.4. In the case of a dispute between the Procuring Entity and the Supplier, the dispute shall be resolved in accordance with Republic Act 9285 ("R.A. 9285"), otherwise known as the "Alternative Dispute Resolution Act of 2004."

Handwritten signature and initials in the bottom right corner of the page.

- 20.5. Notwithstanding any reference to arbitration herein, the parties shall continue to perform their respective obligations under the Contract unless they otherwise agree; and the Procuring Entity shall pay the Supplier any monies due the Supplier.

21. Liability of the Supplier

- 21.1. The Supplier's liability under this Contract shall be as provided by the laws of the Republic of the Philippines, subject to additional provisions, if any, set forth in the SCC.
- 21.2. Except in cases of criminal negligence or willful misconduct, and in the case of infringement of patent rights, if applicable, the aggregate liability of the Supplier to the Procuring Entity shall not exceed the total Contract Price, provided that this limitation shall not apply to the cost of repairing or replacing defective equipment.

22. Force Majeure

- 22.1. The Supplier shall not be liable for forfeiture of its performance security, liquidated damages, or termination for default if and to the extent that the Supplier's delay in performance or other failure to perform its obligations under the Contract is the result of a *force majeure*.
- 22.2. For purposes of this Contract the terms "*force majeure*" and "fortuitous event" may be used interchangeably. In this regard, a fortuitous event or *force majeure* shall be interpreted to mean an event which the Contractor could not have foreseen, or which though foreseen, was inevitable. It shall not include ordinary unfavorable weather conditions; and any other cause the effects of which could have been avoided with the exercise of reasonable diligence by the Contractor. Such events may include, but not limited to, acts of the Procuring Entity in its sovereign capacity, wars or revolutions, fires, floods, epidemics, quarantine restrictions, and freight embargoes.
- 22.3. If a *force majeure* situation arises, the Supplier shall promptly notify the Procuring Entity in writing of such condition and the cause thereof. Unless otherwise directed by the Procuring Entity in writing, the Supplier shall continue to perform its obligations under the Contract as far as is reasonably practical, and shall seek all reasonable alternative means for performance not prevented by the *force majeure*.

23. Termination for Default

- 23.1. The Procuring Entity shall terminate this Contract for default when any of the following conditions attends its implementation:
- (a) Outside of *force majeure*, the Supplier fails to deliver or perform any or all of the Goods within the period(s) specified in the contract, or within any extension thereof granted by the Procuring Entity pursuant to a request made by the Supplier prior to the delay, and such failure amounts to at least ten percent (10%) of the contract price;

- (b) As a result of *force majeure*, the Supplier is unable to deliver or perform any or all of the Goods, amounting to at least ten percent (10%) of the contract price, for a period of not less than sixty (60) calendar days after receipt of the notice from the Procuring Entity stating that the circumstance of force majeure is deemed to have ceased; or
 - (c) The Supplier fails to perform any other obligation under the Contract.
- 23.2. In the event the Procuring Entity terminates this Contract in whole or in part, for any of the reasons provided under GCC Clauses 23 to 26, the Procuring Entity may procure, upon such terms and in such manner as it deems appropriate, Goods or Services similar to those undelivered, and the Supplier shall be liable to the Procuring Entity for any excess costs for such similar Goods or Services. However, the Supplier shall continue performance of this Contract to the extent not terminated.
- 23.3. In case the delay in the delivery of the Goods and/or performance of the Services exceeds a time duration equivalent to ten percent (10%) of the specified contract time plus any time extension duly granted to the Supplier, the Procuring Entity may terminate this Contract, forfeit the Supplier's performance security and award the same to a qualified Supplier.

24. Termination for Insolvency

The Procuring Entity shall terminate this Contract if the Supplier is declared bankrupt or insolvent as determined with finality by a court of competent jurisdiction. In this event, termination will be without compensation to the Supplier, provided that such termination will not prejudice or affect any right of action or remedy which has accrued or will accrue thereafter to the Procuring Entity and/or the Supplier.

25. Termination for Convenience

- 25.1. The Procuring Entity may terminate this Contract, in whole or in part, at any time for its convenience. The Head of the Procuring Entity may terminate a contract for the convenience of the Government if he has determined the existence of conditions that make Project Implementation economically, financially or technically impractical and/or unnecessary, such as, but not limited to, fortuitous event(s) or changes in law and national government policies.
- 25.2. The Goods that have been delivered and/or performed or are ready for delivery or performance within thirty (30) calendar days after the Supplier's receipt of Notice to Terminate shall be accepted by the Procuring Entity at the contract terms and prices. For Goods not yet performed and/or ready for delivery, the Procuring Entity may elect:
- (a) to have any portion delivered and/or performed and paid at the contract terms and prices; and/or

- (b) to cancel the remainder and pay to the Supplier an agreed amount for partially completed and/or performed goods and for materials and parts previously procured by the Supplier.

25.3. If the Supplier suffers loss in its initial performance of the terminated contract, such as purchase of raw materials for goods specially manufactured for the Procuring Entity which cannot be sold in open market, it shall be allowed to recover partially from this Contract, on a *quantum meruit* basis. Before recovery may be made, the fact of loss must be established under oath by the Supplier to the satisfaction of the Procuring Entity before recovery may be made.

26. Termination for Unlawful Acts

26.1. The Procuring Entity may terminate this Contract in case it is determined *prima facie* that the Supplier has engaged, before or during the implementation of this Contract, in unlawful deeds and behaviors relative to contract acquisition and implementation. Unlawful acts include, but are not limited to, the following:

- (a) Corrupt, fraudulent, and coercive practices as defined in ITB Clause 3.1(a);
- (b) Drawing up or using forged documents;
- (c) Using adulterated materials, means or methods, or engaging in production contrary to rules of science or the trade; and
- (d) Any other act analogous to the foregoing.

27. Procedures for Termination of Contracts

27.1. The following provisions shall govern the procedures for termination of this Contract:

- (a) Upon receipt of a written report of acts or causes which may constitute ground(s) for termination as aforementioned, or upon its own initiative, the Implementing Unit shall, within a period of seven (7) calendar days, verify the existence of such ground(s) and cause the execution of a Verified Report, with all relevant evidence attached;
- (b) Upon recommendation by the Implementing Unit, the Head of the Procuring Entity shall terminate this Contract only by a written notice to the Supplier conveying the termination of this Contract. The notice shall state:
 - (i) that this Contract is being terminated for any of the ground(s) afore-mentioned, and a statement of the acts that constitute the ground(s) constituting the same;
 - (ii) the extent of termination, whether in whole or in part;

- (iii) an instruction to the Supplier to show cause as to why this Contract should not be terminated; and
 - (iv) special instructions of the Procuring Entity, if any.
- (c) The Notice to Terminate shall be accompanied by a copy of the Verified Report;
 - (d) Within a period of seven (7) calendar days from receipt of the Notice of Termination, the Supplier shall submit to the Head of the Procuring Entity a verified position paper stating why this Contract should not be terminated. If the Supplier fails to show cause after the lapse of the seven (7) day period, either by inaction or by default, the Head of the Procuring Entity shall issue an order terminating this Contract;
 - (e) The Procuring Entity may, at any time before receipt of the Supplier's verified position paper described in item (d) above withdraw the Notice to Terminate if it is determined that certain items or works subject of the notice had been completed, delivered, or performed before the Supplier's receipt of the notice;
 - (f) Within a non-extendible period of ten (10) calendar days from receipt of the verified position paper, the Head of the Procuring Entity shall decide whether or not to terminate this Contract. It shall serve a written notice to the Supplier of its decision and, unless otherwise provided, this Contract is deemed terminated from receipt of the Supplier of the notice of decision. The termination shall only be based on the ground(s) stated in the Notice to Terminate;
 - (g) The Head of the Procuring Entity may create a Contract Termination Review Committee (CTRC) to assist him in the discharge of this function. All decisions recommended by the CTRC shall be subject to the approval of the Head of the Procuring Entity; and
 - (h) The Supplier must serve a written notice to the Procuring Entity of its intention to terminate the contract at least thirty (30) calendar days before its intended termination. The Contract is deemed terminated if it is not resumed in thirty (30) calendar days after the receipt of such notice by the Procuring Entity.

28. Assignment of Rights

The Supplier shall not assign his rights or obligations under this Contract, in whole or in part, except with the Procuring Entity's prior written consent.

29. Contract Amendment

Subject to applicable laws, no variation in or modification of the terms of this Contract shall be made except by written amendment signed by the parties.

30. Application

These General Conditions shall apply to the extent that they are not superseded by provisions of other parts of this Contract.

WJ
as

Section V. Special Conditions of Contract

Special Conditions of Contract

| GCC Clause | |
|------------|--|
| 1.1(g) | The Procuring Entity is Technical Education and Skills Development Authority (TESDA) . |
| 1.1(i) | The Supplier is: |
| 1.1(j) | The Funding Source is the Government of the Philippines (GOP) through the TESDA trust fund account in the amount of Php37,185,144.048 |
| 1.1(k) | The Project Sites are ten (10) provincial offices of TESDA, namely Apayao, Masbate, Eastern Samar, Northern Samar, Zamboanga del Norte, Camiguin, North Cotabato, Sarangani, Lanao del Sur and Maguindanao. |
| 5.1 | <p>The Procuring Entity's address for Notices is:</p> <p>SEC. IRENE M. ISAAC Director General Technical Education and Skills Development Authority East Service Road South Luzon Expressway Taguig City, Metro Manila Philippines</p> <p>Tel/Fax No. 893-8296</p> <p>The Supplier's address for Notices is:</p> <p>_____</p> <p>_____</p> <p>_____</p> |
| 6.2 | <p>Delivery and Documents --</p> <p>For purposes of the Contract, "EXW," "FOB," "FCA," "CIF," "CIP," "DDP" and other trade terms used to describe the obligations of the parties shall have the meanings assigned to them by the current edition of INCOTERMS published by the International Chamber of Commerce, Paris. The Delivery terms of this Contract shall be as follows:</p> <p><i>For Goods Supplied from Abroad, state "The delivery terms applicable to the Contract are DDP delivered to various regional offices of TESDA. In accordance with INCOTERMS."</i></p> |

1
 go N
 at

For Goods Supplied from Within the Philippines, state "The delivery terms applicable to this Contract are delivered to various regional offices of TESDA. Risk and title will pass from the Supplier to the Procuring Entity upon receipt and final acceptance of the Goods at their final destination."

Delivery of the Goods shall be made by the Supplier in accordance with the terms specified in Section VI. Schedule of Requirements. The details of shipping and/or other documents to be furnished by the Supplier are as follows:

For Goods supplied from within the Philippines:

Upon delivery of the Goods to the Project Site, the Supplier shall notify the Procuring Entity and present the following documents to the Procuring Entity:

- (i) Original and four copies of the Supplier's invoice showing Goods' description, quantity, unit price, and total amount;
- (ii) Original and four copies delivery receipt/note, railway receipt, or truck receipt;
- (iii) Original Supplier's factory inspection report;
- (iv) Original and four copies of the Manufacturer's and/or Supplier's warranty certificate;
- (v) Original and four copies of the certificate of origin (for imported Goods);
- (vi) Delivery receipt detailing number and description of items received signed by the authorized receiving personnel;
- (vii) Certificate of Acceptance/Inspection Report signed by the Procuring Entity's representative at the Project Site; and
- (viii) Four copies of the Invoice Receipt for Property signed by the Procuring Entity's representative at the Project Site.

For Goods supplied from abroad:

Upon shipment, the Supplier shall notify the Procuring Entity and the insurance company by cable the full details of the shipment, including Contract Number, description of the Goods, quantity, vessel, bill of lading number and date, port of loading, date of shipment, port of discharge etc. Upon delivery to the Project Site, the Supplier shall notify the Procuring Entity and present the following documents as applicable with the documentary requirements of any letter of credit issued taking

precedence:

- (i) Original and four copies of the Supplier's invoice showing Goods' description, quantity, unit price, and total amount;
- (ii) Original and four copies of the negotiable, clean shipped on board bill of lading marked "freight pre-paid" and five copies of the non-negotiable bill of lading ;
- (iii) Original Supplier's factory inspection report;
- (iv) Original and four copies of the Manufacturer's and/or Supplier's warranty certificate;
- (v) Original and four copies of the certificate of origin (for imported Goods);
- (vi) Delivery receipt detailing number and description of items received signed by the Procuring Entity's representative at the Project Site;
- (vii) Certificate of Acceptance/Inspection Report signed by the Procuring Entity's representative at the Project Site; and
- (viii) Four copies of the Invoice Receipt for Property signed by the Procuring Entity's representative at the Project Site.

For purposes of this Clause the Procuring Entity's Representative at the Project Site is the Regional Director.

Incidental Services –

The Supplier is required to provide all of the following services, including additional services, if any, specified in Section VI. Schedule of Requirements:

- (a) performance or supervision of on-site assembly and/or start-up of the supplied Goods;
- (b) furnishing of tools required for assembly and/or maintenance of the supplied Goods;
- (c) furnishing of a detailed operations and maintenance manual for each appropriate unit of the supplied Goods;
- (d) performance or supervision or maintenance and/or repair of the supplied Goods, for a period of time agreed by the parties, provided that this service shall not relieve the Supplier of any warranty obligations under this Contract; and
- (e) training of the Procuring Entity's personnel, at the Supplier's plant and/or on-site, in assembly, start-up, operation, maintenance, and/or repair of the supplied

Goods.

The Contract price for the Goods shall include the prices charged by the Supplier for incidental services and shall not exceed the prevailing rates charged to other parties by the Supplier for similar services.

Spare Parts –

The Supplier is required to provide all of the following materials, notifications, and information pertaining to spare parts manufactured or distributed by the Supplier:

- (a) such spare parts as the Procuring Entity may elect to purchase from the Supplier, provided that this election shall not relieve the Supplier of any warranty obligations under this Contract; and
- (b) in the event of termination of production of the spare parts:
 - i. advance notification to the Procuring Entity of the pending termination, in sufficient time to permit the Procuring Entity to procure needed requirements; and
 - ii. following such termination, furnishing at no cost to the Procuring Entity, the blueprints, drawings, and specifications of the spare parts, if requested.

The spare parts required are listed in Section VI. Schedule of Requirements and the cost thereof are included in the Contract Price

Packaging –

The Supplier shall provide such packaging of the Goods as is required to prevent their damage or deterioration during transit to their final destination, as indicated in this Contract. The packaging shall be sufficient to withstand, without limitation, rough handling during transit and exposure to extreme temperatures, salt and precipitation during transit, and open storage. Packaging case size and weights shall take into consideration, where appropriate, the remoteness of the GOODS' final destination and the absence of heavy handling facilities at all points in transit.

The packaging, marking, and documentation within and outside the packages shall comply strictly with such special requirements as shall be expressly provided for in the Contract, including additional requirements, if any, specified below, and

in any subsequent instructions ordered by the Procuring Entity.

The outer packaging must be clearly marked on at least four (4) sides as follows:

Name of the Procuring Entity

Name of the Supplier

Contract Description

Final Destination

Gross weight

Any special lifting instructions

Any special handling instructions

Any relevant HAZCHEM classifications

A packaging list identifying the contents and quantities of the package is to be placed on an accessible point of the outer packaging if practical. If not practical the packaging list is to be placed inside the outer packaging but outside the secondary packaging.

Insurance –

The Goods supplied under this Contract shall be fully insured by the Supplier in a freely convertible currency against loss or damage incidental to manufacture or acquisition, transportation, storage, and delivery. The Goods remain at the risk and title of the Supplier until their final acceptance by the Procuring Entity.

Transportation –

Where the Supplier is required under Contract to deliver the Goods CIF, CIP or DDP, transport of the Goods to the port of destination or such other named place of destination in the Philippines, as shall be specified in this Contract, shall be arranged and paid for by the Supplier, and the cost thereof shall be included in the Contract Price.

Where the Supplier is required under this Contract to transport the Goods to a specified place of destination within the Philippines, defined as the Project Site, transport to such place of destination in the Philippines, including insurance and storage, as shall be specified in this Contract, shall be arranged by the Supplier, and related costs shall be included in the Contract Price.

Where the Supplier is required under Contract to deliver the Goods CIF, CIP or DDP, Goods are to be transported on

1
9/12
af

| | |
|---------|--|
| | <p>carriers of Philippine registry. In the event that no carrier of Philippine registry is available, Goods may be shipped by a carrier which is not of Philippine registry provided that the Supplier obtains and presents to the Procuring Entity certification to this effect from the nearest Philippine consulate to the port of dispatch. In the event that carriers of Philippine registry are available but their schedule delays the Supplier in its performance of this Contract the period from when the Goods were first ready for shipment and the actual date of shipment the period of delay will be considered <i>force majeure</i> in accordance with GCC Clause 22.</p> <p>The Procuring Entity accepts no liability for the damage of Goods during transit other than those prescribed by INCOTERMS for DDP Deliveries. In the case of Goods supplied from within the Philippines or supplied by domestic Suppliers risk and title will not be deemed to have passed to the Procuring Entity until their receipt and final acceptance at the final destination.</p> <p>Patent Rights –</p> <p>The Supplier shall indemnify the Procuring Entity against all third-party claims of infringement of patent, trademark, or industrial design rights arising from use of the Goods or any part thereof.</p> |
| 9 | For the given scope of work in this Contract as awarded, all bid prices are considered fixed prices, and therefore not subject to price escalation during contract implementation, except under extraordinary circumstances and upon prior approval of the GPPB in accordance with Section 61 of R.A. 9184 and its IRR-A. |
| 10.4 | Not applicable. |
| 13.4(c) | No further instructions. |
| 16.1 | The inspections and tests that will be conducted are: <i>[Insert the applicable inspections and tests, if none, state "None"]</i> . |
| 17.3 | <p><i>If the Goods pertain to Expendable Supplies:</i> Three (3) months after acceptance by the Procuring Entity of the delivered Goods or after the Goods are consumed, whichever is earlier.</p> <p><i>If the Goods pertain to Non-expendable Supplies:</i> One (1) year after acceptance by the Procuring Entity of the delivered Goods.</p> |
| 17.4 | The period for correction of defects in the warranty period is <i>[insert number of days]</i> . |
| 19 | The applicable rate is one tenth (1/10) of one (1) percent of the cost of the unperformed portion for every day of delay until |

T
M
at

| | |
|------|---|
| | <p>actual delivery or performance.</p> <p>The maximum deduction shall be ten percent (10%) of the amount of contract. Once the maximum is reached, the Procuring Entity shall rescind the Contract pursuant to GCC Clause 23, without prejudice to other courses of action and remedies open to it</p> |
| 20.4 | <p>In the case of a dispute between the Procuring Entity and the Supplier, the dispute shall be resolved in accordance with Republic Act 9285 ("R.A. 9285"), otherwise known as the "Alternative Dispute Resolution Act of 2004."</p> |
| 21.1 | <p>No additional provision.</p> |

Section VI. Schedule of Requirements

A. List of Goods and Related Services

The goods and related services refer to supply, delivery, installation, testing and training of end-user's representatives on the use of training tools and equipment. **Only bids for all the items in each lot shall be accepted. The bidding shall be done by lot. There are eighteen (18) lots. All bidders must bid for all items in a lot. However, evaluation and award of contract will be undertaken depending on whatever is most advantageous to the government in terms of technical specifications and costs.**

| Lot No. | QUALIFICATIONS |
|---|---|
| CMU boxes | |
| 1. | Common Box for Multimedia Equipment & Accessories and Mock-up |
| 2. | Appliance Repair NC II with Toolbox |
| 3. | Bread and Pastry NC II |
| 4. | Cookery NC II with Plastic Box |
| 5. | Electrical Installation and Maintenance NC II with Toolbox |
| 6. | Food Processing NC II with Plastic Box |
| 7. | Plumbing NC II |
| 8. | Small Engine Repair (Motorcycle/Small Engine Servicing NC II) with Toolbox |
| Tools and Equipment | |
| 9. | Appliance Repair NC II Tools and Equipment (for training purposes) |
| 10. | Bread and Pastry NC II Tools and Equipment (for training purposes) |
| 11. | Cookery NC II Tools and Equipment (for training purposes) |
| 12. | Electrical Installation and Maintenance NC II Tools and Equipment (for training purposes) |
| 13. | Food Processing NC II Tools and Equipment (for training purposes) |
| 14. | Plumbing NC II Tools and Equipment (for training purposes) |
| 15. | Small Engine Repair (Motorcycle/Small Engine Servicing NC II) Tools and Equipment (for training purposes) |
| Mock-ups for Electrical Installation and Maintenance, Plumbing and Small Engine Repair | |
| 16. | Electrical Installation and Maintenance NC II Mock-up |
| 17. | Plumbing NC II Mock-up |
| 18. | Small Engine Repair (Motorcycle/Small Engine Servicing NC II) Tools and Equipment Mock-up |

B. Delivery and Completion Schedule

The delivery period shall start from the date of the Notice to Proceed. No partial shipment shall be allowed. **Completion of the contract shall be made not later than ninety (90) calendar days from the date of the receipt by the winning bidder of the Notice to Proceed.**

Section VII. Technical Specifications

| Item | Specification | Statement of Compliance |
|------|--|-------------------------|
| | See attached Technical specifications | |

g/n
af

COMPARATIVE TECHNICAL SPECIFICATION

| TESDA'S SPECIFICATIONS | | BIDDER'S SPECIFICATIONS | |
|------------------------|--|--------------------------------------|---------------------------------|
| No. | Item | Specifications | Item/Brand/Model Specifications |
| Lot 1 | Common Box for Multimedia Equipment & Accessories and Mock-up MTL Box No. 1 | Please refer to the attached drawing | |

Name of Bidder: _____

Name and Signature of Authorized Representative: _____
 Position/Designation: _____
 Date: _____

✓

of

2

at

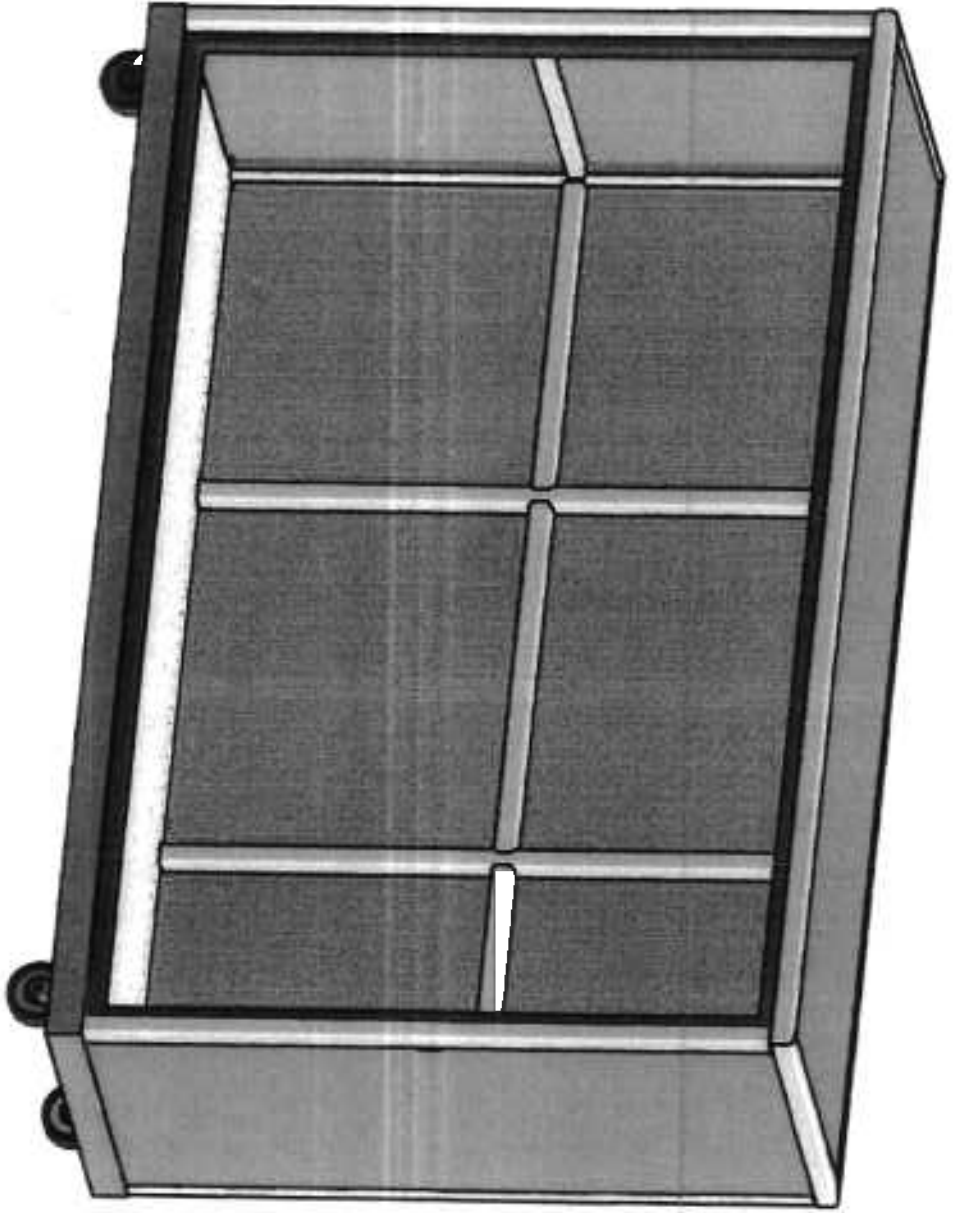

**MTL BOX NO. 1
(COMMON BOX)
QUANTITY:**

(The door is not shown in the drawing)

1

2

M



**TECHNICAL
EDUCATION AND
SKILLS
DEVELOPMENT
AUTHORITY**

**PROJECT TITLE
MOBILE TRAINING
LABORATORY**

Scale: 1:10

1 /

| MTL BOX 1 FRAME | | | |
|-----------------|------------------------------------|------------|------|
| NO. | MATERIAL | LENGTH, mm | Qty. |
| 1 | 2" x 2" x 3/16" angle bar | 1,600.00 | 2 |
| 2 | 2" x 2" x 3/16" angle bar | 500.00 | 2 |
| 3 | 1 1/4" x 1 1/4" x 2 mm square tube | 493.65 | 2 |
| 4 | 1 1/4" x 1 1/4" x 2 mm square tube | 968.25 | 6 |
| 5 | 1 1/4" x 1 1/4" x 2 mm square tube | 1,600.00 | 2 |
| 6 | 1 1/4" x 1 1/4" x 2 mm square tube | 500.00 | 2 |
| 7 | 1 1/4" x 1 1/4" x 2 mm square tube | 436.50 | 2 |
| 8 | 1 1/4" x 1 1/4" x 2 mm square tube | 1,473.00 | 1 |
| 9 | 1" x 1" x 1.5 mm square tube | 436.50 | 2 |
| TOTAL | | | 21 |

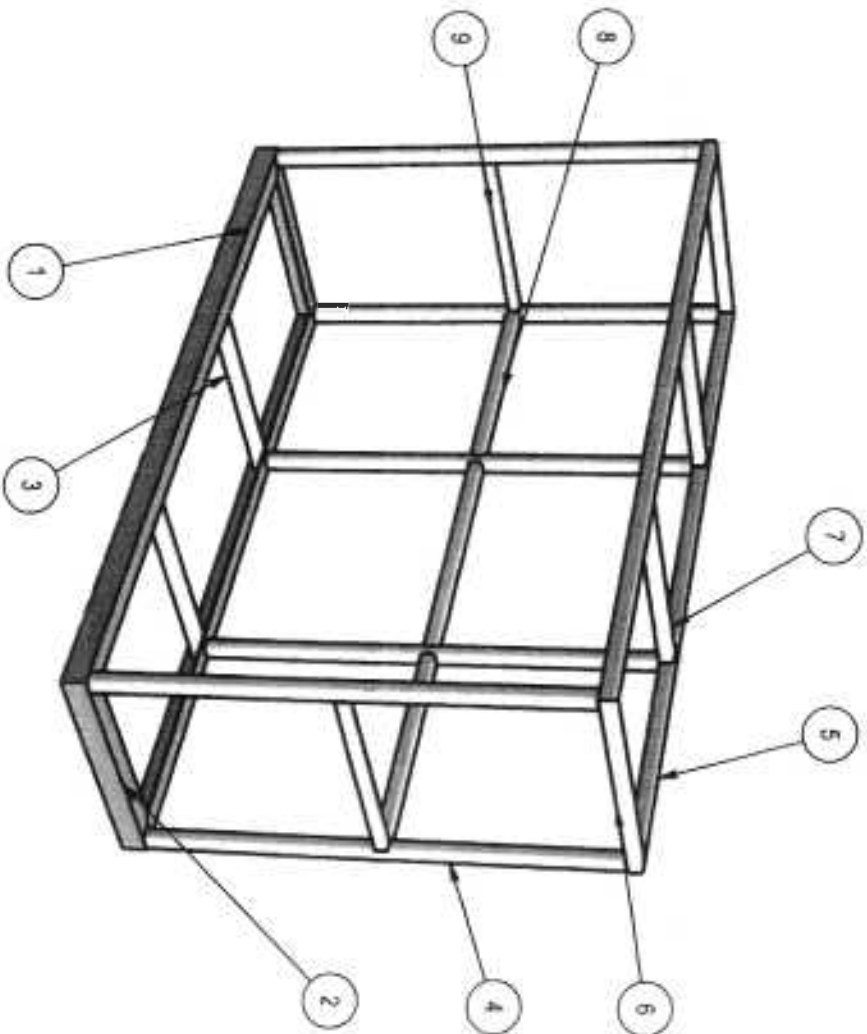

**MTL BOX NO. 1 FRAME
(COMMON BOX)**
(The door is not shown in the drawing)



TECHNICAL
EDUCATION AND
SKILLS
DEVELOPMENT
AUTHORITY

PROJECT TITLE
**MOBILE TRAINING
LABORATORY**

DRAWN BY JPA

Scale 1:15

Drawn No.
17

1 8 N

MTL BOX NO. 1

- ⊕ All materials must be painted with anti-corrosive primer
- ⊕ □ tube and ◁ bar are coated with light gray epoxy finish paint

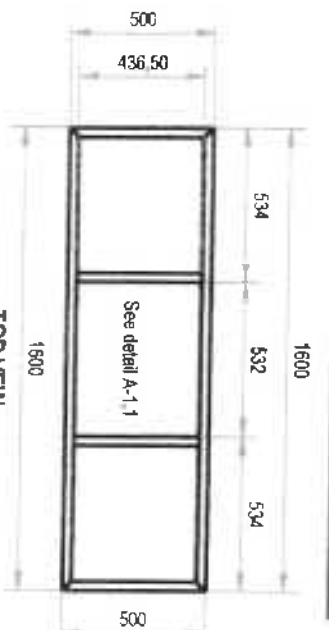

TOP VIEW

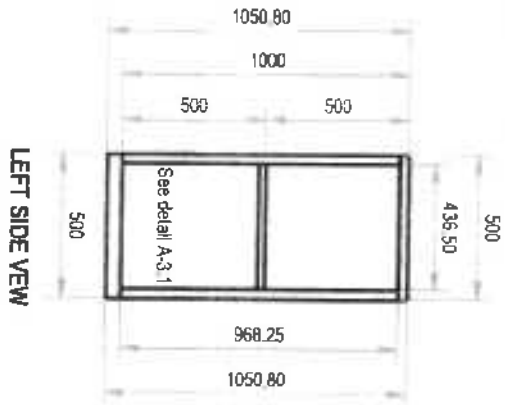

LEFT SIDE VIEW

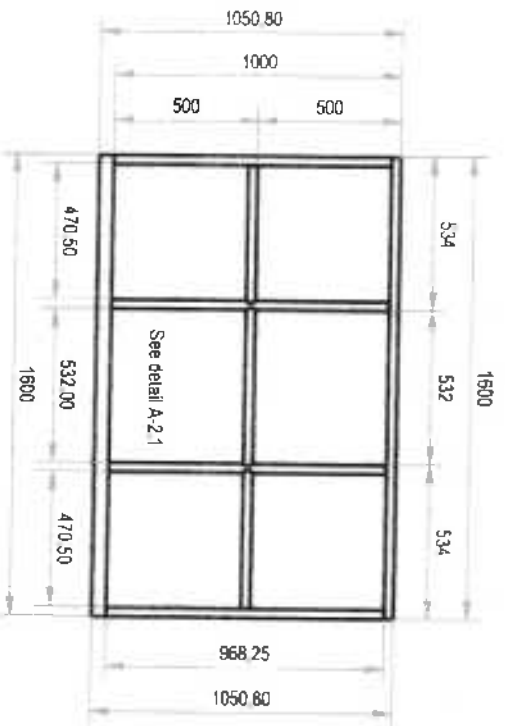

FRONT VIEW

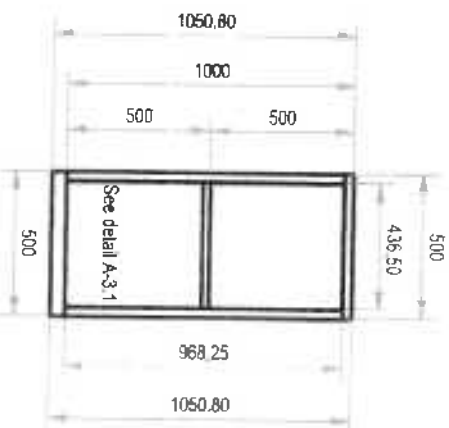

RIGHT SIDE VIEW

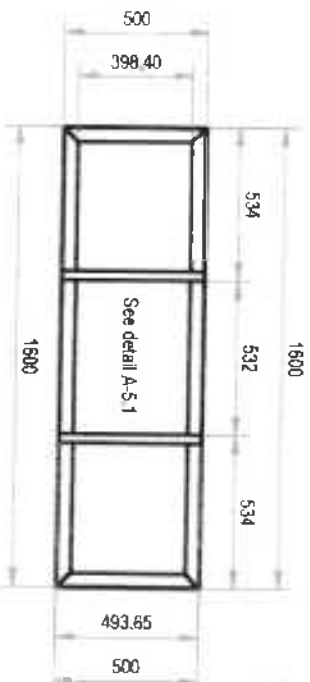

BOTTOM VIEW

**MTL BOX NO. 1 FRAME
(COMMON BOX)**
(The door is not shown in the drawing)



TECHNICAL
EDUCATION AND
SKILLS
DEVELOPMENT
AUTHORITY

PROJECT TITLE
**MOBILE TRAINING
LABORATORY**

DATE: 01/25/2017

Scale: 1:25

BY: [Signature]

DETAIL A-1.1:

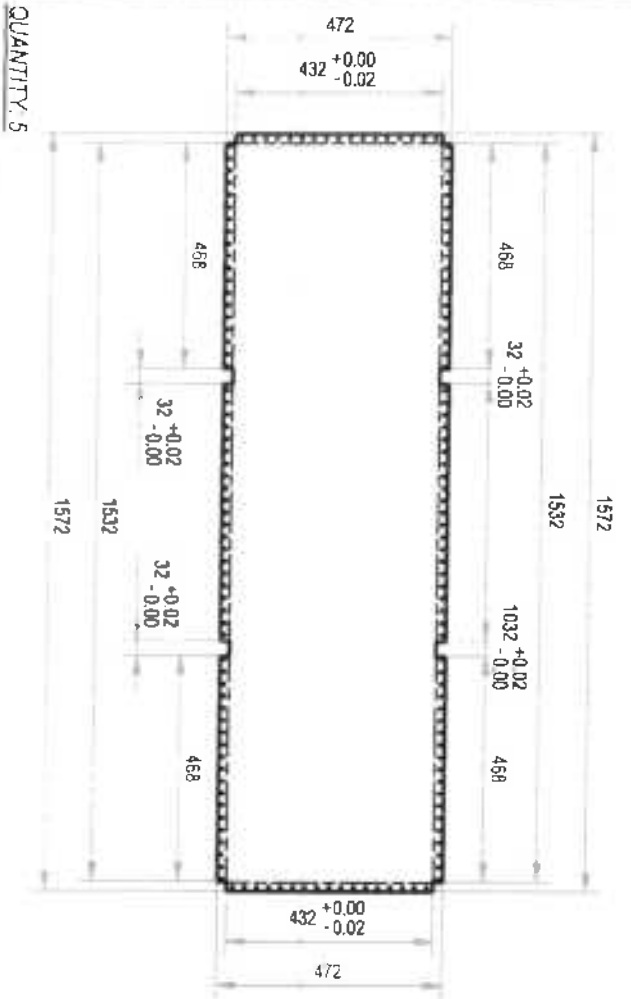

QUANTITY: 5

DETAIL A-1.3:

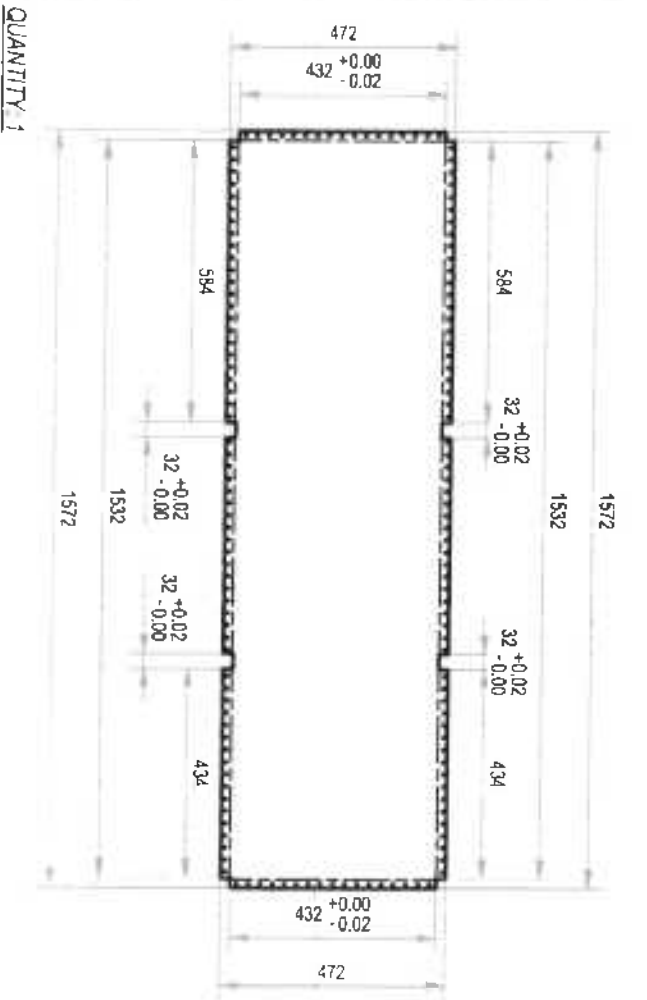

QUANTITY: 1

DETAIL A-1.2:

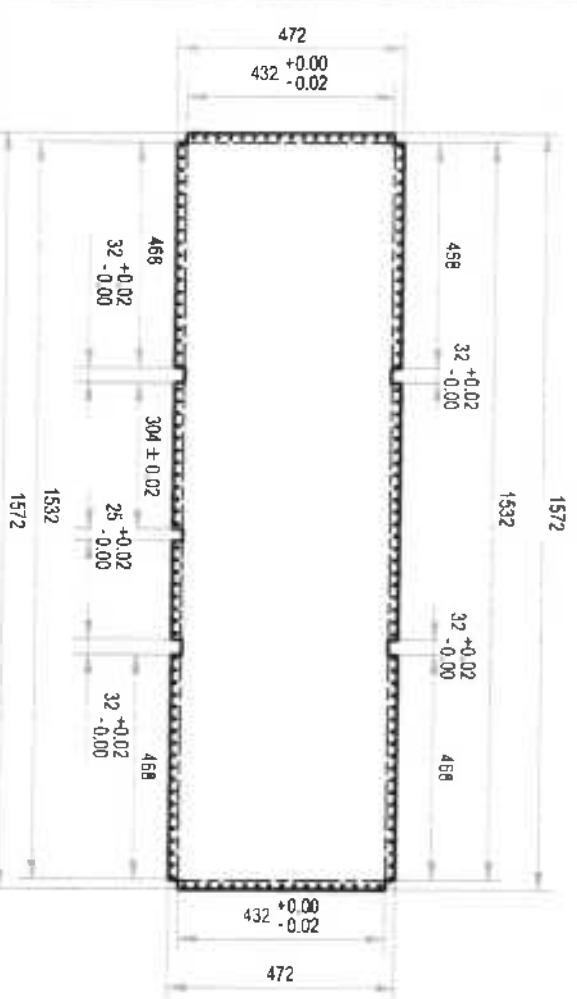

QUANTITY: 2

DETAIL A-1.4:



QUANTITY: 2

FLAT PATTERN: GALVANIZED SHEET GAUGE #18, PAINTED

Use 3/16" blind rivet spaced @ 1" O.C.



TECHNICAL EDUCATION AND SKILLS DEVELOPMENT AUTHORITY

PROJECT TITLE
MOBILE TRAINING LABORATORY

DRAWN BY: JPS

Scale: 1:1.5

Sheet No: 1 /

DETAIL A-2.1:

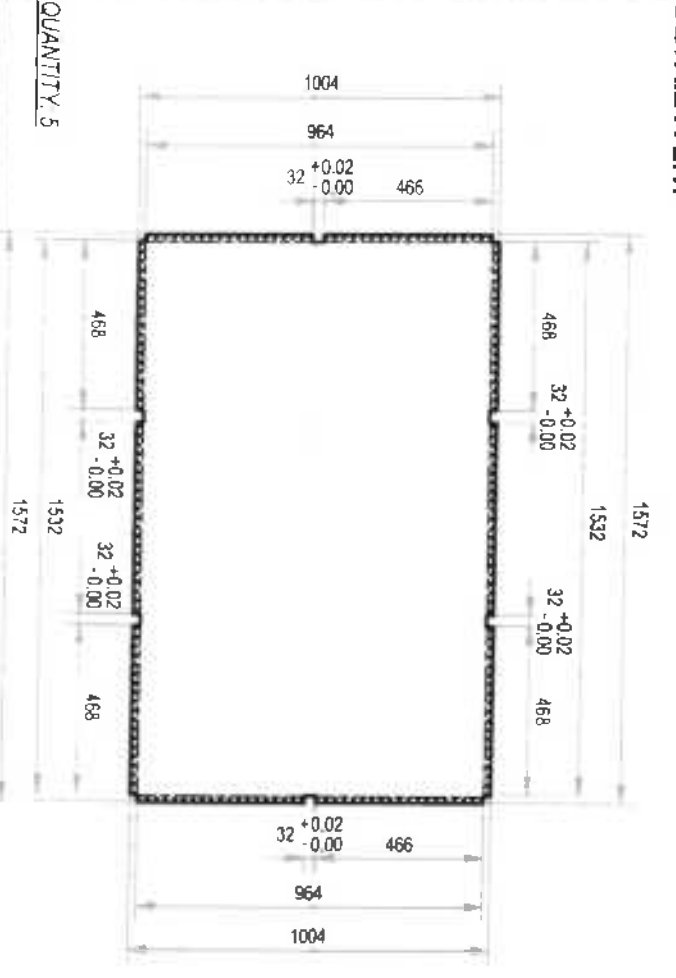

QUANTITY: 5

DETAIL A-2.3:

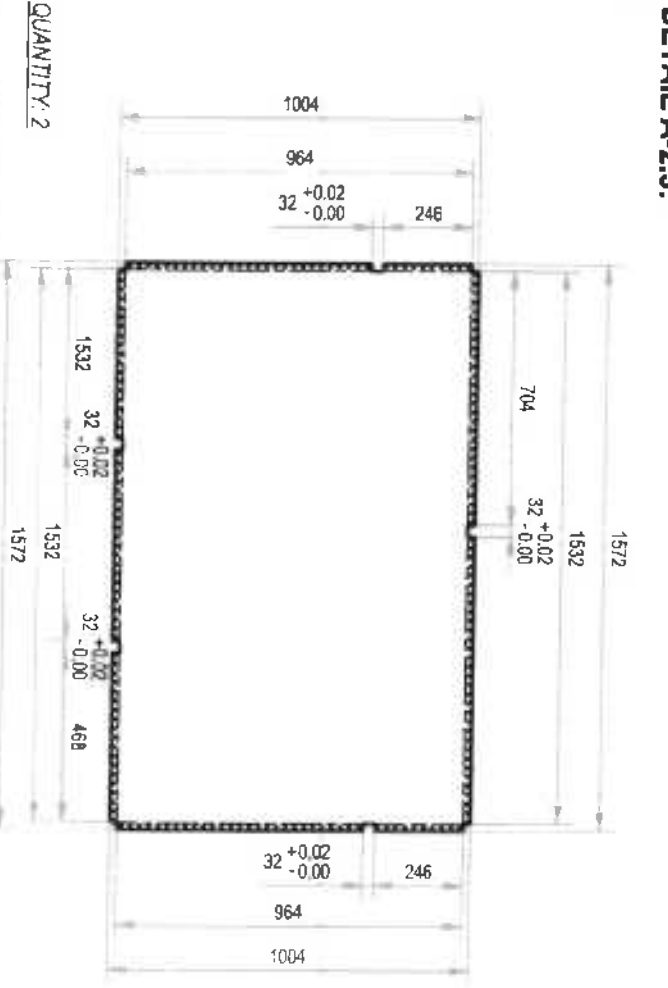

QUANTITY: 2

DETAIL A-2.2:

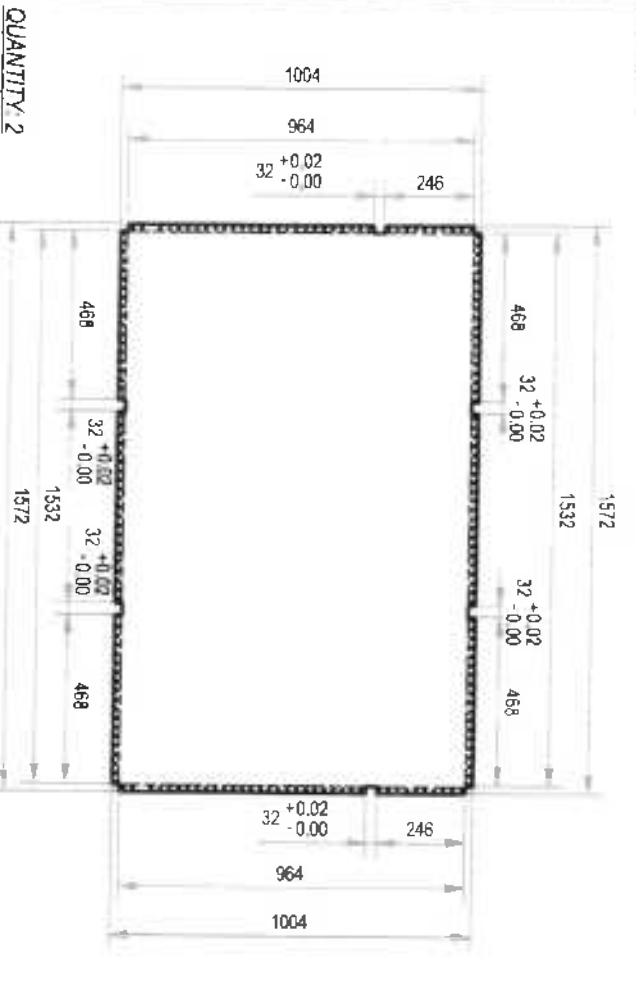

QUANTITY: 2

DETAIL A-2.4:

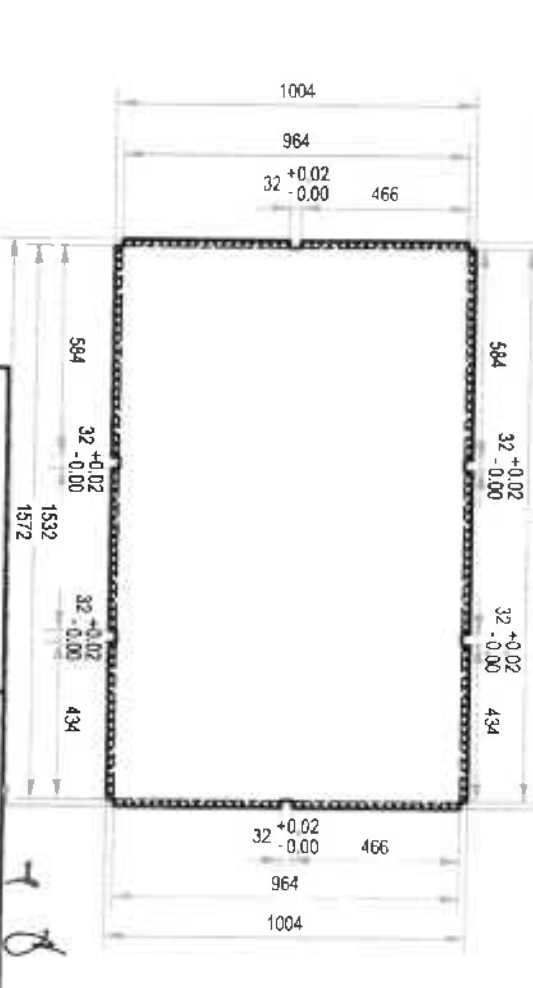

QUANTITY: 1

FLAT PATTERN: GALVANIZED SHEET GAUGE #18, PAINTED

Use 3/8" blind rivet spaced @ 1" O.C.



TECHNICAL EDUCATION AND SKILLS DEVELOPMENT AUTHORITY

PROJECT TITLE
MOBILE TRAINING LABORATORY

DRAWN BY: JSA
SCALE: 1:20

DETAIL A-3.1:

QUANTITY: 5

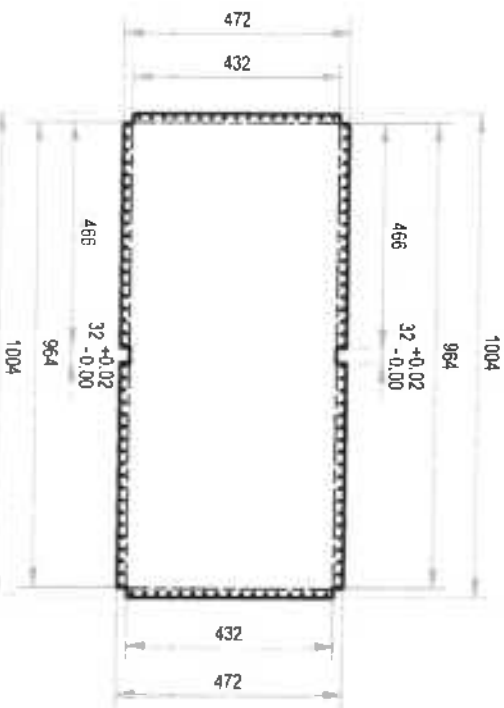

DETAIL A-3.3:

QUANTITY: 1

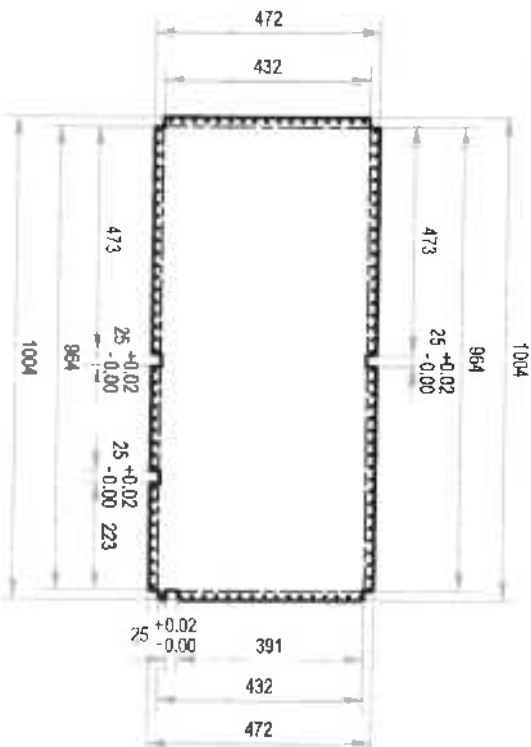

DETAIL A-3.2:

QUANTITY: 4

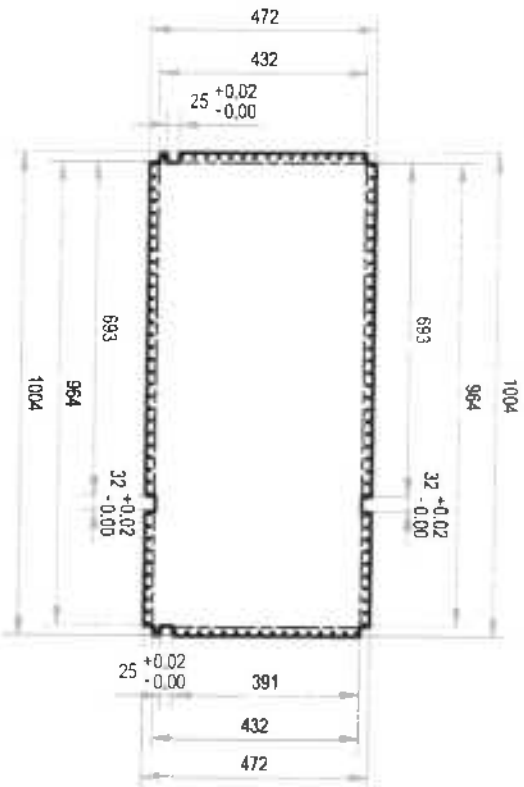

DETAIL A-3.4:

QUANTITY: 2

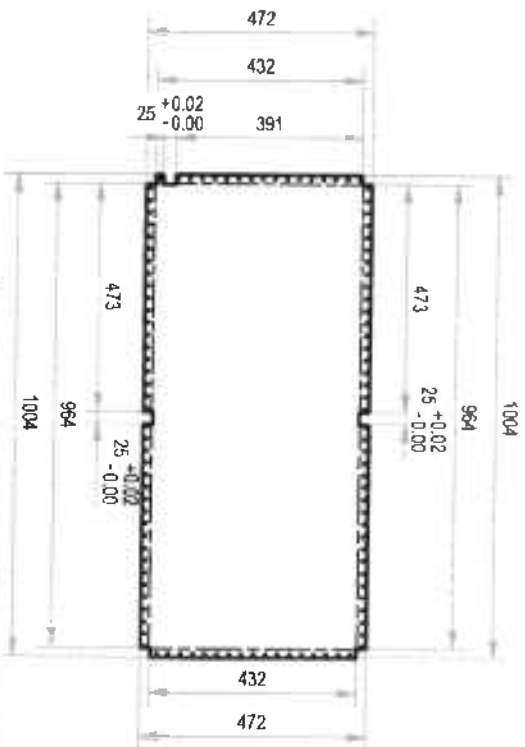

FLAT PATTERN, GALVANIZED SHEET GAUGE #18, PAINTED

Use 3/16" blind rivet spaced @ 1" O C



TECHNICAL EDUCATION AND SKILLS DEVELOPMENT AUTHORITY

PROJECT TITLE
MOBILE TRAINING LABORATORY

DRAWN BY: JSA
SCALE: 1:15
SHEET NO: 1/1

78

of

DETAIL A-5.1:

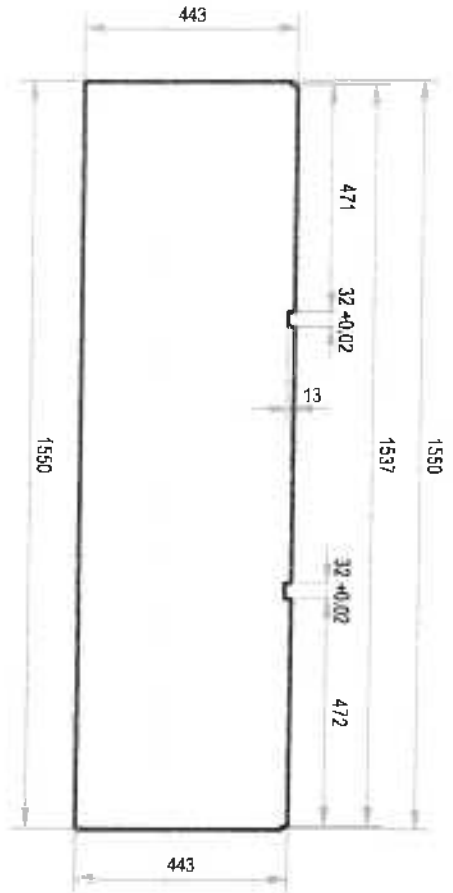

QUANTITY: 1

DETAIL A-5.3:

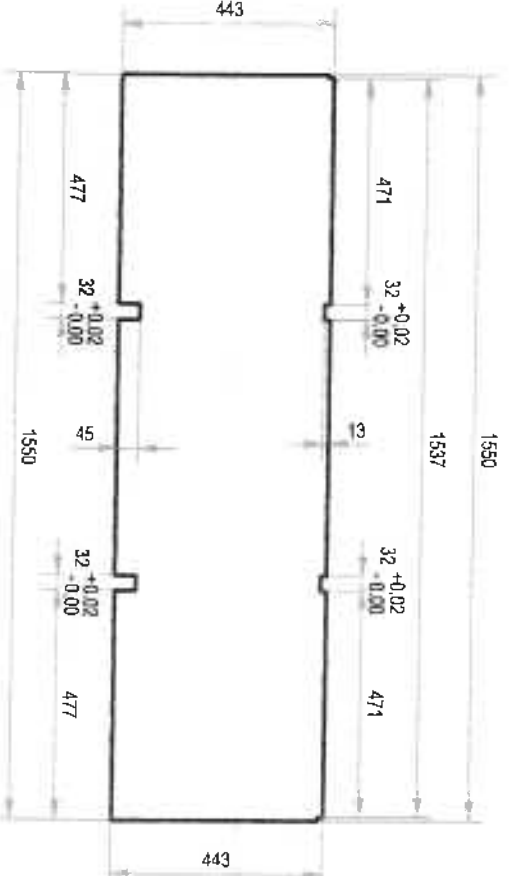

QUANTITY: 2

DETAIL A-5.2:

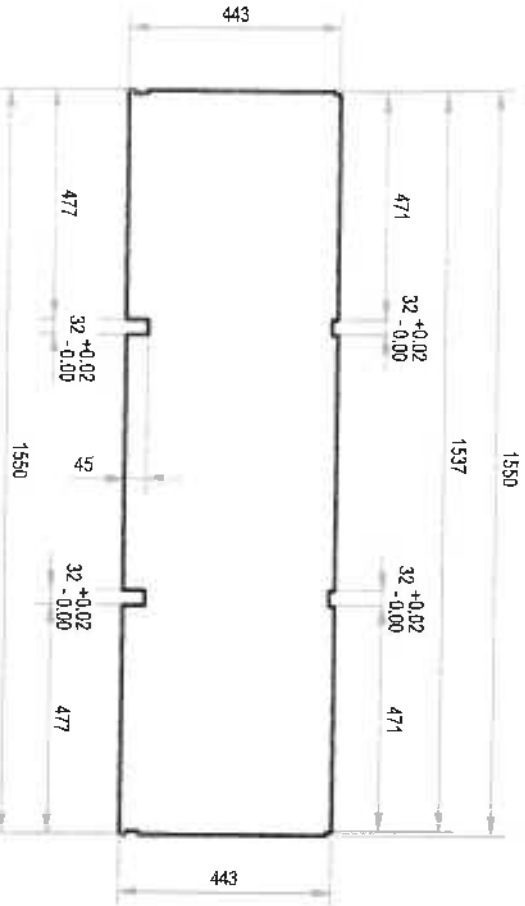

QUANTITY: 6

DETAIL A-5.4:

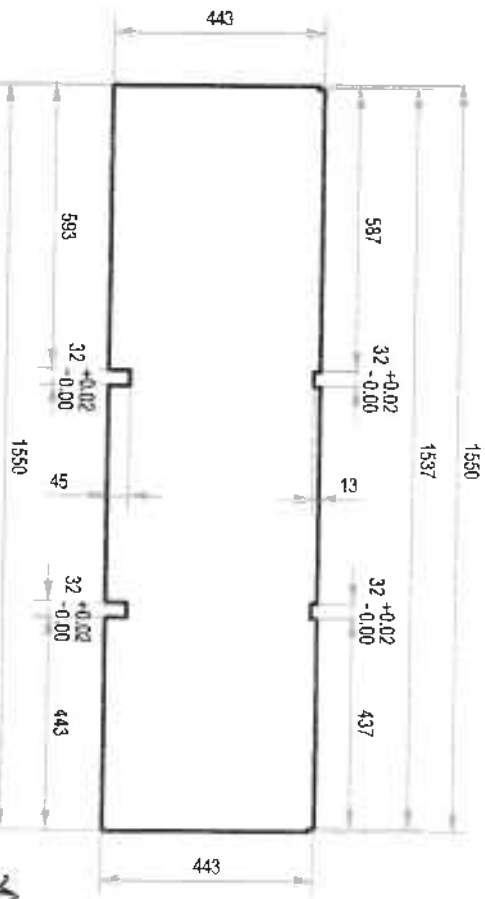

QUANTITY: 1

GALVANIZED SHEET GAUGE #18, PAINTED



PROJECT TITLE
MOBILE TRAINING LABORATORY

Scale 1:16
Sheet No. 1/1

Handwritten initials and a north arrow symbol.

| MTL BOX COVER FRAME, SIDEWAY SWING | | | |
|------------------------------------|------------------------------|-------------|------|
| NO. | MATERIAL | LENGTH, mm | Qty. |
| 1 | Gauge #18 G.I. sheet | 1,009 x 835 | 2 |
| 2 | 1" x 1" x 1.5 mm square tube | 968,25 | 4 |
| 3 | 1" x 1" x 1.5 mm square tube | 928,25 | 2 |
| 4 | 1" x 1" x 1.5 mm square tube | 793,65 | 4 |
| 5 | 1" x 1" x 1.5 mm square tube | 369,825 | 8 |
| 6 | 2" x 2mm piano hinge | 968 | 2 |
| TOTAL | | | 22 |

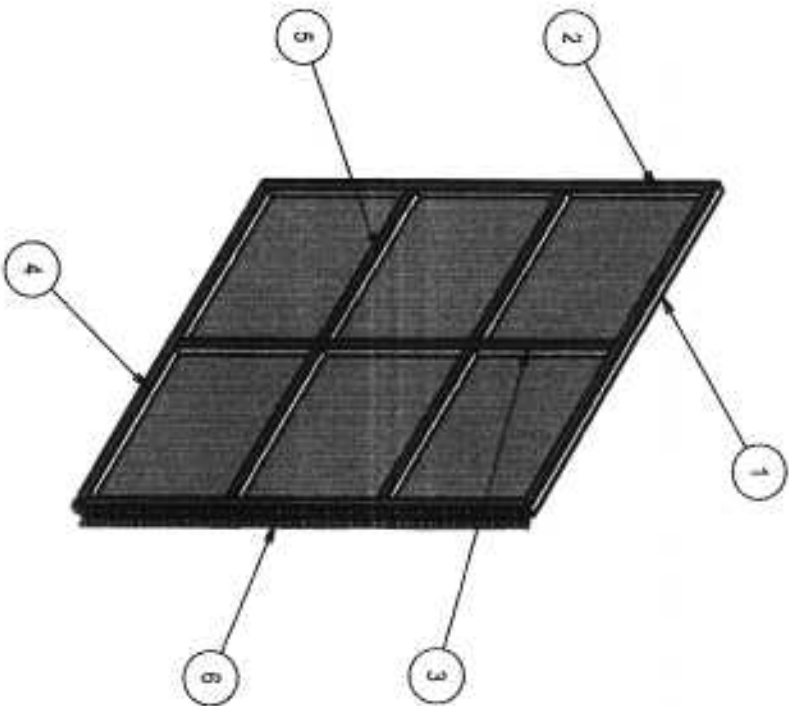

MTL DOOR FRAME



TECHNICAL
EDUCATION AND
SKILLS
DEVELOPMENT
AUTHORITY

PROJECT TITLE
**MOBILE TRAINING
LABORATORY**

21

DATE: 07-2015

Scale: 1:15

1/



A

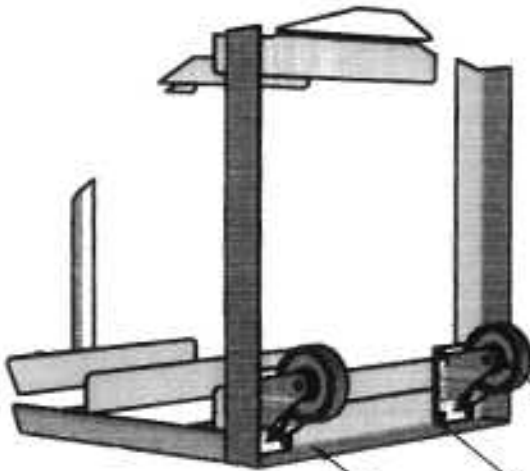

A (1 : 10)

4 pcs. of 4" polyurethane roller wheels with top plate bearing and self-locking; load capacity: 125 lbs. per wheel

Welded in 4" x 4" x 5 mm metal plate

2" x 2" x 3/16" \angle bar, painted

| | | | |
|---|----------------------|---------------------------------------|--------------------------|
|  <p>TECHNICAL EDUCATION AND SKILLS DEVELOPMENT AUTHORITY</p> | PROJECT TITLE | <p>MOBILE TRAINING LABORATORY</p> | <p>Sheet No. 1 /</p> |
| | <p>Drawn by: JPA</p> | | |

78

N

98

DETAIL F: RUBBER DOOR SEAL

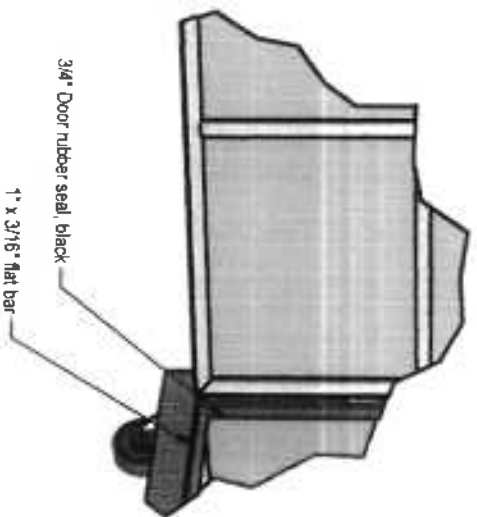
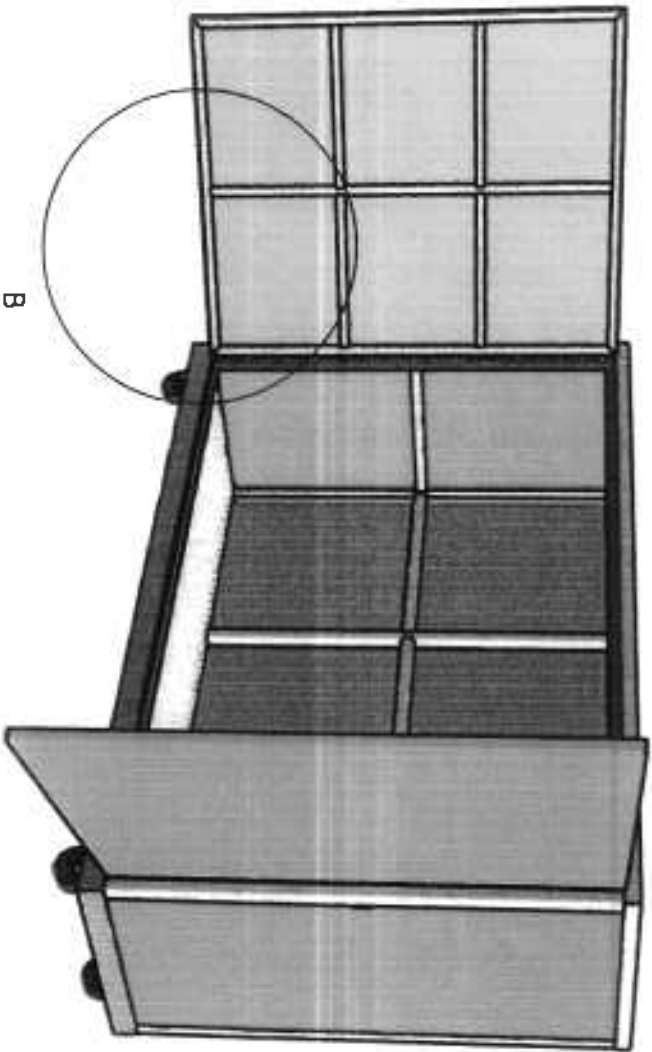

B (1:10)



TECHNICAL
EDUCATION AND
SKILLS
DEVELOPMENT
AUTHORITY

PROJECT TITLE
MOBILE TRAINING
LABORATORY

Drawn by: JSA

Scale: 1:25

Sheet No:
1 /

18

N

91

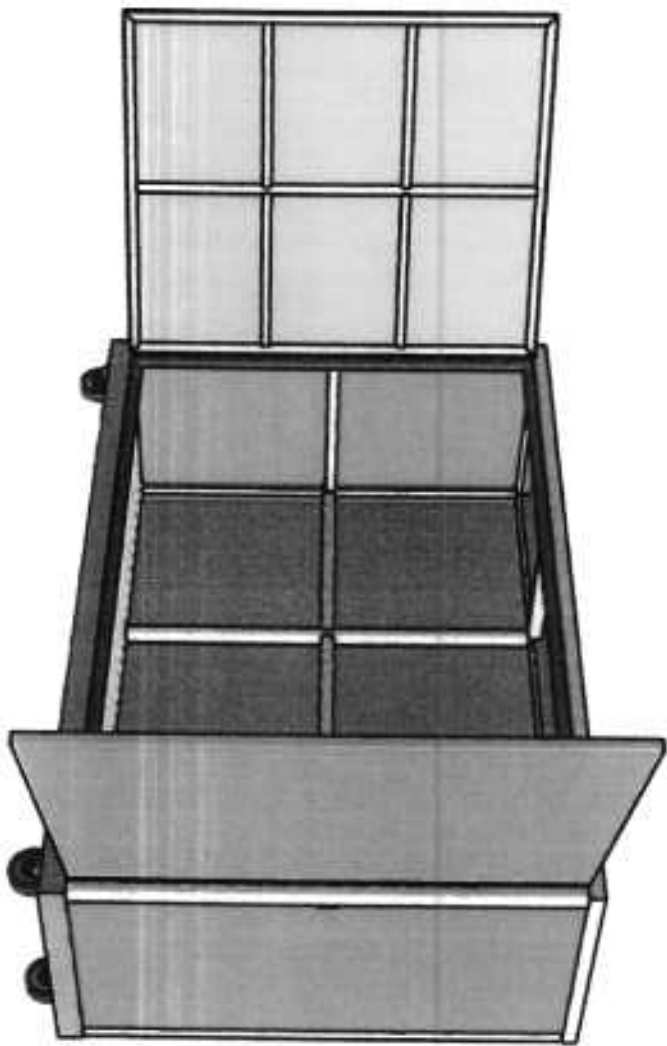

Include 2-sides metal handle
and lock with padlock for the
door (not shown in the drawing)

7

| | | | |
|---|--|----------------------------|------|
|  | TECHNICAL EDUCATION AND SKILLS DEVELOPMENT AUTHORITY | | |
| | PROJECT TITLE | MOBILE TRAINING LABORATORY | REV |
| DESIGNED BY | SCALE | DRAWN BY | DATE |
| JSA | 1:15 | | 1/ |

pt
sk

COMPARATIVE TECHNICAL SPECIFICATION

| TESDA'S SPECIFICATIONS | | BIDDER'S SPECIFICATIONS | | |
|------------------------|---|---|------------------|----------------|
| No. | Item | Specifications | Item/Brand/Model | Specifications |
| Lot 2 | Appliance Repair NC II with Toolbox MTL Box No. 2 | Please refer to the attached drawing | | |

Name of Bidder: _____

Name and Signature of Authorized Representative: _____
 Position/Designation: _____
 Date: _____

7

Handwritten signature

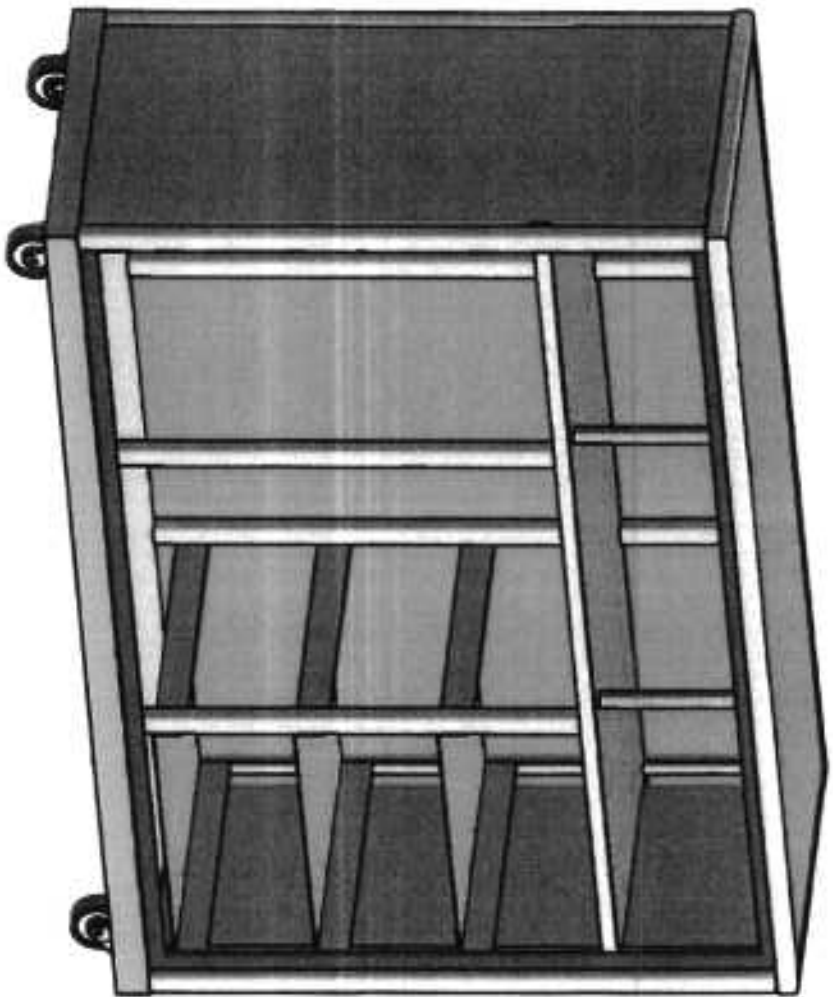

MTL BOX NO. 2
(APPLIANCE REPAIR)
QUANTITY:
 (The door is not shown in the drawing)

7 8 24



TECHNICAL
 EDUCATION AND
 SKILLS
 DEVELOPMENT
 AUTHORITY

PROJECT TITLE
**MOBILE TRAINING
 LABORATORY**

DRAWN BY: J.A.

SCALE: 1:1

SHEET NO:
 1 /

| MTL BOX 2 FRAME | | | |
|-----------------|---|------------|------|
| NO. | MATERIAL | LENGTH, mm | Qty. |
| 1 | 2" x 2" x 3/16" angle bar | 1,800.00 | 2 |
| 2 | 2" x 2" x 3/16" angle bar | 500.00 | 2 |
| 3 | 1 1/4" x 1 1/4" x 2 mm square tube | 493.65 | 2 |
| 4 | 1 1/4" x 1 1/4" x 2 mm square tube | 968.25 | 6 |
| 5 | 1 1/4" x 1 1/4" x 2 mm square tube | 1,500.00 | 2 |
| 6 | 1 1/4" x 1 1/4" x 2 mm square tube | 500.00 | 2 |
| 7 | 1 1/4" x 1 1/4" x 2 mm square tube | 436.50 | 2 |
| 8 | 1 1/4" x 1 1/4" x 2 mm square tube | 1,473.00 | 1 |
| 9 | 1 1/4" x 1 1/4" x 2 mm square tube | 695.00 | 2 |
| 10 | 1" x 1" x 1.5 mm square tube | 393.25 | 2 |
| 11 | 1" x 1" x 1.5 mm square tube | 392.04 | 2 |
| 12 | 1" x 1" x 1.5 mm square tube | 1,536.50 | 1 |
| 13 | 1" x 1" x 1.5 mm square tube | 968.25 | 2 |
| 14 | Gauge #18 GI sheet, 2" x 2" @ 90 degrees bend | 431.70 | 6 |
| 15 | 3/4" x 3/4" x 1.5 mm square tube | 247.04 | 2 |
| TOTAL | | | 36 |

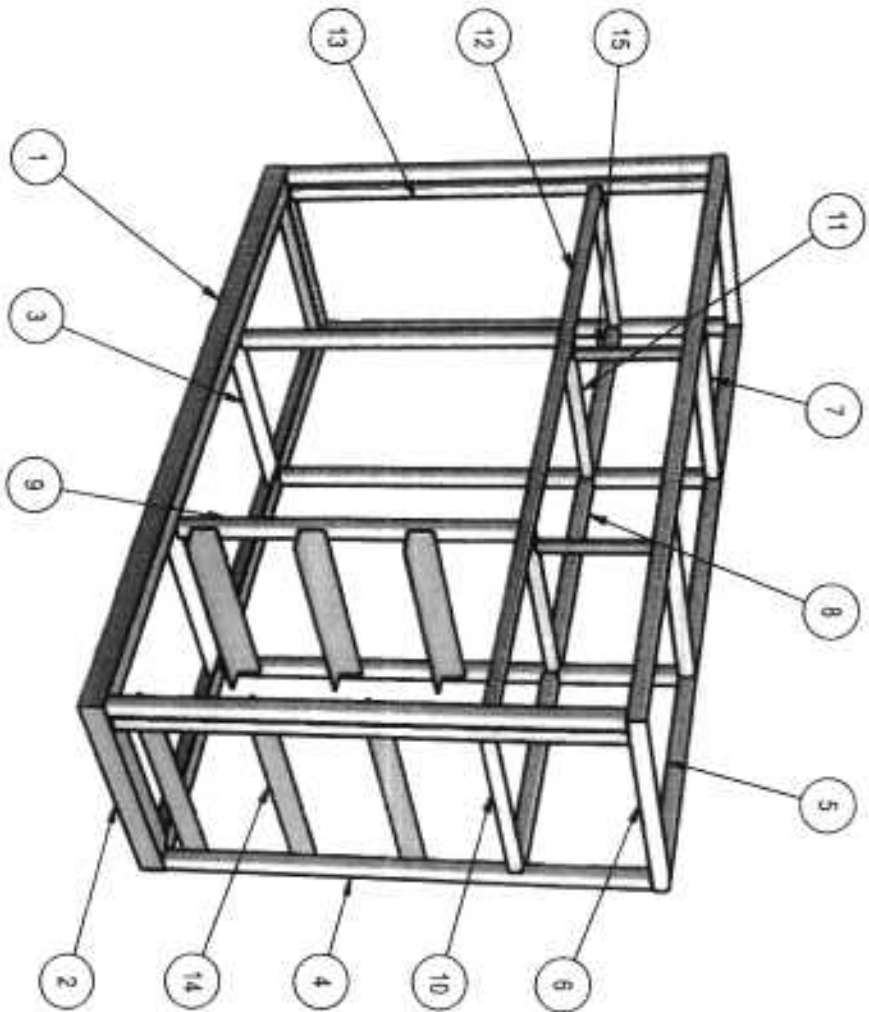

**MTL BOX NO. 2 FRAME
(APPLIANCE REPAIR)**
(The door is not shown in the drawing)

PRODUCED BY AN AUTODESK EDUCATIONAL PRODUCT



TECHNICAL
EDUCATION AND
SKILLS
DEVELOPMENT
AUTHORITY

PROJECT TITLE
**MOBILE TRAINING
LABORATORY**

Drawing No. 204 Scale 1:15

Sheet 1/1

Handwritten initials and marks:
- 28
- 28
- NW

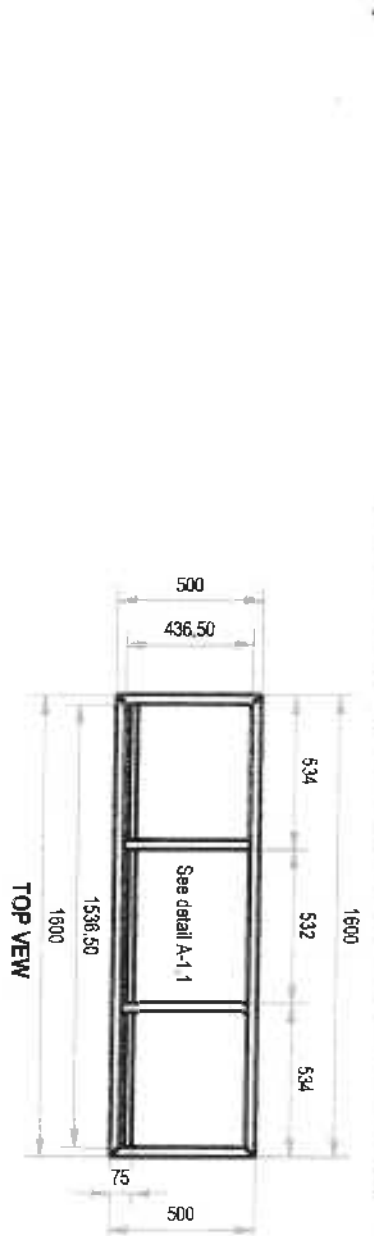

TOP VIEW

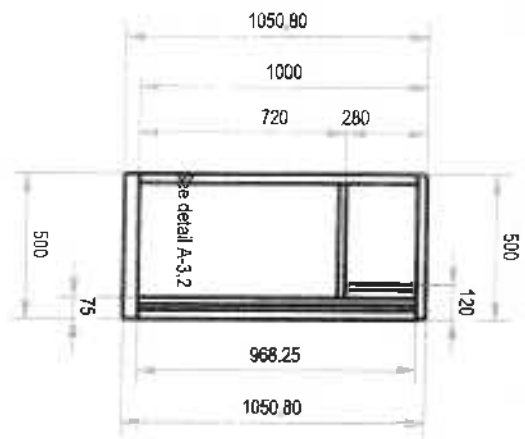

LEFT SIDE VIEW



FRONT VIEW

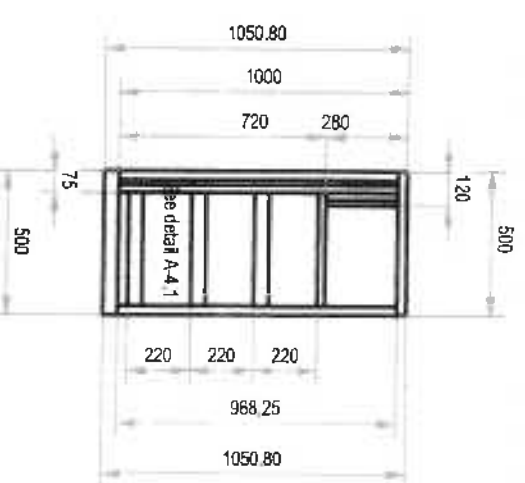

RIGHT SIDE VIEW

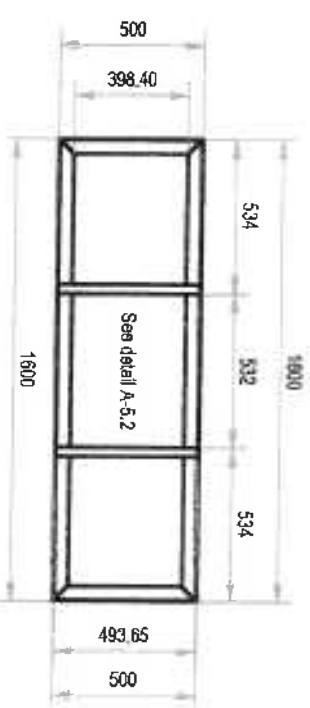

BOTTOM VIEW

MTL BOX NO. 2 FRAME
(APPLIANCE REPAIR)
 (The door is not shown in the drawing)

MTL BOX NO. 2
 All materials must be painted with anti-corrosive primer
 Tube and bar are coated with light gray epoxy finish paint

TECHNICAL EDUCATION AND SKILLS DEVELOPMENT AUTHORITY

PROJECT TITLE: **MOBILE TRAINING LABORATORY**

Drawn by: [Signature] Scale: 1:25 Sheet No.: [Signature]

DETAIL A-1.1:

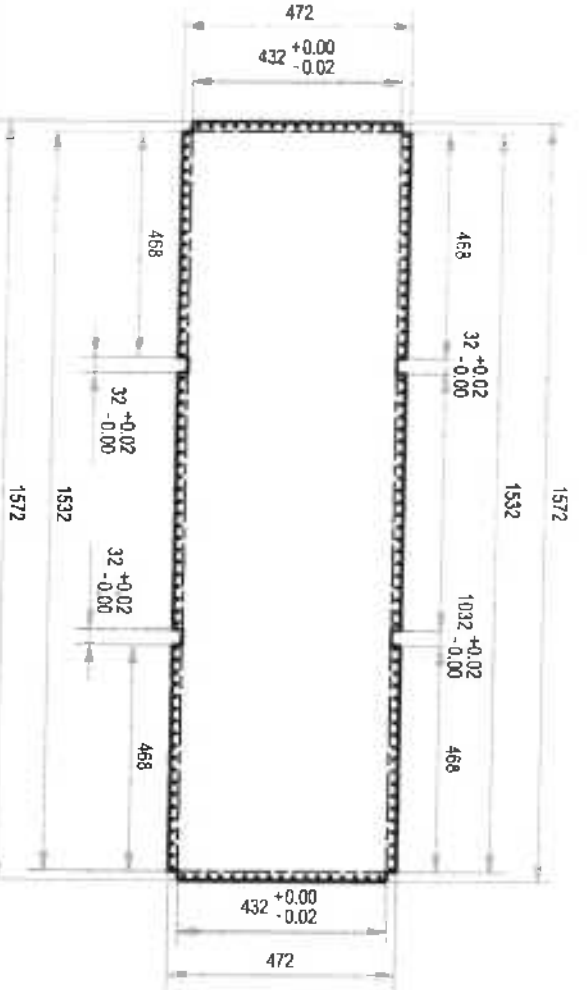

QUANTITY: 5

DETAIL A-1.2:

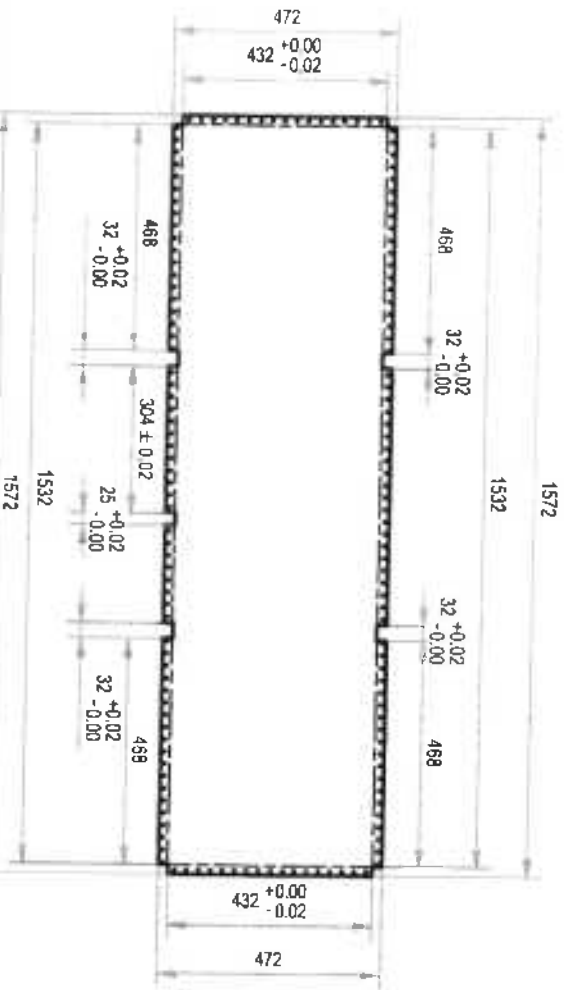

QUANTITY: 2

DETAIL A-1.3:

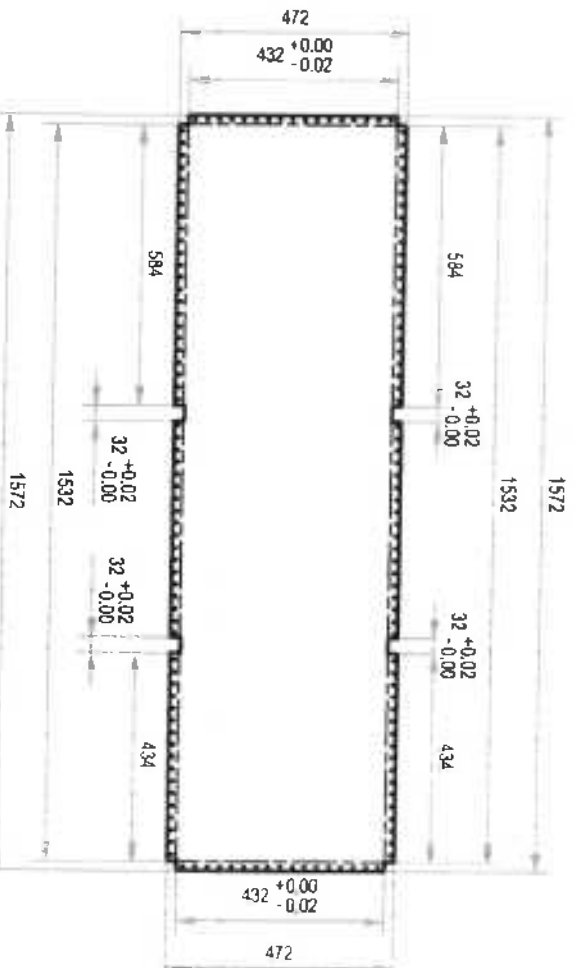

QUANTITY: 1

DETAIL A-1.4:

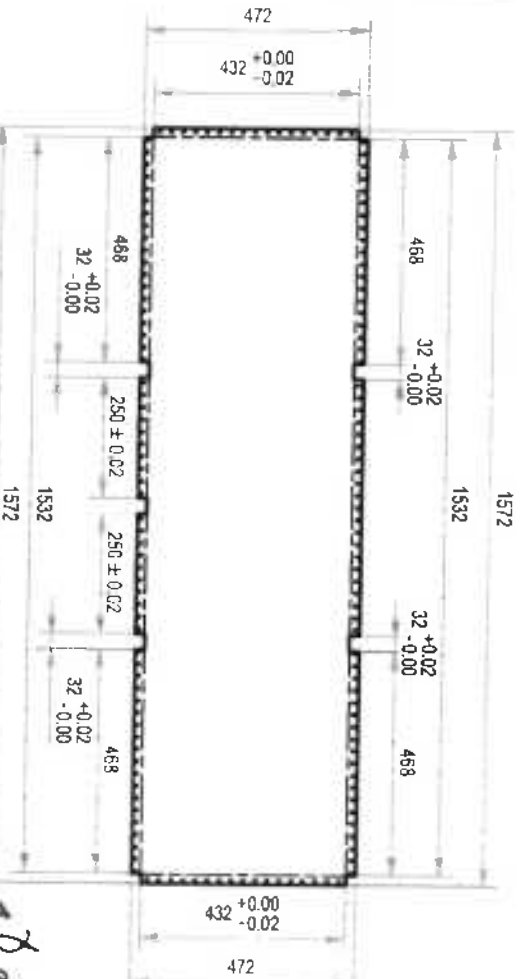

QUANTITY: 2

FLAT PATTERN: GALVANIZED SHEET GAUGE #18, PAINTED

Use 3/16" blind rivet spaced @ 1" O.C



TECHNICAL EDUCATION AND SKILLS DEVELOPMENT AUTHORITY

PROJECT TITLE
MOBILE TRAINING LABORATORY

DESIGNED BY: JPS

Scale: 1:15

Revised No. 1/

DETAIL A-2.1:

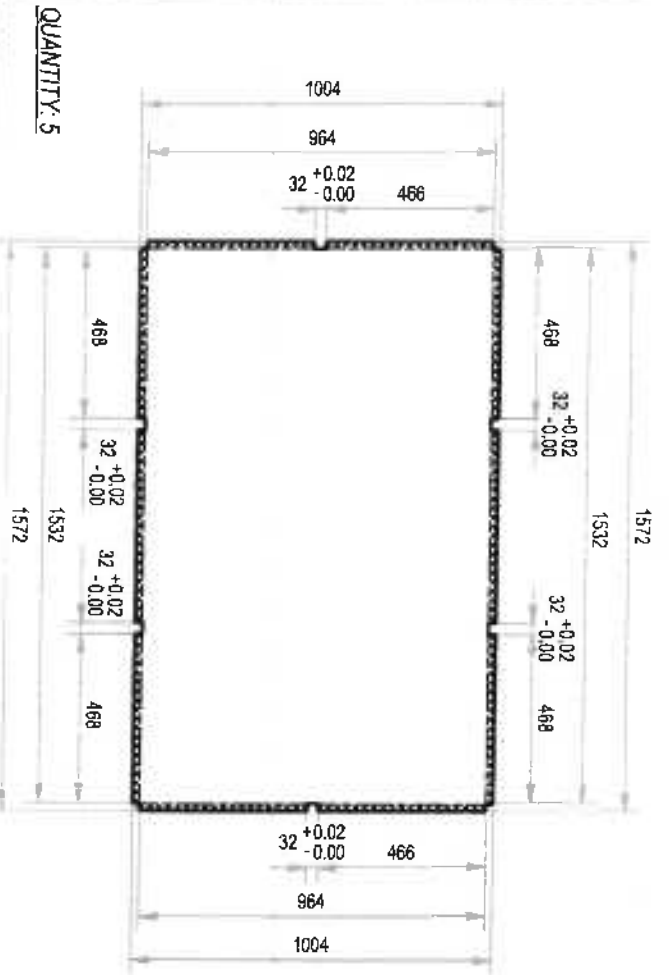

QUANTITY: 5

DETAIL A-2.2:

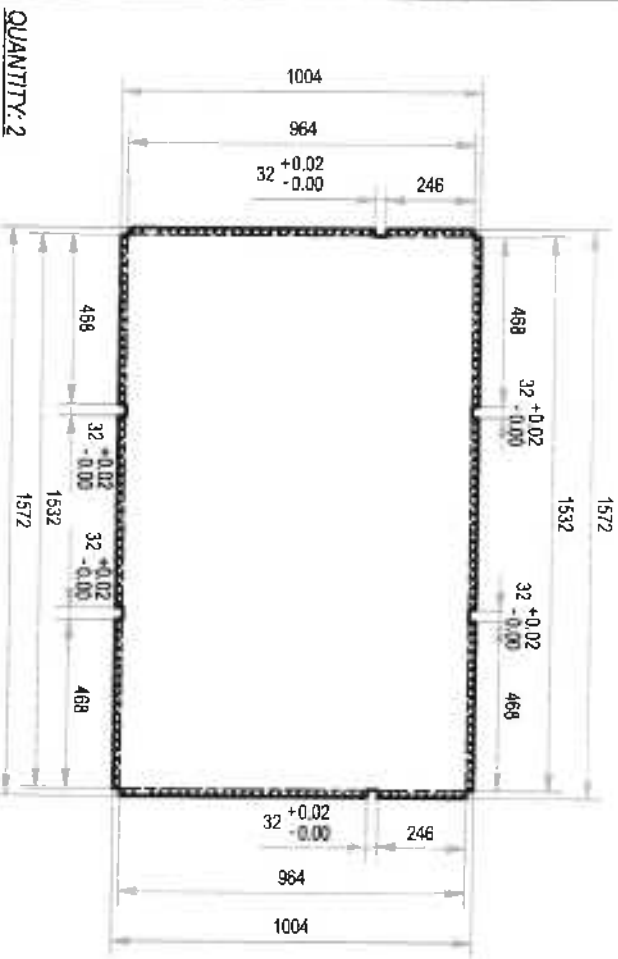

QUANTITY: 2

FLAT PATTERN: GALVANIZED SHEET GAUGE #18, PAINTED

DETAIL A-2.3:

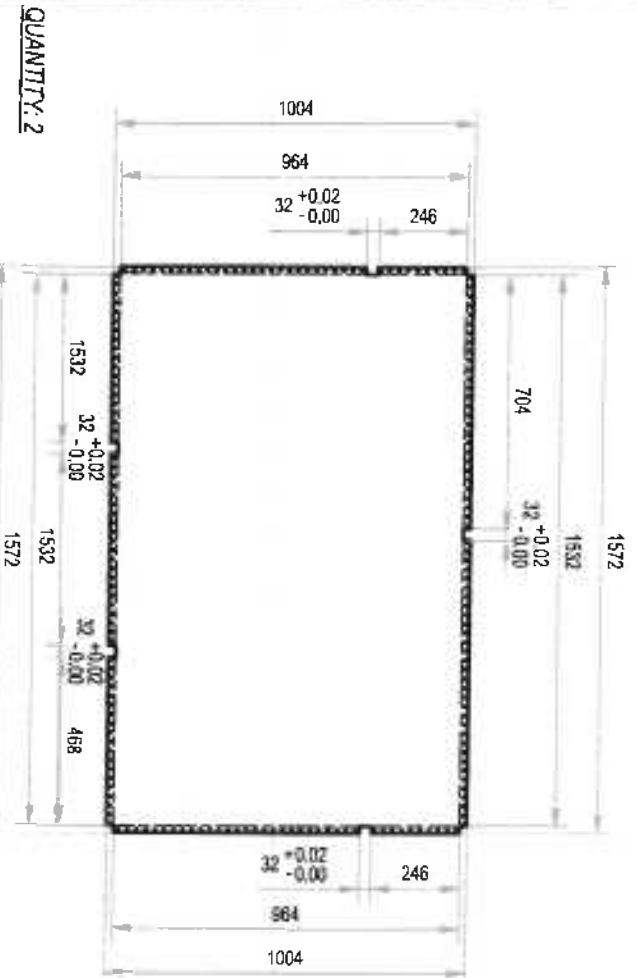

QUANTITY: 2

DETAIL A-2.4:

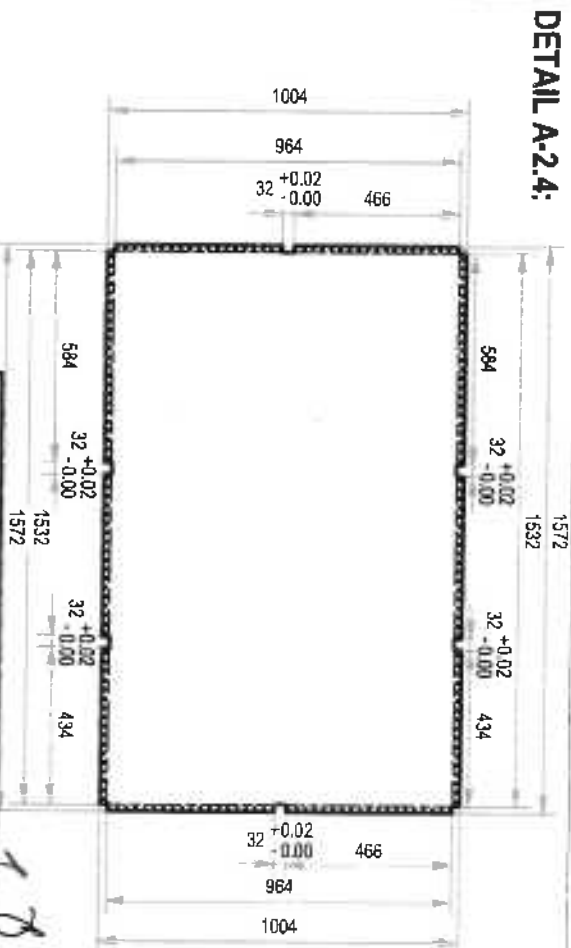

QUANTITY: 1

Use 3/6" blind rivet spaced @ 1" O.C.



TECHNICAL EDUCATION AND SKILLS DEVELOPMENT AUTHORITY

PROJECT TITLE
MOBILE TRAINING LABORATORY

DRAWN BY: JSA

Scale: 1:20

Sheet No: 1/

1/28

DETAIL A-3.1:

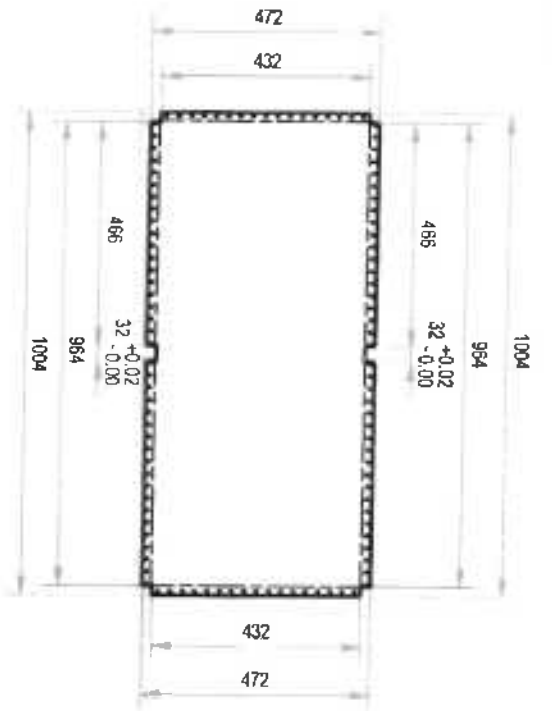

QUANTITY: 5

DETAIL A-3.3:

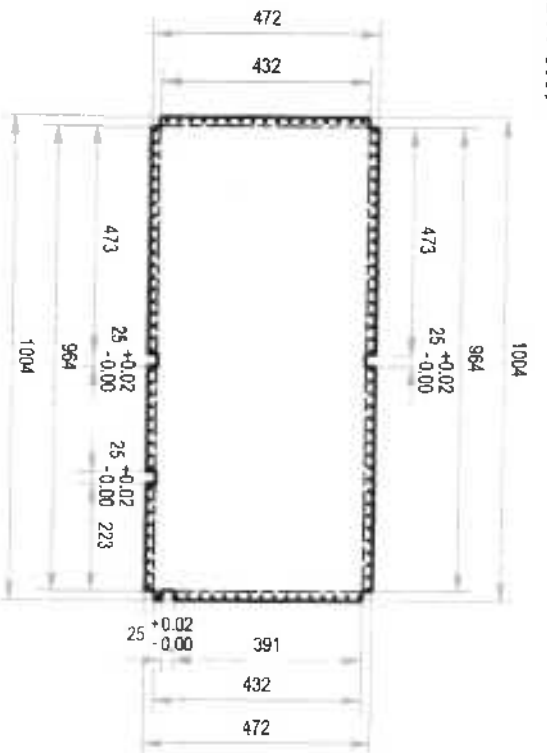

QUANTITY: 1

DETAIL A-3.4:

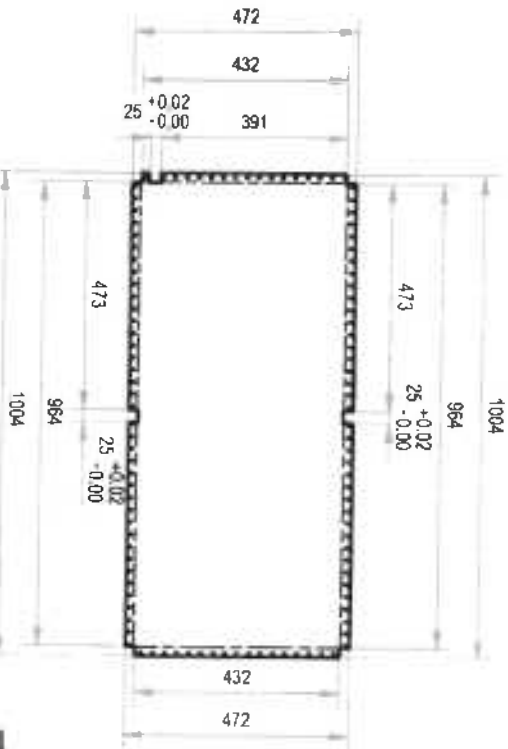

QUANTITY: 4

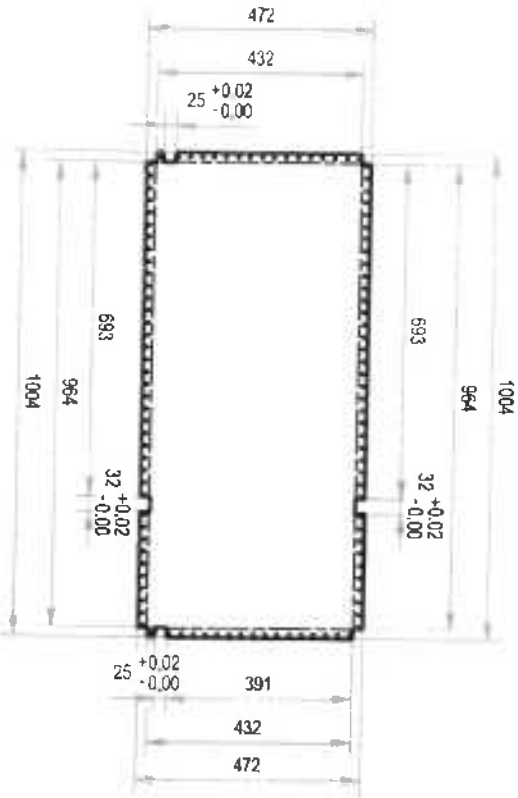

FLAT PATTERN: GALVANIZED SHEET GAUGE #18, PAINTED

PRODUCED BY AN AUTODESK EDUCATIONAL PRODUCT

QUANTITY: 2

Use 3/16" blind rivet spaced @ 1" O.C.



TECHNICAL EDUCATION AND SKILLS DEVELOPMENT AUTHORITY

PROJECT TITLE: MOBILE TRAINING LABORATORY

Scale: 1/15

DATE: 1/24

Scale: 1/15

1/

DETAIL A-4.1:

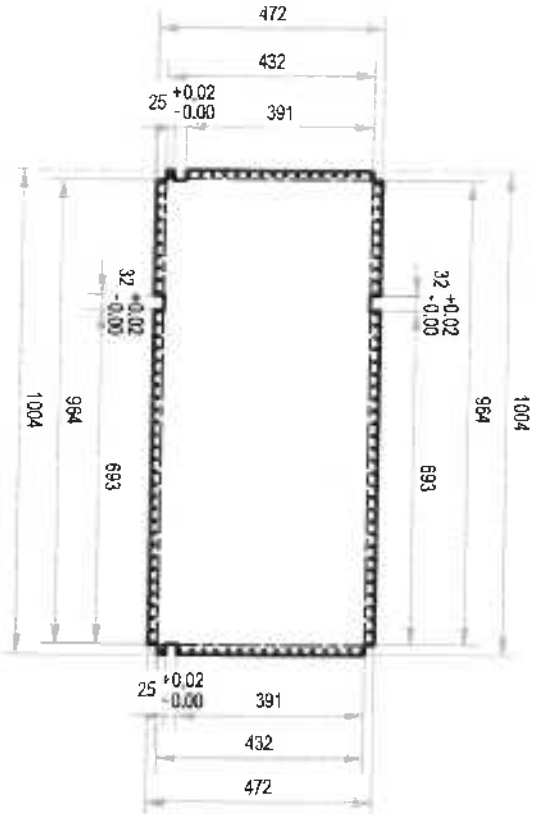

QUANTITY: 4

DETAIL A-4.2:

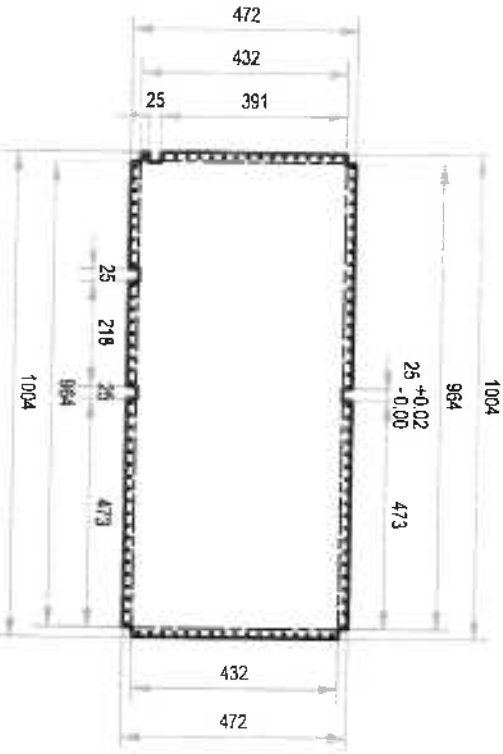

QUANTITY: 2

DETAIL A-4.3:

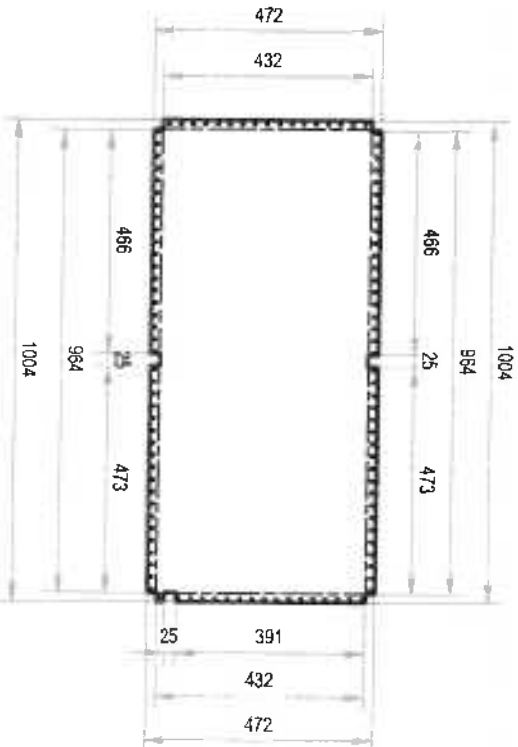

QUANTITY: 2

FLAT PATTERN: GALVANIZED SHEET GAUGE #18, PAINTED

Use 3/16" blind rivet spaced @ 1" O.C.



TECHNICAL
EDUCATION AND
SKILLS
DEVELOPMENT
AUTHORITY

PROJECT TITLE
**MOBILE TRAINING
LABORATORY**

DESIGNER: [Name]

Scale: 1:1.5

Sheet No. 1/1

78 OK

DETAIL A-5.1:

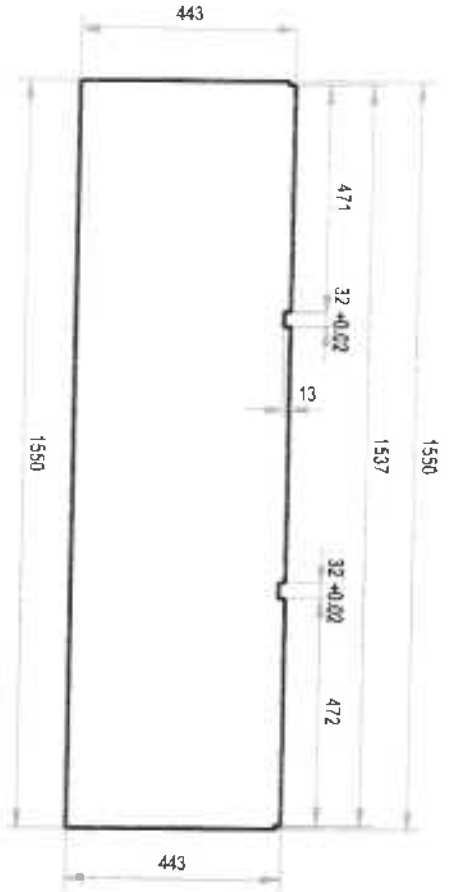

QUANTITY: 1

DETAIL A-5.2:

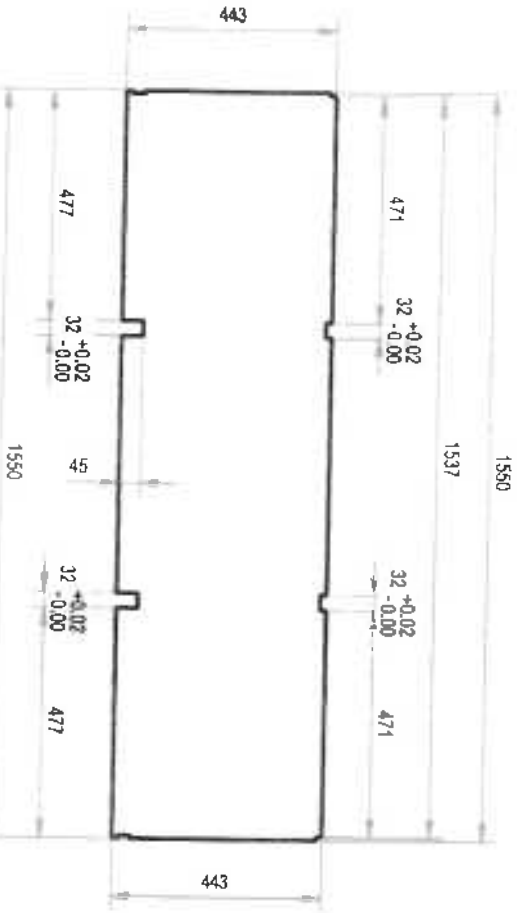

QUANTITY: 6

DETAIL A-5.3:

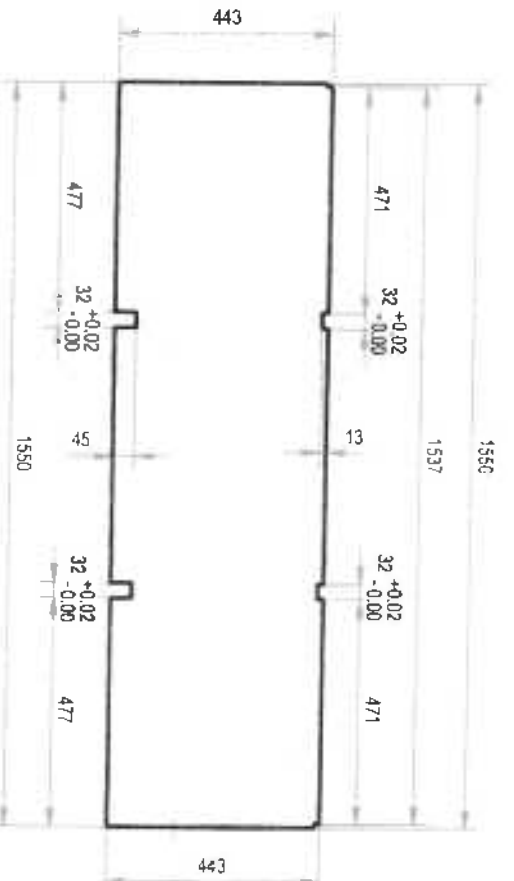

QUANTITY: 2

DETAIL A-5.4:

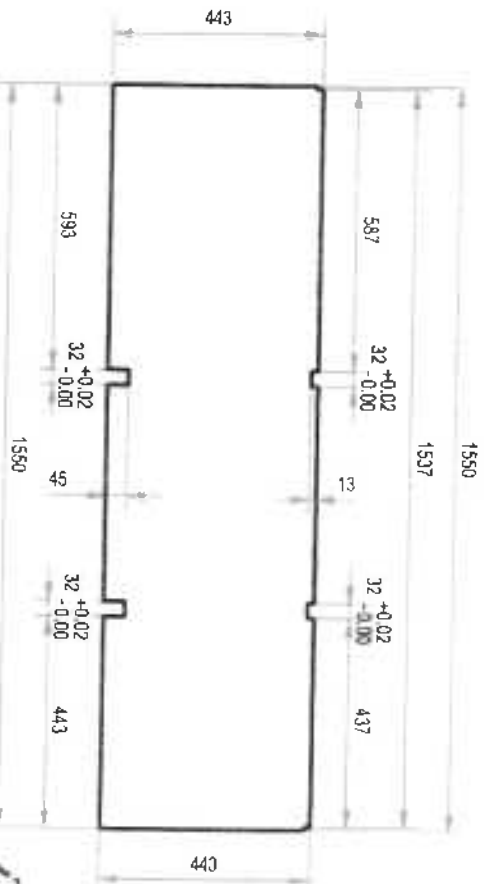

QUANTITY: 1

GALVANIZED SHEET GAUGE #18, PAINTED

PRODUCED BY AN AUTODESK EDUCATIONAL PRODUCT



TECHNICAL
EDUCATION AND
SKILLS
DEVELOPMENT
AUTHORITY

PROJECT TITLE
MOBILE TRAINING
LABORATORY

NW

Drawn by: J.A.

Scale: 1:15

Sheet No: 1/1

DETAIL B-1.1:

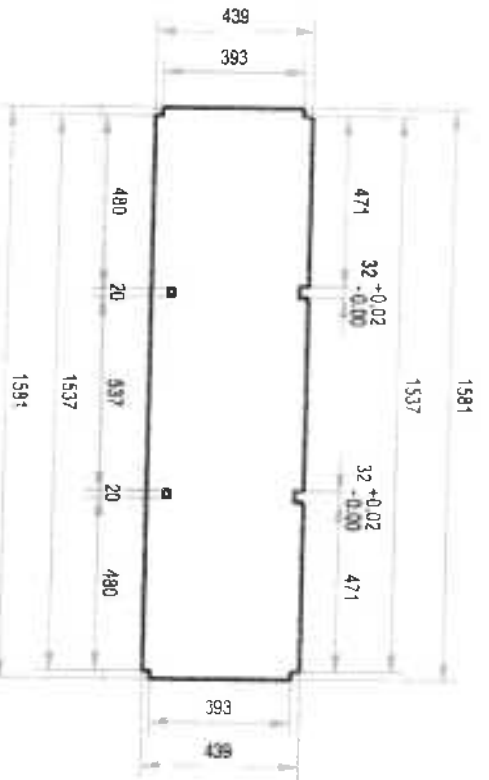

QUANTITY: 2

DETAIL B-1.2:

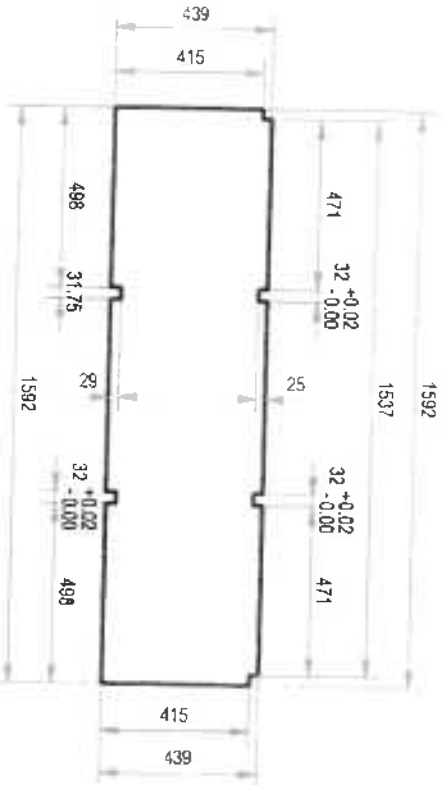

QUANTITY: 1

GALVANIZED SHEET GAUGE #18, PAINTED

PRODUCED BY AN AUTODESK EDUCATIONAL PRODUCT

DETAIL B-1.3:

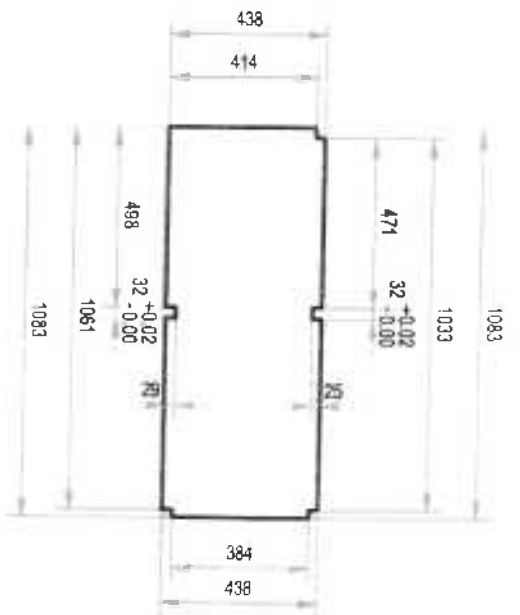

QUANTITY: 1

DETAIL B-1.4:



QUANTITY: 2



TECHNICAL
EDUCATION AND
SKILLS
DEVELOPMENT
AUTHORITY

PROJECT TITLE
**MOBILE TRAINING
LABORATORY**

78 *af*

N

Drawn by: JVA Scale: 1:20 Date: 1/

DETAIL C-1.1:

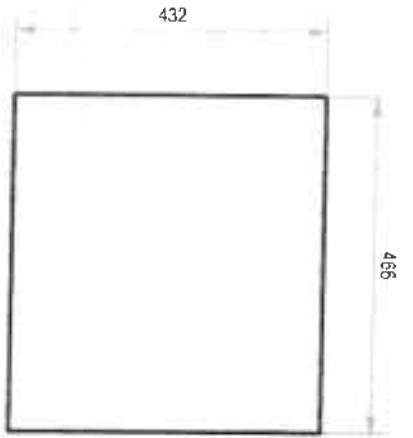

QUANTITY: 15

DETAIL C-1.2:

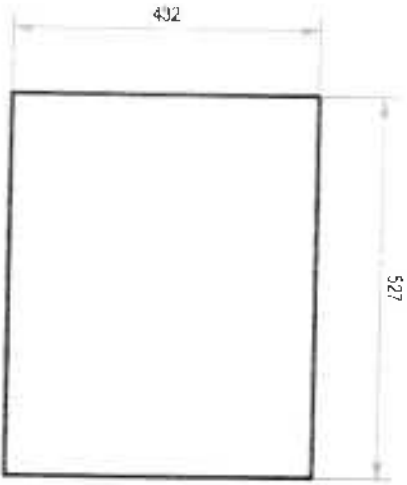

QUANTITY: 9

GALVANIZED SHEET GAUGE #18, PAINTED

DETAIL C-1.3:

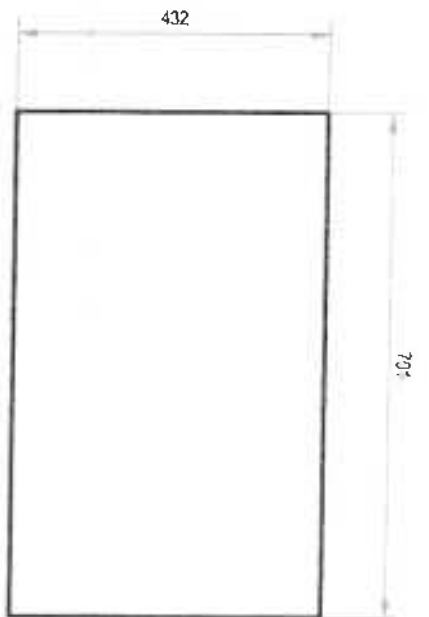

QUANTITY: 2

DETAIL D-1.1:

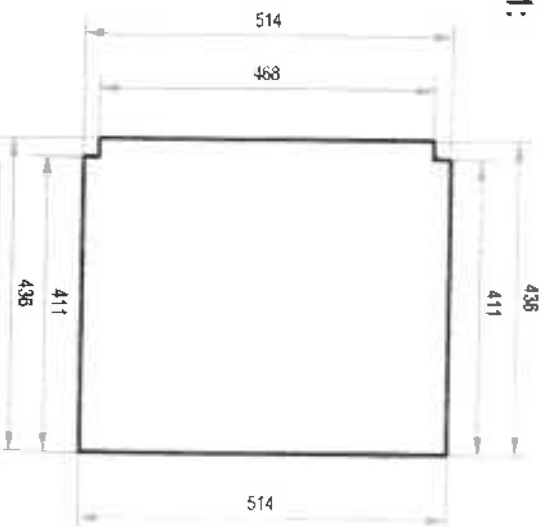

QUANTITY: 1



TECHNICAL EDUCATION AND SKILLS DEVELOPMENT AUTHORITY

PROJECT TITLE: MOBILE TRAINING LABORATORY

DATE: 1/1/10

DRAWN BY: JVA

SCALE: 1:10

SHEET NO: 1/

Handwritten initials and date: JVA 1/1/10

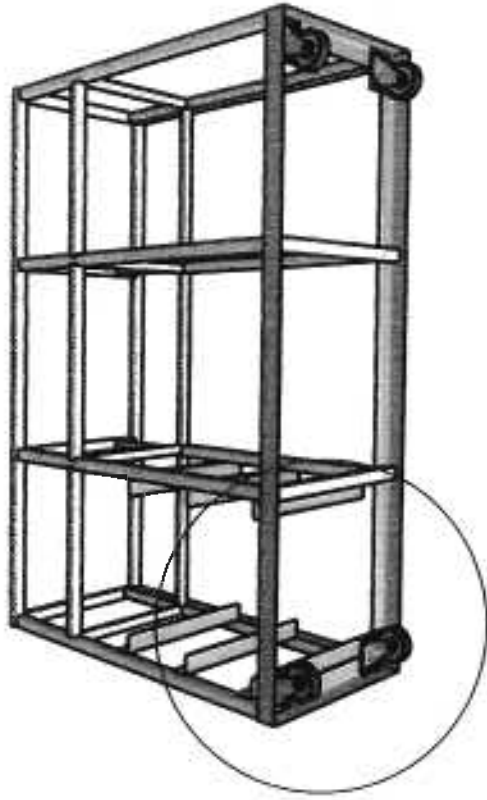

A

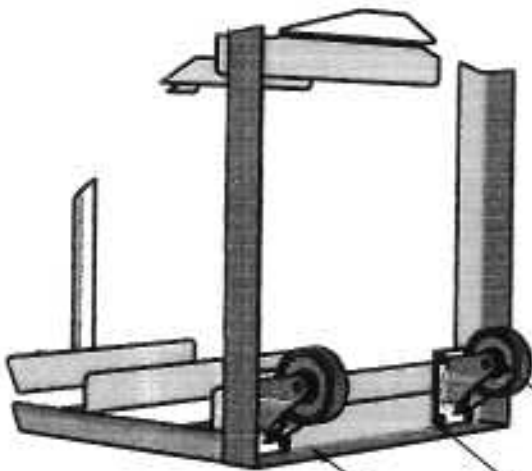

A (1 : 10)

4 pcs. of 4" polyurethane roller wheels with top plate bearing and self-locking; load capacity: 125 lbs. per wheel

Welded in 4" x 4" x 5 mm metal plate

2" x 2" x 3/16" bar, painted



TECHNICAL
EDUCATION AND
SKILLS
DEVELOPMENT
AUTHORITY

PROJECT TITLE:
**MOBILE TRAINING
LABORATORY**

Sheet No.
1 /

DRAWN BY: JPS

Scale: 1:20

Sheet No.
1 /

Handwritten signature and date: T B 2019

DETAIL F: RUBBER DOOR SEAL

PRODUCED BY AN AUTODESK EDUCATIONAL PRODUCT

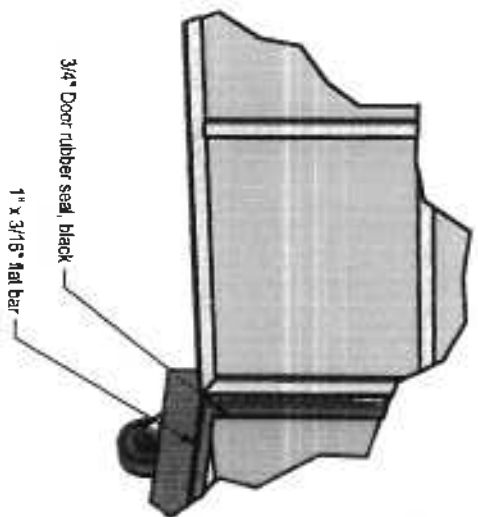
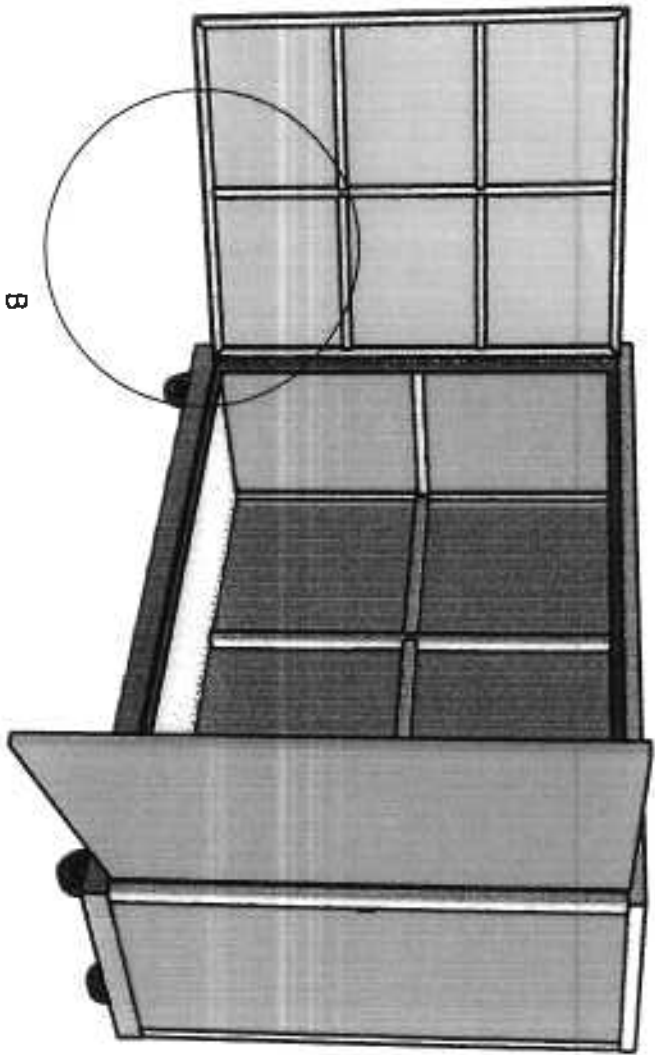

B (1:10)

18
OK
gale



TECHNICAL
EDUCATION AND
SKILLS
DEVELOPMENT
AUTHORITY

PROJECT TITLE
MOBILE TRAINING
LABORATORY

DRAWN BY J/A

Scale 1:25

Sheet No. 1/1

PRODUCED BY AN AUTODESK EDUCATIONAL PRODUCT

PRODUCED BY AN AUTODESK EDUCATIONAL PRODUCT

| MTL BOX COVER FRAME, SIDEWAY SWING | | | |
|------------------------------------|------------------------------|-------------|------|
| NO. | MATERIAL | LENGTH, mm | Qty. |
| 1 | Gauge #18 G.I. sheet | 1,009 x 835 | 2 |
| 2 | 1" x 1" x 1.5 mm square tube | 988.25 | 4 |
| 3 | 1" x 1" x 1.5 mm square tube | 928.25 | 2 |
| 4 | 1" x 1" x 1.5 mm square tube | 793.65 | 4 |
| 5 | 1" x 1" x 1.5 mm square tube | 369.825 | 8 |
| 6 | 2" x 2mm piano hinge | 968 | 2 |
| TOTAL | | | 22 |

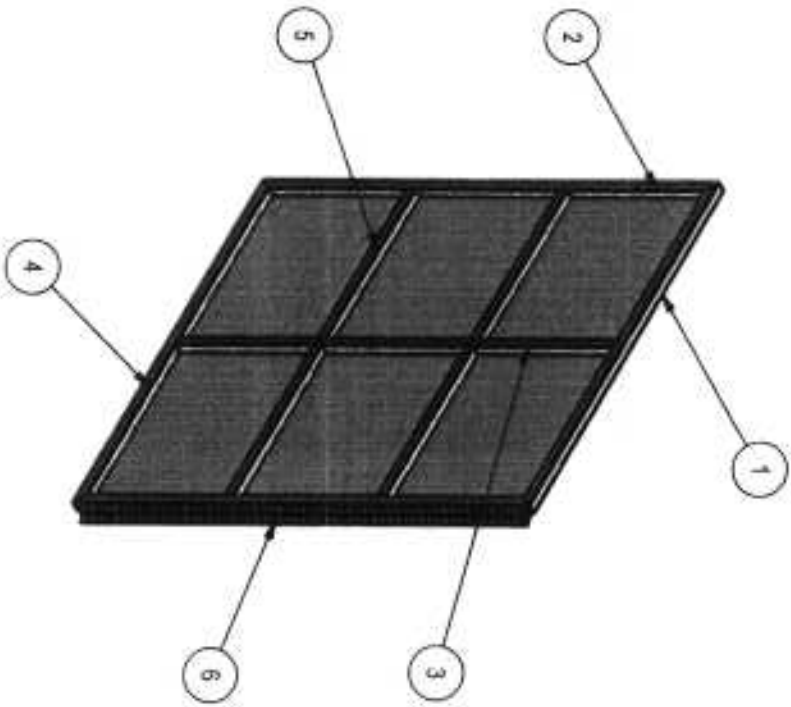

MTL DOOR FRAME



TECHNICAL
EDUCATION AND
SKILLS
DEVELOPMENT
AUTHORITY

PROJECT TITLE
MOBILE TRAINING
LABORATORY

DRAWN BY: J.S.

Scale 1:15

Drawn No
1/

N

7 of 10

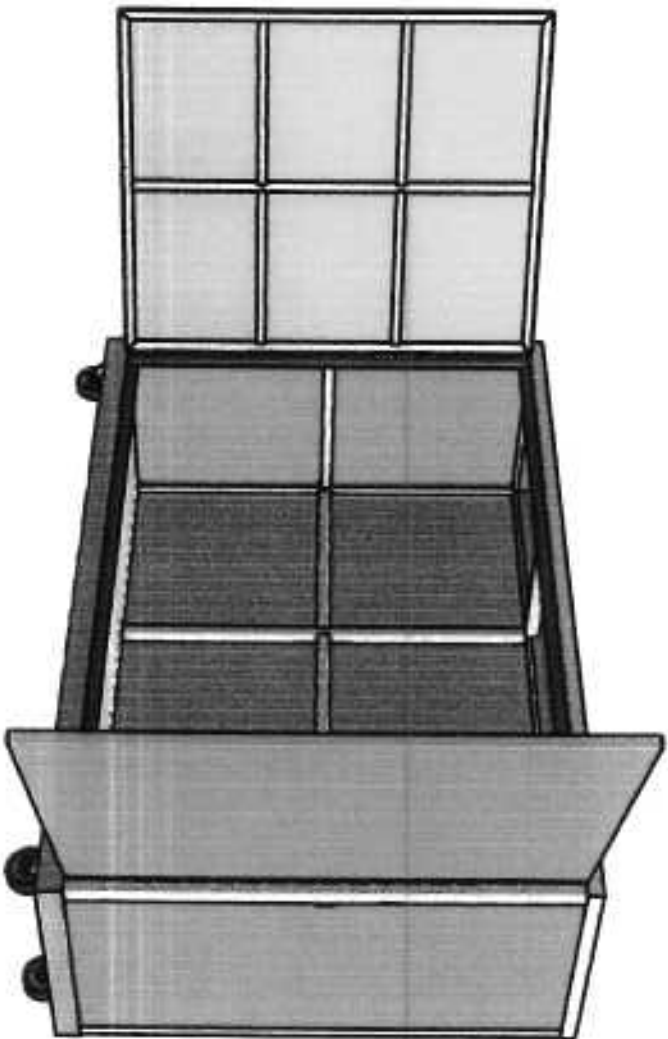

Include 2-sides metal handle
and lock with padlock for the
door (not shown in the drawing)

7 2 18
gou

| | | | | |
|---|-------------------------------|----------------|-------------|---------------|
|  <p>TECHNICAL EDUCATION AND SKILLS DEVELOPMENT AUTHORITY</p> | PROJECT TITLE | DATE: 07-09-15 | Scale: 1:15 | Sheet No: 1 / |
| | MOBILE TRAINING LABORATORY | | | |

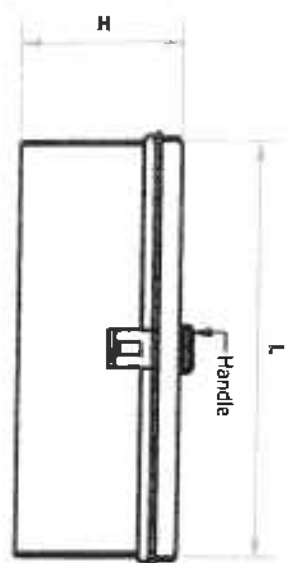

FRONT VIEW

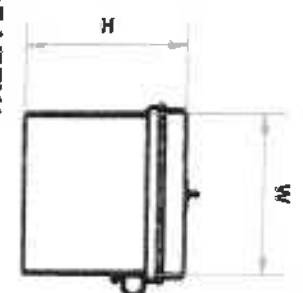

SIDE VIEW

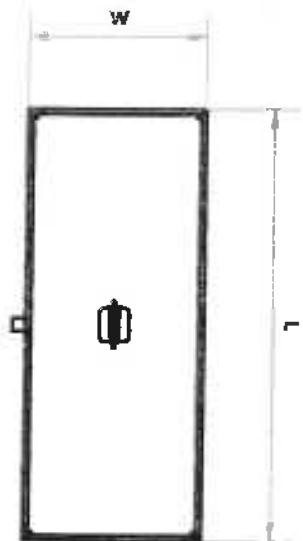

TOP VIEW

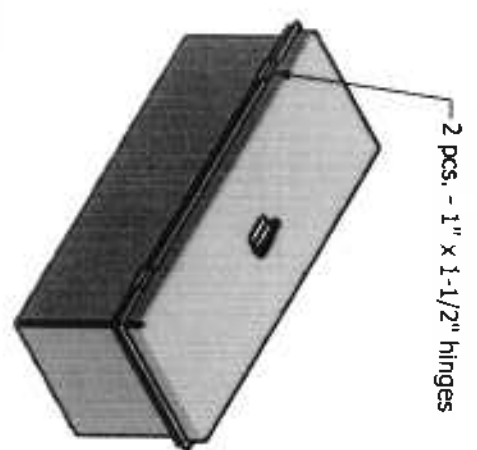

ISOMETRIC VIEW

| TOOLBOX | | | |
|---------|--------------------|---|---------------------|
| NO. | DIMENSION (L x | MATERIAL | NO. OF PCS. PER SET |
| 1 | 18" x 7" x 7" | Small Engine Repair - G.A., #18 galvanized sheet, painted | 12 |
| 3 | 18" x 7" x 8" | Appliance Repair - G.A., #18 galvanized sheet, painted | 6 |
| | 18" x 7" x 8" | Electrical Installation and Maintenance - G.A., #18 galvanized sheet, painted | 6 |
| 4 | 20" x 7" x 8" | Small Engine Repair - G.A., #18 galvanized sheet, painted | 6 |
| 5 | 16" x 20" x 4-1/2" | Cookery - Plastic, white | 3 |
| 6 | 16" x 20" x 4-1/2" | Food Processing - Plastic, white | 3 |



TECHNICAL EDUCATION AND SKILLS DEVELOPMENT AUTHORITY

PROJECT TITLE
COMPACT MOBILE UNIT

Drawn by J.A. Scale 1/8 Sheet No. 1/

78 of 100

COMPARATIVE TECHNICAL SPECIFICATION

| No. | TESDA'S SPECIFICATIONS | | BIDDER'S SPECIFICATIONS | |
|-------|---|--------------------------------------|-------------------------|----------------|
| | Item | Specifications | Item/Brand/Model | Specifications |
| Lot 3 | Bread and Pastry NC II MTL Box No. 3 | Please refer to the attached drawing | | |
| | Bread and Pastry NC II MTL Box No. 4 | Please refer to the attached drawing | | |

Name of Bidder: _____

Name and Signature of Authorized Representative: _____
 Position/Designation: _____
 Date: _____

1
 of M
 pd

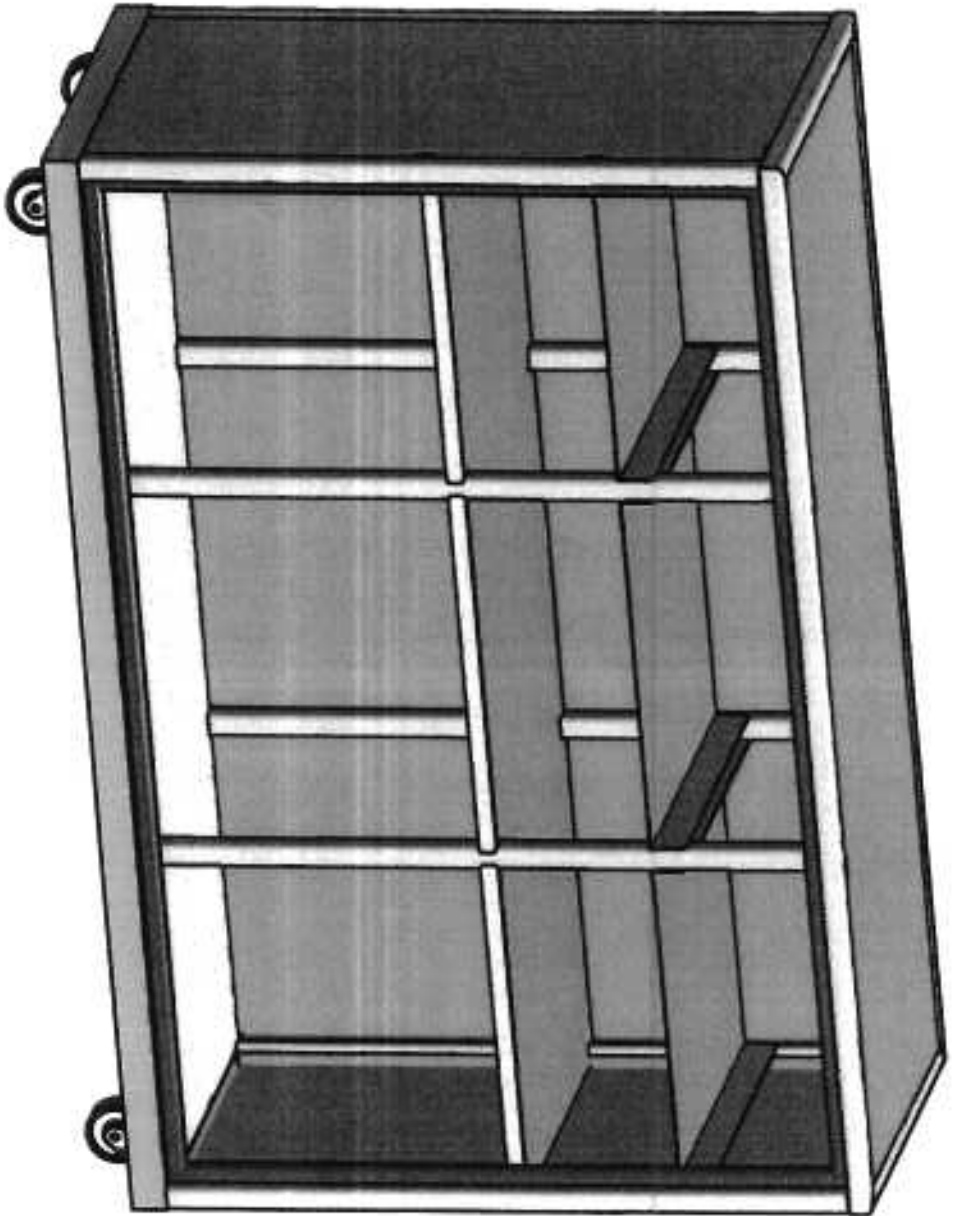

**MTL BOX NO. 3
(BREAD AND PASTRY)
QUANTITY:**
(The door is not shown in the
drawing)

PRODUCED BY AN AUTODESK EDUCATIONAL PRODUCT



TECHNICAL
EDUCATION AND
SKILLS
DEVELOPMENT
AUTHORITY

PROJECT TITLE
**MOBILE TRAINING
LABORATORY**

DRAWN BY: JIN

Scale 1:10

Sheet No.
1 /

Handwritten initials and a checkmark.

| MTL BOX 3 FRAME | | | |
|-----------------|---|------------|------|
| NO. | MATERIAL | LENGTH, mm | Qty. |
| 1 | 2" x 2" x 3/16" angle bar | 1,800.00 | 2 |
| 2 | 2" x 2" x 3/16" angle bar | 500.00 | 2 |
| 3 | 1 1/4" x 1 1/4" x 2 mm square tube | 493.65 | 2 |
| 4 | 1 1/4" x 1 1/4" x 2 mm square tube | 968.25 | 6 |
| 5 | 1 1/4" x 1 1/4" x 2 mm square tube | 1,600.00 | 2 |
| 6 | 1 1/4" x 1 1/4" x 2 mm square tube | 500.00 | 2 |
| 7 | 1 1/4" x 1 1/4" x 2 mm square tube | 436.50 | 2 |
| 8 | 1 1/4" x 1 1/4" x 2 mm square tube | 1,473.00 | 1 |
| 9 | 1 1/4" x 1 1/4" x 2 mm square tube | 967.04 | 2 |
| 10 | 1" x 1" x 1.5 mm square tube | 436.5 | 2 |
| 11 | 1" x 1" x 1.5 mm square tube | 392.04 | 2 |
| 12 | 1" x 1" x 1.5 mm square tube | 1,473.00 | 1 |
| 13 | 1" x 1" x 1.5 mm square tube | 43.25 | 2 |
| 14 | 1" x 1" x 1.5 mm square tube | 225.00 | 2 |
| 15 | Gauge #18 GI sheet, 2' x 2' @ 90 degrees bend | 431.70 | 6 |
| TOTAL | | | 36 |

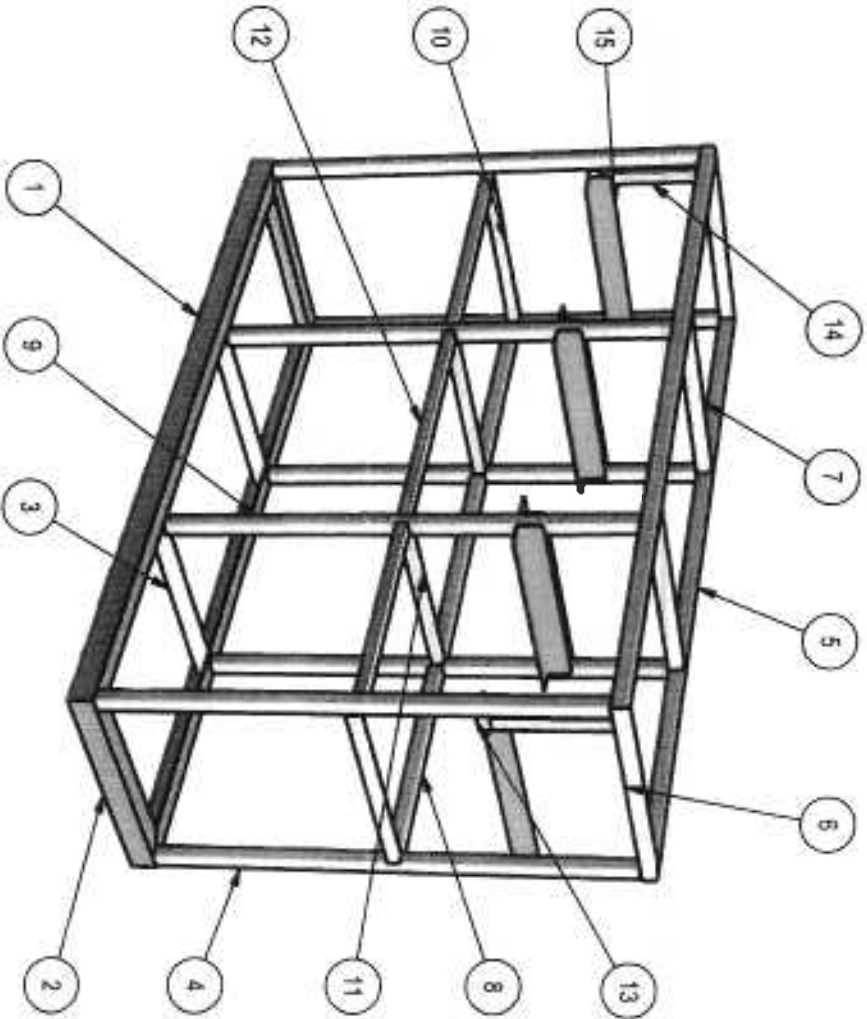

**MTL BOX NO. 3 FRAME
(BREAD AND PASTRY)**
(The door is not shown in the drawing)



**TECHNICAL
EDUCATION AND
SKILLS
DEVELOPMENT
AUTHORITY**

PROJECT TITLE
**MOBILE TRAINING
LABORATORY**

Drawn by: JPA Scale: 1:15 Sheet No: 1/1

Handwritten notes:
7 of 8
of parts

MTL BOX NO. 3
 ☐ All materials must be painted with anti-corrosive primer
 ☐ Tube and bar are coated with light grey epoxy finish paint

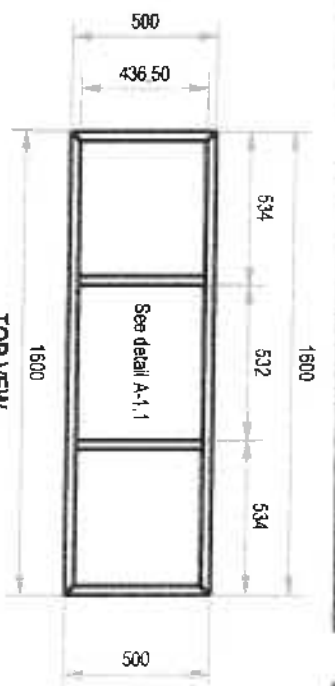

TOP VIEW

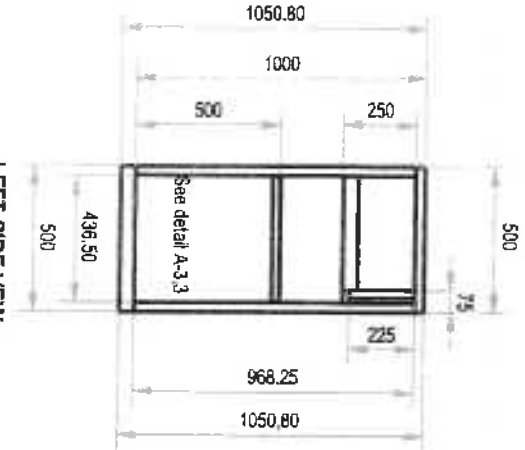

LEFT SIDE VIEW

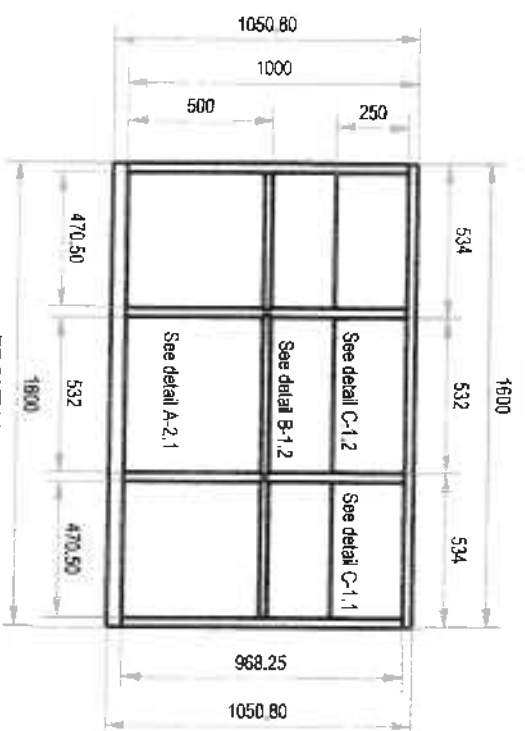

FRONT VIEW

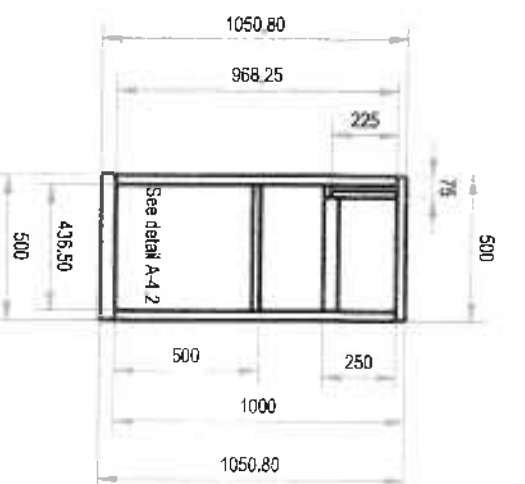

RIGHT SIDE VIEW

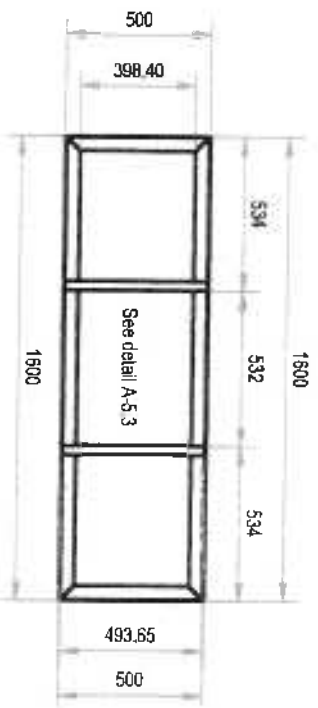

BOTTOM VIEW

**MTL BOX NO. 3 FRAME
 (BREAD AND PASTRY)**
 (The door is not shown in the drawing)

| | | |
|---|---------------|---------------------------------------|
|  <p>TECHNICAL EDUCATION AND SKILLS DEVELOPMENT AUTHORITY</p> | PROJECT TITLE | <p>MOBILE TRAINING LABORATORY</p> |
| | DRAWN BY: JVA | |
| <p>78</p> | | <p>1/</p> |

DETAIL A-1.1:

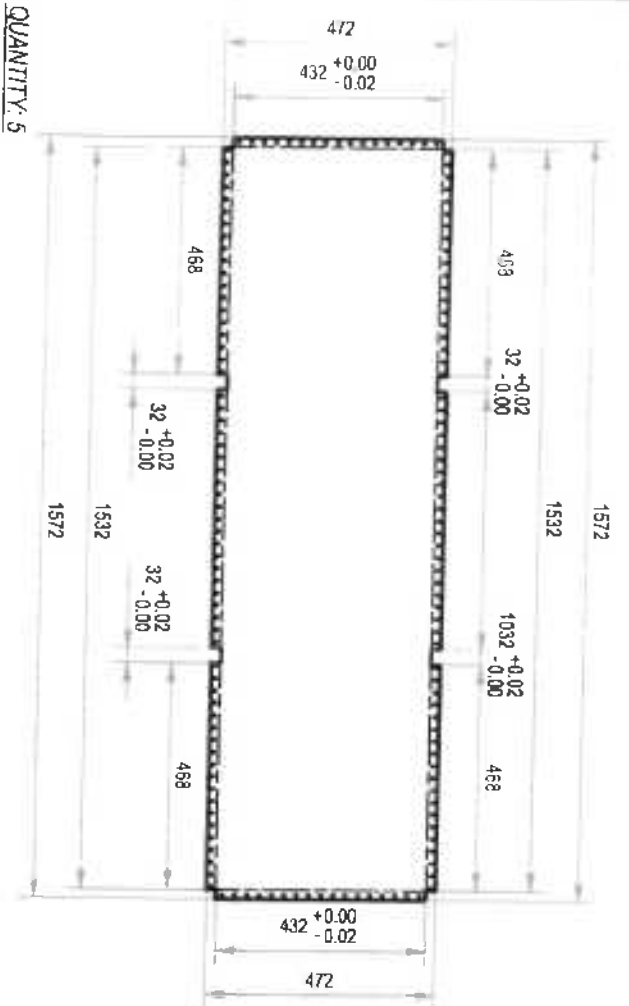

QUANTITY: 5

DETAIL A-1.2:

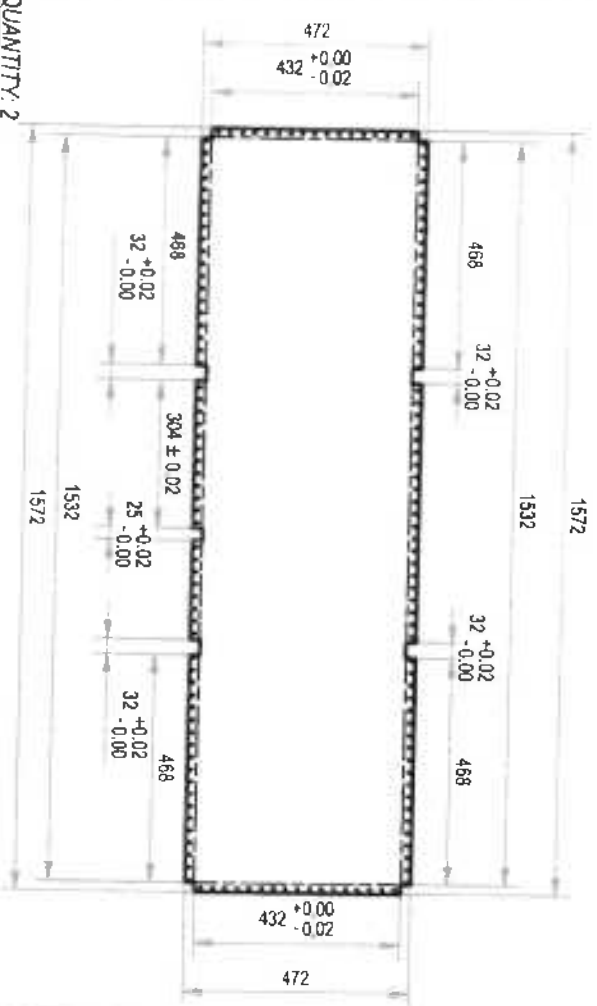

QUANTITY: 2

DETAIL A-1.3:

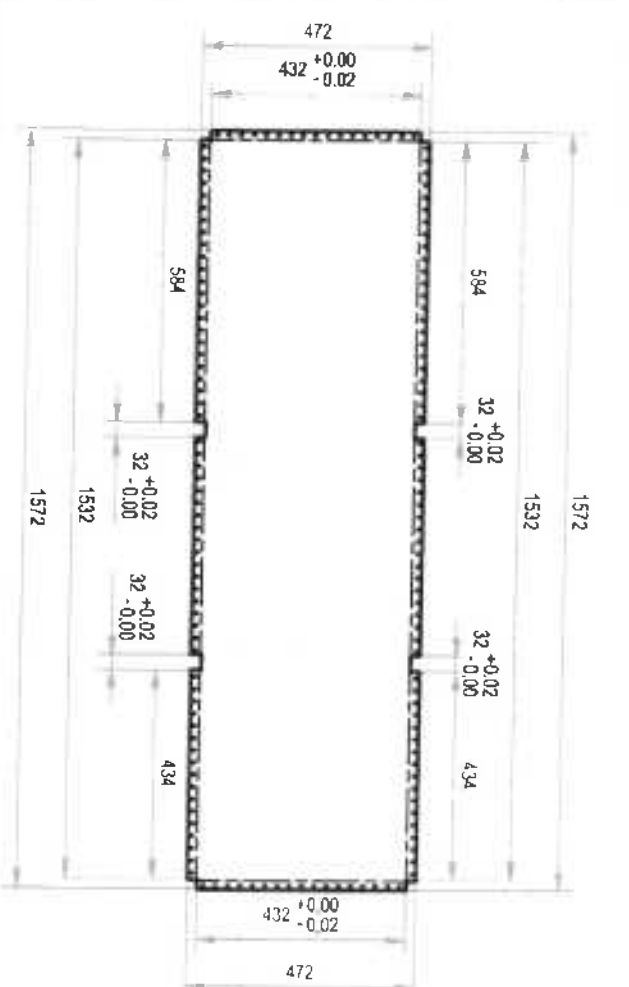

QUANTITY: 1

DETAIL A-1.4:

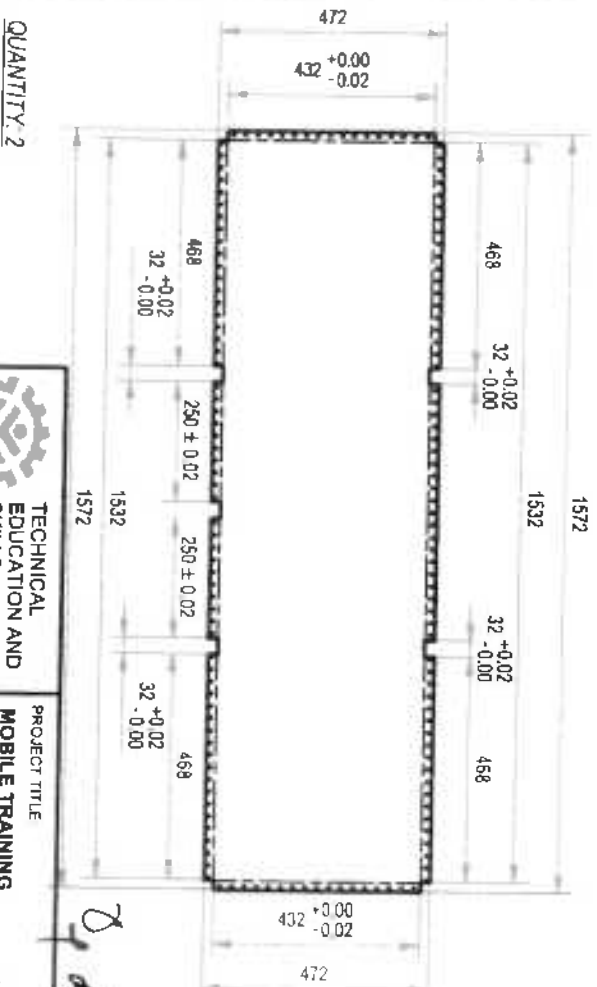

QUANTITY: 2

FLAT PATTERN: GALVANIZED SHEET GAUGE #18, PAINTED

Use 3/16" blind rivet spaced @ 1" O.C.



TECHNICAL EDUCATION AND SKILLS DEVELOPMENT AUTHORITY

PROJECT TITLE
MOBILE TRAINING LABORATORY

DRAWN BY: JPA

SCALE: 1:15

DATE: 11/11

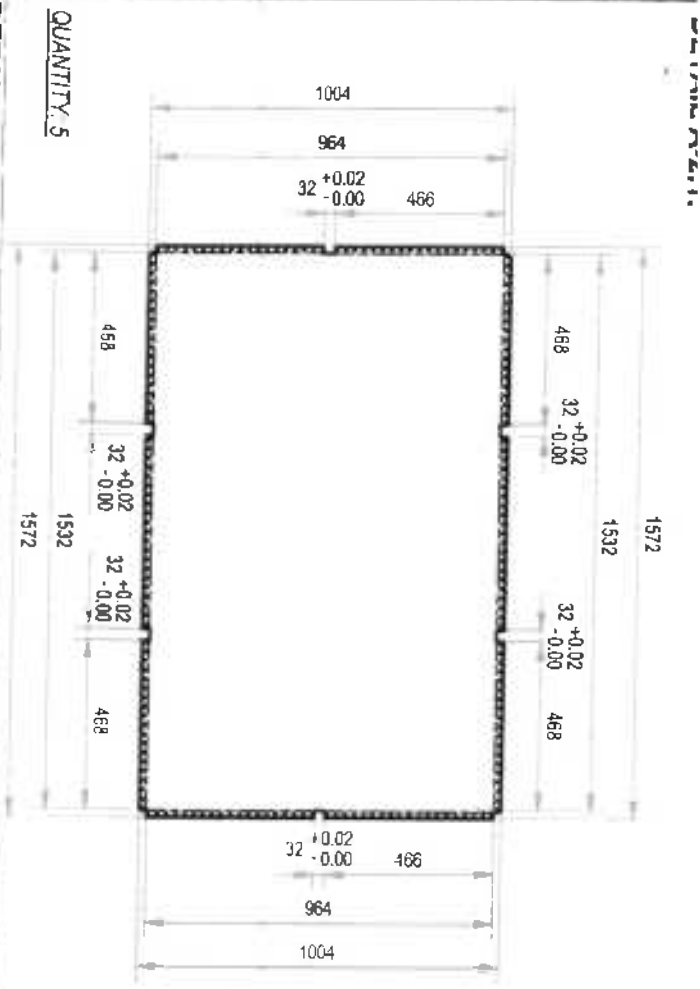

QUANTITY: 5

DETAIL A-2.2:

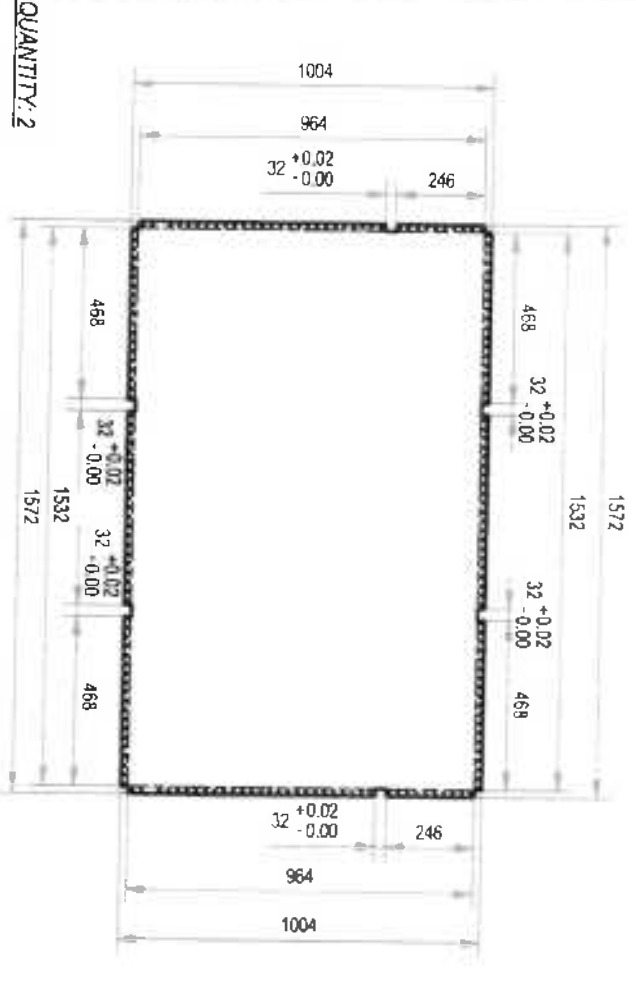

QUANTITY: 2

FLAT PATTERN: GALVANIZED SHEET GAUGE #18, PAINTED

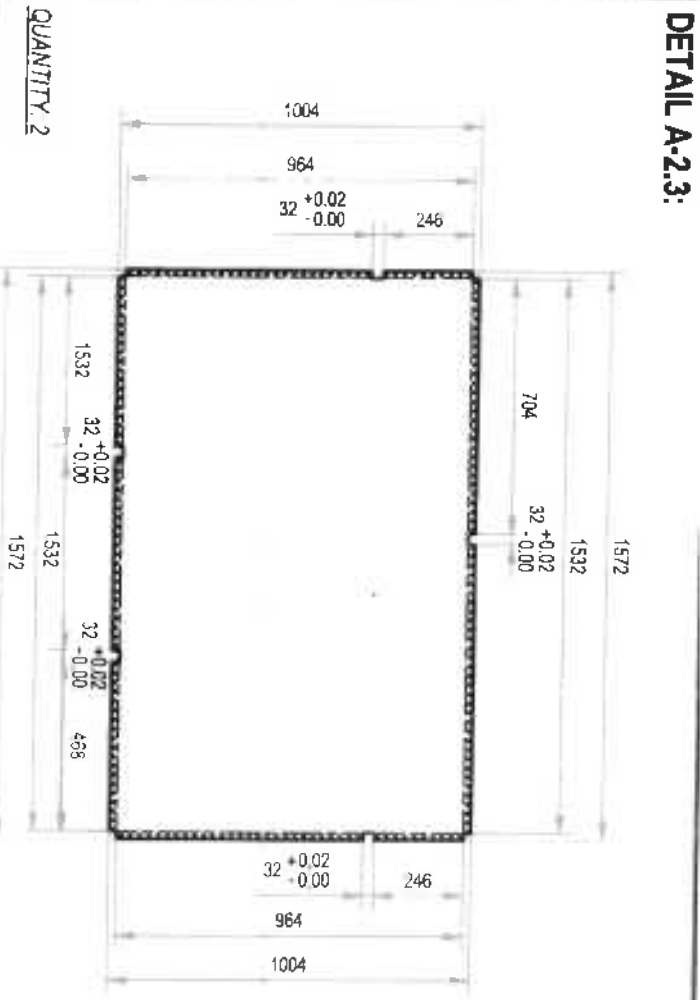

QUANTITY: 2

DETAIL A-2.4:

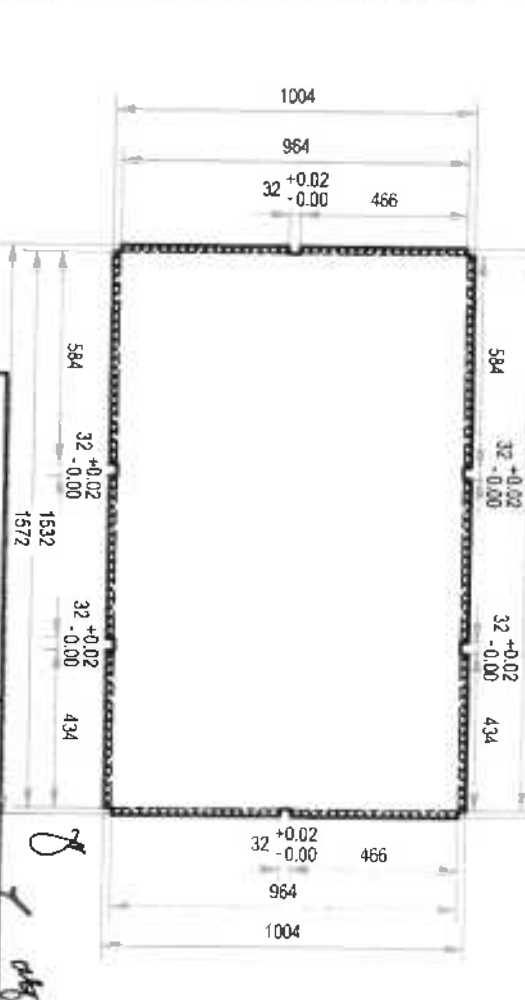

QUANTITY: 1

Use 3/6" blind rivet spaced @ 1" O.C.



TECHNICAL EDUCATION AND SKILLS DEVELOPMENT AUTHORITY

PROJECT TITLE
MOBILE TRAINING LABORATORY

DRAWN BY: JSA

Scale: 1:20

Sheet No. 1/

DETAIL A-3.1:

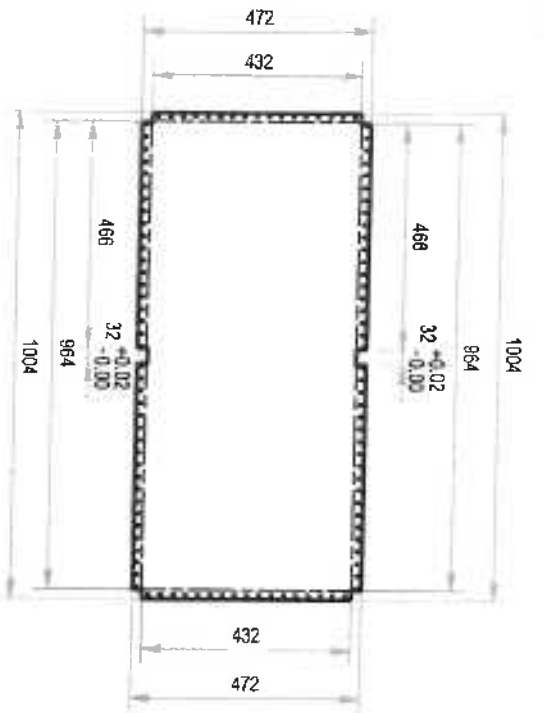

QUANTITY: 5

DETAIL A-3.3:

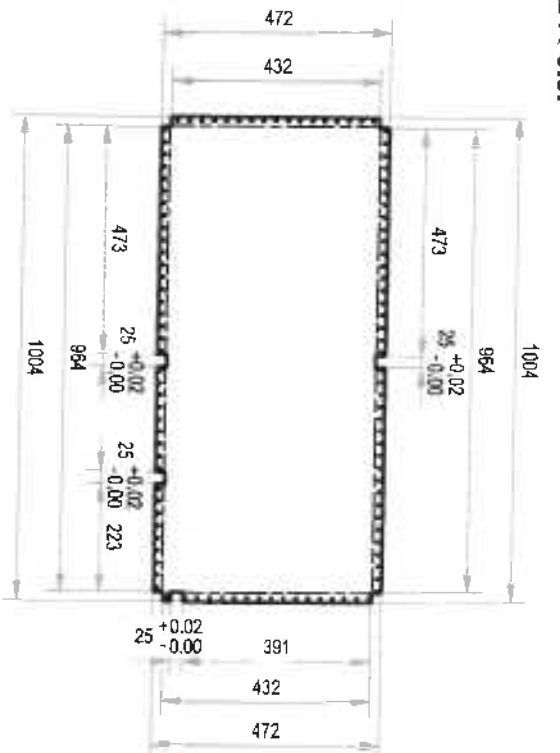

QUANTITY: 1

DETAIL A-3.4:

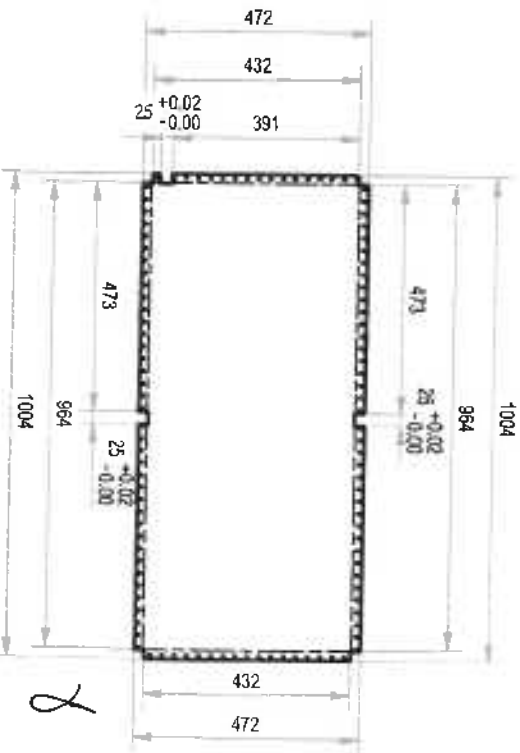

QUANTITY: 2

QUANTITY: 4

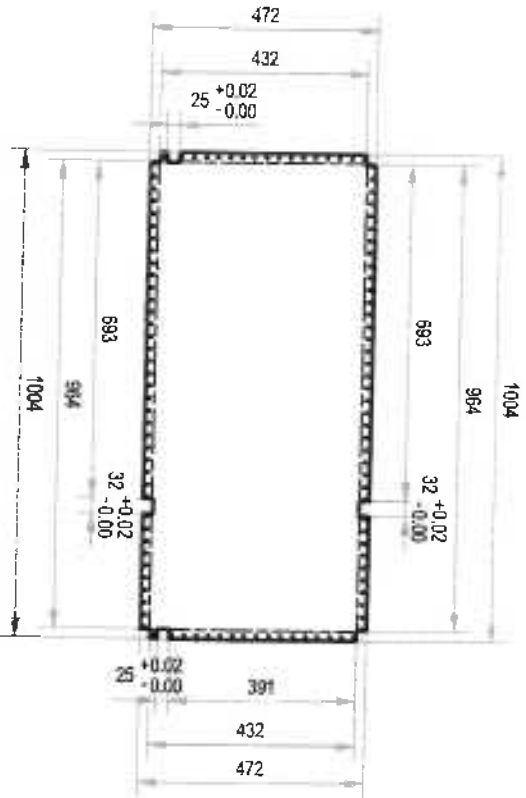

FLAT PATTERN- GALVANIZED SHEET GAUGE #18, PAINTED

Use 3/16" blind rivet spaced @ 1" O.C.



TECHNICAL EDUCATION AND SKILLS DEVELOPMENT AUTHORITY

PROJECT TITLE
MOBILE TRAINING LABORATORY

Sheet No. 1/1

DRAWN BY: JAM

Scale: 1:15

Sheet No. 1/1

DETAIL A-4.1:

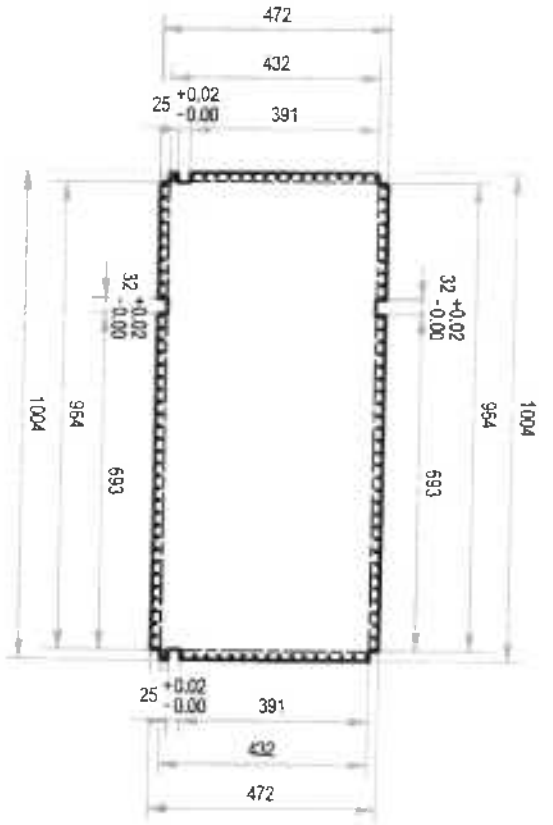

QUANTITY: 4

DETAIL A-4.2:

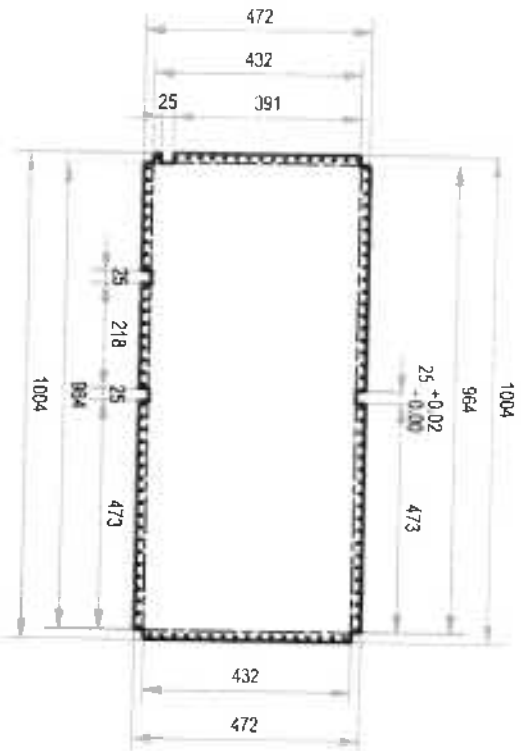

QUANTITY: 2

DETAIL A-4.3:

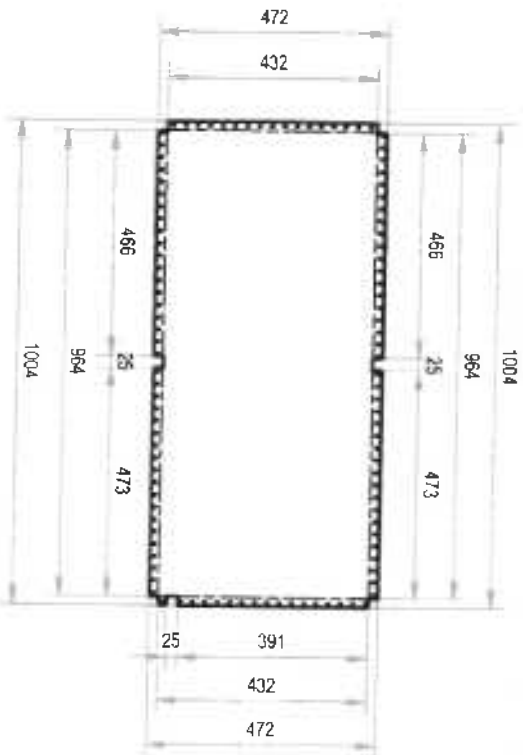

QUANTITY: 2

FLAT PATTERN: GALVANIZED SHEET GAUGE #18, PAINTED

Use 3/16" blind rivet spaced @ 1' O.C.



TECHNICAL EDUCATION AND SKILLS DEVELOPMENT AUTHORITY

PROJECT TITLE
MOBILE TRAINING LABORATORY

Scale 1/1

Drawn by J.W.

Scale 1/15

Sheet No. 1/1

DETAIL A-5.1:

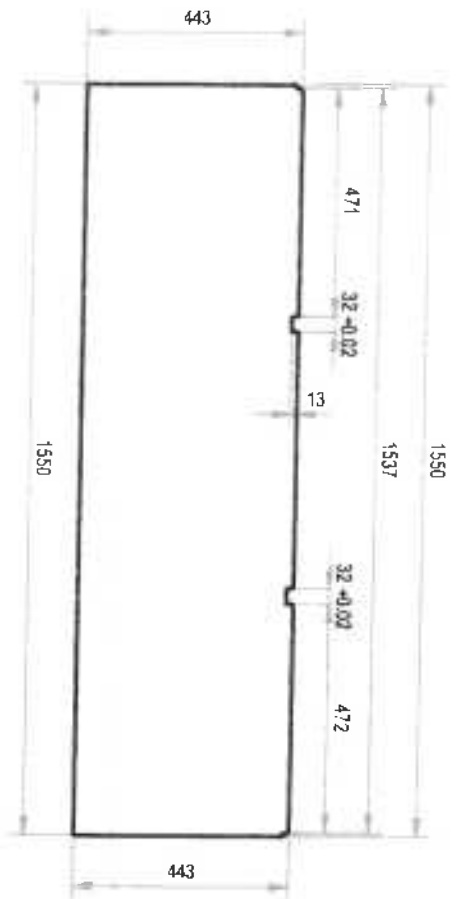

QUANTITY: 1

DETAIL A-5.3:

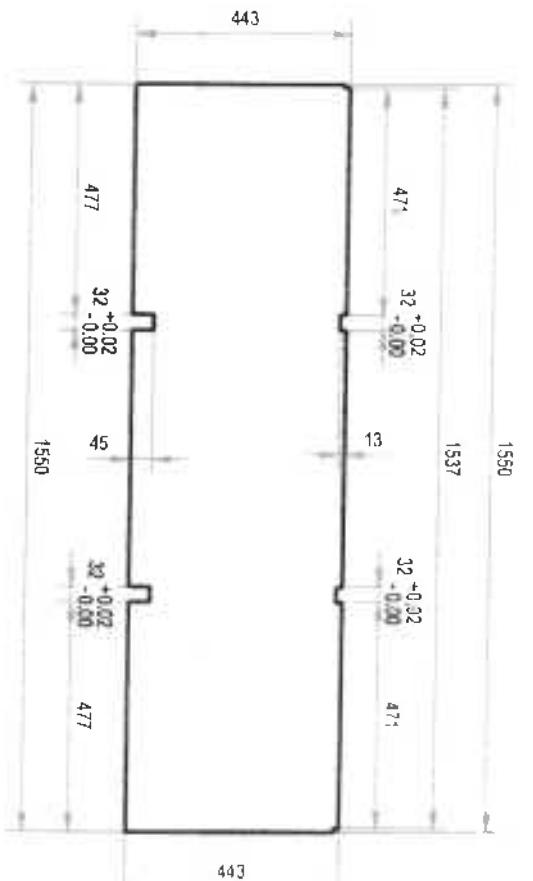

QUANTITY: 2

DETAIL A-5.2:

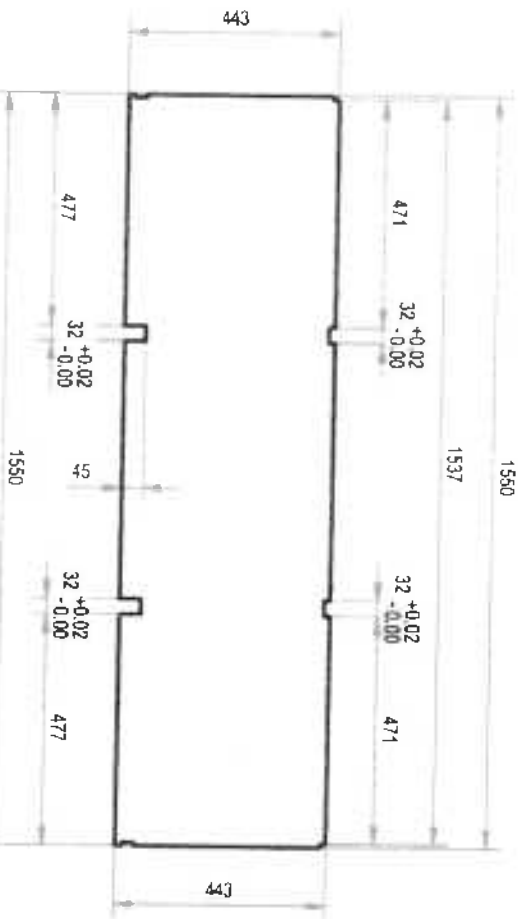

QUANTITY: 6

DETAIL A-5.4:

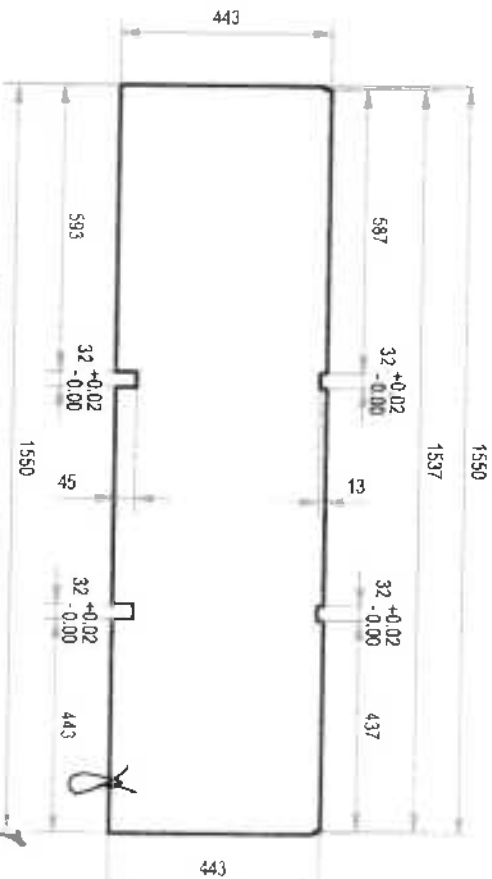

QUANTITY: 1

GALVANIZED SHEET GAUGE #18, PAINTED

PRODUCED BY AN AUTODESK EDUCATIONAL PRODUCT



TECHNICAL EDUCATION AND SKILLS DEVELOPMENT AUTHORITY

PROJECT TITLE
MOBILE TRAINING LABORATORY

Drawn By: JPM

Scale: 1:15

Sheet No. 1/1

DETAIL B-1.1:

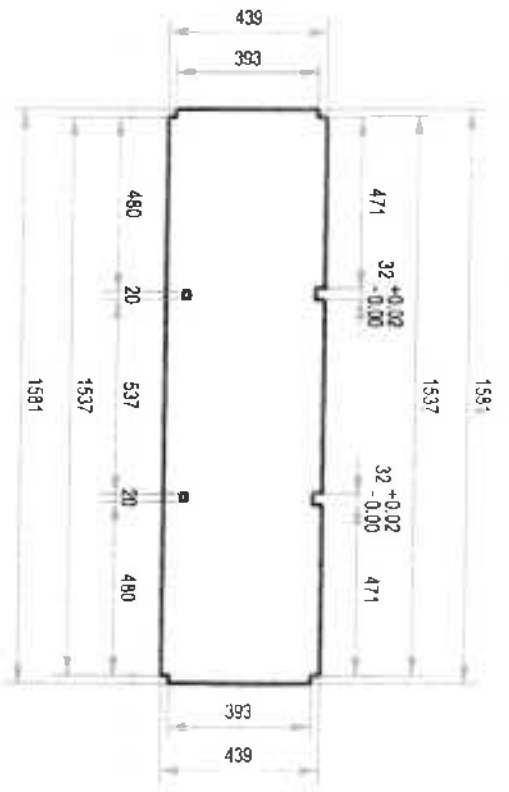

QUANTITY: 2

DETAIL B-1.2:

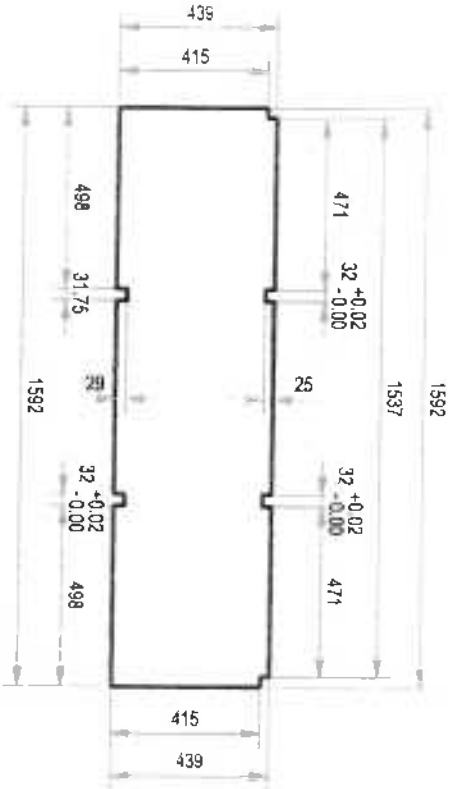

QUANTITY: 1

GALVANIZED SHEET GAUGE #18, PAINTED

DETAIL B-1.3:

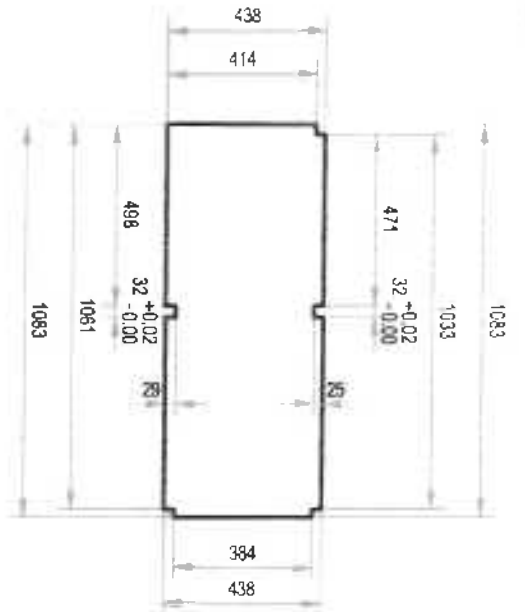

QUANTITY: 1

DETAIL B-1.4:

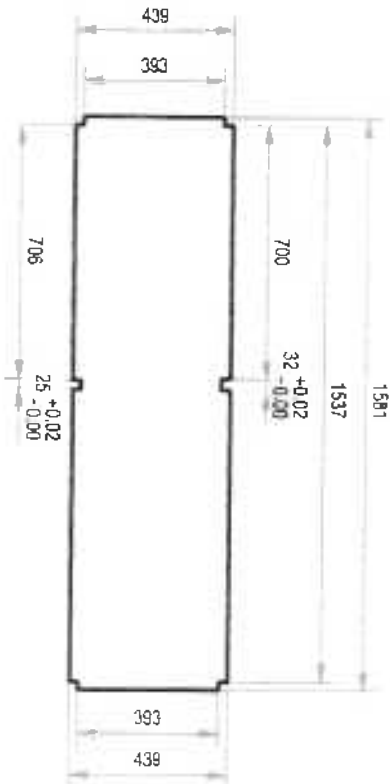

QUANTITY: 2

PRODUCED BY AN AUTODESK EDUCATIONAL PRODUCT



TECHNICAL
EDUCATION AND
SKILLS
DEVELOPMENT
AUTHORITY

PROJECT TITLE
MOBILE TRAINING
LABORATORY

M

Drawn by

Scale 1:20

Sheet No.

1/1

Handwritten notes: B, 1, 2, 3, 4

DETAIL C-1.1:

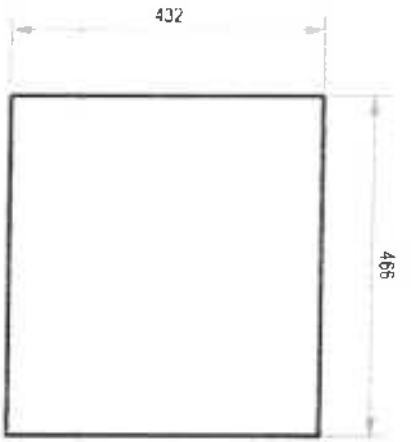

QUANTITY: 15

DETAIL C-1.2:

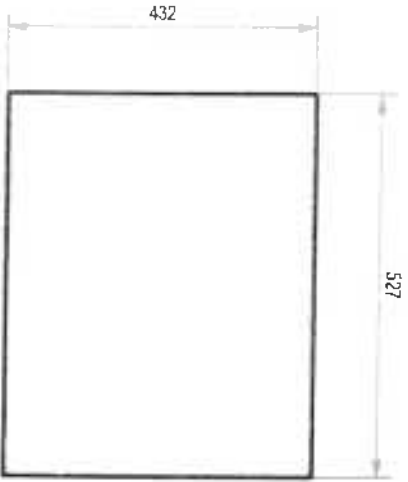

QUANTITY: 9

GALVANIZED SHEET GAUGE #18, PAINTED

DETAIL C-1.3:

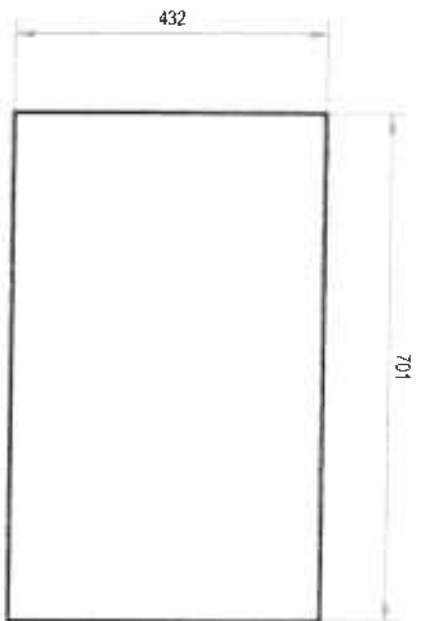

QUANTITY: 2

DETAIL D-1.1:

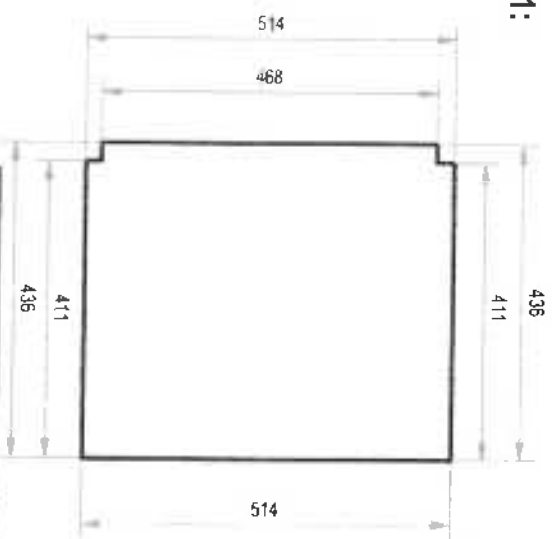

QUANTITY: 1

PRODUCED BY AN AUTODESK EDUCATIONAL PRODUCT



TECHNICAL EDUCATION AND SKILLS DEVELOPMENT AUTHORITY

PROJECT TITLE
MOBILE TRAINING LABORATORY

N

Drawn by: J.A.

Scale: 1:10

Sheet No: 1/1

Handwritten notes:
 2
 1
 2019

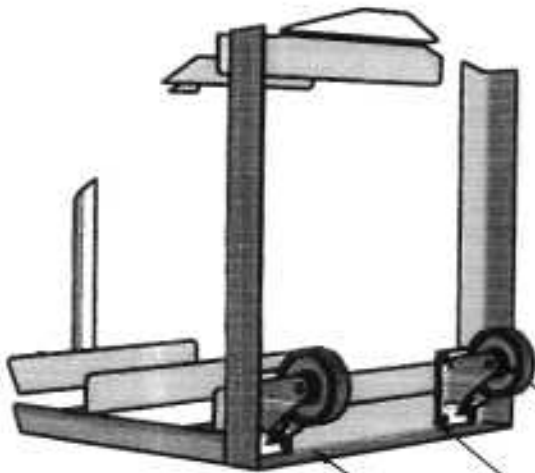

A (1 : 10)

4 pcs. of 4" polyurethane roller wheels with top plate bearing and self-locking; load capacity: 125 lbs. per wheel

Welded in 4" x 4" x 5 mm metal plate

2" x 2" x 3/16" \angle bar, painted



TECHNICAL
EDUCATION AND
SKILLS
DEVELOPMENT
AUTHORITY

PROJECT TITLE
MOBILE TRAINING
LABORATORY

AW

DRAWN BY J/A

Scale 1:20

Sheet No. 1/

Handwritten signature and initials

DETAIL F: RUBBER DOOR SEAL

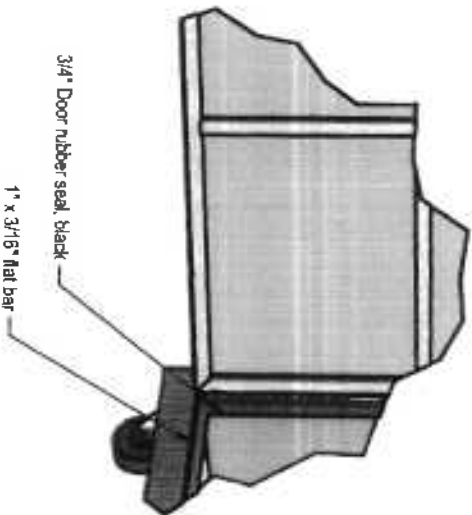
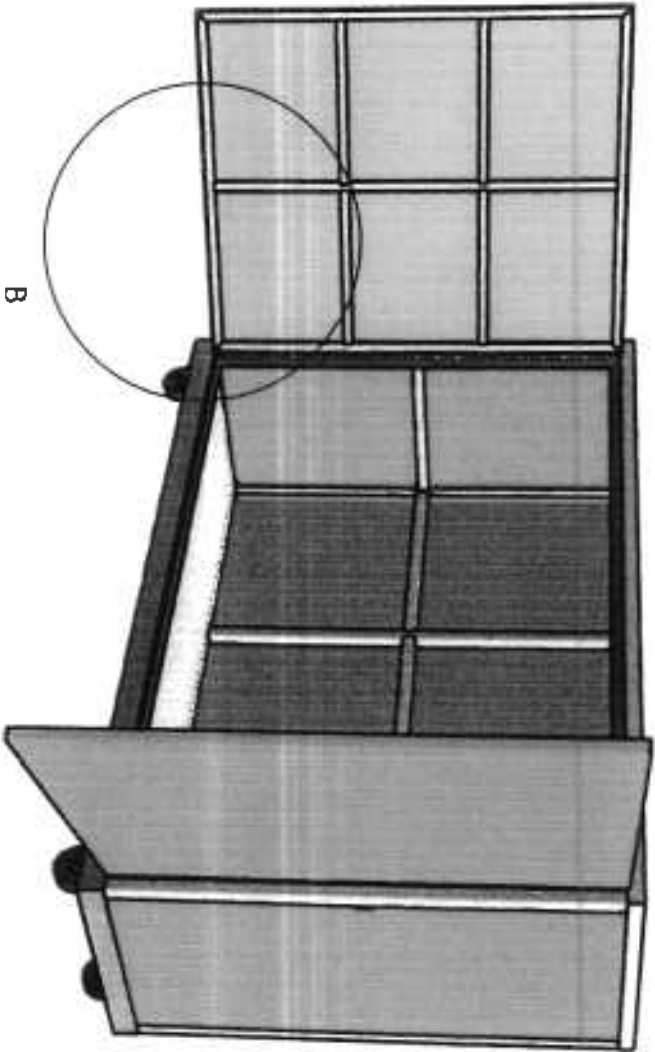

B (1:10)

| | | | | | |
|--|--|--|---|--|--|
| TECHNICAL EDUCATION AND SKILLS DEVELOPMENT AUTHORITY | | | PROJECT TITLE MOBILE TRAINING LABORATORY | | |
| DRAWN BY: JJA | | | Scale: 1/25 | | |
| 27 of 40 | | | SHEET NO.: 1 / | | |

| MTL BOX COVER FRAME, SIDEWAY SWING | | | |
|------------------------------------|------------------------------|-------------|-----|
| NO. | MATERIAL | LENGTH, mm | QTY |
| 1 | Gauge #18 G.I. sheet | 1,009 x 835 | 2 |
| 2 | 1" x 1" x 1.5 mm square tube | 968.25 | 4 |
| 3 | 1" x 1" x 1.5 mm square tube | 928.25 | 2 |
| 4 | 1" x 1" x 1.5 mm square tube | 793.65 | 4 |
| 5 | 1" x 1" x 1.5 mm square tube | 369.825 | 8 |
| 6 | 2" x 2mm piano hinge | 968 | 2 |
| TOTAL | | | 22 |

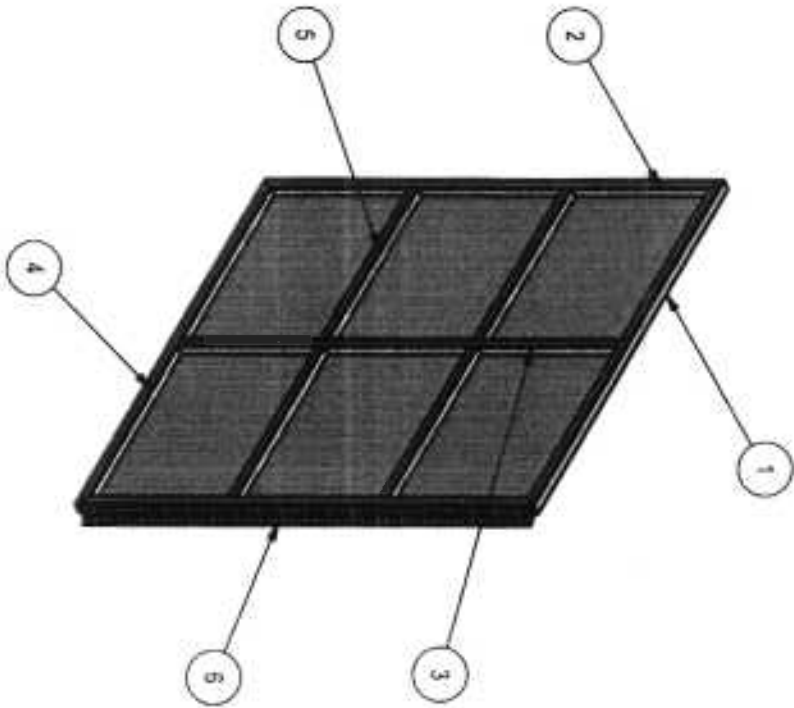

MTL DOOR FRAME

| | | |
|--|--|---|
| | TECHNICAL EDUCATION AND SKILLS DEVELOPMENT AUTHORITY | |
| | PROJECT TITLE MOBILE TRAINING LABORATORY | DRAWN BY: JKA Scale: 1/15 Author: N 1/ |

87 obj

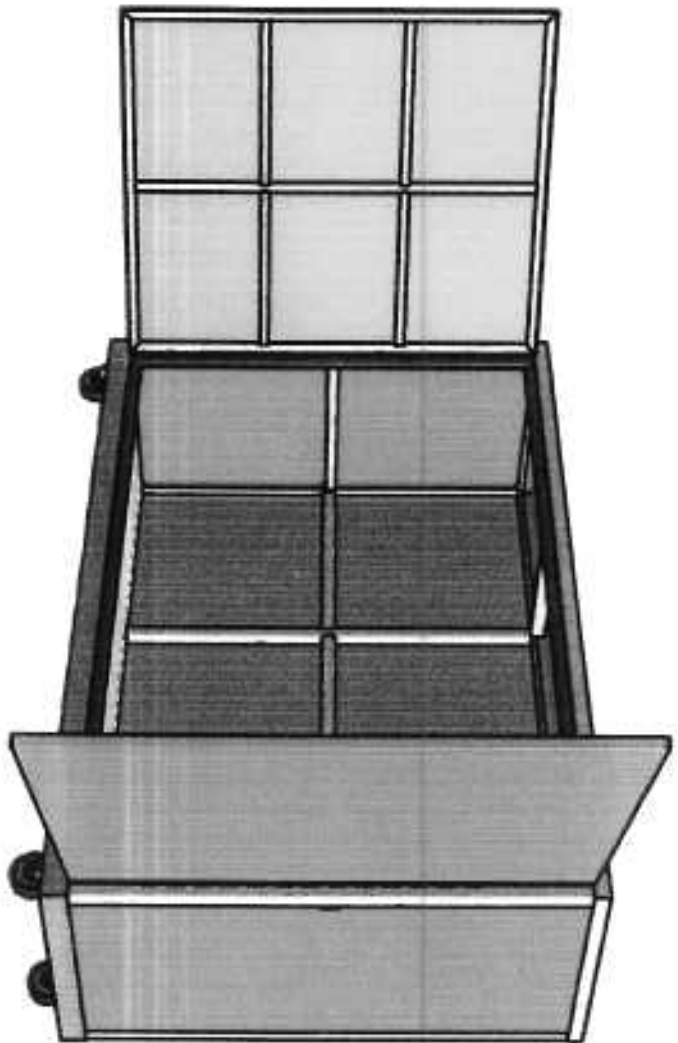

Include 2-sides metal handle
and lock with padlock for the
door (not shown in the drawing)

8 1 of 1



TECHNICAL
EDUCATION AND
SKILLS
DEVELOPMENT
AUTHORITY

PROJECT TITLE
**MOBILE TRAINING
LABORATORY**

NI

DRAWN BY: JPA

Scale: 1:15

Sheet No.:
1 /

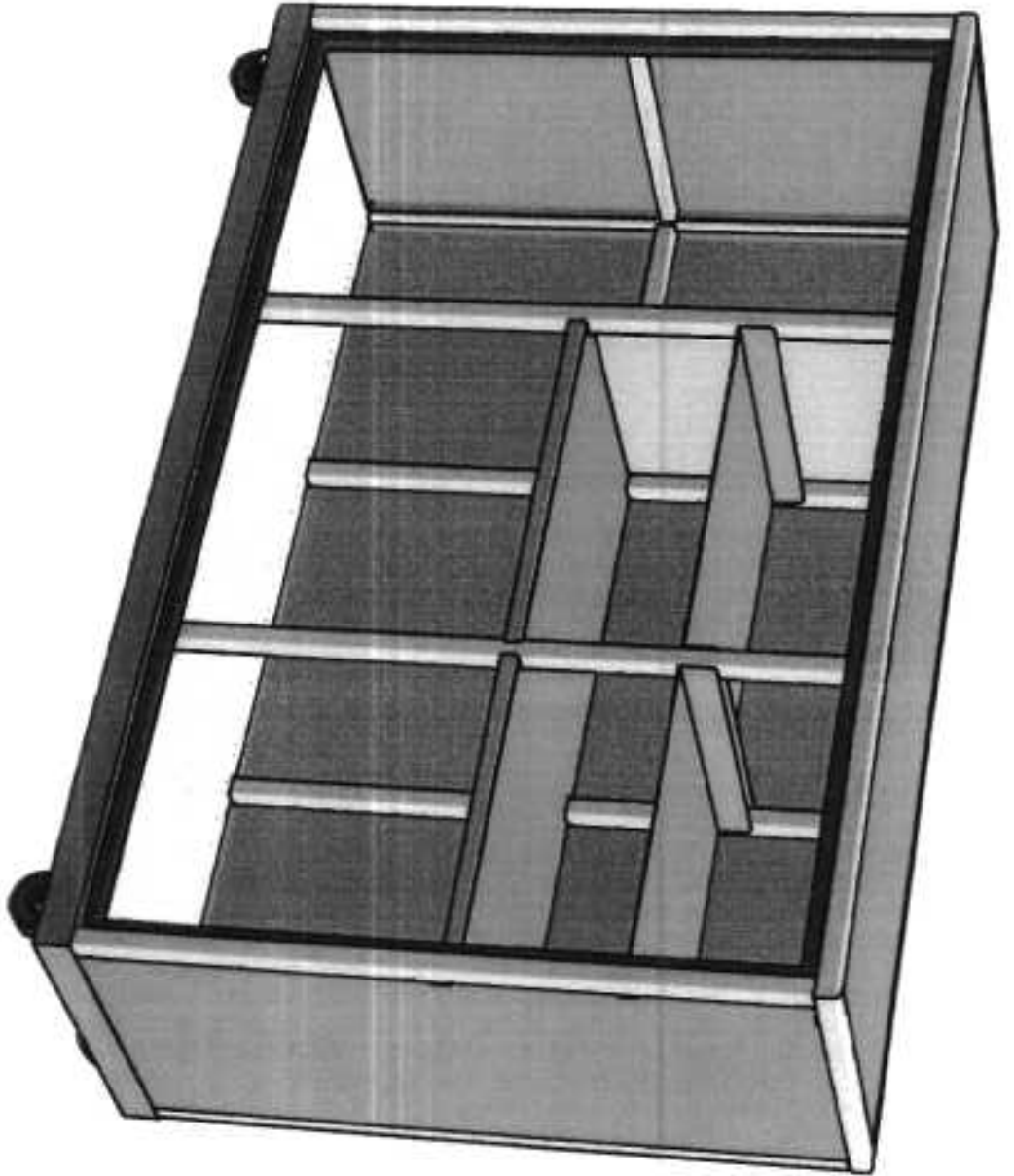

**MTL BOX NO. 4
(BREAD AND PASTRY)**
QUANTITY:
 (The door is not shown in the drawing)

PRODUCED BY AN AUTODESK EDUCATIONAL PRODUCT



TECHNICAL
 EDUCATION AND
 SKILLS
 DEVELOPMENT
 AUTHORITY

PROJECT TITLE
**MOBILE TRAINING
 LABORATORY**

N

Drawn by: JPA

Scale: 1:10

Sheet No. 1/1

Handwritten notes:
 27
 28
 parts

| MTL BOX 4 FRAME | | | |
|-----------------|---|------------|------|
| NO. | MATERIAL | LENGTH, mm | Qty. |
| 1 | 2" x 2" x 3/16" angle bar | 1,600.00 | 2 |
| 2 | 2" x 2" x 3/16" angle bar | 500.00 | 2 |
| 3 | 1 1/4" x 1 1/4" x 2 mm square tube | 493.65 | 2 |
| 4 | 1 1/4" x 1 1/4" x 2 mm square tube | 968.25 | 6 |
| 5 | 1 1/4" x 1 1/4" x 2 mm square tube | 1,600.00 | 2 |
| 6 | 1 1/4" x 1 1/4" x 2 mm square tube | 500.00 | 2 |
| 7 | 1 1/4" x 1 1/4" x 2 mm square tube | 436.50 | 2 |
| 8 | 1 1/4" x 1 1/4" x 2 mm square tube | 1,473.00 | 1 |
| 9 | 1 1/4" x 1 1/4" x 2 mm square tube | 971.80 | 2 |
| 10 | 1" x 1" x 1.5 mm square tube | 436.50 | 2 |
| 11 | 1" x 1" x 1.5 mm square tube | 385.29 | 2 |
| 12 | 1" x 1" x 1.5 mm square tube | 1,002.50 | 1 |
| 13 | 1" x 1" x 1.5 mm square tube | 43.25 | 1 |
| 14 | 1" x 1" x 1.5 mm square tube | 225.00 | 1 |
| 15 | Gauge #18 GI sheet, 2" x 2" @ 90 degrees bend | 431.70 | 6 |
| TOTAL | | | 34 |

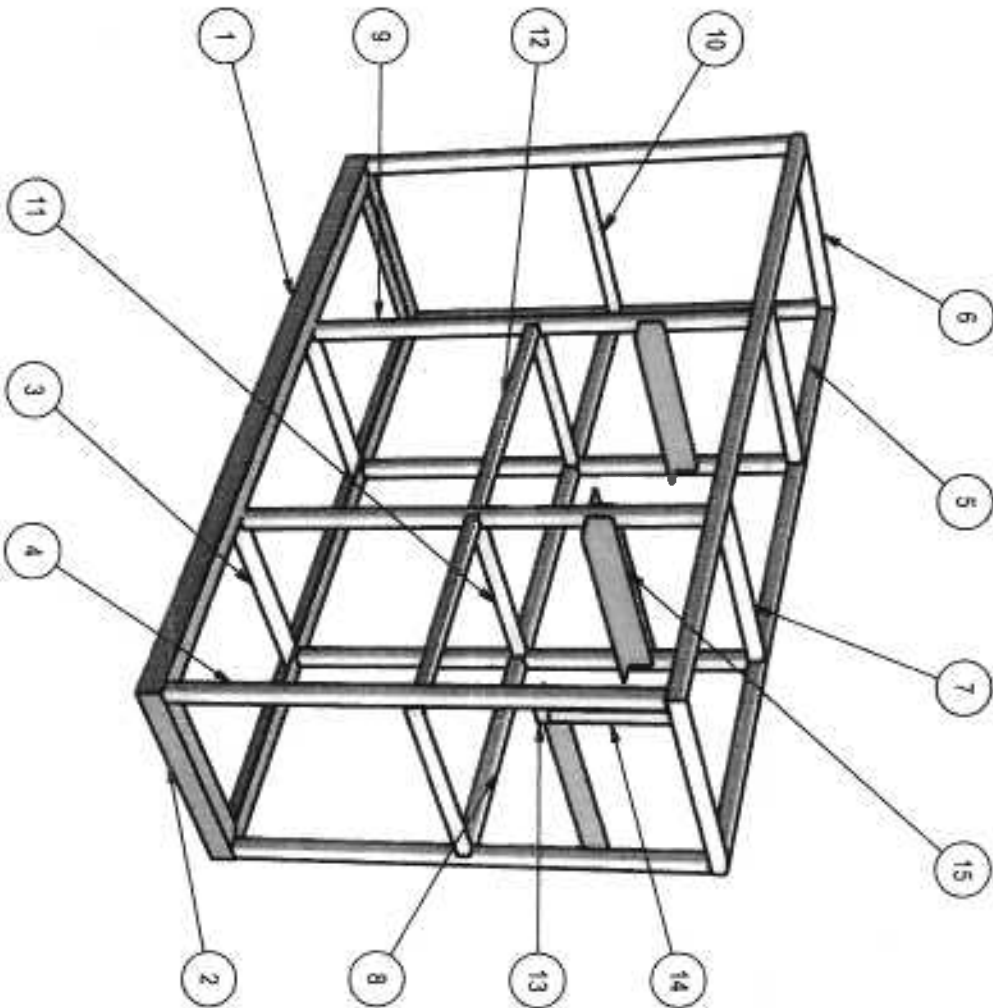

**MTL BOX NO. 4 FRAME
(BREAD AND PASTRY)**
(The door is not shown in the drawing)

PRODUCED BY AN AUTODESK EDUCATIONAL PRODUCT



TECHNICAL
EDUCATION AND
SKILLS
DEVELOPMENT
AUTHORITY

PROJECT TITLE
**MOBILE TRAINING
LABORATORY**

DRAWN BY: JAA

Scale: 1:15

Sheet No. 11

Handwritten notes: 8, 7, and a signature.

- MTL BOX NO. 4**
- ⊕ All materials must be painted with anti-corrosive primer
 - ⊕ □ tube end < bar are coated with light grey epoxy finish paint

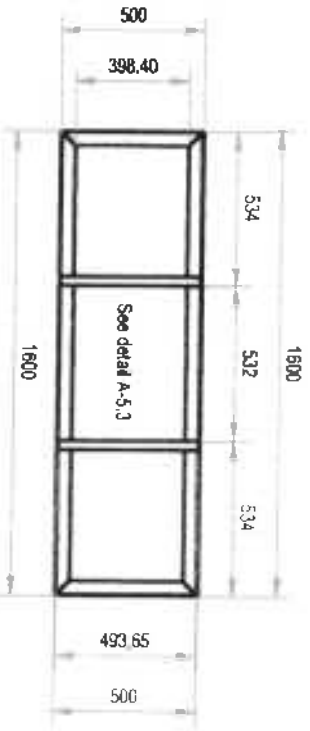
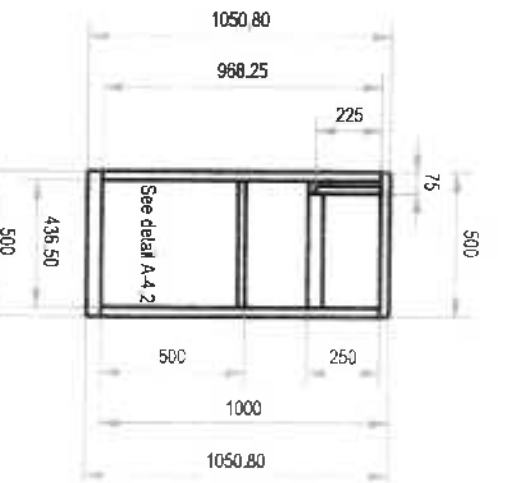
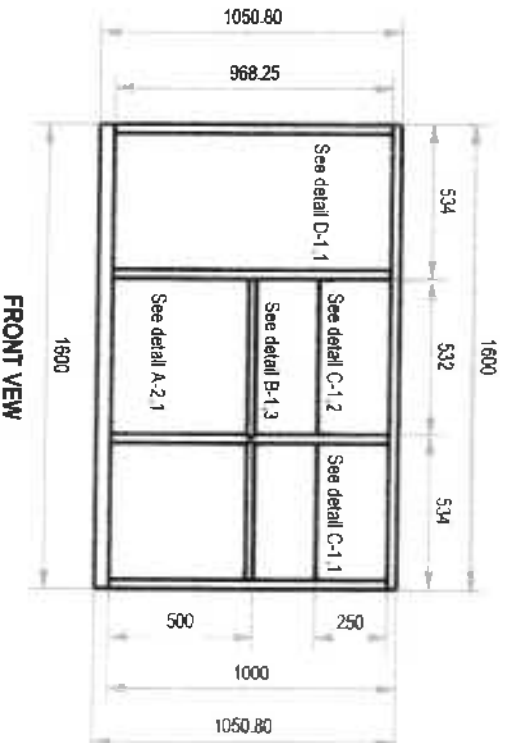
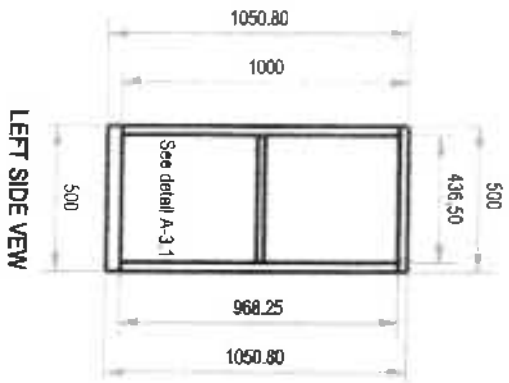
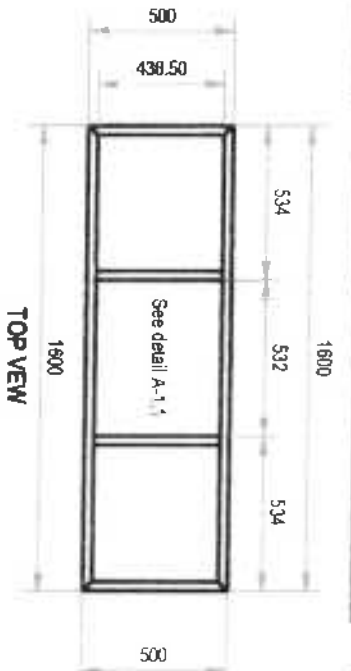

**MTL BOX NO. 4 FRAME
(BREAD AND PASTRY)**
(The door is not shown in the drawing)



TECHNICAL
EDUCATION AND
SKILLS
DEVELOPMENT
AUTHORITY

PROJECT TITLE
**MOBILE TRAINING
LABORATORY**

Scale: 1:25

DETAIL A-1.1:

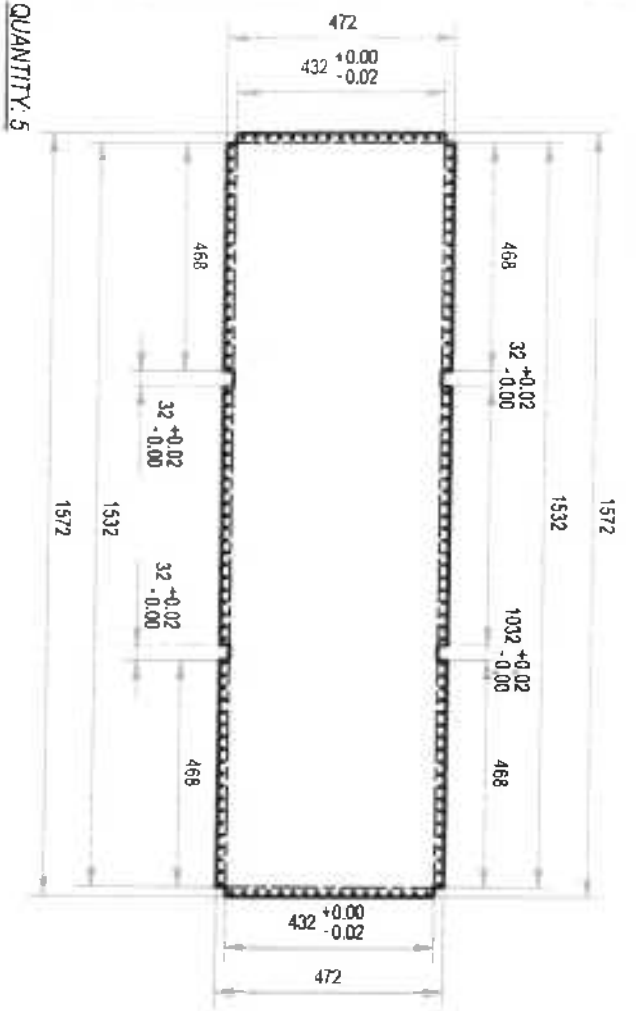

QUANTITY: 5

DETAIL A-1.3:

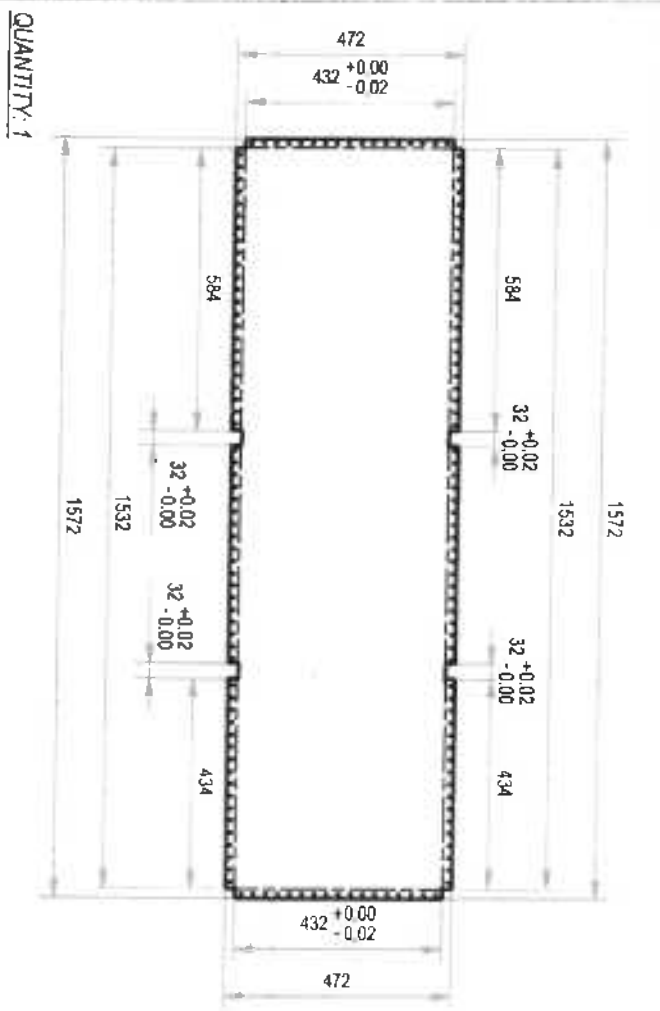

QUANTITY: 1

DETAIL A-1.2:

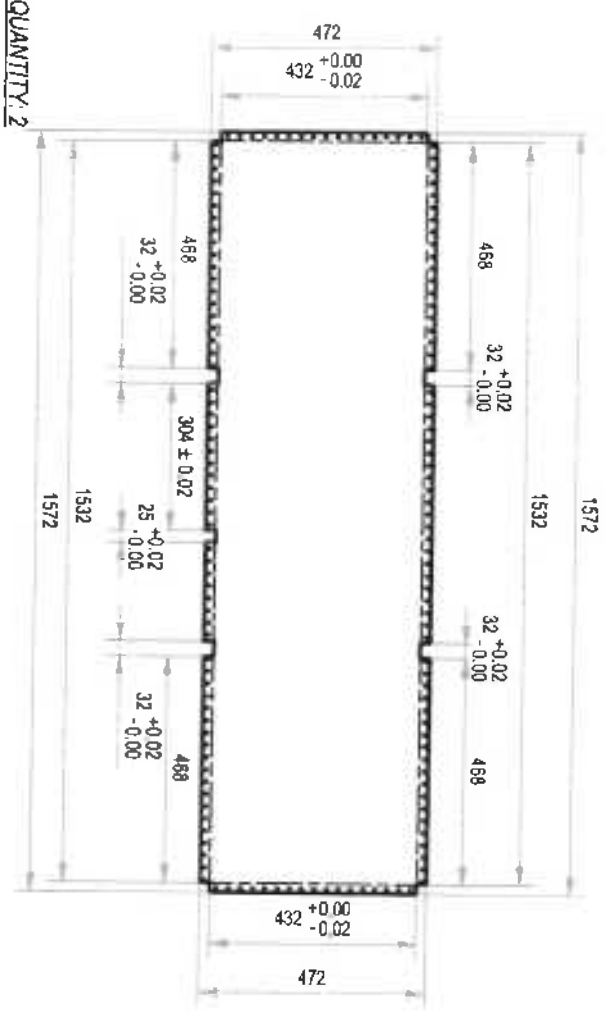

QUANTITY: 2

DETAIL A-1.4:

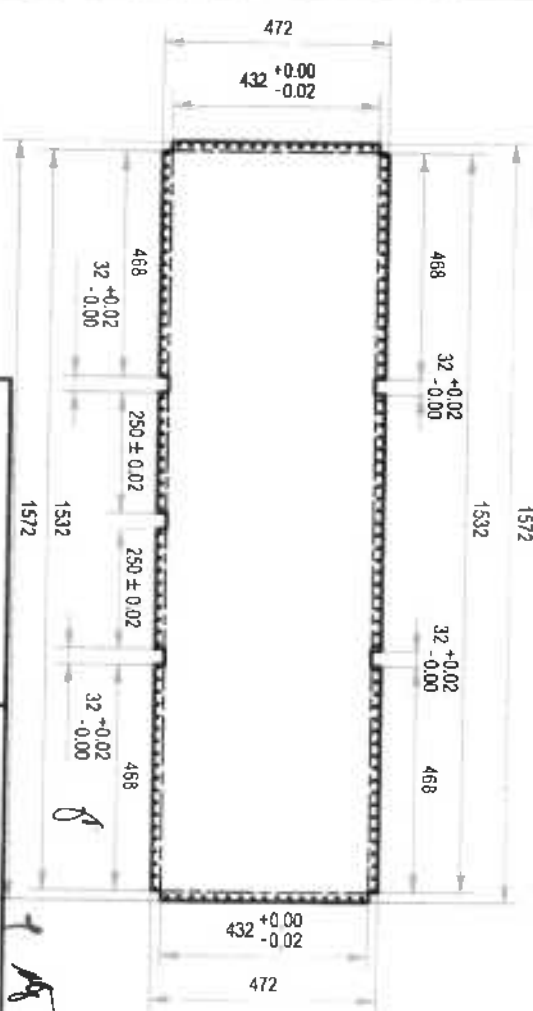

QUANTITY: 2

FLAT PATTERN: GALVANIZED SHEET GAUGE #18, PAINTED

Use 3/16" blind rivet spaced @ 1" O.C



PROJECT TITLE: MOBILE TRAINING LABORATORY
 DRAWN BY: JWA
 SCALE: 1:15
 SHEET NO: 1/1

PRODUCED BY AN AUTODESK EDUCATIONAL PRODUCT

DETAIL A-2.2:

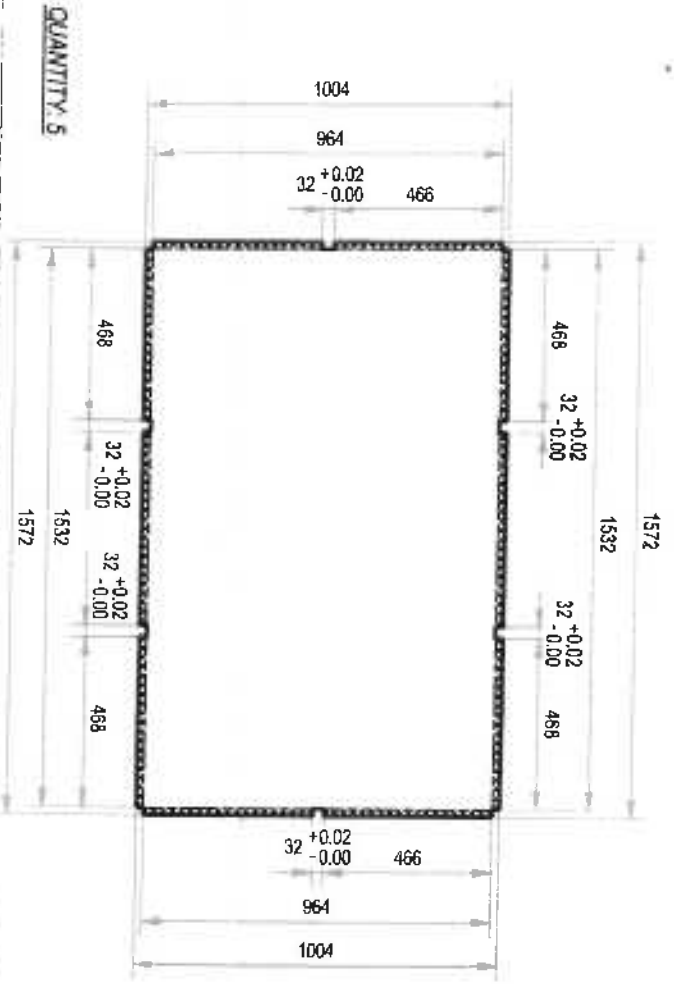

QUANTITY: 2

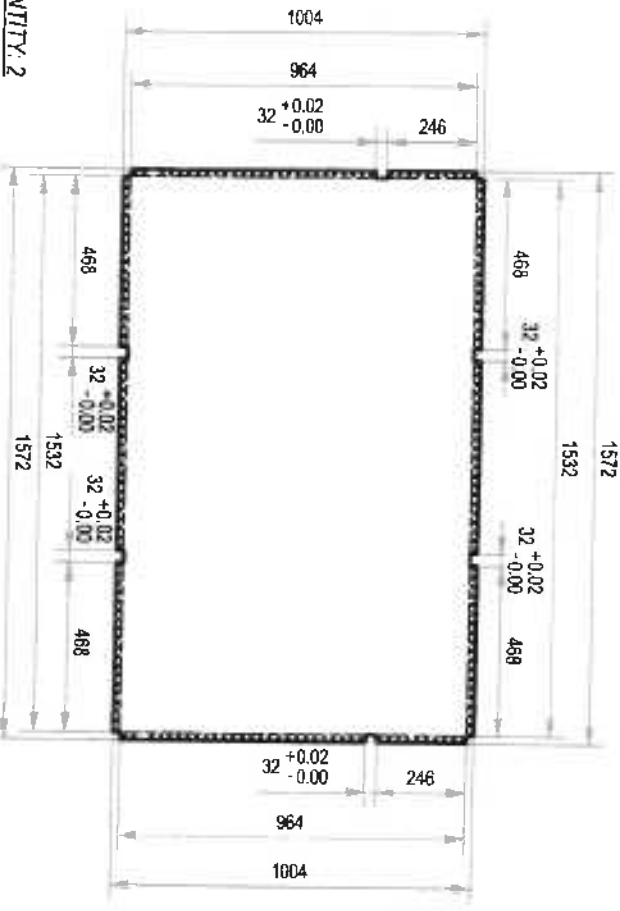

FLAT PATTERN: GALVANIZED SHEET GAUGE #18, PAINTED

DETAIL A-2.3:

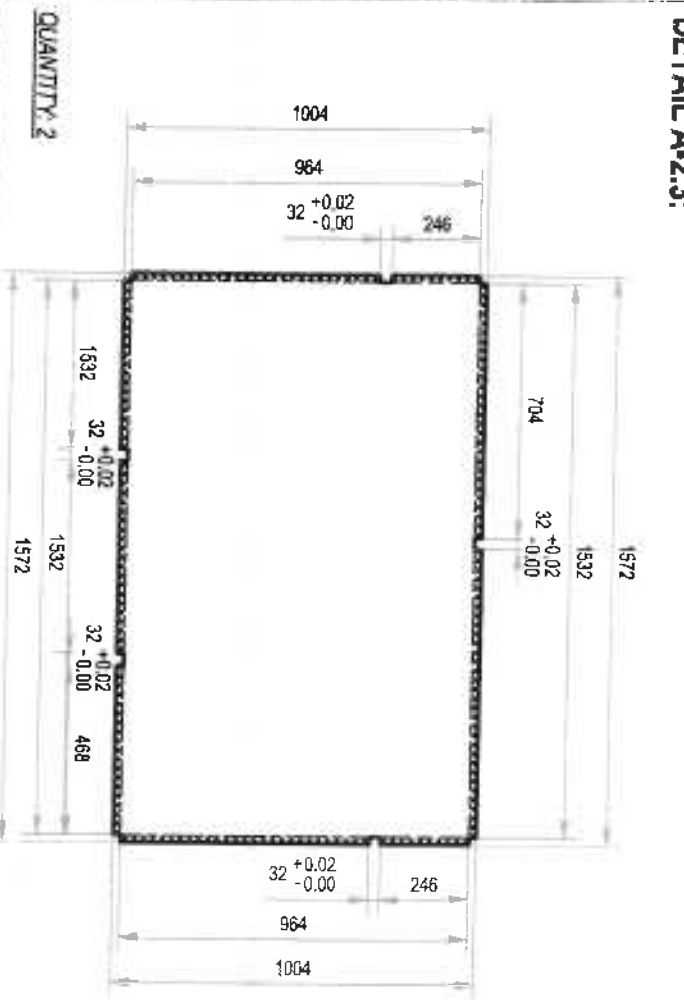

DETAIL A-2.4:

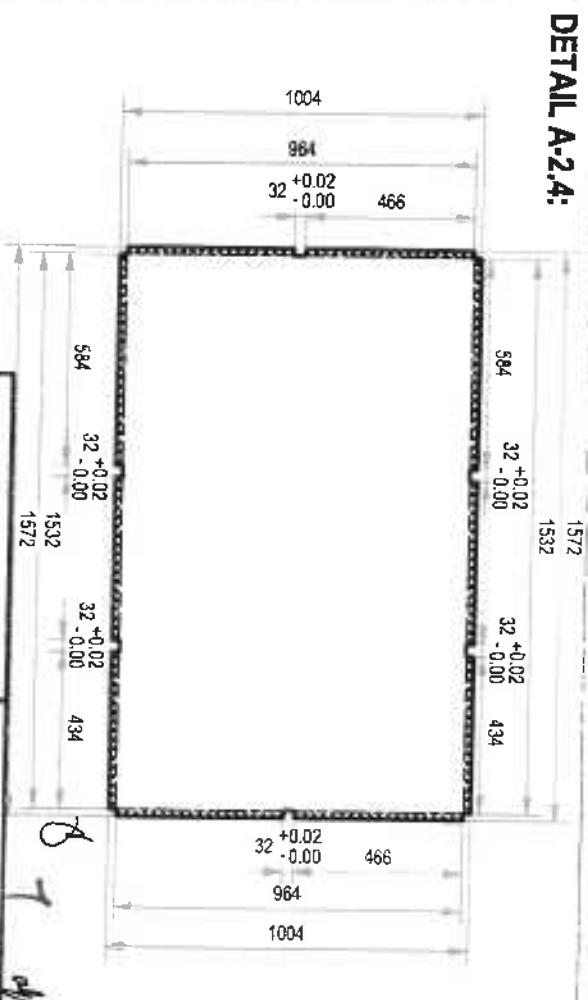

Use 3/8" blind rivet spaced @ 1" O.C.



TECHNICAL EDUCATION AND SKILLS DEVELOPMENT AUTHORITY

PROJECT TITLE
MOBILE TRAINING LABORATORY

DATE BY: JPA Scale: 1:20 Sheet No: 1 /

DETAIL A-3.1:

QUANTITY: 5

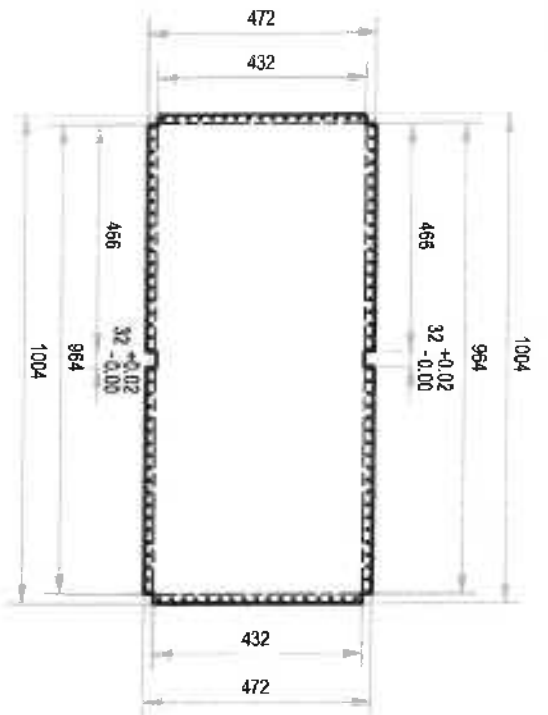

DETAIL A-3.3:

QUANTITY: 1

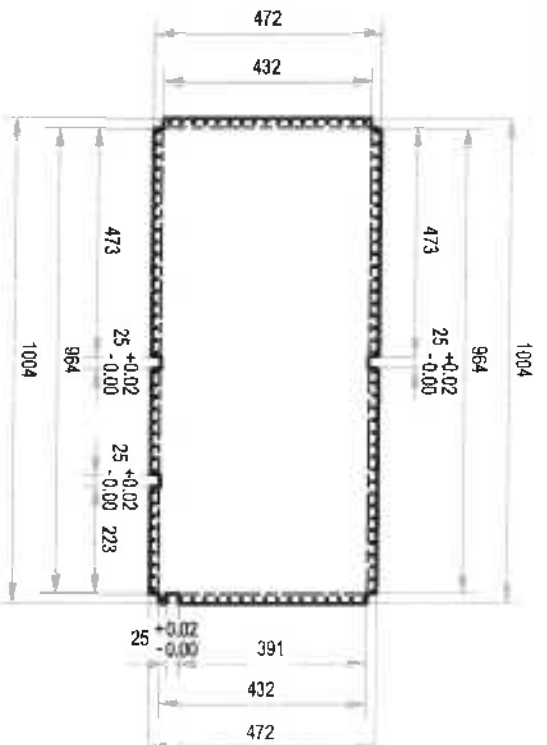

DETAIL A-3.2:

QUANTITY: 4

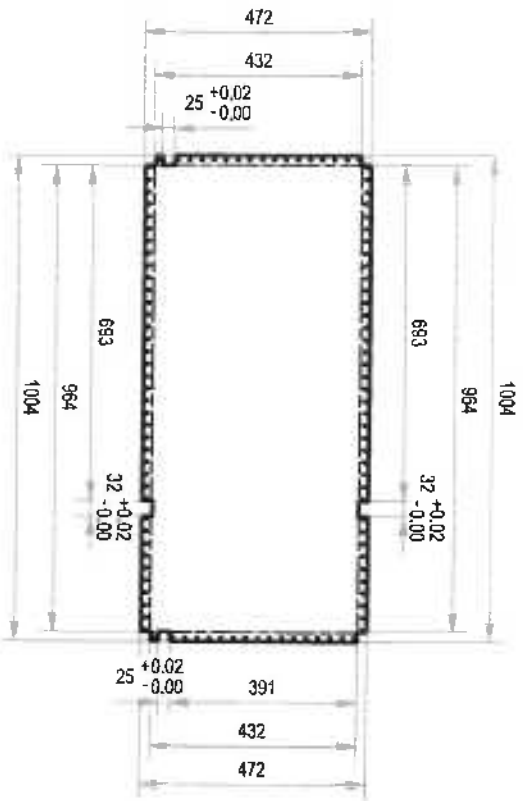

DETAIL A-3.4:

QUANTITY: 2

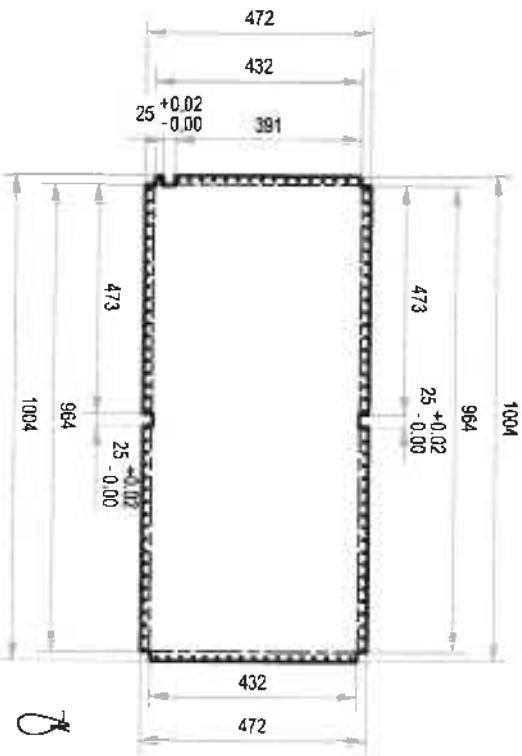

FLAT PATTERN: GALVANIZED SHEET GAUGE #18, PAINTED

Use 3/16" blind rivet spaced @ 1" O.C.



TECHNICAL
EDUCATION AND
SKILLS
DEVELOPMENT
AUTHORITY

PROJECT TITLE:
**MOBILE TRAINING
LABORATORY**

DRAWN BY: JSA

Scale: 1:15

Sheet No. 1 /

DETAIL A-4.1:

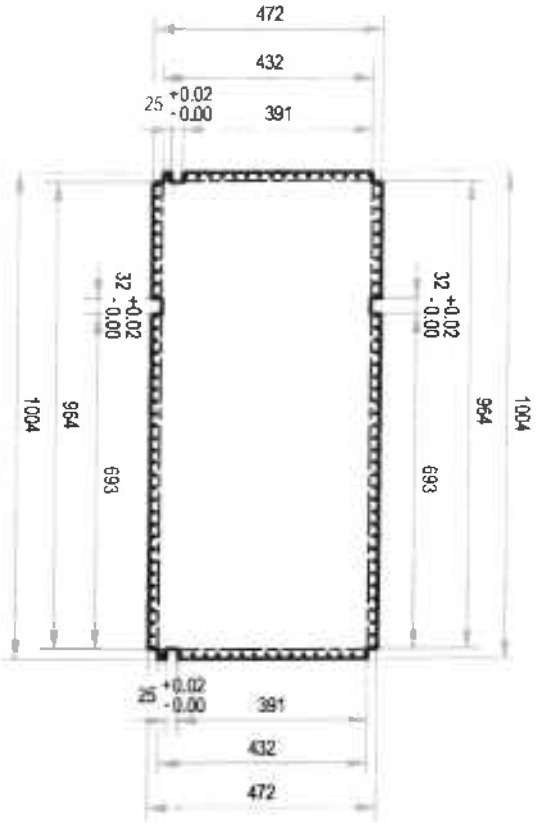

QUANTITY: 4

DETAIL A-4.2:

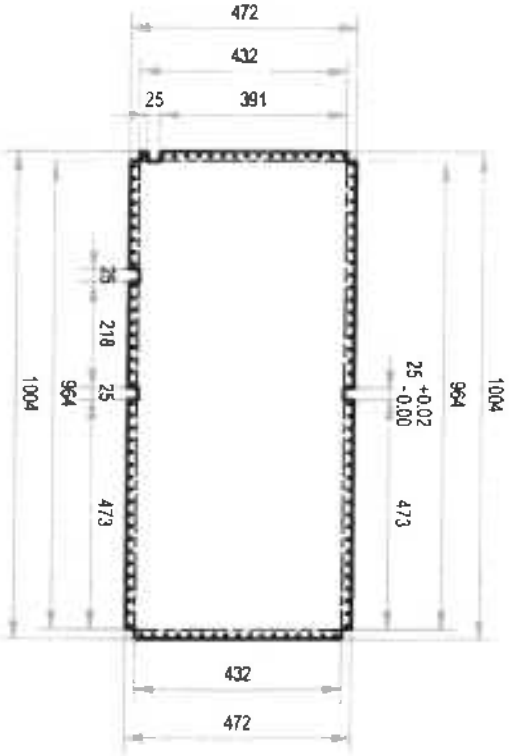

QUANTITY: 2

DETAIL A-4.3:

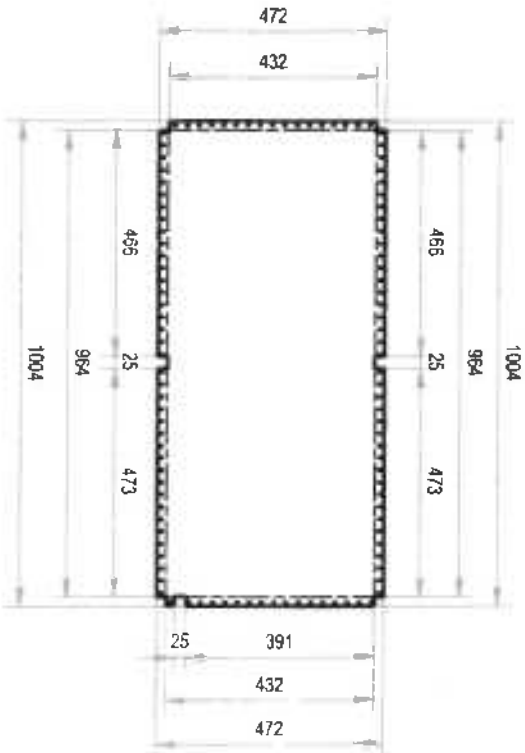

QUANTITY: 2

FLAT PATTERN: GALVANIZED SHEET GAUGE #18, PAINTED

Use 3/16" blind rivet spaced @ 1" O.C.



TECHNICAL EDUCATION AND SKILLS DEVELOPMENT AUTHORITY

PROJECT TITLE
MOBILE TRAINING LABORATORY

DATE: 07/2014

Scale: 1:15

Sheet No: 1/1

Handwritten initials and a checkmark.

DETAIL A-5.1:

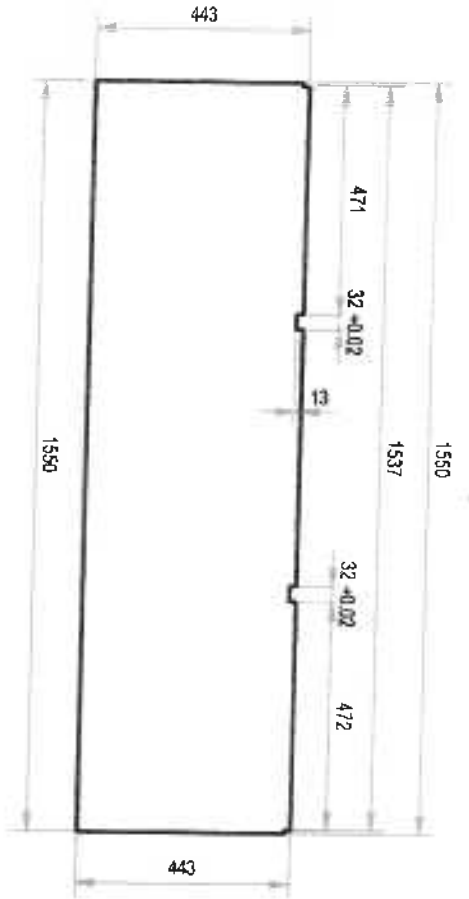

QUANTITY: 1

DETAIL A-5.2:

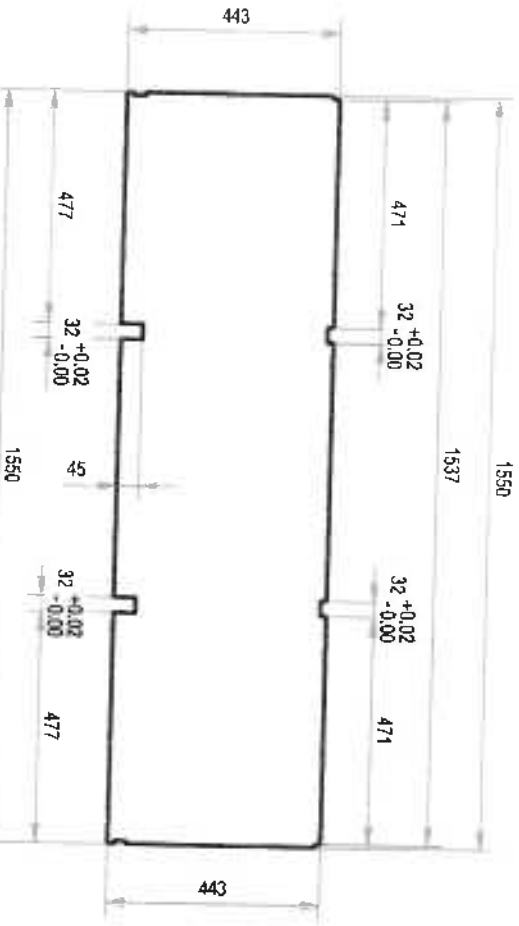

QUANTITY: 6

GALVANIZED SHEET GAUGE #18, PAINTED

PRODUCED BY AN AUTODESK EDUCATIONAL PRODUCT

DETAIL A-5.3:

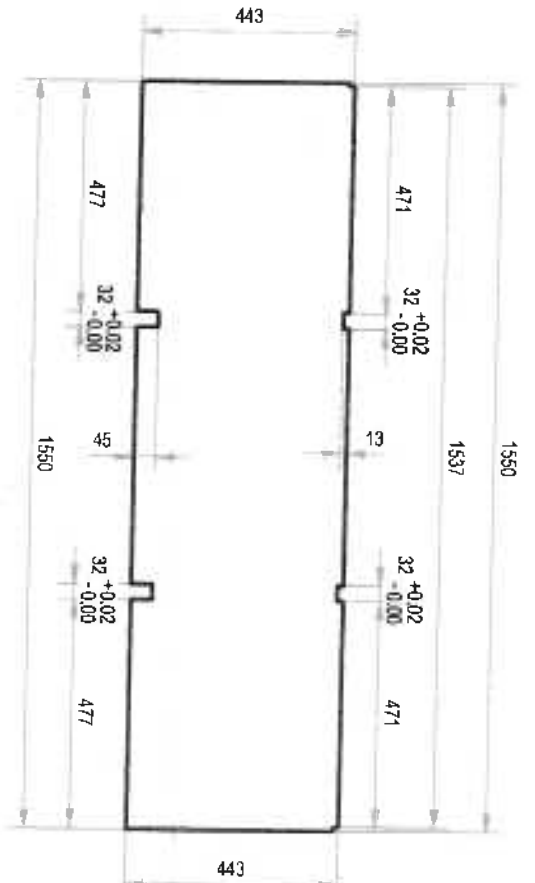

QUANTITY: 2

DETAIL A-5.4:

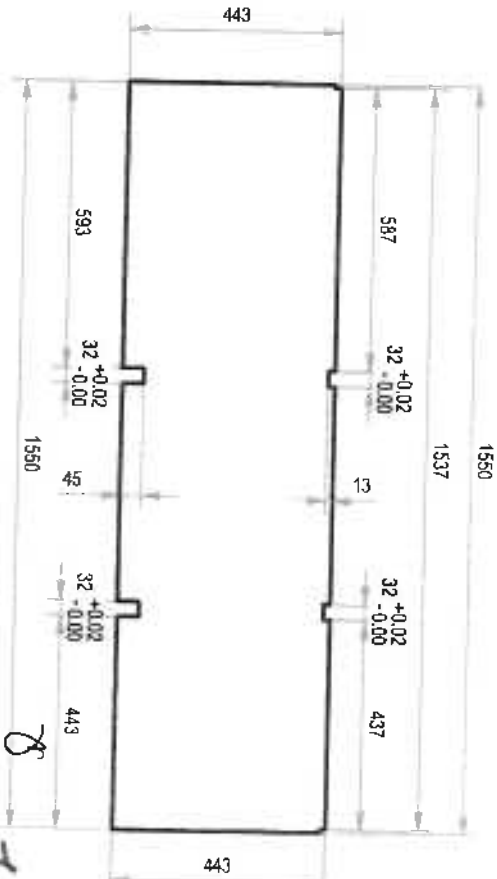

QUANTITY: 1



TECHNICAL
EDUCATION AND
SKILLS
DEVELOPMENT
AUTHORITY

PROJECT TITLE
**MOBILE TRAINING
LABORATORY**

DRAWN BY JVA

Scale: 1:15

Sheet No. 1 /

DETAIL B-1.1:

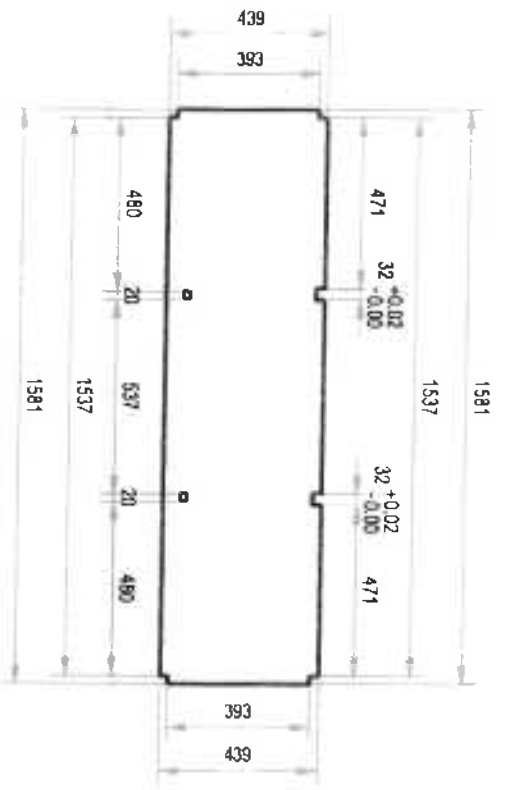

QUANTITY: 2

DETAIL B-1.3:

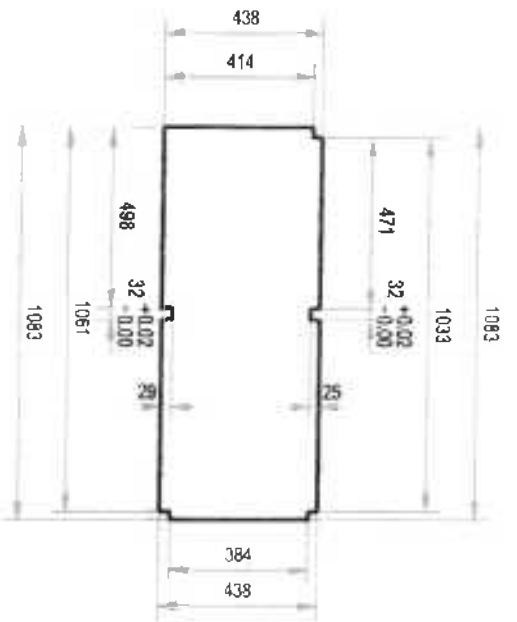

QUANTITY: 1

DETAIL B-1.4:

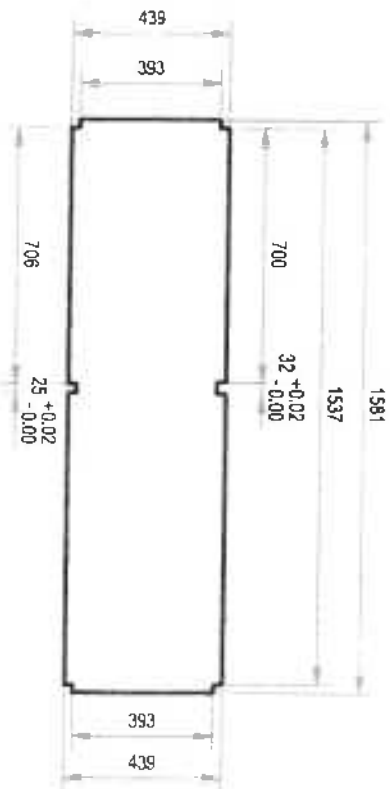

DETAIL B-1.2:

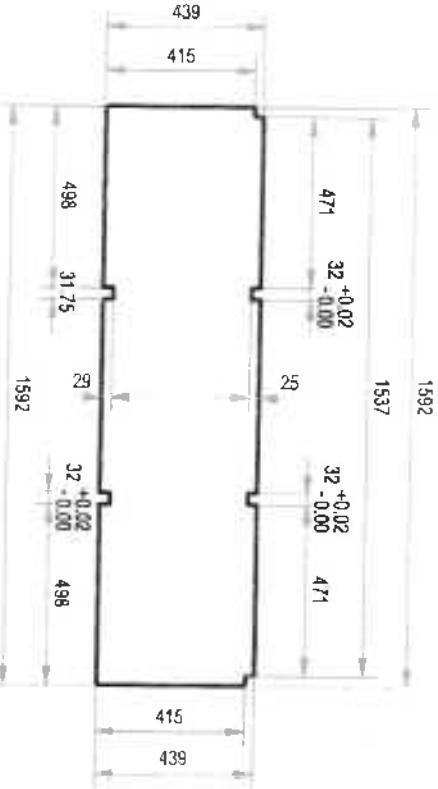

QUANTITY: 1

GALVANIZED SHEET GAUGE #18, PAINTED

PRODUCED BY AN AUTODESK EDUCATIONAL PRODUCT

QUANTITY: 2



TECHNICAL EDUCATION AND SKILLS DEVELOPMENT AUTHORITY

PROJECT TITLE
MOBILE TRAINING LABORATORY

DRAWN BY: JVA

Scale: 1:20

Sheet No. 1/1

Handwritten initials and marks

DETAIL C-1.1:

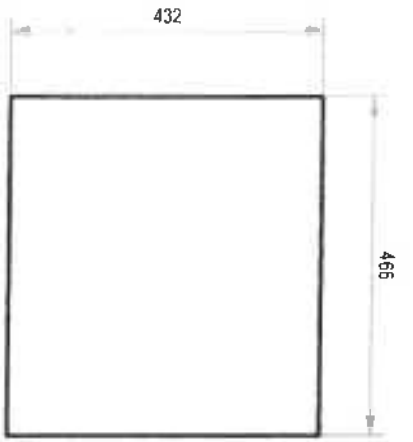

QUANTITY: 15

DETAIL C-1.2:

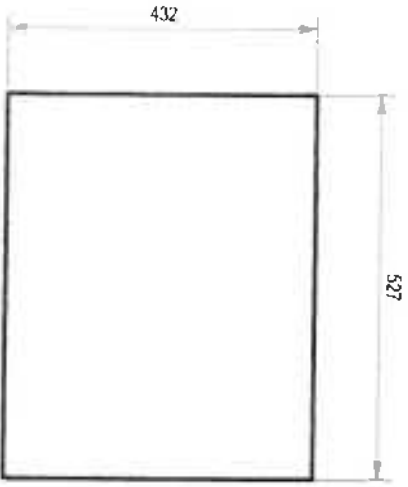

QUANTITY: 9

DETAIL C-1.3:

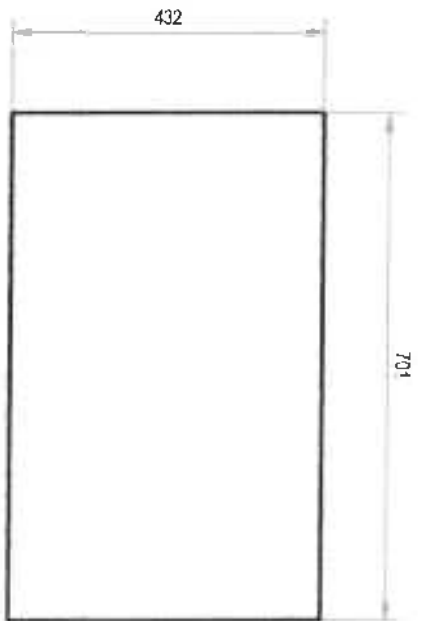

QUANTITY: 2

DETAIL D-1.1:

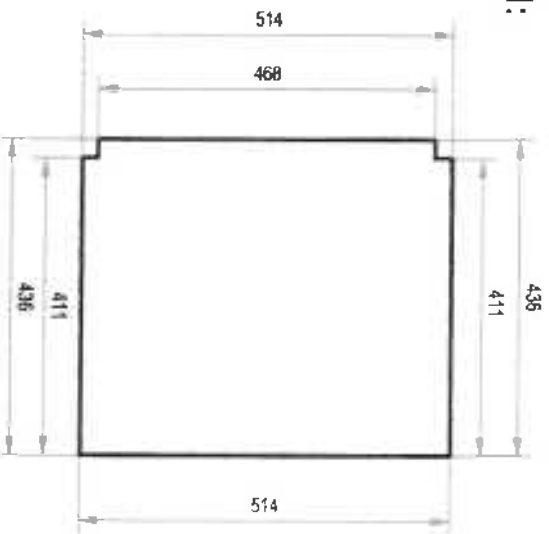

QUANTITY: 1

GALVANIZED SHEET GAUGE #18, PAINTED



TECHNICAL EDUCATION AND SKILLS DEVELOPMENT AUTHORITY

PROJECT TITLE
MOBILE TRAINING LABORATORY

N

Handwritten marks: a circle with a checkmark and the number 1.

Scale 1:10



A

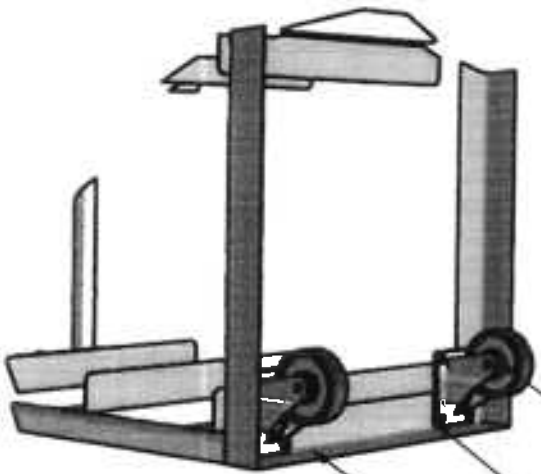

A (1 : 10)

4 pcs. of 4" polyurethane roller wheels with top plate bearing and self-locking; load capacity: 125 lbs. per wheel

Welded in 4" x 4" x 5 mm metal plate

2" x 2" x 3/16" bar, painted

PRODUCED BY AN AUTODESK EDUCATIONAL PRODUCT



TECHNICAL EDUCATION AND SKILLS DEVELOPMENT AUTHORITY

PROJECT TITLE
MOBILE TRAINING LABORATORY

N

DRAWN BY: JPA Scale: 1:20

Sheet No. 1 /

| MTL BOX COVER FRAME, SIDEWAY SWING | | | |
|------------------------------------|------------------------------|-------------|-----|
| NO | MATERIAL | LENGTH, mm | Qty |
| 1 | Gauge #18 G.I. sheet | 1,009 x 835 | 2 |
| 2 | 1" x 1" x 1.5 mm square tube | 968,25 | 4 |
| 3 | 1" x 1" x 1.5 mm square tube | 928,25 | 2 |
| 4 | 1" x 1" x 1.5 mm square tube | 793,65 | 4 |
| 5 | 1" x 1" x 1.5 mm square tube | 369,825 | 8 |
| 6 | 2" x 2mm piano hinge | 968 | 2 |
| TOTAL | | | 22 |

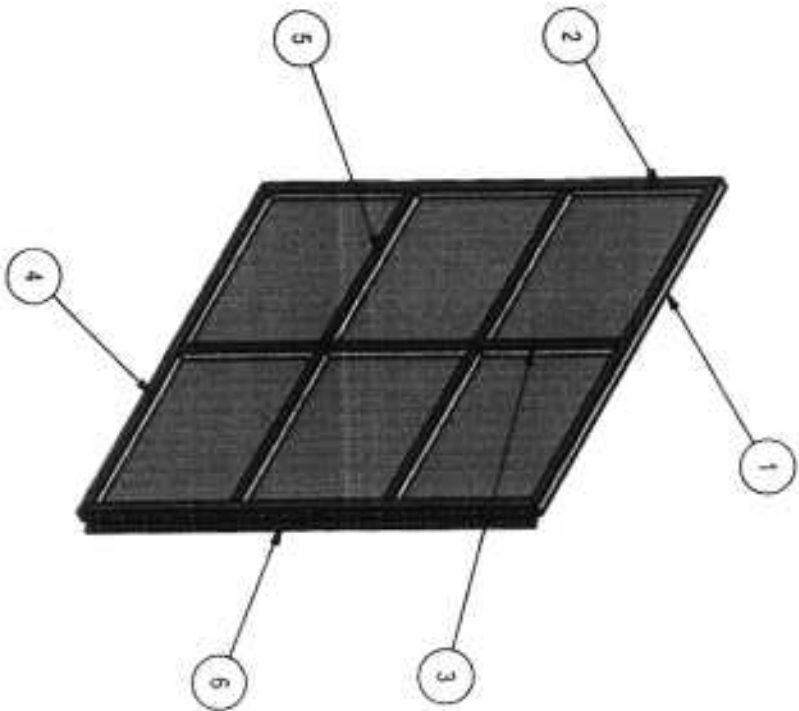

MTL DOOR FRAME



PROJECT TITLE
MOBILE TRAINING
LABORATORY

N

DRAWN BY: JVA

Scale: 1:15

Sheet No.
1/1

DETAIL F: RUBBER DOOR SEAL

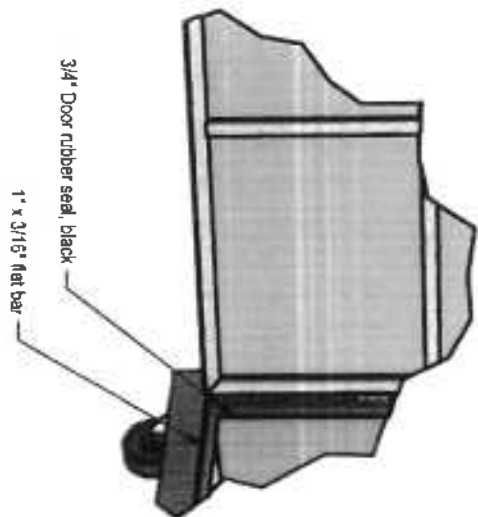
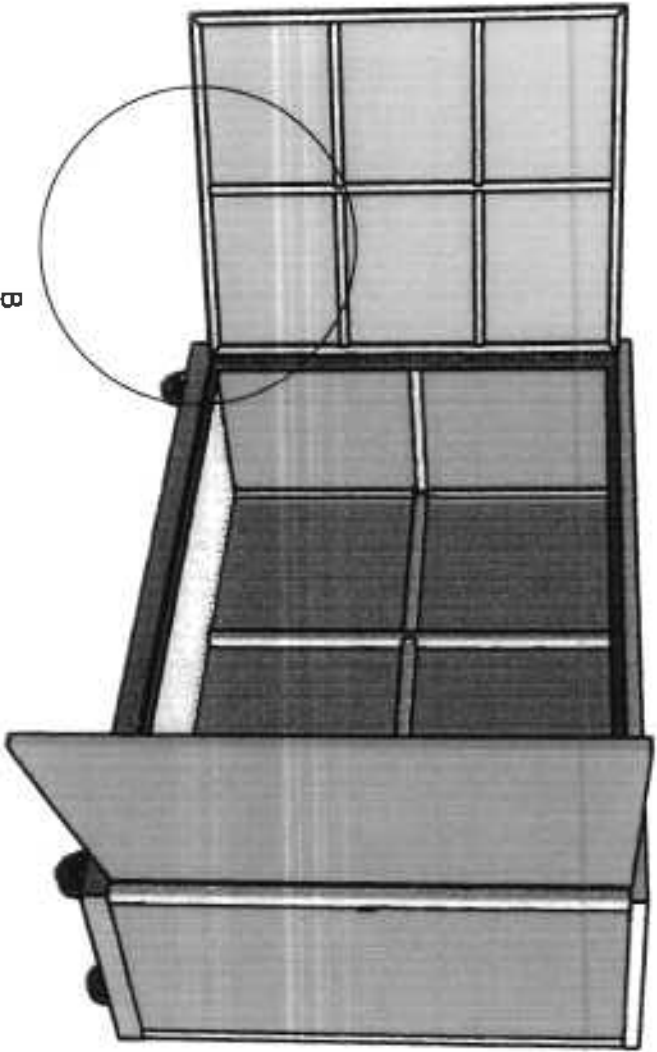

B (1:10)

6
 7
 [Handwritten initials]
 [Handwritten initials]

| | | | | |
|---|---------------------------------------|---------------------------------------|--------------------|----------------------------|
|  <p>TECHNICAL EDUCATION AND SKILLS DEVELOPMENT AUTHORITY</p> | PROJECT TITLE | <p>MOBILE TRAINING LABORATORY</p> | <p>Scale: 1/25</p> | <p>Standard No. 1/</p> |
| | <p>MOBILE TRAINING LABORATORY</p> | | | |

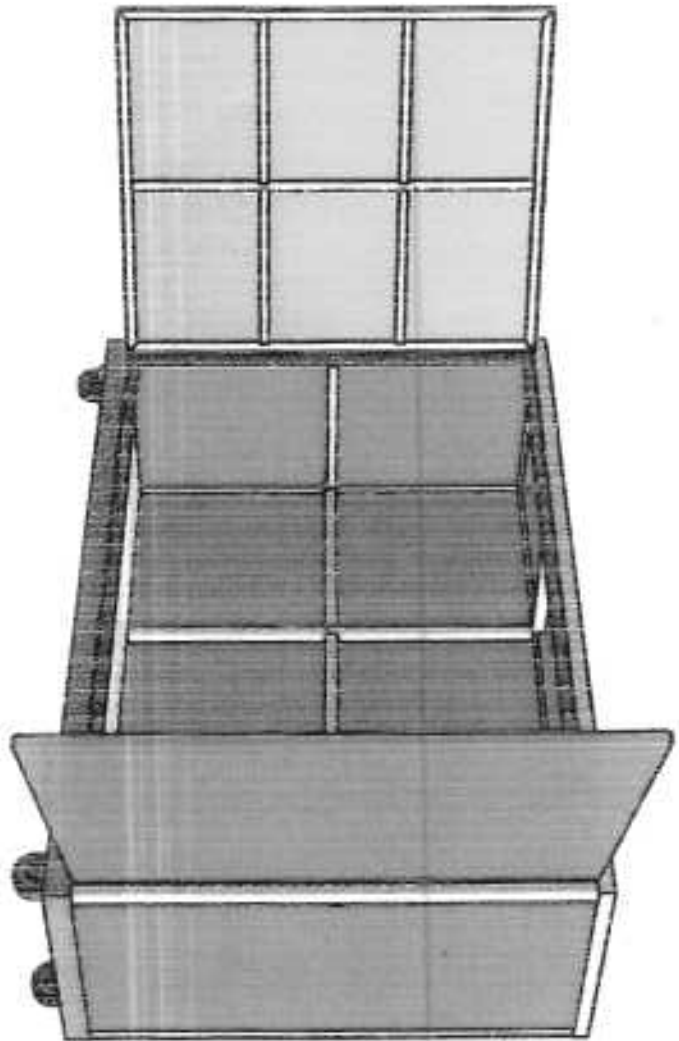

Include 2-sides metal handle
and lock with padlock for the
door (not shown in the drawing)

b r

N



TECHNICAL
EDUCATION AND
SKILLS
DEVELOPMENT
AUTHORITY

PROJECT TITLE
**MOBILE TRAINING
LABORATORY**

Lesson 11 - 2nd

30/06/2018

1 / 1

COMPARATIVE TECHNICAL SPECIFICATION

| TESDA'S SPECIFICATIONS | | BIDDER'S SPECIFICATIONS | | |
|------------------------|---|--------------------------------------|------------------|----------------|
| No. | Item | Specifications | Item/Brand/Model | Specifications |
| Lot 4 | Cookery NC II with Plastic Box MTL Box No. 5 | Please refer to the attached drawing | | |

Name of Bidder: _____

Name and Signature of Authorized Representative: _____
 Position/Designation: _____
 Date: _____

Handwritten signature and initials

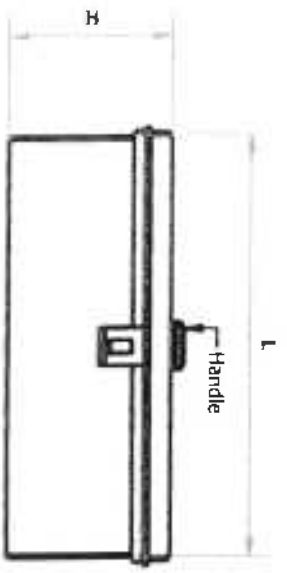

FRONT VIEW

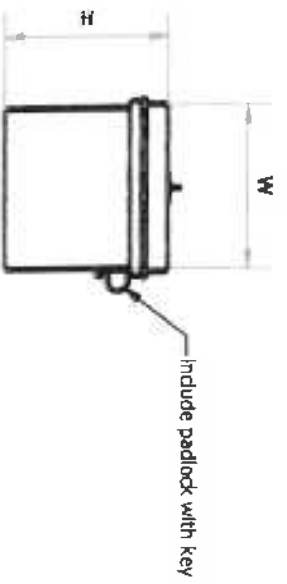

SIDE VIEW

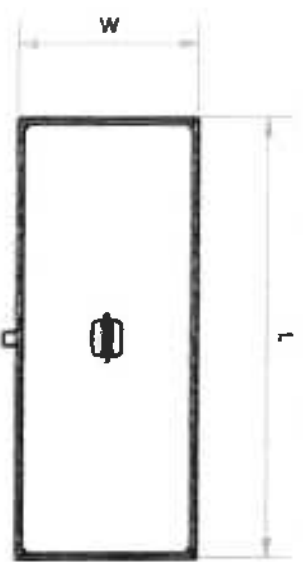

TOP VIEW

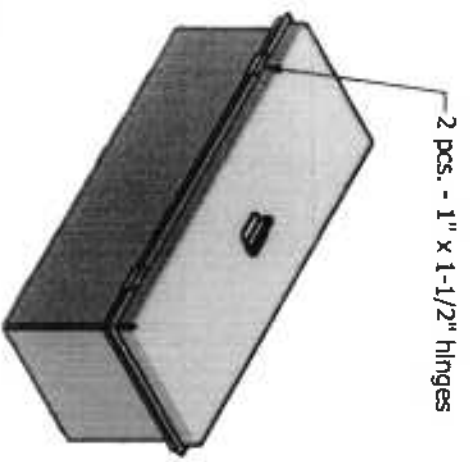

ISOMETRIC VIEW

| TOOLBOX | | | |
|---------|-----------------------|--|---------------------|
| NO. | DIMENSION (L x W x H) | MATERIAL | NO. OF PCS. PER SET |
| 1 | 18" x 7" x 7" | Small Engine Repair - G.A. #18 galvanized sheet, painted | 12 |
| 3 | 18" x 7" x 8" | Appliance Repair - G.A. #18 galvanized sheet, painted | 6 |
| | 18" x 7" x 8" | Electrical Installation and Maintenance - G.A. #18 galvanized sheet, painted | 6 |
| 4 | 20" x 7" x 8" | Small Engine Repair - G.A. #18 galvanized sheet, painted | 6 |
| 5 | 16" x 20" x 4-1/2" | Cookery - Plastic, white | 3 |
| 6 | 16" x 20" x 4-1/2" | Food Processing - Plastic, white | 3 |

2 9 2



TECHNICAL EDUCATION AND SKILLS DEVELOPMENT AUTHORITY

PROJECT TITLE
COMPACT MOBILE UNIT

Drawn by: J.A. Scale: 1:1 Sheet No: 1/1

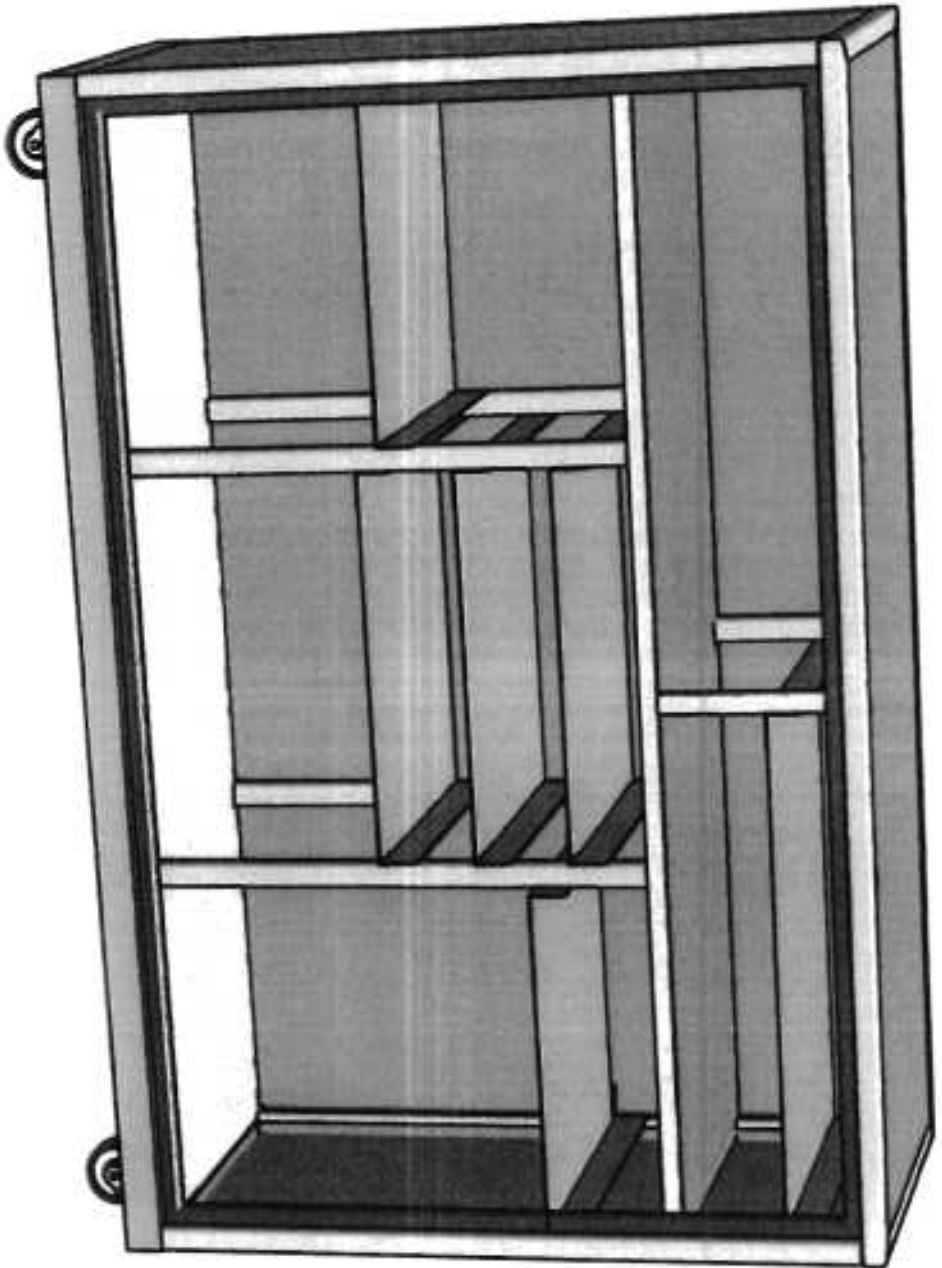

**MTL BOX NO. 5
(COOKERY)
QUANTITY:**
(The door is not shown in the drawing)

PRODUCED BY AN AUTODESK EDUCATIONAL PRODUCT



TECHNICAL
EDUCATION AND
SKILLS
DEVELOPMENT
AUTHORITY

PROJECT TITLE
**MOBILE TRAINING
LABORATORY**

DRAWN BY JVA

SCALE 1/10

DATE 11/

Handwritten initials and marks

Handwritten initials and marks

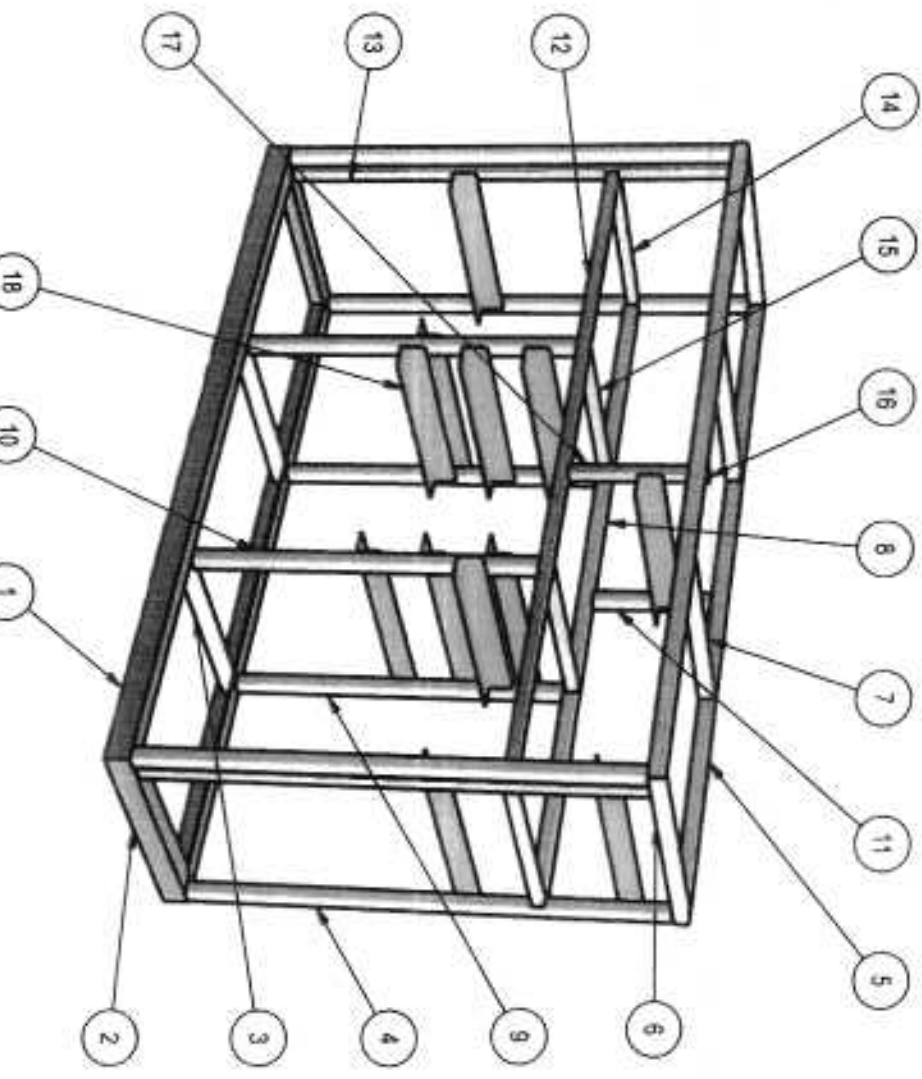

| MTL BOX 5 FRAME | | | |
|-----------------|---|------------|------|
| NO. | MATERIAL | LENGTH, mm | Qty. |
| 1 | 2" x 2" x 3/16" angle bar | 1,600.00 | 2 |
| 2 | 2" x 2" x 3/16" angle bar | 500.00 | 2 |
| 3 | 1 1/4" x 1 1/4" x 2 mm square tube | 493.65 | 2 |
| 4 | 1 1/4" x 1 1/4" x 2 mm square tube | 968.25 | 4 |
| 5 | 1 1/4" x 1 1/4" x 2 mm square tube | 1,600.00 | 2 |
| 6 | 1 1/4" x 1 1/4" x 2 mm square tube | 500.00 | 2 |
| 7 | 1 1/4" x 1 1/4" x 2 mm square tube | 436.50 | 2 |
| 8 | 1 1/4" x 1 1/4" x 2 mm square tube | 1,536.50 | 1 |
| 9 | 1 1/4" x 1 1/4" x 2 mm square tube | 688.25 | 2 |
| 10 | 1 1/4" x 1 1/4" x 2 mm square tube | 695.00 | 2 |
| 11 | 1 1/4" x 1 1/4" x 2 mm square tube | 248.25 | 1 |
| 12 | 1 1/4" x 1 1/4" x 2 mm square tube | 1,536.50 | 1 |
| 13 | 1" x 1" x 1.5 mm square tube | 968.25 | 2 |
| 14 | 1" x 1" x 1.5 mm square tube | 393.25 | 2 |
| 15 | 1" x 1" x 1.5 mm square tube | 392.04 | 2 |
| 16 | 1" x 1" x 1.5 mm square tube | 43.25 | 1 |
| 17 | 1" x 1" x 1.5 mm square tube | 253.79 | 1 |
| 18 | Gauge #18 GI sheet, 2" x 2" @ 90 degrees bend | 431.70 | 12 |
| TOTAL | | | 43 |

MTL BOX NO. 5 FRAME (COOKERY)
 (The door is not shown in the drawing)



TECHNICAL
EDUCATION AND
SKILLS
DEVELOPMENT
AUTHORITY

PROJECT TITLE

**MOBILE TRAINING
LABORATORY**

DRAWN BY: JPA

Scale: 1:15

Sheet No: 1/1

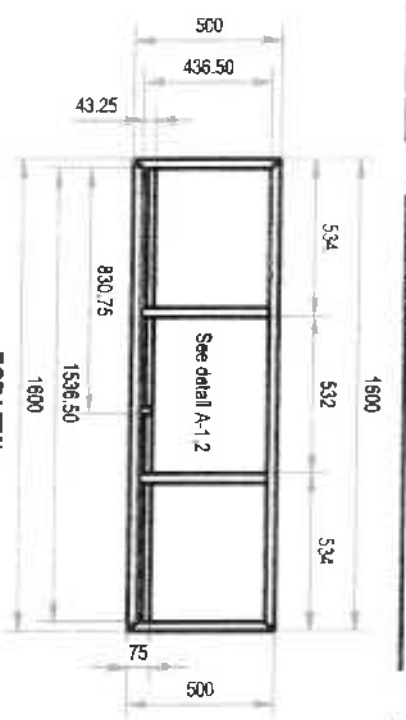

TOP VIEW

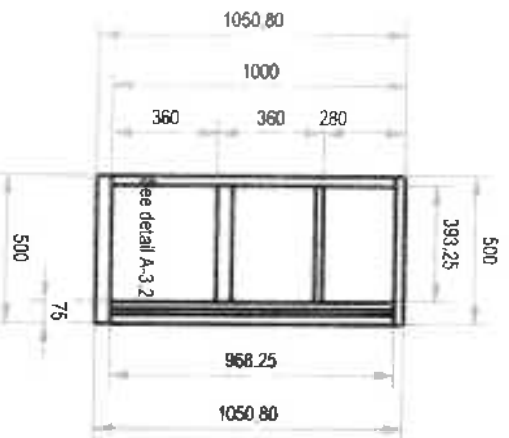

LEFT SIDE VIEW

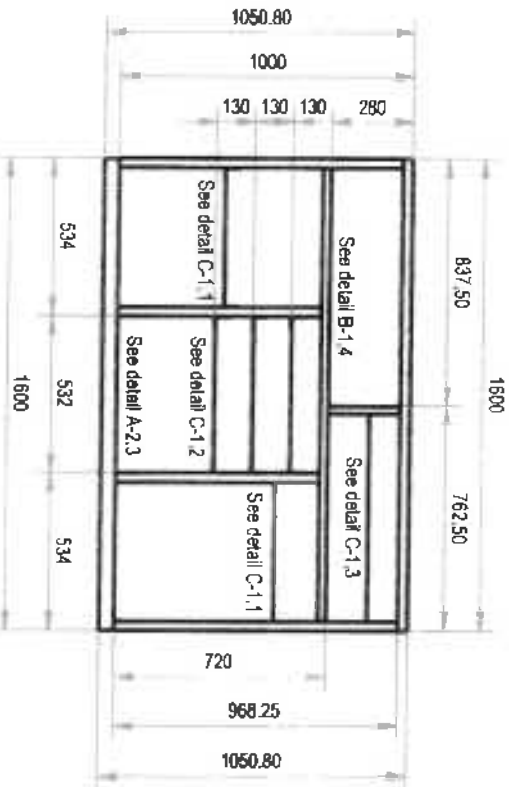

FRONT VIEW

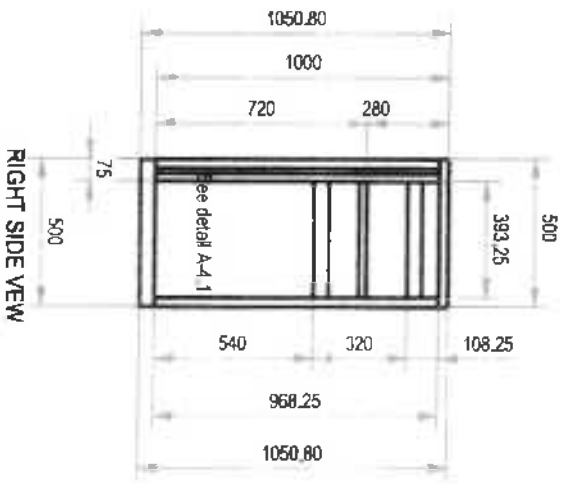

RIGHT SIDE VIEW

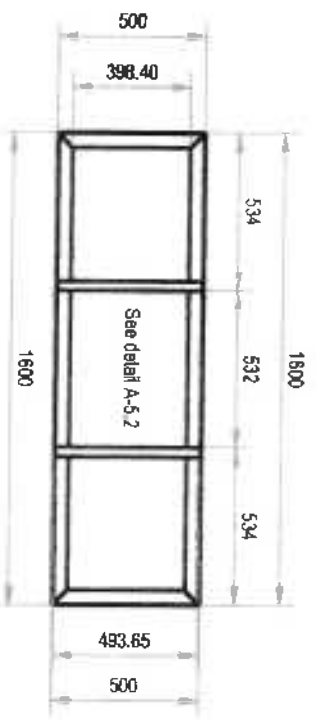

BOTTOM VIEW

**MTL BOX NO. 5 FRAME
(COOKERY)**

(The door is not shown in the drawing)

MTL BOX NO. 5
 All materials must be painted with anti-corrosive primer
 Tube end bar are coated with light grey epoxy finish paint



TECHNICAL
EDUCATION AND
SKILLS
DEVELOPMENT
AUTHORITY

PROJECT TITLE
**MOBILE TRAINING
LABORATORY**

Drawn by: JSA
Scale: 1:25
Sheet No: 1/1

Handwritten signature and initials

DETAIL A-1.1:

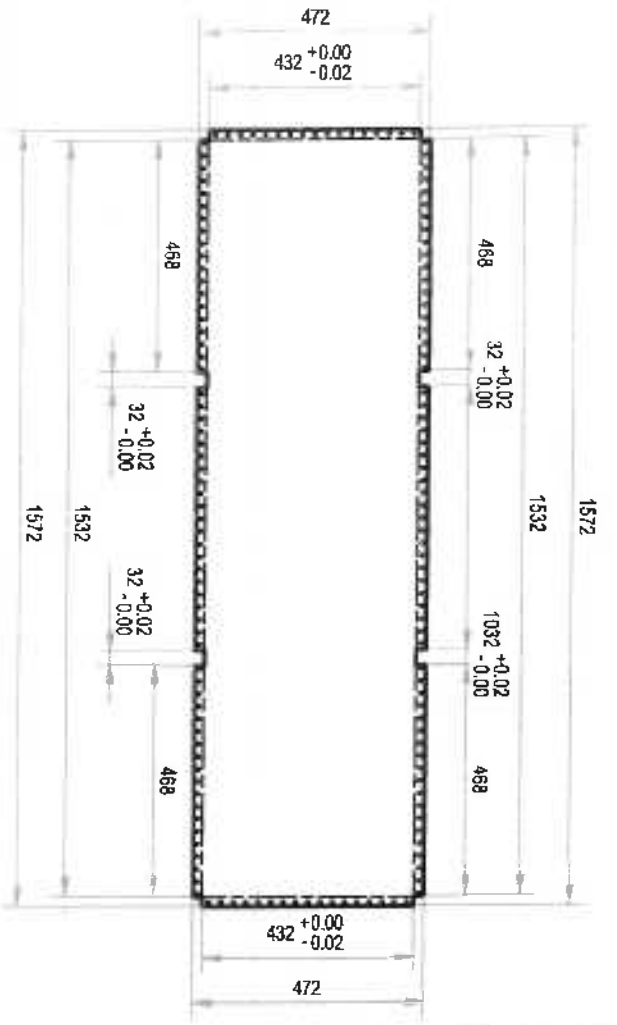

QUANTITY: 5

DETAIL A-1.3:

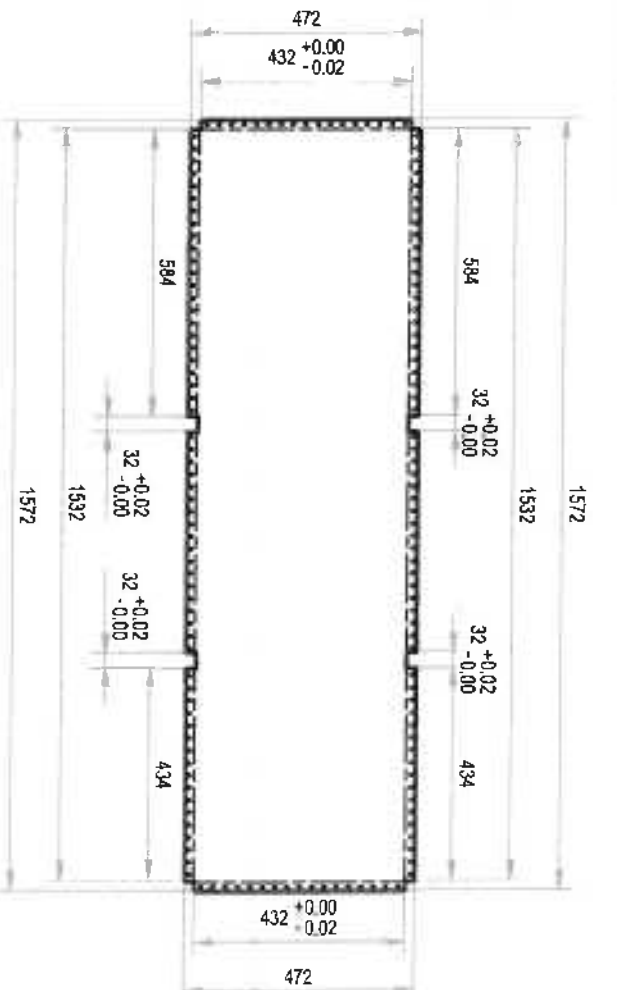

QUANTITY: 1

DETAIL A-1.2:

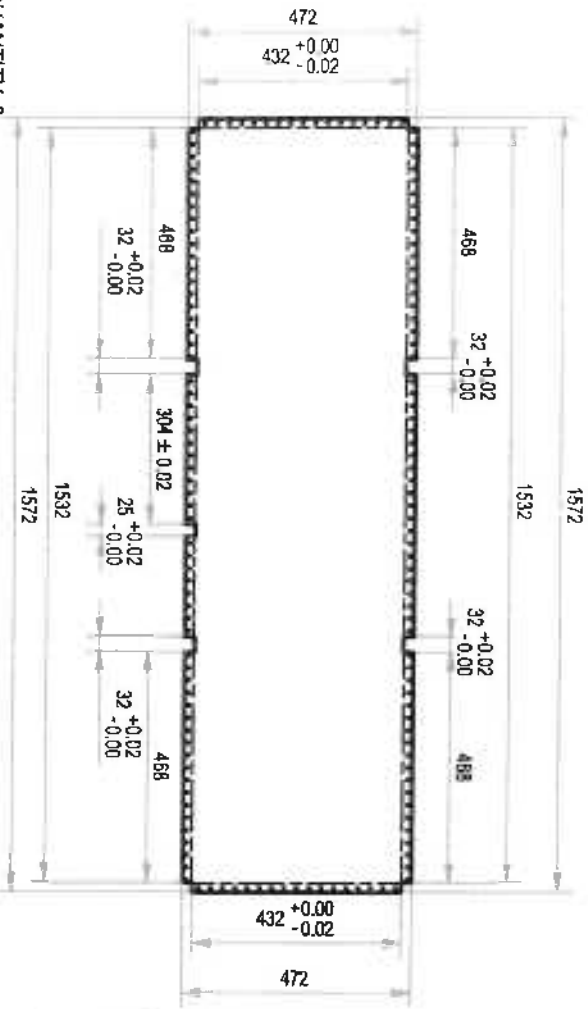

QUANTITY: 2

DETAIL A-1.4:

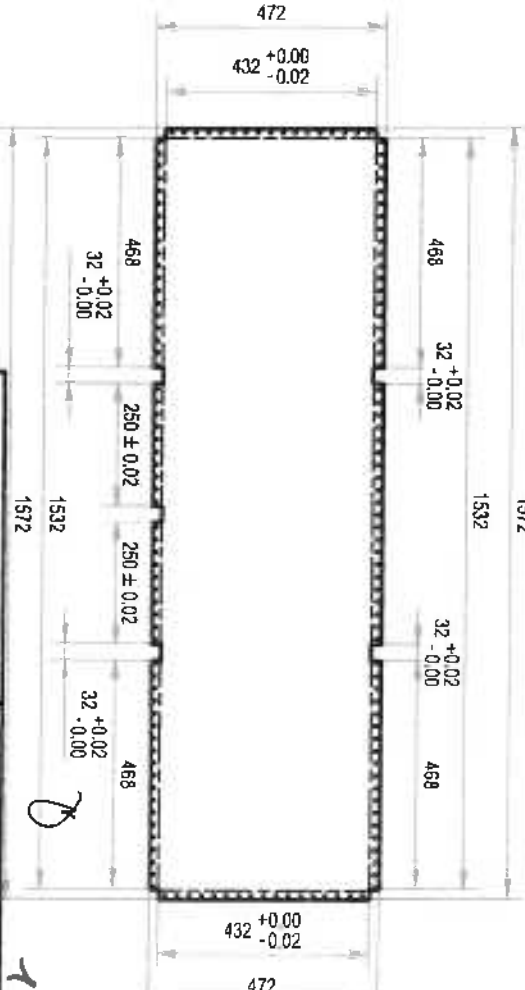

QUANTITY: 2

FLAT PATTERN: GALVANIZED SHEET GAUGE #18, PAINTED

Use 3/16" blind rivet spaced @ 1" O.C.



TECHNICAL EDUCATION AND SKILLS DEVELOPMENT AUTHORITY

PROJECT TITLE
MOBILE TRAINING LABORATORY

DRAWN BY: JPA

Scale: 1:15

Sheet No. 1/1

1

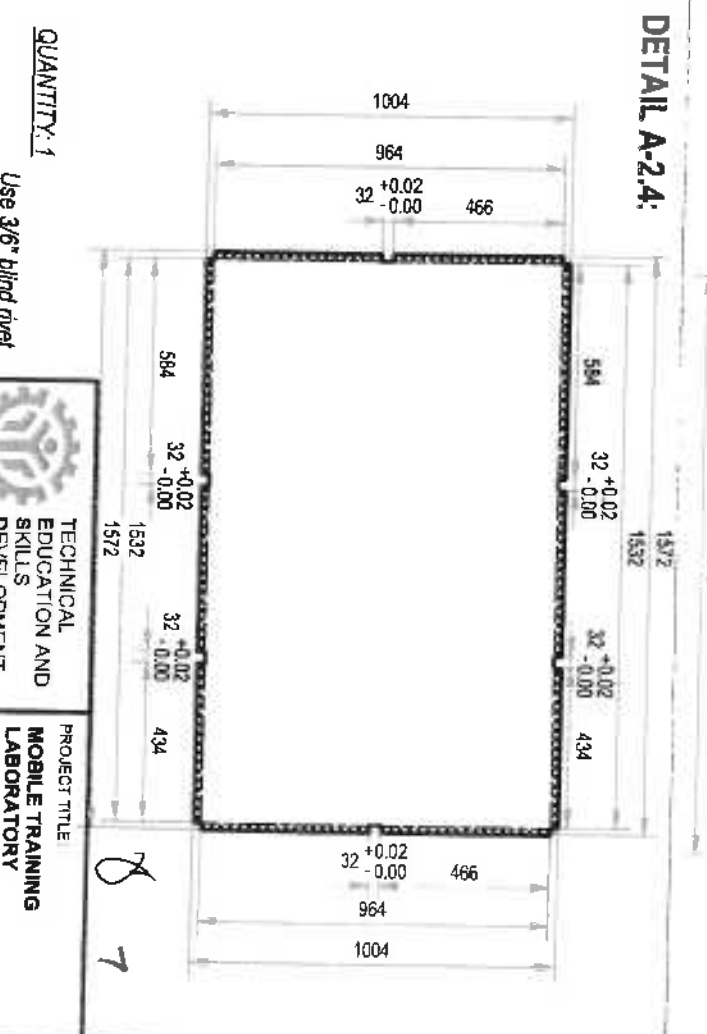
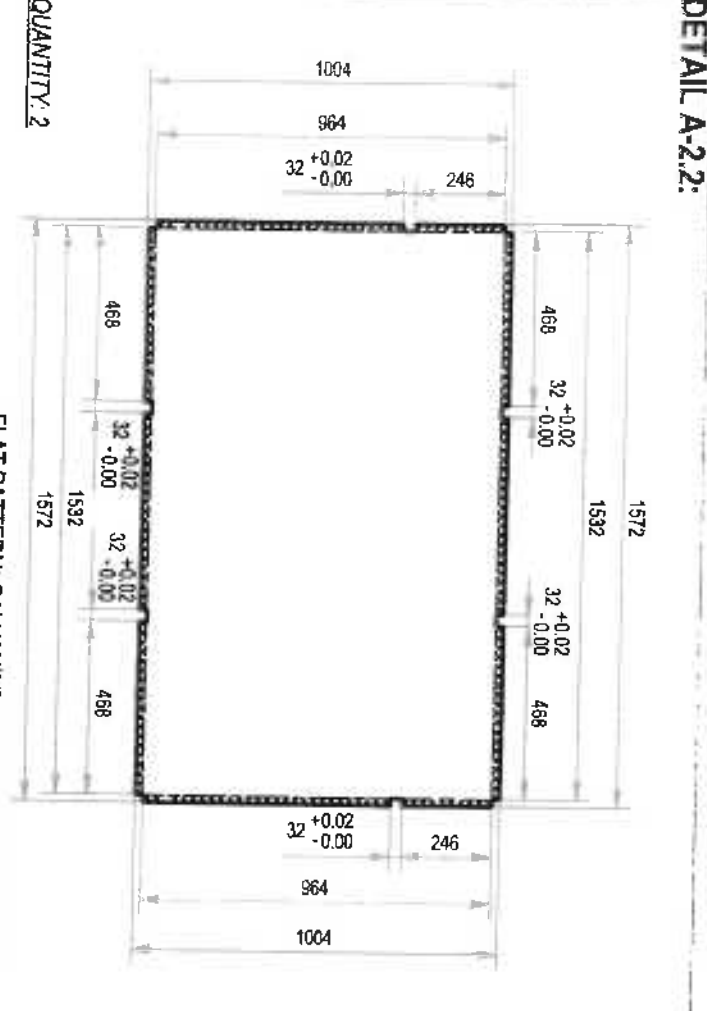
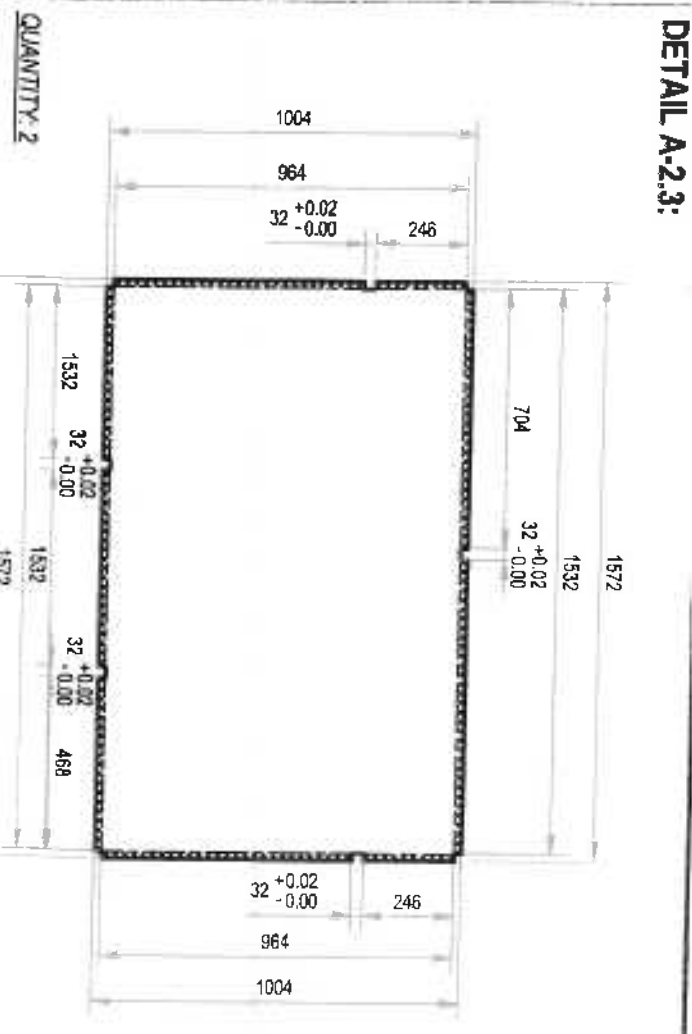
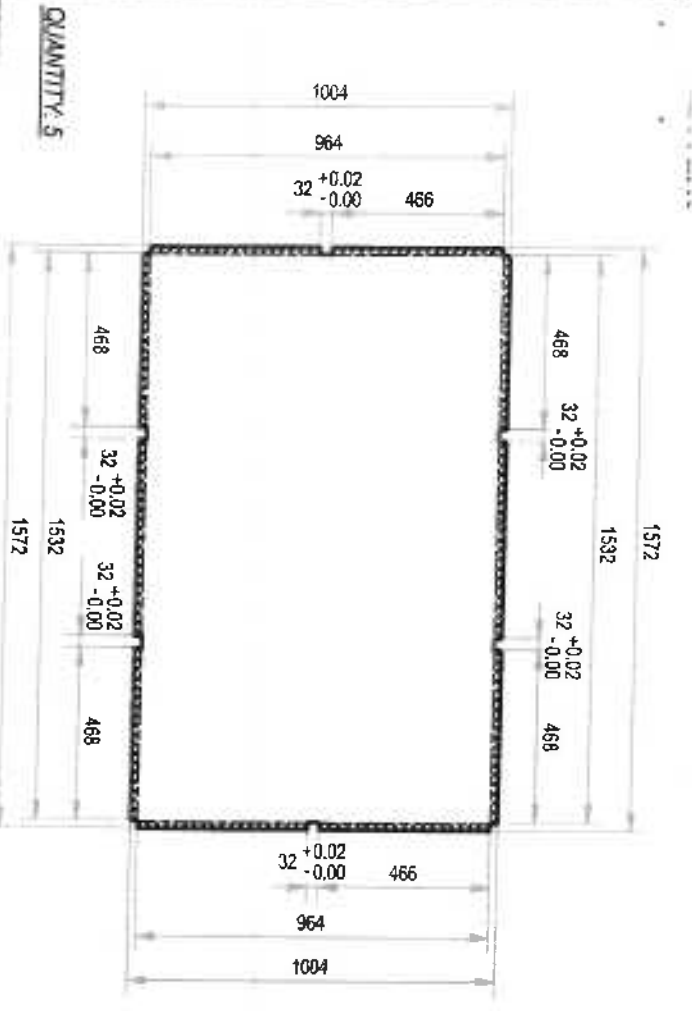

FLAT PATTERN: GALVANIZED SHEET GAUGE #18, PAINTED

PRODUCED BY AN AUTODESK EDUCATIONAL PRODUCT

Use 3/6" blind rivet spaced @ 1' O.C.

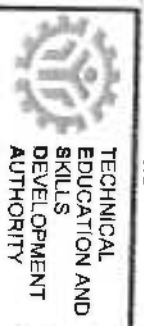

PROJECT TITLE
MOBILE TRAINING LABORATORY

DRAWN BY: JVA
SCALE: 1/20
SHEET NO: 1/1

DETAIL A-3.1:

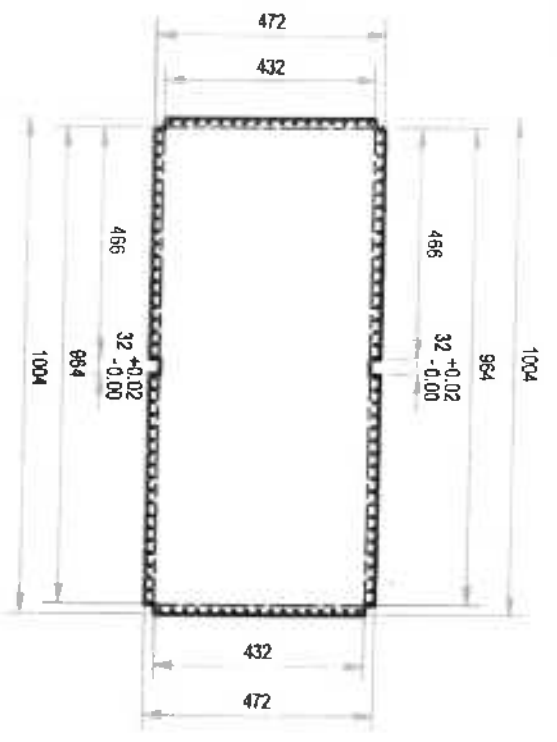

QUANTITY: 5

DETAIL A-3.2:

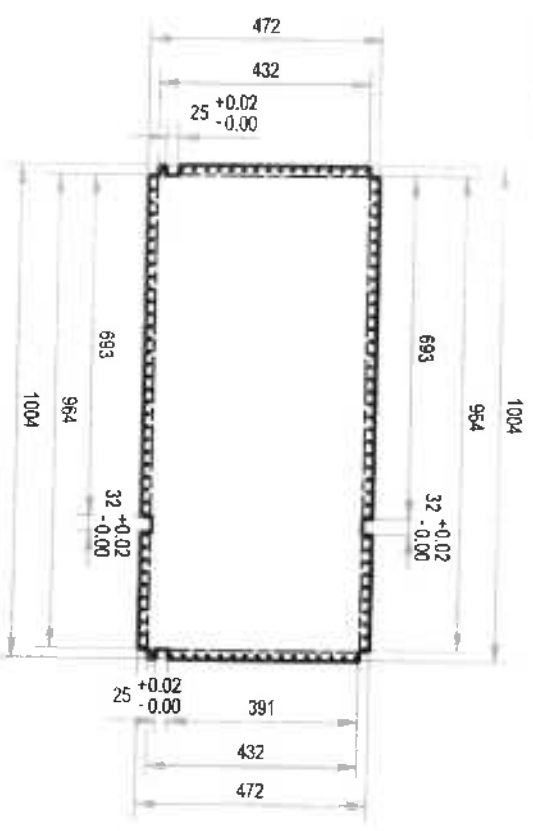

QUANTITY: 4

FLAT PATTERN: GALVANIZED SHEET GAUGE #18, PAINTED

PRODUCED BY AN AUTODESK EDUCATIONAL PRODUCT

DETAIL A-3.3:

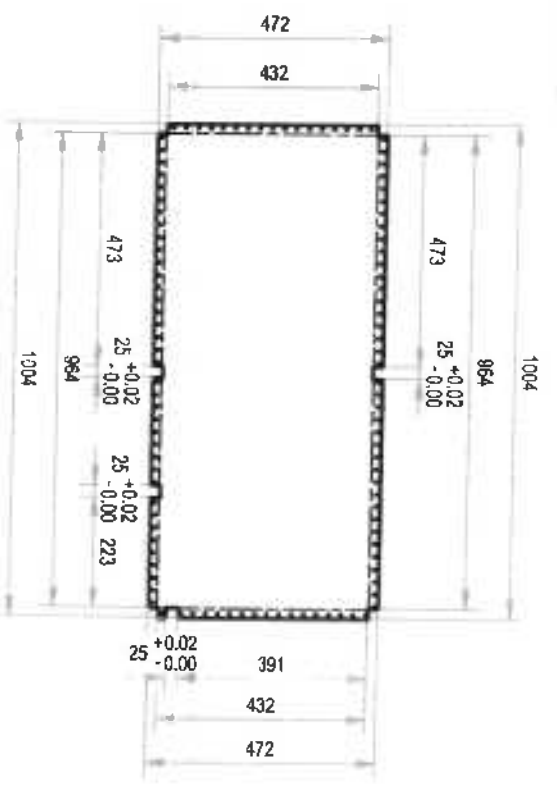

QUANTITY: 1

DETAIL A-3.4:

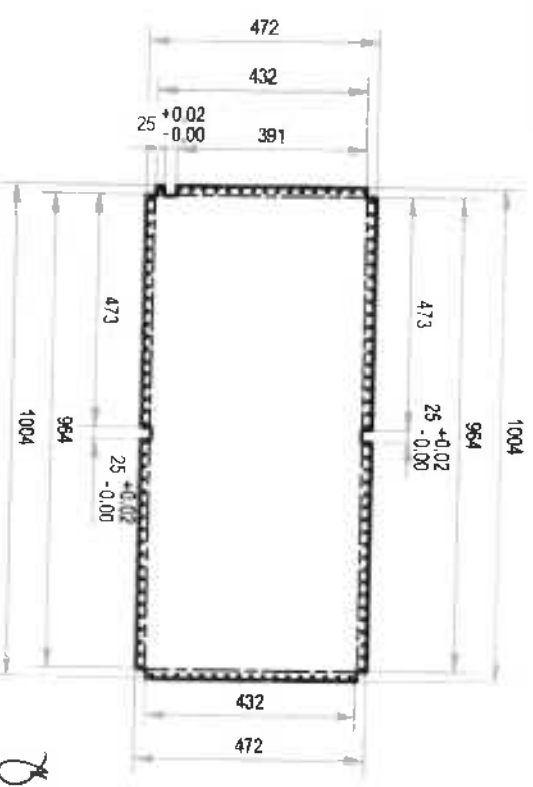

QUANTITY: 2

Use 3/16" blind rivet spaced @ 1" O.C.



TECHNICAL EDUCATION AND SKILLS DEVELOPMENT AUTHORITY

PROJECT TITLE
MOBILE TRAINING LABORATORY

Drawn by: JJA

Scale: 1:15

Sheet No. 1 /

DETAIL A-4.1:

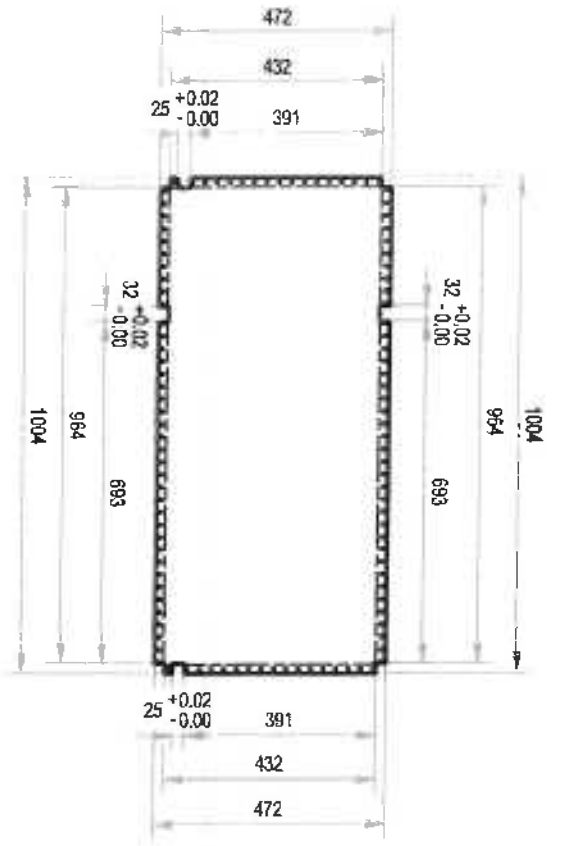

QUANTITY: 4

DETAIL A-4.2:

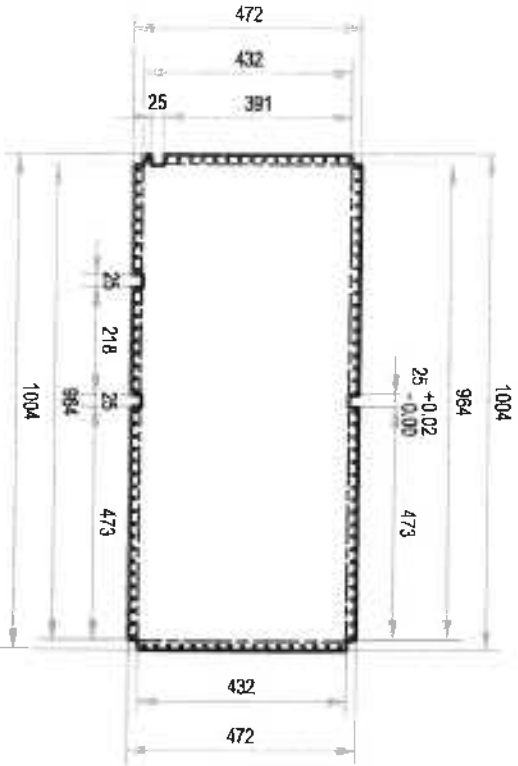

QUANTITY: 2

DETAIL A-4.3:

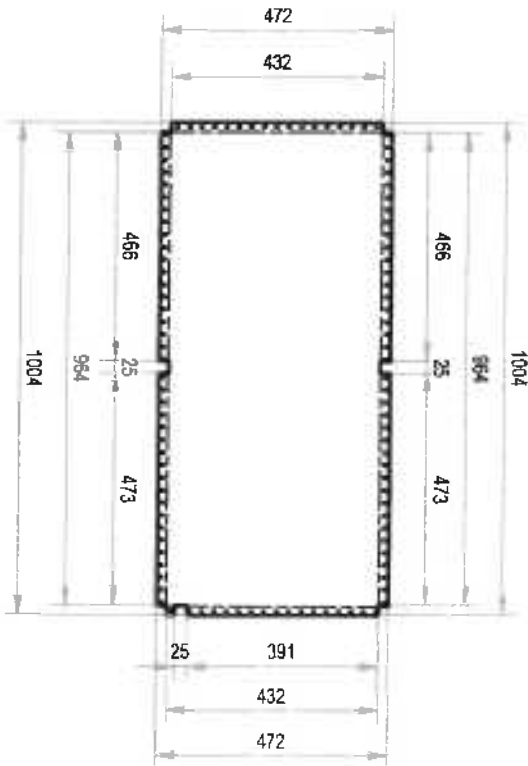

QUANTITY: 2

FLAT PATTERN: GALVANIZED SHEET GAUGE #18, PAINTED

Use 3/16" blind rivet spaced @ 1" O.C.



TECHNICAL EDUCATION AND SKILLS DEVELOPMENT AUTHORITY

PROJECT TITLE: MOBILE TRAINING LABORATORY

Drawn by: JVA Scale: 1:15

Sheet No. 1 /

Handwritten marks: a large '2' and a '1'.

Handwritten initials: 'JVA' and '9/1'.

DETAIL A-5.1:

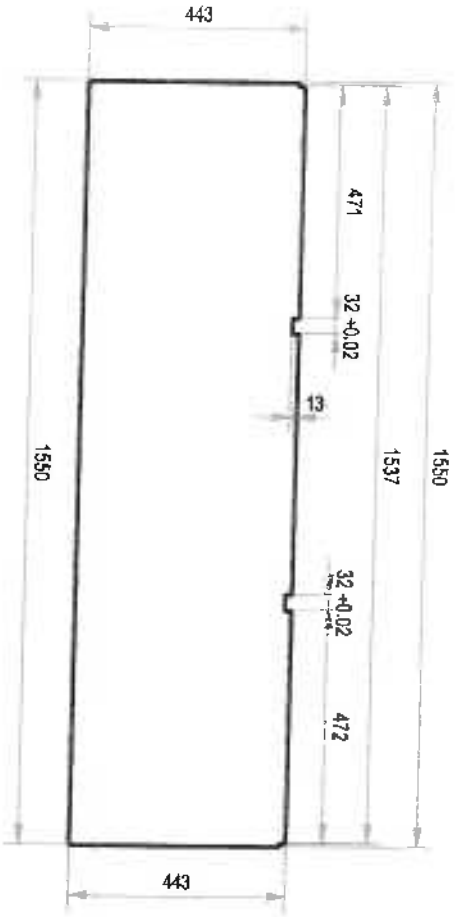

QUANTITY: 1

DETAIL A-5.2:

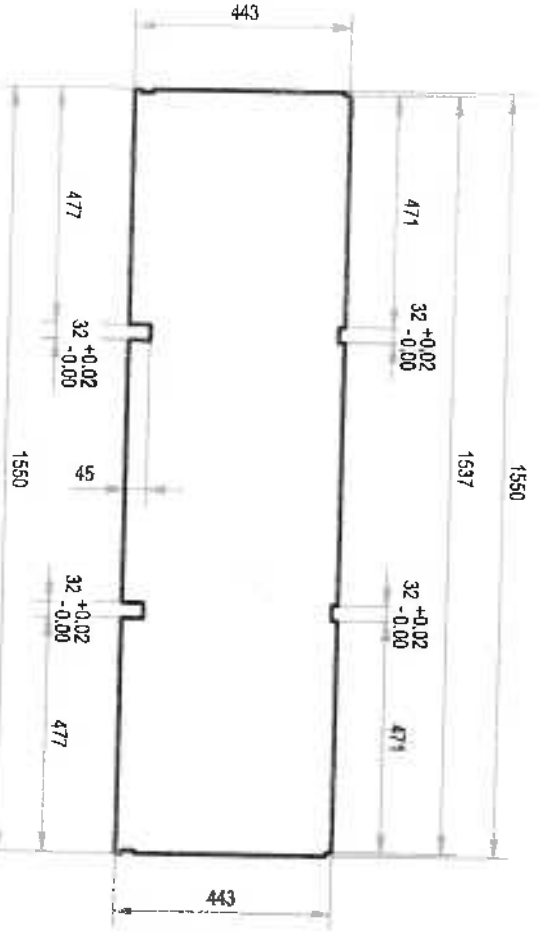

QUANTITY: 6

DETAIL A-5.3:

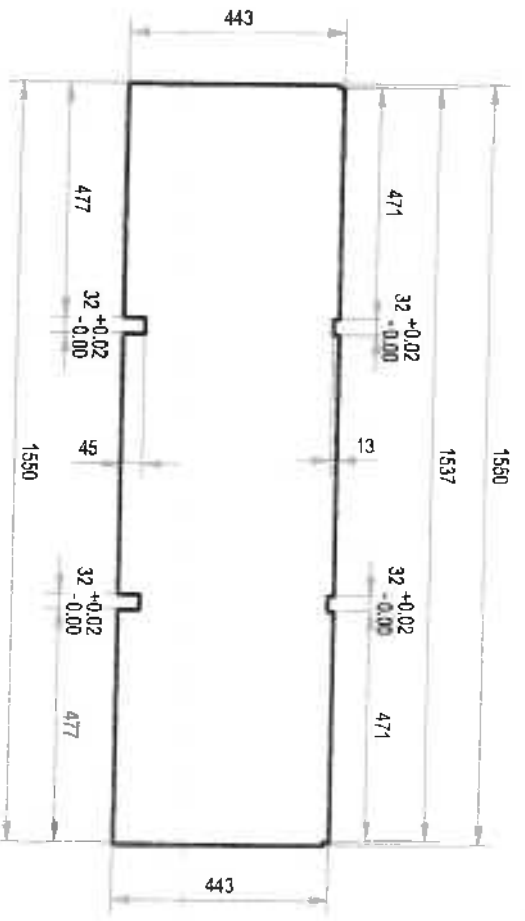

QUANTITY: 2

DETAIL A-5.4:

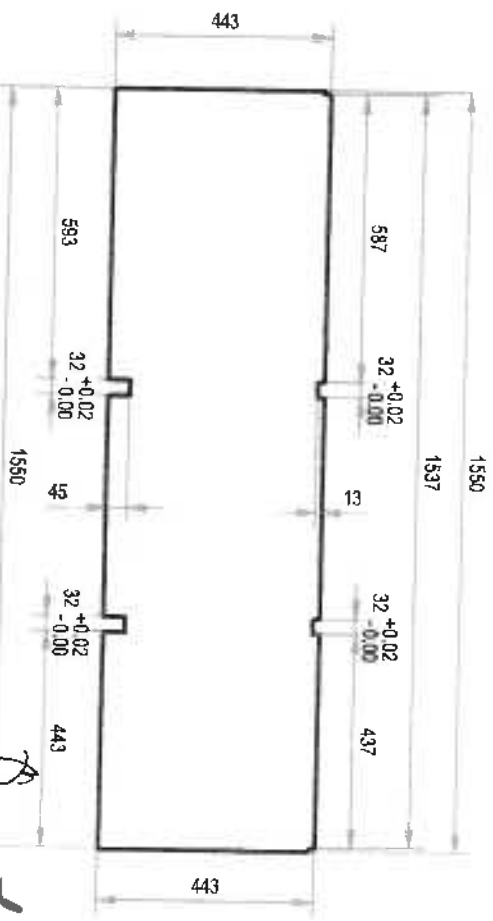

QUANTITY: 1

GALVANIZED SHEET GAUGE #18, PAINTED

PRODUCED BY AN AUTODESK EDUCATIONAL PRODUCT



TECHNICAL EDUCATION AND SKILLS DEVELOPMENT AUTHORITY

PROJECT TITLE: MOBILE TRAINING LABORATORY

DRAWN BY: JWA

SCALE: 1:15

SHEET NO: 1/1

Handwritten initials and marks, including a large 'N' and a signature.

DETAIL B-1.1:

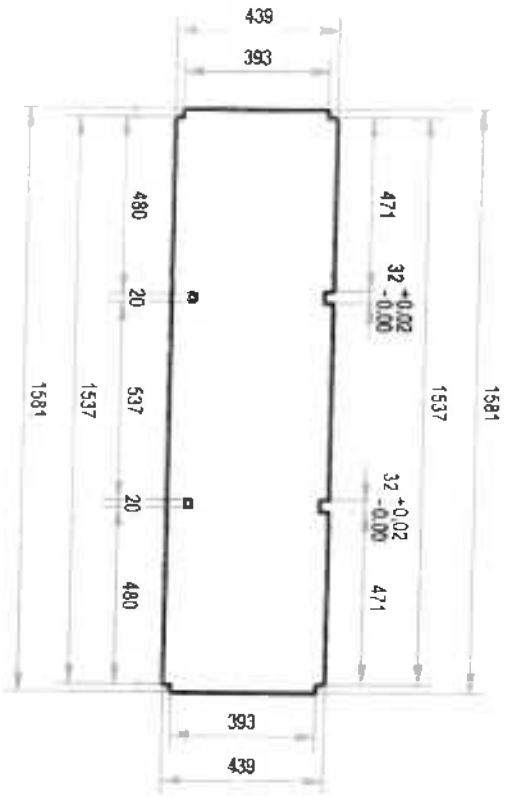

QUANTITY: 2

DETAIL B-1.2:

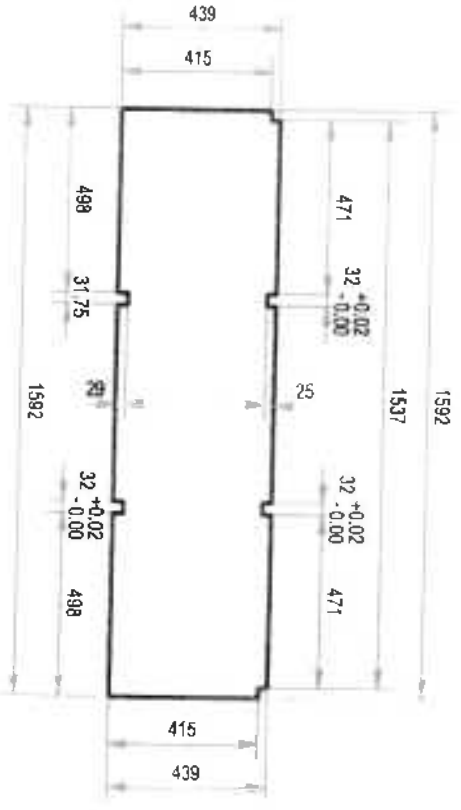

QUANTITY: 1

DETAIL B-1.3:

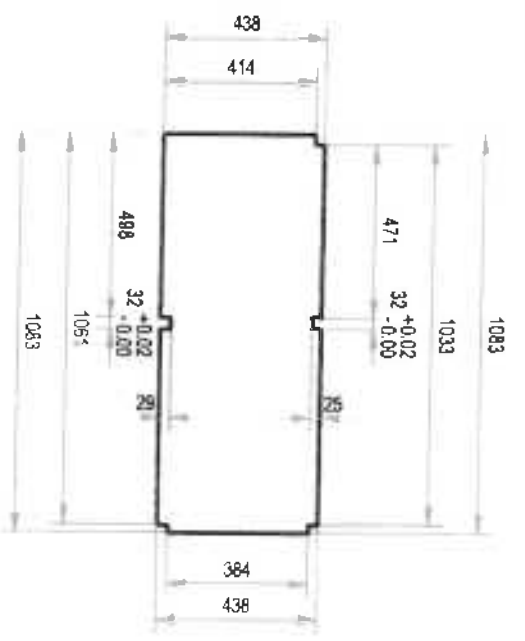

QUANTITY: 1

DETAIL B-1.4:

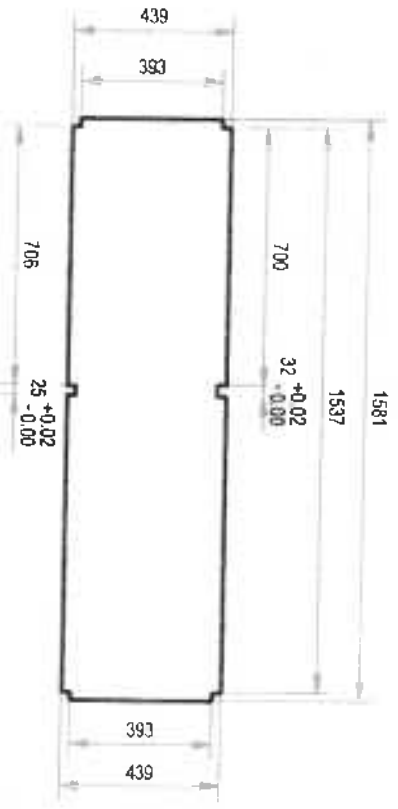

QUANTITY: 2

GALVANIZED SHEET GAUGE #18, PAINTED

PRODUCED BY AN AUTODESK EDUCATIONAL PRODUCT



TECHNICAL
EDUCATION AND
SKILLS
DEVELOPMENT
AUTHORITY

PROJECT TITLE
**MOBILE TRAINING
LABORATORY**

DESIGNED BY: JVA
Scale: 1:20
Sheet No:
1 /

PRODUCED BY AN AUTODESK EDUCATIONAL PRODUCT

DETAIL C-1.1:

QUANTITY: 15

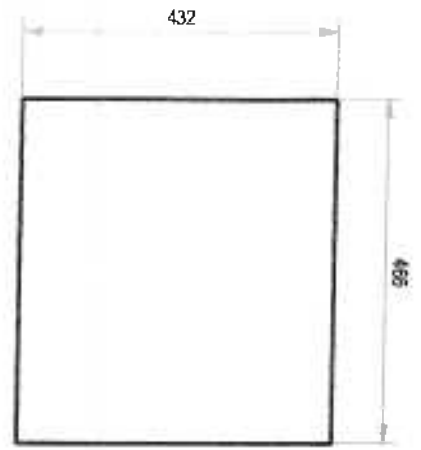

DETAIL C-1.3:

QUANTITY: 2

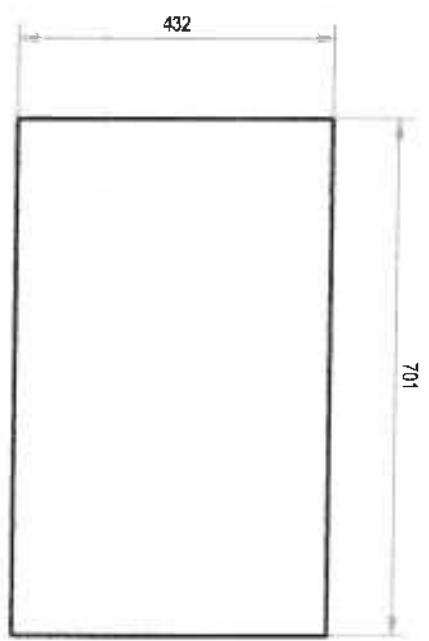

DETAIL C-1.2:

QUANTITY: 9

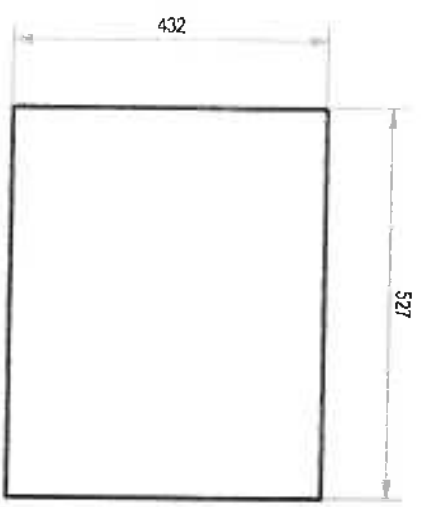

DETAIL D-1.1:

QUANTITY: 1

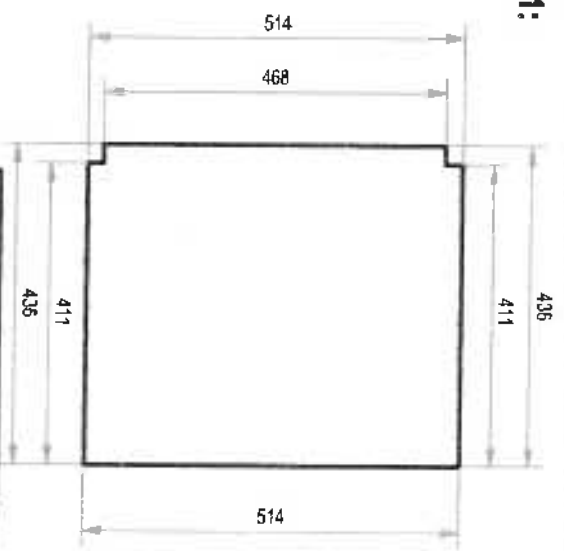

GALVANIZED SHEET GAUGE #18, PAINTED



TECHNICAL EDUCATION AND SKILLS DEVELOPMENT AUTHORITY

PROJECT TITLE
MOBILE TRAINING LABORATORY

DRAWN BY: JSA

Scale: 1:10

Sheet No: 1 /

PRODUCED BY AN AUTODESK EDUCATIONAL PRODUCT

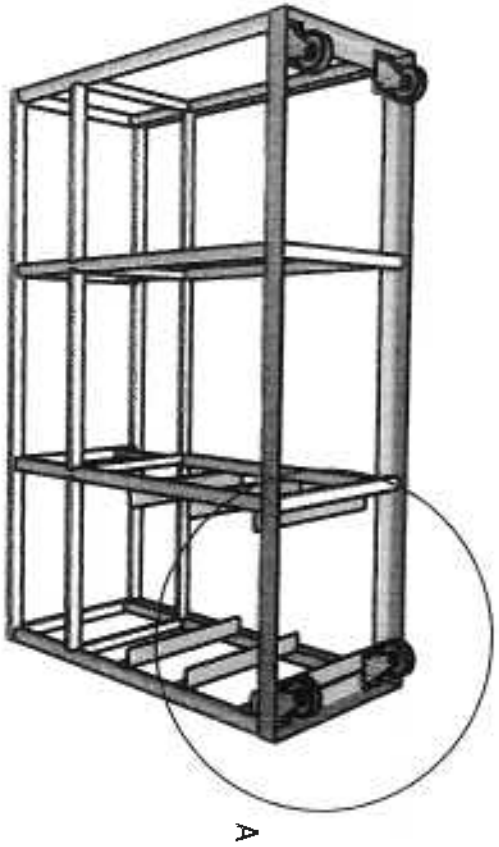

A (1 : 10)

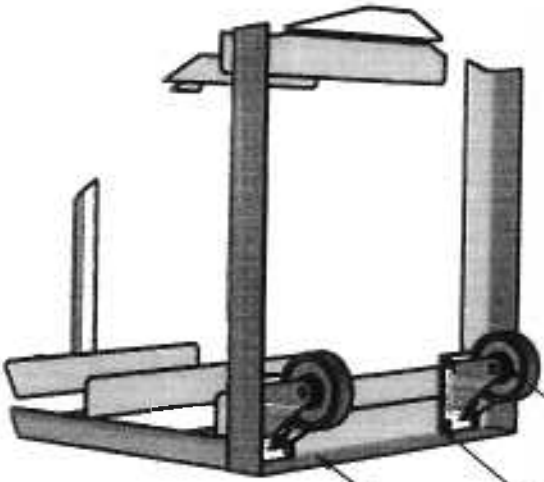

4 pcs. of 4" polyurethane roller wheels
with top plate bearing and self-locking;
load capacity: 125 lbs. per wheel

Welded in 4" x 4" x 5 mm metal plate

2" x 2" x 3/16" bar, painted



TECHNICAL
EDUCATION AND
SKILLS
DEVELOPMENT
AUTHORITY

PROJECT TITLE:
**MOBILE TRAINING
LABORATORY**

1/

DRAWN BY: J.A.

Scale: 1:20

No. of No. 1/

2 of parts

DETAIL F: RUBBER DOOR SEAL

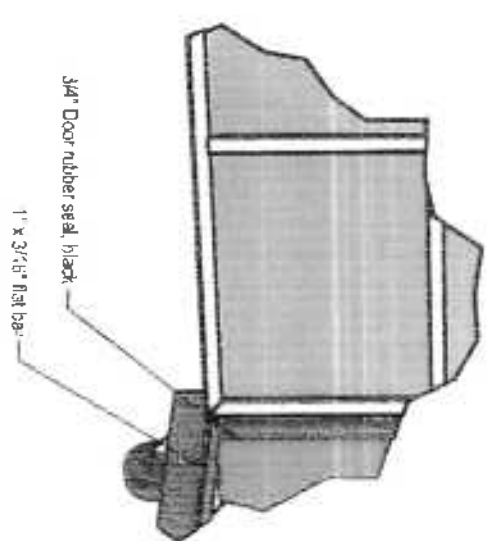
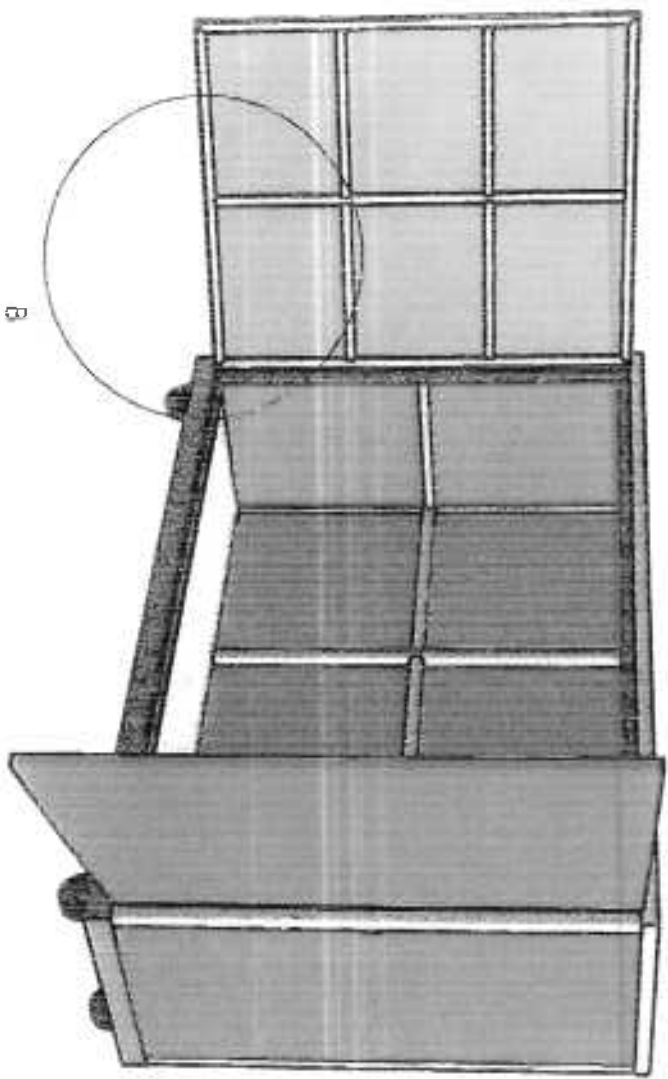

B (1:10)

3/4" Door rubber seal, black
 1" x 3/4" flat bar

B
7
ap



TECHNICAL
 EDUCATION AND
 SKILLS
 DEVELOPMENT
 AUTHORITY

PROJECT TITLE
 MOBILE TRAINING
 LABORATORY

DRAWN BY: SA
 SCALE: 1:20
 DATE: 1/11

M

| MTL BOX COVER FRAME, SIDEWAY SWING | | | |
|------------------------------------|------------------------------|-------------|------|
| NO. | MATERIAL | LENGTH, mm | Qty. |
| 1 | Gauge #18 G.I. sheet | 1,009 x 835 | 2 |
| 2 | 1" x 1" x 1.5 mm square tube | 968.25 | 4 |
| 3 | 1" x 1" x 1.5 mm square tube | 928.25 | 2 |
| 4 | 1" x 1" x 1.5 mm square tube | 793.65 | 4 |
| 5 | 1" x 1" x 1.5 mm square tube | 369.825 | 8 |
| 6 | 2" x 2mm piano hinge | 968 | 2 |
| TOTAL | | | 22 |

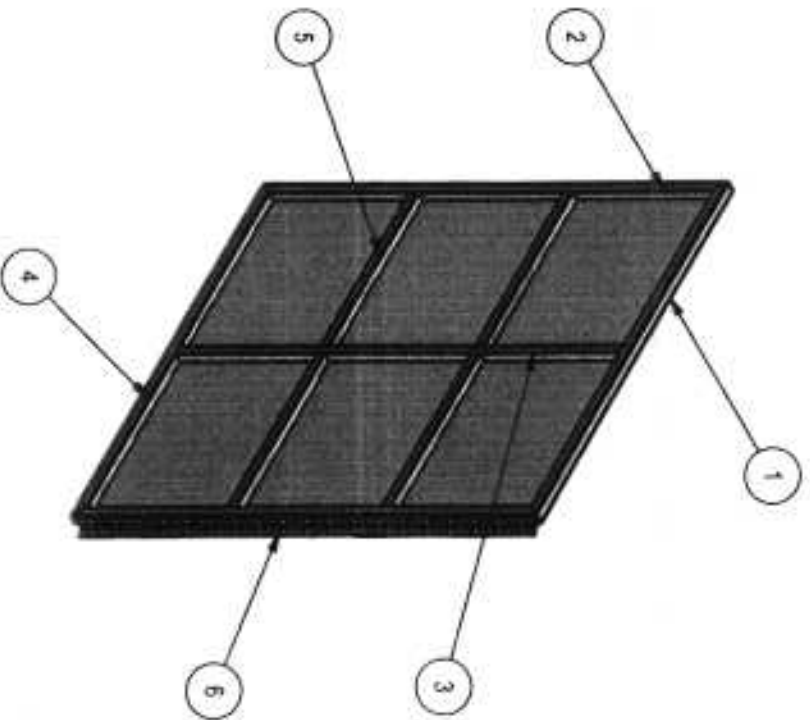

MTL DOOR FRAME

| | | | |
|---|-------------------------------|-------|-----------|
|  <p>TECHNICAL EDUCATION AND SKILLS DEVELOPMENT AUTHORITY</p> | PROJECT TITLE | Scale | Sheet No. |
| | MOBILE TRAINING LABORATORY | 1:15 | 1/ |

Handwritten signature and initials

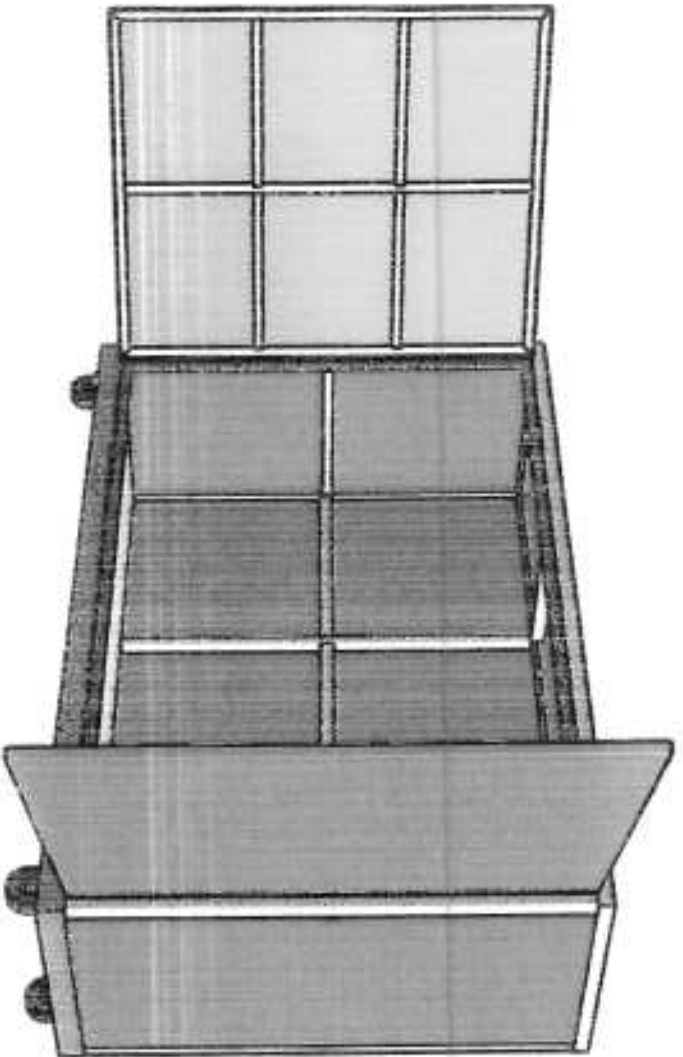

Include 2-sides metal handle
and lock with padlock for the
door (not shown in the drawing)

B 1 of 9



TECHNICAL
EDUCATION AND
SKILLS
DEVELOPMENT
AUTHORITY

| | | | |
|---------------|-------------------------------|------|----|
| PROJECT TITLE | MOBILE TRAINING LABORATORY | DATE | 11 |
| VERSION | 1.0 | DATE | 11 |

COMPARATIVE TECHNICAL SPECIFICATION

| TESDA'S SPECIFICATIONS | | BIDDER'S SPECIFICATIONS | |
|------------------------|--|--------------------------------------|------------------------------------|
| No. | Item | Specifications | Item/Brand/Model Specifications |
| Lot 5 | Electrical Installation and Maintenance NC II with Toolbox MTL Box No. 6 | Please refer to the attached drawing | |

Name of Bidder: _____

Name and Signature of Authorized Representative: _____
 Position/Designation: _____
 Date: _____

Handwritten marks:
 ✓
 JPS
 JPS

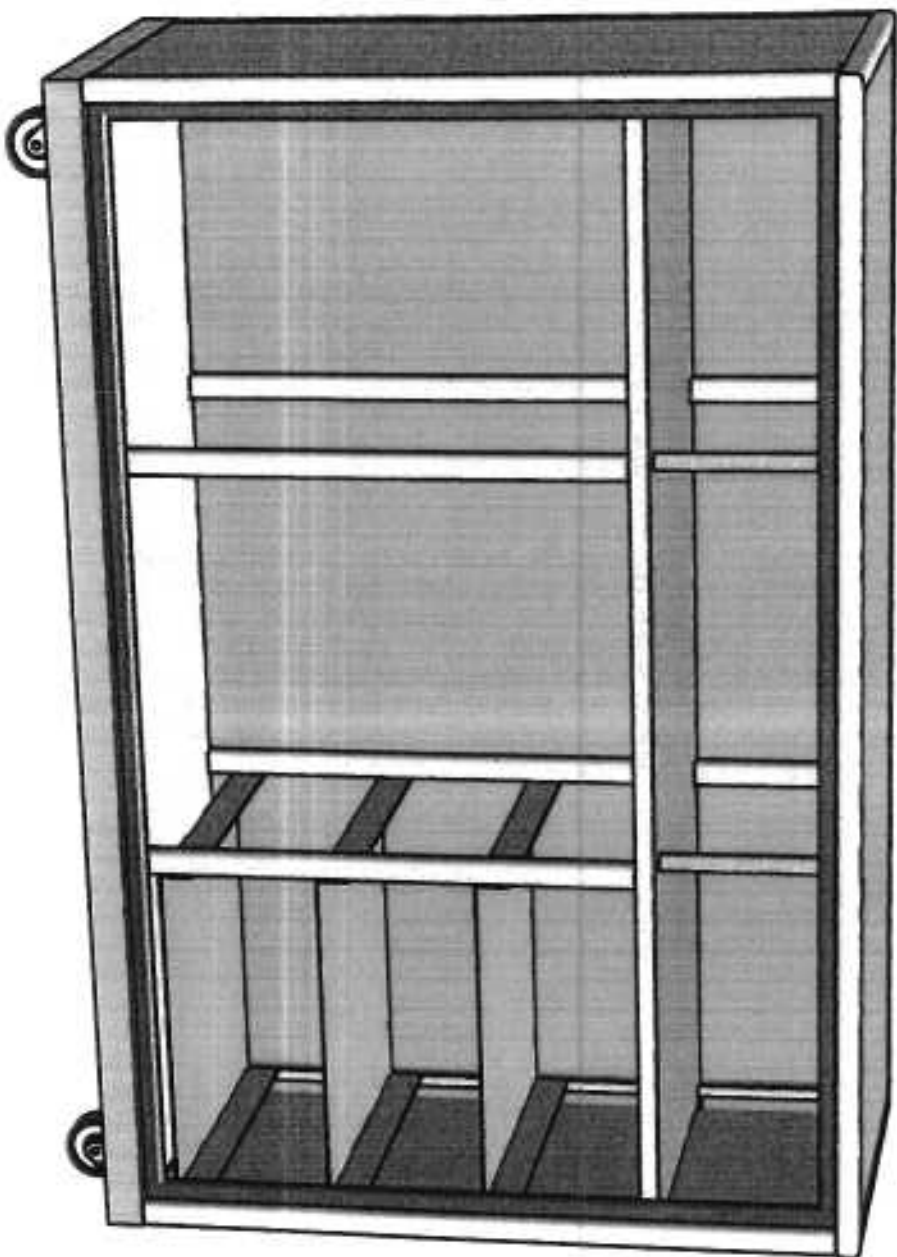

MTL BOX NO. 6
(EIM)
QUANTITY:
 (The door is not shown in the drawing)

PRODUCED BY AN AUTODESK EDUCATIONAL PRODUCT



TECHNICAL
 EDUCATION AND
 SKILLS
 DEVELOPMENT
 AUTHORITY

PROJECT TITLE
**MOBILE TRAINING
 LABORATORY**

DRAWN BY: JSA

Scale: 1:11

Sheet No. 1 /

2

2

| MTL BOX 6 FRAME | | | |
|-----------------|--|------------|------|
| NO. | MATERIAL | LENGTH, mm | Qty. |
| 1 | 2" x 2" x 3/16" angle bar | 1,600.00 | 2 |
| 2 | 2" x 2" x 3/16" angle bar | 500.00 | 2 |
| 3 | 1 1/4" x 1 1/4" x 2 mm square tube | 493.65 | 2 |
| 4 | 1 1/4" x 1 1/4" x 2 mm square tube | 968.25 | 6 |
| 5 | 1 1/4" x 1 1/4" x 2 mm square tube | 1,600.00 | 2 |
| 6 | 1 1/4" x 1 1/4" x 2 mm square tube | 500.00 | 2 |
| 7 | 1 1/4" x 1 1/4" x 2 mm square tube | 436.50 | 2 |
| 8 | 1 1/4" x 1 1/4" x 2 mm square tube | 1,473.00 | 1 |
| 9 | 1 1/4" x 1 1/4" x 2 mm square tube | 695.00 | 2 |
| 10 | 1" x 1" x 1.5 mm square tube | 393.25 | 2 |
| 11 | 1" x 1" x 1.5 mm square tube | 392.04 | 2 |
| 12 | 1" x 1" x 1.5 mm square tube | 1,536.50 | 1 |
| 13 | 1" x 1" x 1.5 mm square tube | 968.25 | 2 |
| 14 | Gauge #18 G sheet, 2" x 2" @ 90 degrees bend | 431.70 | 6 |
| 15 | 3/4" x 3/4" x 1.5 mm square tube | 247.04 | 2 |
| TOTAL | | | 36 |

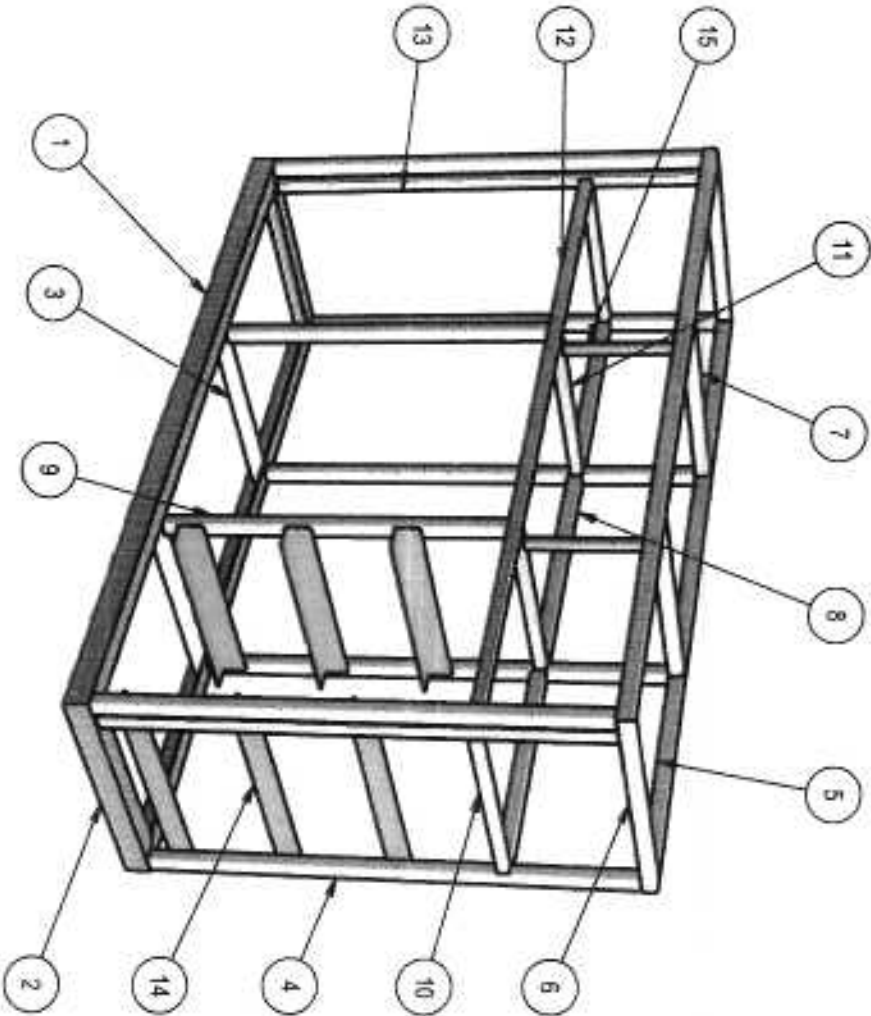

MTL BOX NO. 6 FRAME (EIM)
 (The door is not shown in the drawing)



TECHNICAL EDUCATION AND SKILLS DEVELOPMENT AUTHORITY

PROJECT TITLE
MOBILE TRAINING LABORATORY

DRAWN BY: JJA

Scale: 1:15

1 /

JJA
1/15
off

MTL BOX NO. 6

- ⊕ All materials must be painted with anti-corrosive primer
- ⊠ Tube and bar are coated with light gray epoxy finish paint

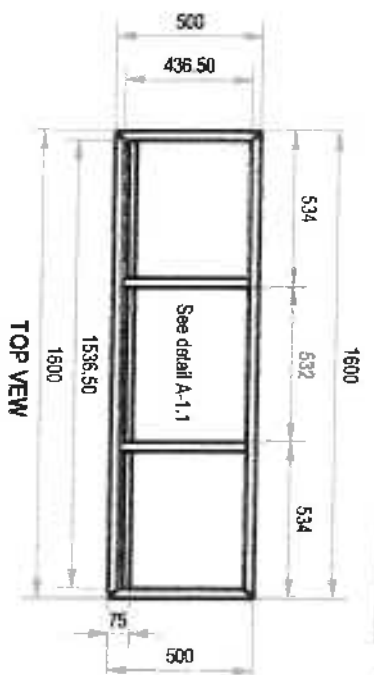

TOP VIEW

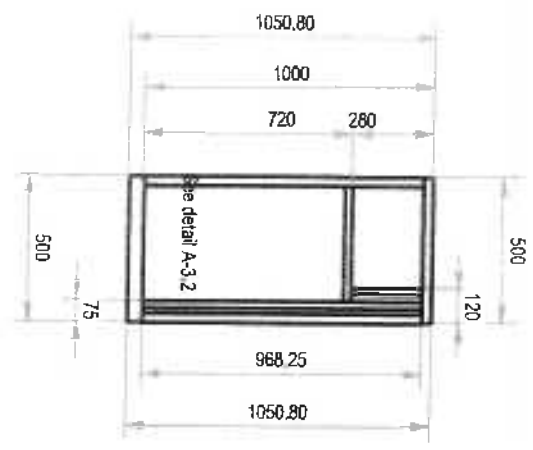

LEFT SIDE VIEW



FRONT VIEW

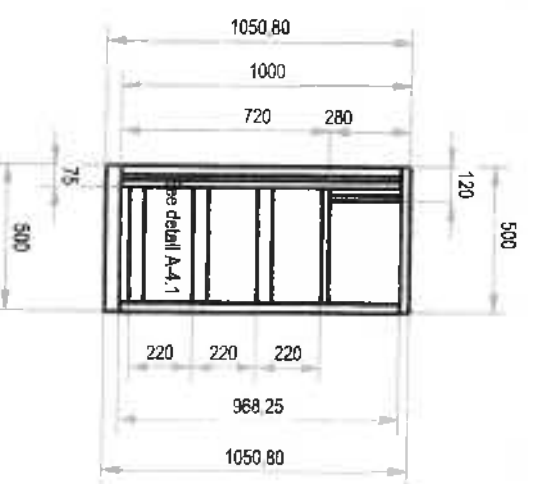

RIGHT SIDE VIEW

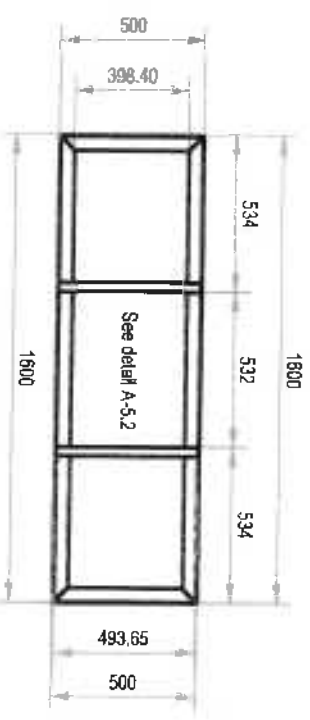

BOTTOM VIEW

MTL BOX NO. 6 FRAME
(EIM)
 (The door is not shown in the drawing)



TECHNICAL EDUCATION AND SKILLS DEVELOPMENT AUTHORITY

PROJECT TITLE
MOBILE TRAINING LABORATORY

DRAWN BY: JH **Scale: 1:25** **Sheet No: 1/1**

DETAIL A-1.1:

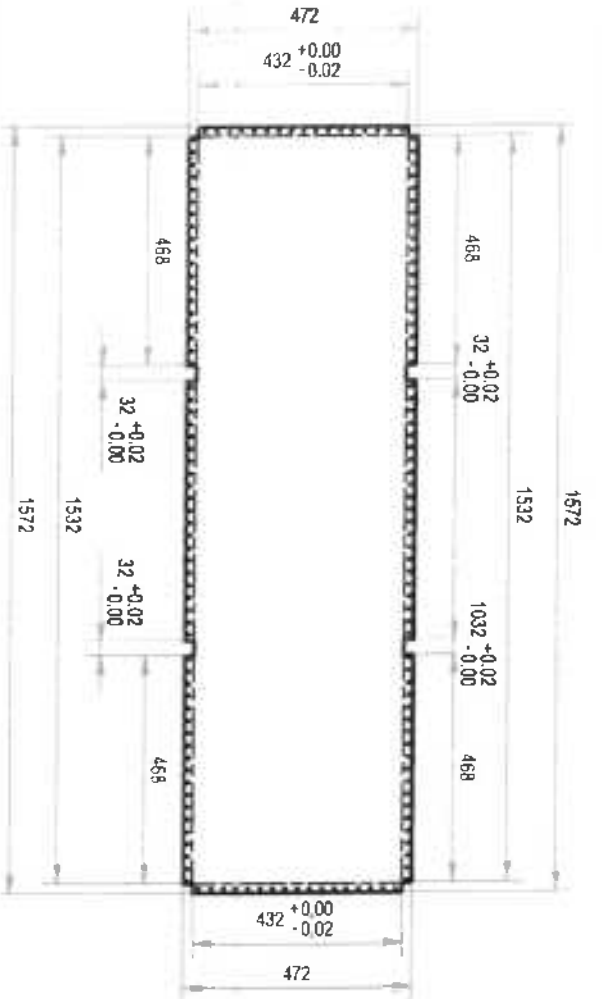

QUANTITY: 5

DETAIL A-1.2:

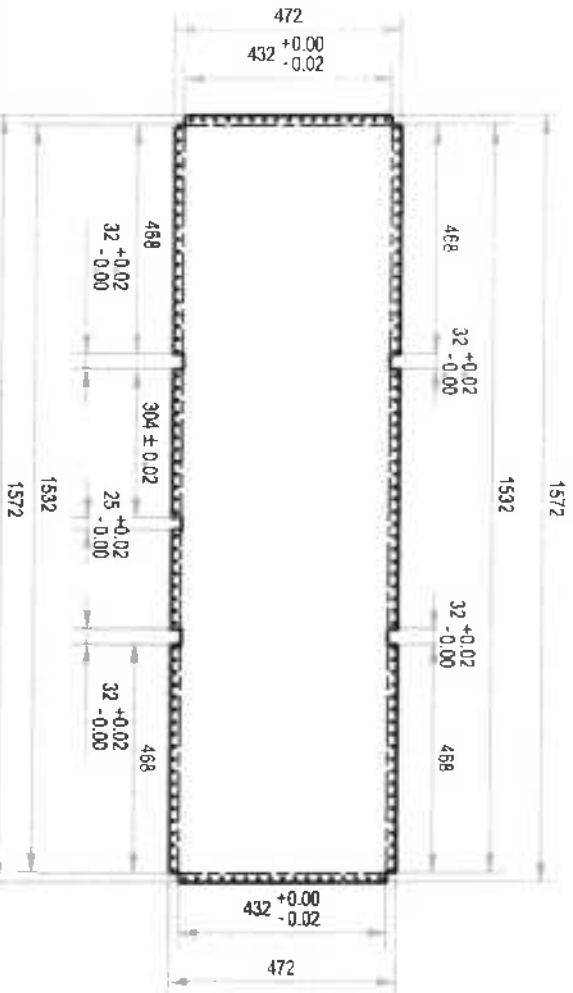

QUANTITY: 2

FLAT PATTERN: GALVANIZED SHEET GAUGE #18, PAINTED

DETAIL A-1.3:

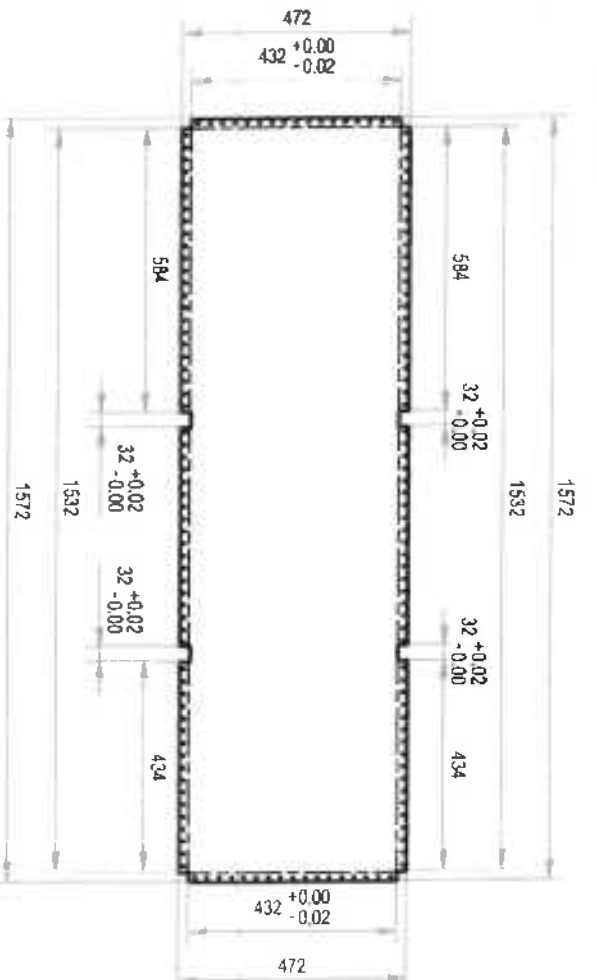

QUANTITY: 1

DETAIL A-1.4:

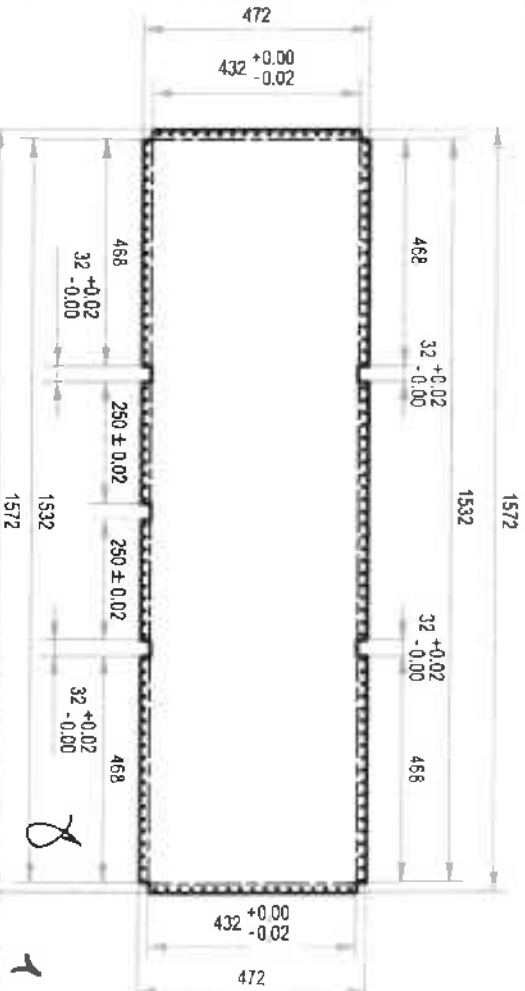

QUANTITY: 2

Use 3/16" blind rivet spaced @ 1" O.C.



TECHNICAL
EDUCATION AND
SKILLS
DEVELOPMENT
AUTHORITY

PROJECT TITLE
**MOBILE TRAINING
LABORATORY**

DRAWN BY: JPA
Scale: 1:15
Sheet No: 1/

DETAIL A-3.1:

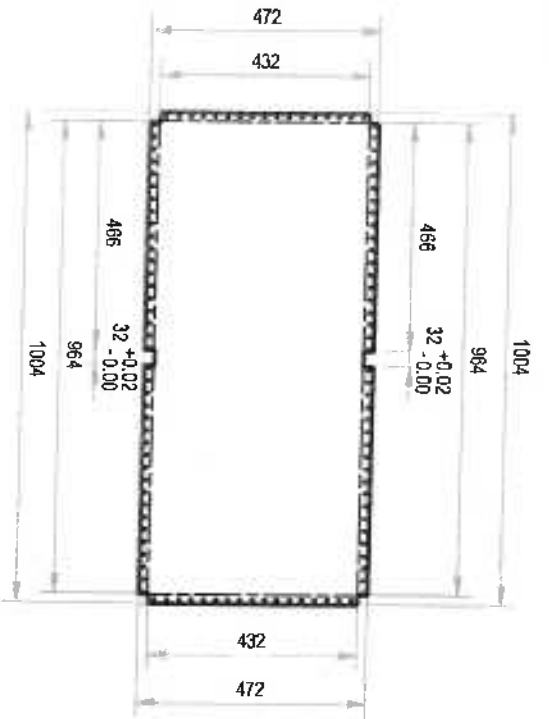

QUANTITY: 5

DETAIL A-3.2:

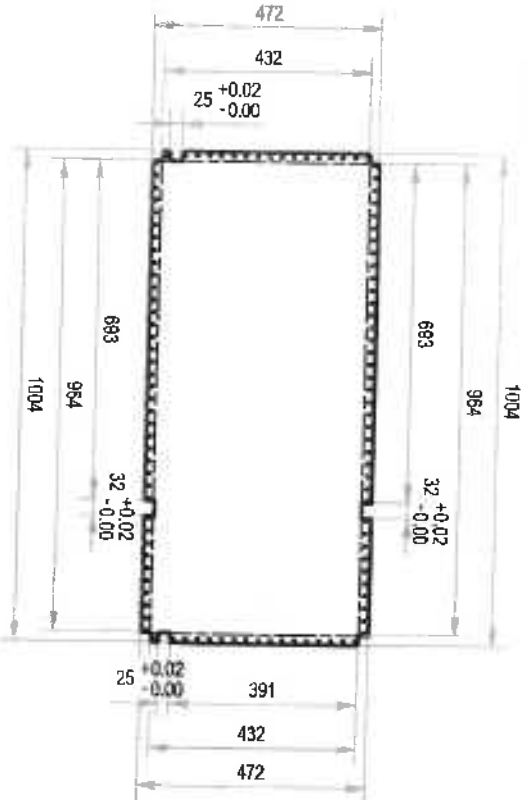

QUANTITY: 4

FLAT PATTERN: GALVANIZED SHEET GAUGE #18, PAINTED

DETAIL A-3.3:

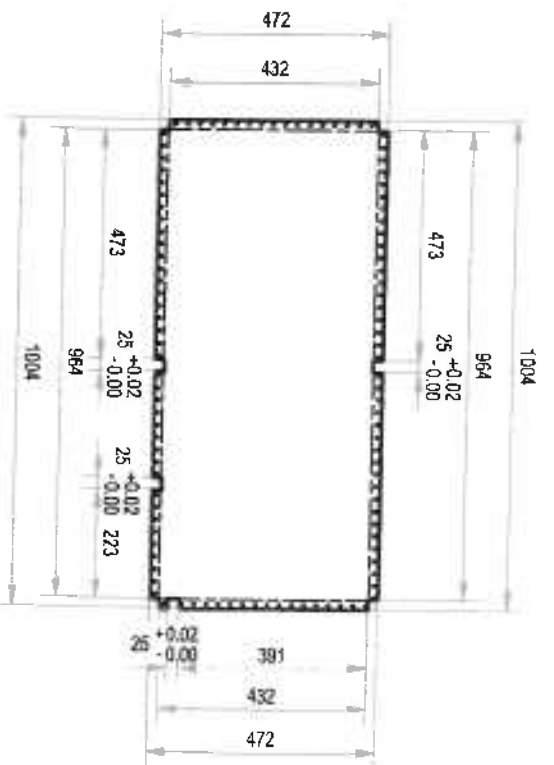

QUANTITY: 1

DETAIL A-3.4:

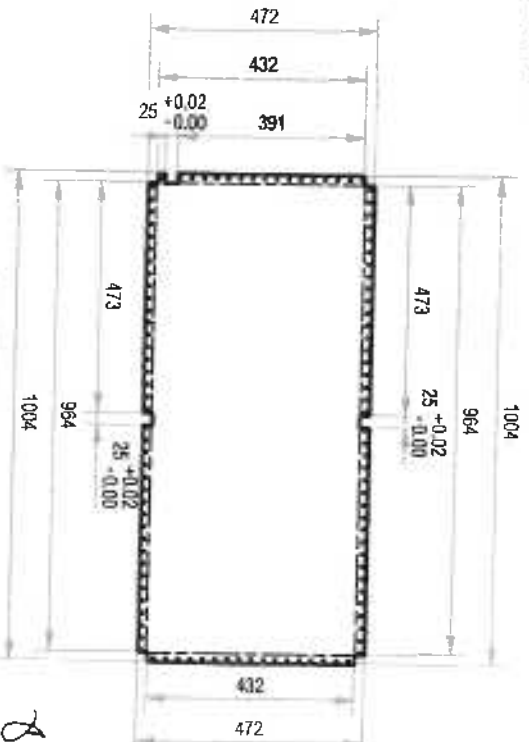

QUANTITY: 2

Use 3/16" blind rivet spaced @ 1" O.C.



TECHNICAL EDUCATION AND SKILLS DEVELOPMENT AUTHORITY

PROJECT TITLE: MOBILE TRAINING LABORATORY

DRAWING NO. JSA

Scale: 1:15

Sheet No. 1/1

Handwritten initials and numbers: 2, 7, 1, 2

DETAIL A-4.1:

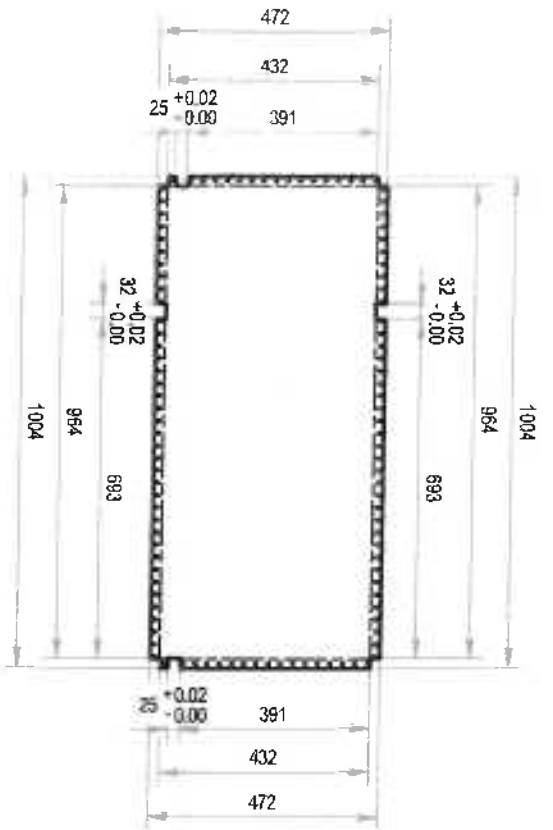

QUANTITY: 4

DETAIL A-4.2:

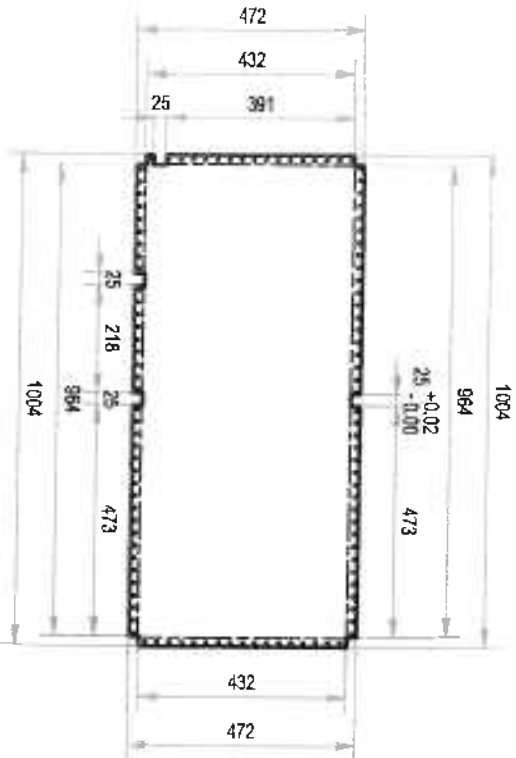

QUANTITY: 2

DETAIL A-4.3:

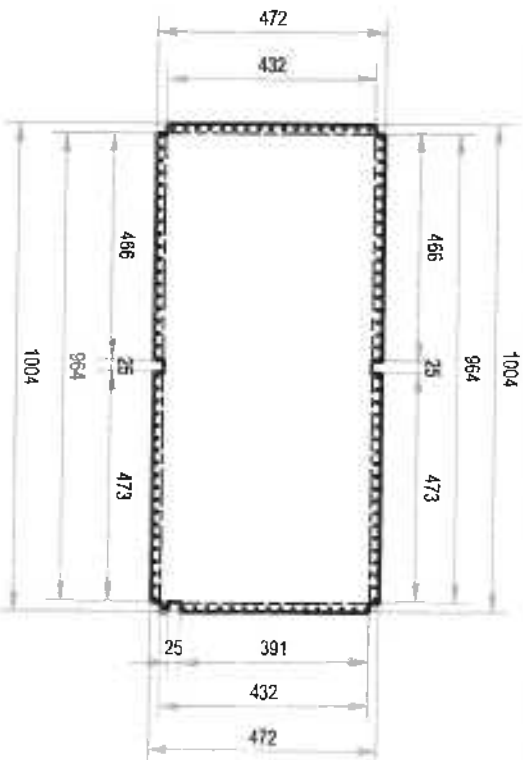

QUANTITY: 2

FLAT PATTERN: GALVANIZED SHEET GAUGE #18, PAINTED

Use 3/16" blind rivet spaced @ 1" O.C.



TECHNICAL EDUCATION AND SKILLS DEVELOPMENT AUTHORITY

PROJECT TITLE
MOBILE TRAINING LABORATORY

DRAWN BY: JVA

SCALE: 1:15

Sheet No. 1/1

Handwritten initials and marks, including a large '2' and a signature.

DETAIL A-5.1:

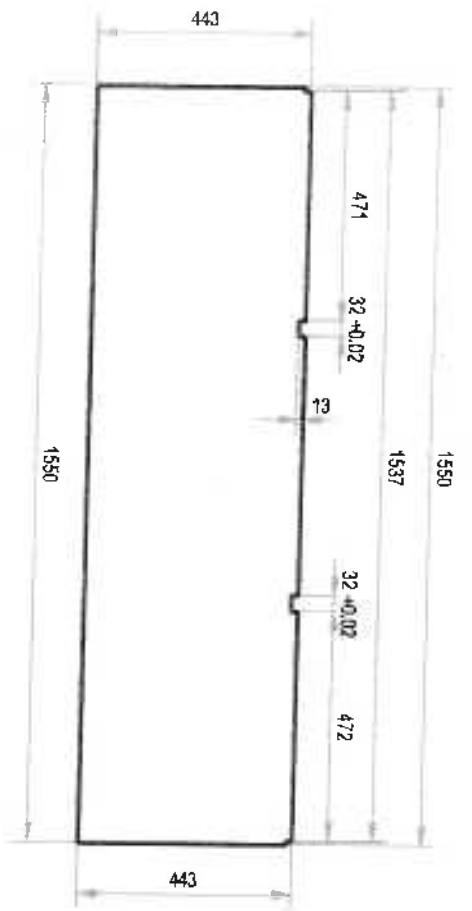

QUANTITY: 1

DETAIL A-5.3:

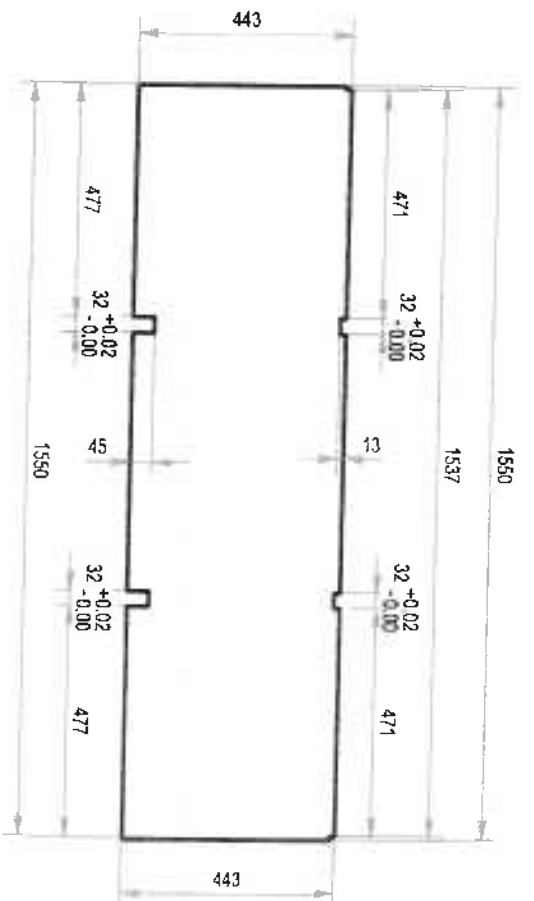

QUANTITY: 2

DETAIL A-5.2:

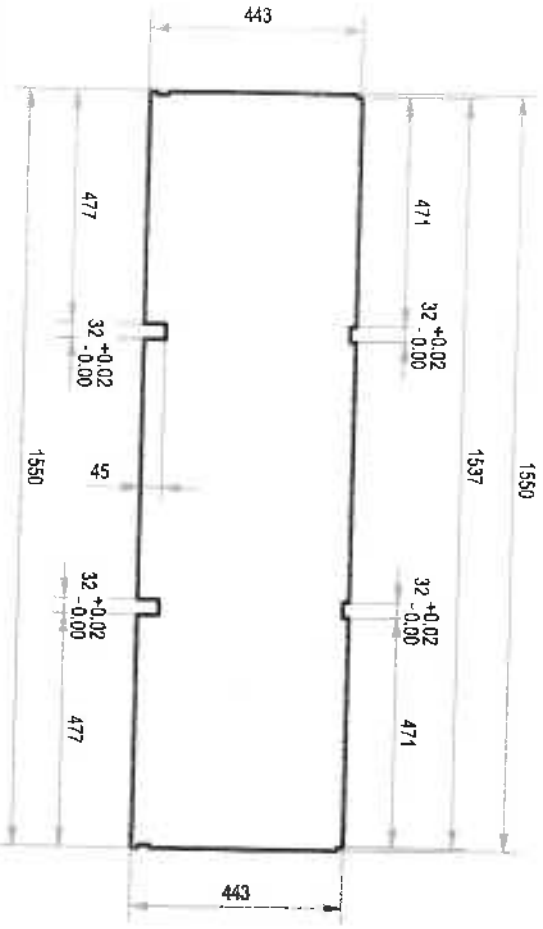

QUANTITY: 6

GALVANIZED SHEET GAUGE #18, PAINTED

DETAIL A-5.4:

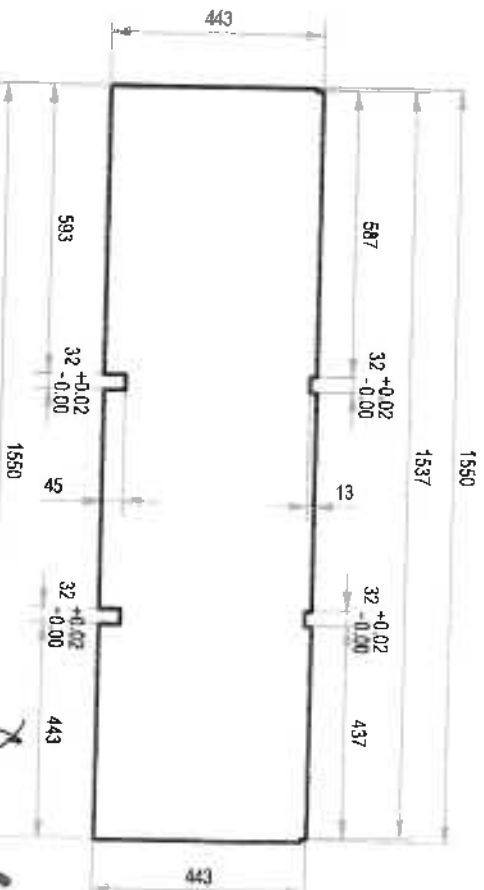

QUANTITY: 1

PRODUCED BY AN AUTODESK EDUCATIONAL PRODUCT



TECHNICAL
EDUCATION AND
SKILLS
DEVELOPMENT
AUTHORITY

PROJECT TITLE
**MOBILE TRAINING
LABORATORY**

DRAWN BY: JKA

Scale: 1:15

Sheet No. 1/1

Handwritten initials and marks

DETAIL B-1.1:

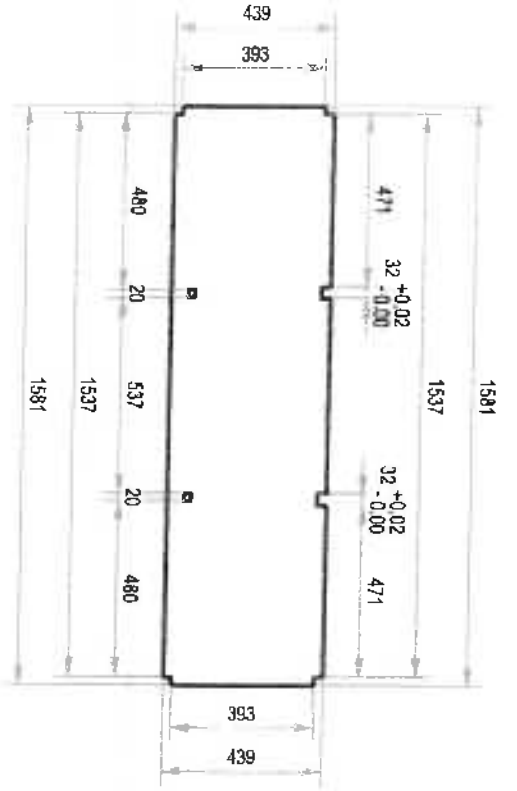

QUANTITY: 2

DETAIL B-1.3:

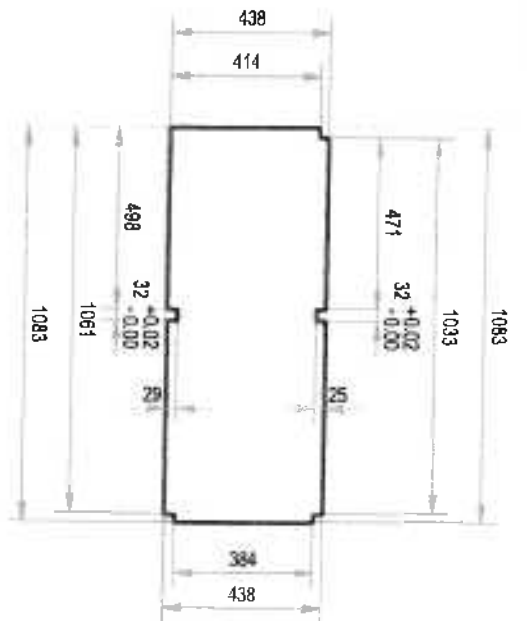

QUANTITY: 1

DETAIL B-1.4:

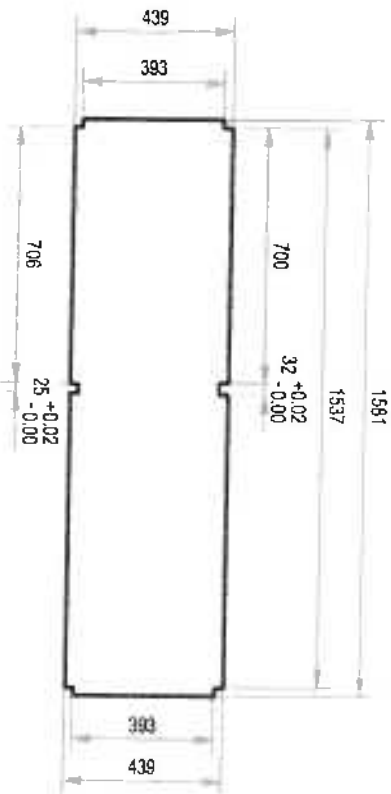

QUANTITY: 1

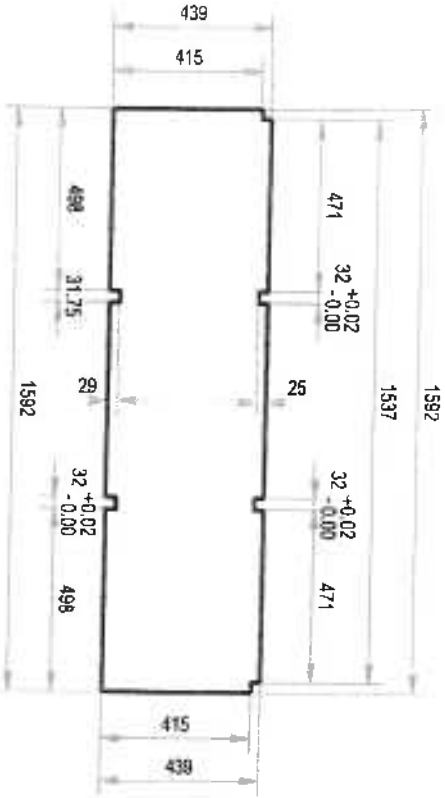

GALVANIZED SHEET GAUGE #18, PAINTED

QUANTITY: 2

PRODUCED BY AN AUTODESK EDUCATIONAL PRODUCT



TECHNICAL EDUCATION AND SKILLS DEVELOPMENT AUTHORITY

PROJECT TITLE
MOBILE TRAINING LABORATORY

NUMBER: J-4

Scale: 1:20

Sheet No: 1 /

DETAIL C-1.1:

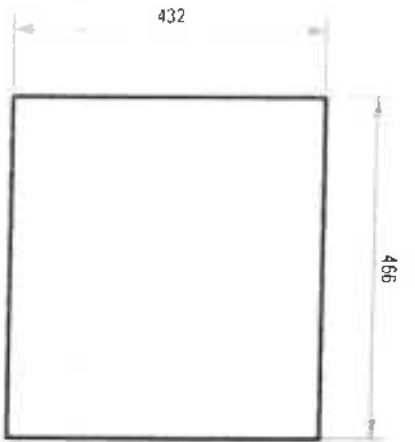

QUANTITY: 15

DETAIL C-1.2:

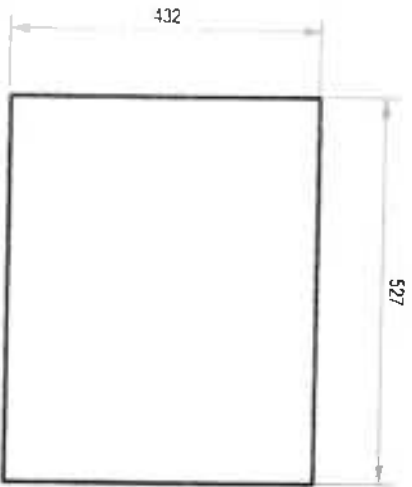

QUANTITY: 9

DETAIL C-1.3:

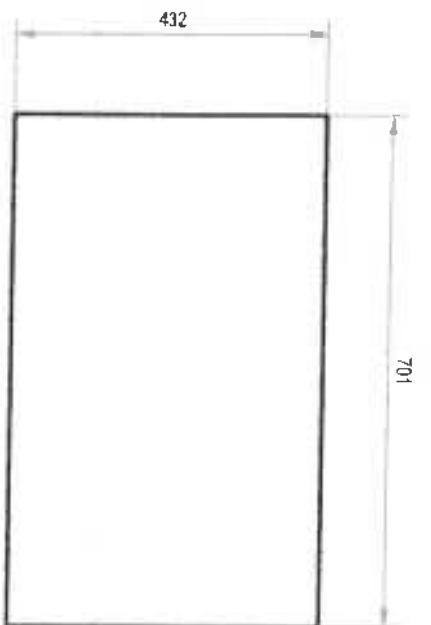

QUANTITY: 2

DETAIL D-1.1:

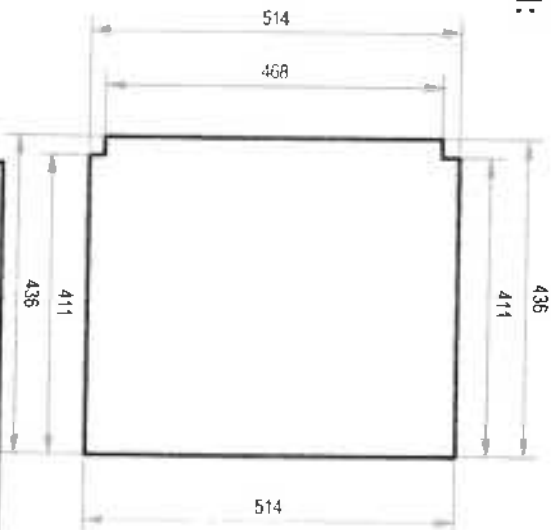

QUANTITY: 1

GALVANIZED SHEET GAUGE #18, PAINTED

PRODUCED BY AN AUTODESK EDUCATIONAL PRODUCT



TECHNICAL
EDUCATION AND
SKILLS
DEVELOPMENT
AUTHORITY

PROJECT TITLE
**MOBILE TRAINING
LABORATORY**

DRAWN BY: JVA

Scale: 1:10

Sheet No: 1/1

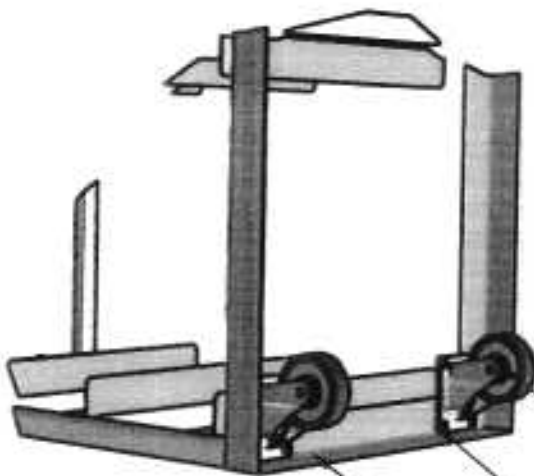

A (1 : 10)

4 pcs. of 4" polyurethane roller wheels
with top plate bearing and self-locking;
load capacity: 125 lbs. per wheel

Welded in 4" x 4" x 5 mm metal plate

2" x 2" x 3/16" \angle bar, painted



TECHNICAL
EDUCATION AND
SKILLS
DEVELOPMENT
AUTHORITY

PROJECT TITLE
**MOBILE TRAINING
LABORATORY**

DESIGNED BY JSA

Scale 1:20

Sheet No.
1 /

DETAIL F: RUBBER DOOR SEAL

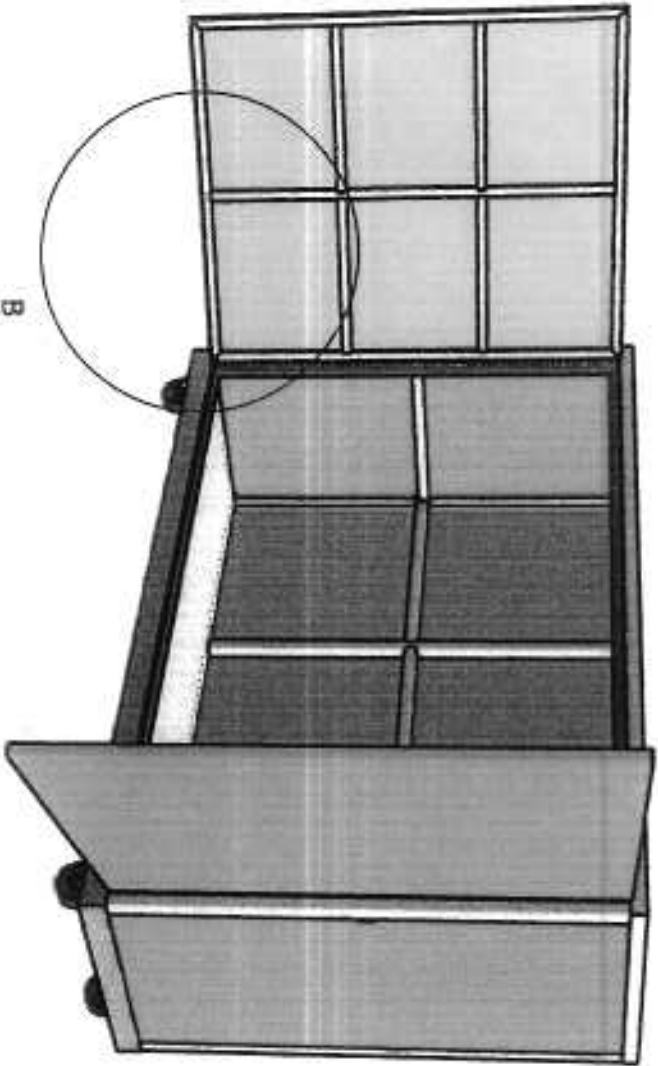

B (1:10)

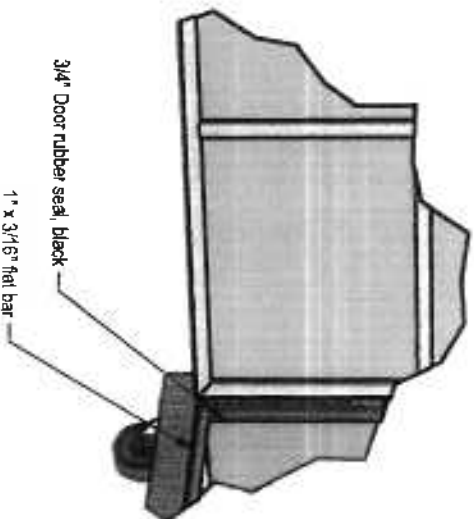

TECHNICAL
EDUCATION AND
SKILLS
DEVELOPMENT
AUTHORITY

PROJECT TITLE
**MOBILE TRAINING
LABORATORY**

Drawn By: JJA

Scale: 1:25

Sheet No:
1 /

| MTL BOX COVER FRAME, SIDEWAY SWING | | | |
|------------------------------------|------------------------------|-------------|------|
| NO. | MATERIAL | LENGTH, mm | Qty. |
| 1 | Gauge #18 G.I. sheet | 1,009 x 835 | 2 |
| 2 | 1" x 1" x 1.5 mm square tube | 968,25 | 4 |
| 3 | 1" x 1" x 1.5 mm square tube | 928,25 | 2 |
| 4 | 1" x 1" x 1.5 mm square tube | 793,65 | 4 |
| 5 | 1" x 1" x 1.5 mm square tube | 369,825 | 8 |
| 6 | 2" x 2mm piano hinge | 968 | 2 |
| TOTAL | | | 22 |

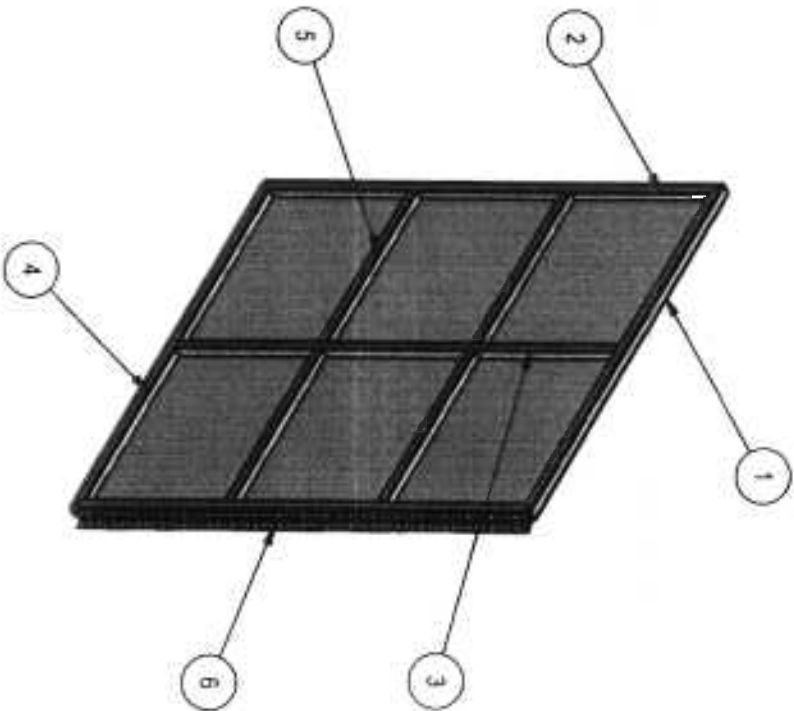

MTL DOOR FRAME

| | | | |
|--|---|---------------|-------------|
| | TECHNICAL EDUCATION AND SKILLS DEVELOPMENT AUTHORITY | | |
| | PROJECT TITLE MOBILE TRAINING LABORATORY | DRAWN BY: 094 | Scale: 1/15 |

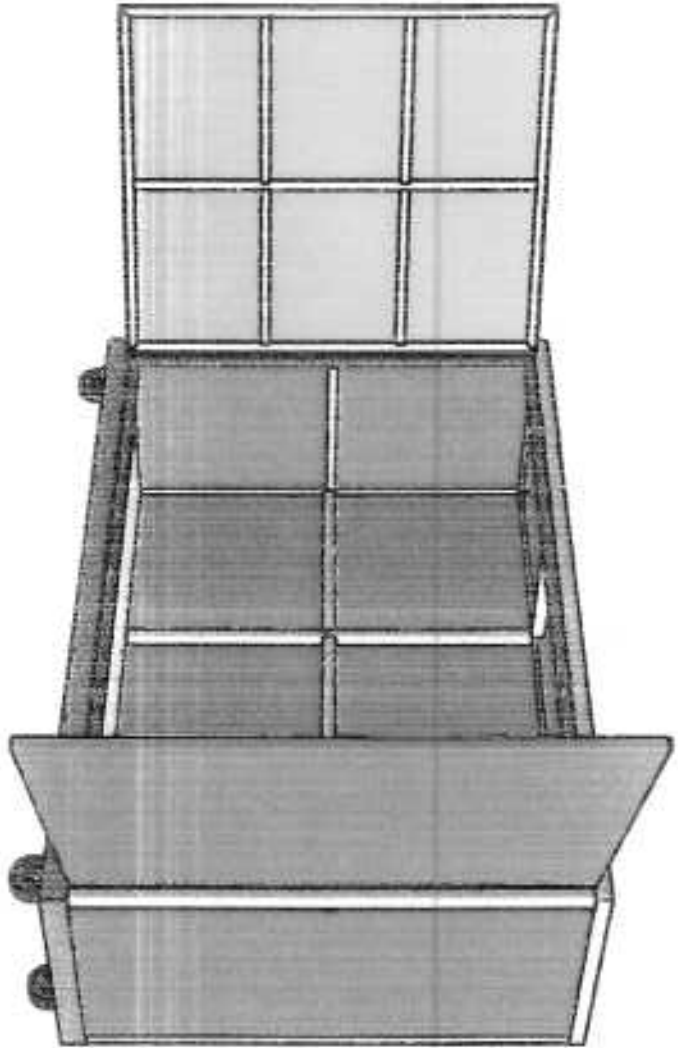

Include 2-sides metal handle
and lock with padlock for the
door (not shown in the drawing)

DOWNLOADED BY AN AUTODESK EDUCATIONAL PRODUCT



TECHNICAL
EDUCATION AND
SKILLS
DEVELOPMENT
AUTHORITY

PROJECT TITLE:
MOBILE TRAINING
LABORATORY

N

Q 1

DATE: 1/1

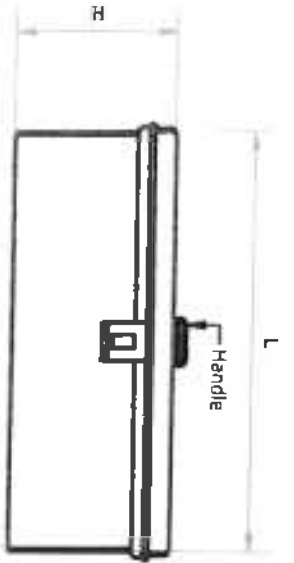

FRONT VIEW

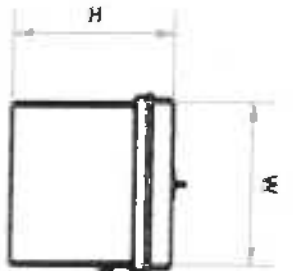

SIDE VIEW

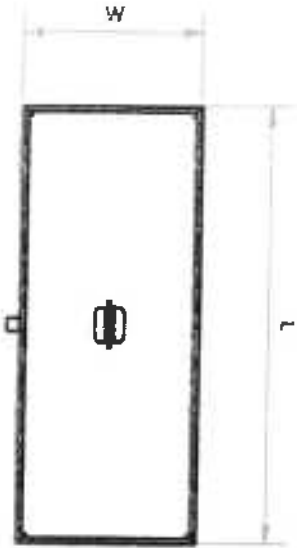

TOP VIEW

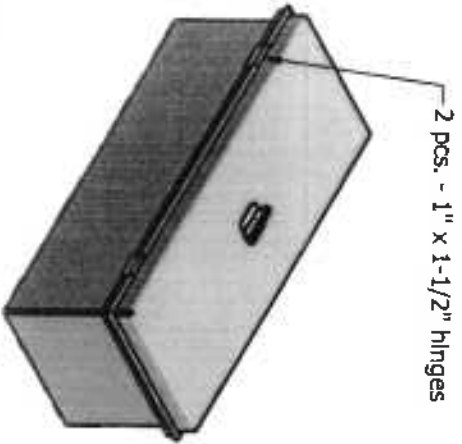

ISOMETRIC VIEW

| TOOLBOX | | | |
|---------|--------------------|--|---------------------|
| NO. | DIMENSION (L x | MATERIAL | NO. OF PCS. PER SET |
| 1 | 18" x 7" x 7" | Small Engine Repair - G.A. #18 galvanized sheet, painted | 12 |
| 3 | 18" x 7" x 8" | Appliance Repair - G.A. #18 galvanized sheet, painted | 6 |
| | 18" x 7" x 8" | Electrical Installation and Maintenance - G.A. #18 galvanized sheet, painted | 6 |
| 4 | 20" x 7" x 8" | Small Engine Repair - G.A. #18 galvanized sheet, painted | 6 |
| 5 | 16" x 20" x 4-1/2" | Cookery - Plastic, white | 3 |
| 6 | 16" x 20" x 4-1/2" | Food Processing - Plastic, white | 3 |



COMPARATIVE TECHNICAL SPECIFICATION

| TESDA'S SPECIFICATIONS | | BIDDER'S SPECIFICATIONS | | |
|------------------------|---|--------------------------------------|------------------|----------------|
| No. | Item | Specifications | Item/Brand/Model | Specifications |
| Lot 6 | Food Processing NC II with Plastic Box MTL Box No. 7 | Please refer to the attached drawing | | |

Name of Bidder: _____

Name and Signature of Authorized Representative: _____
 Position/Designation: _____
 Date: _____

Handwritten signature and initials

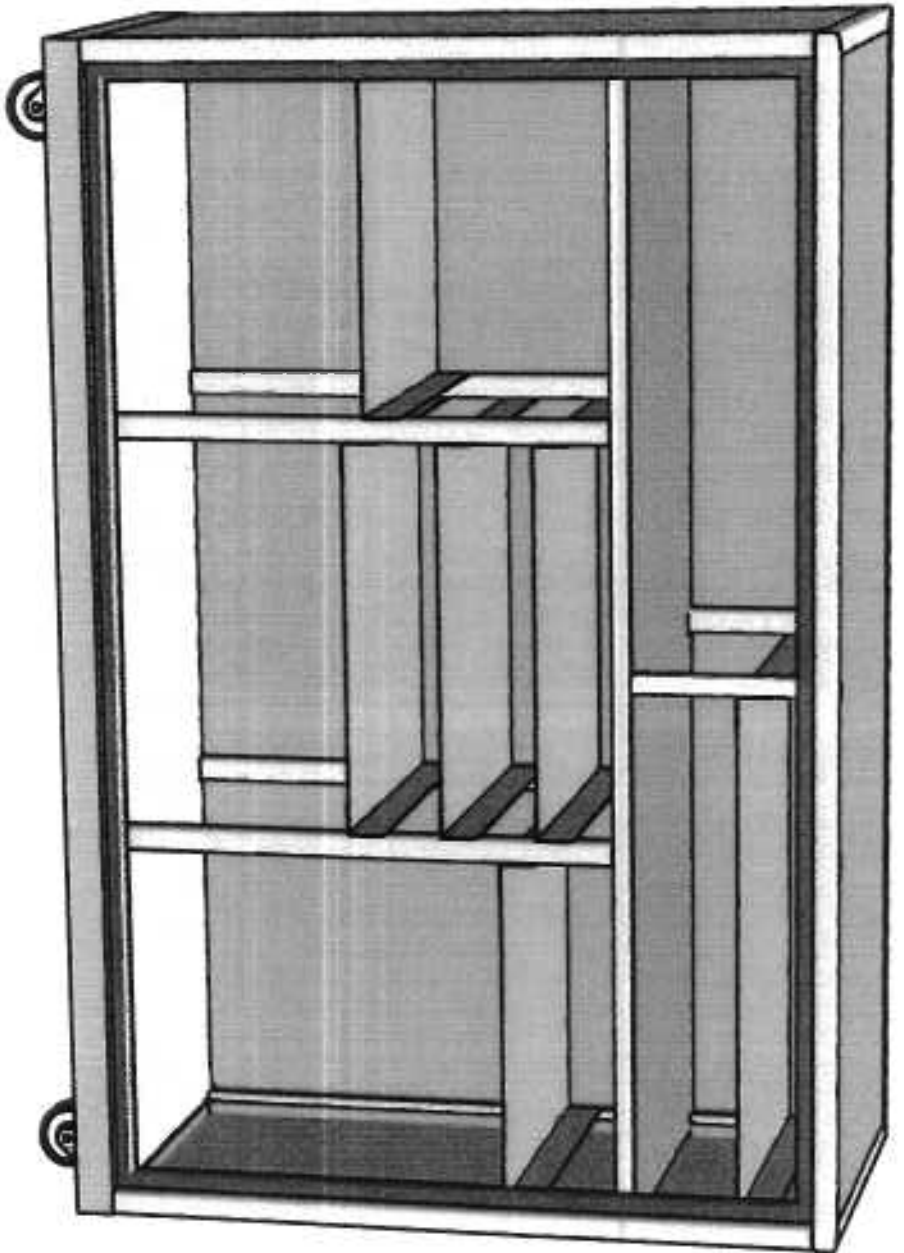

MTL BOX NO. 7
(FOOD PROCESSING)
QUANTITY:
 (The door is not shown in the drawing)

PRODUCED BY AN AUTODESK EDUCATIONAL PRODUCT



TECHNICAL
 EDUCATION AND
 SKILLS
 DEVELOPMENT
 AUTHORITY

PROJECT TITLE
**MOBILE TRAINING
 LABORATORY**

Drawn by: JAK

Scale: 1:10

Sheet No.: 1/1

8

N

| MTL BOX 7 FRAME | | | |
|-----------------|---|------------|------|
| NO. | MATERIAL | LENGTH, mm | QTY. |
| 1 | 2" x 2" x 3/16" angle bar | 1,600.00 | 2 |
| 2 | 2" x 2" x 3/16" angle bar | 500.00 | 2 |
| 3 | 1 1/4" x 1 1/4" x 2 mm square tube | 493.65 | 2 |
| 4 | 1 1/4" x 1 1/4" x 2 mm square tube | 968.25 | 4 |
| 5 | 1 1/4" x 1 1/4" x 2 mm square tube | 1,600.00 | 2 |
| 6 | 1 1/4" x 1 1/4" x 2 mm square tube | 500.00 | 2 |
| 7 | 1 1/4" x 1 1/4" x 2 mm square tube | 436.50 | 2 |
| 8 | 1 1/4" x 1 1/4" x 2 mm square tube | 1,536.50 | 1 |
| 9 | 1 1/4" x 1 1/4" x 2 mm square tube | 688.25 | 2 |
| 10 | 1 1/4" x 1 1/4" x 2 mm square tube | 895.00 | 2 |
| 11 | 1 1/4" x 1 1/4" x 2 mm square tube | 248.25 | 1 |
| 12 | 1" x 1" x 1.5 mm square tube | 1,536.50 | 1 |
| 13 | 1" x 1" x 1.5 mm square tube | 968.25 | 2 |
| 14 | 1" x 1" x 1.5 mm square tube | 383.25 | 2 |
| 15 | 1" x 1" x 1.5 mm square tube | 392.04 | 2 |
| 16 | 1" x 1" x 1.5 mm square tube | 43.25 | 1 |
| 17 | 1" x 1" x 1.5 mm square tube | 253.79 | 1 |
| 18 | Gauge #18 GI sheet 2" x 2" @ 90 degree bend | 431.70 | 12 |
| TOTAL | | | 43 |

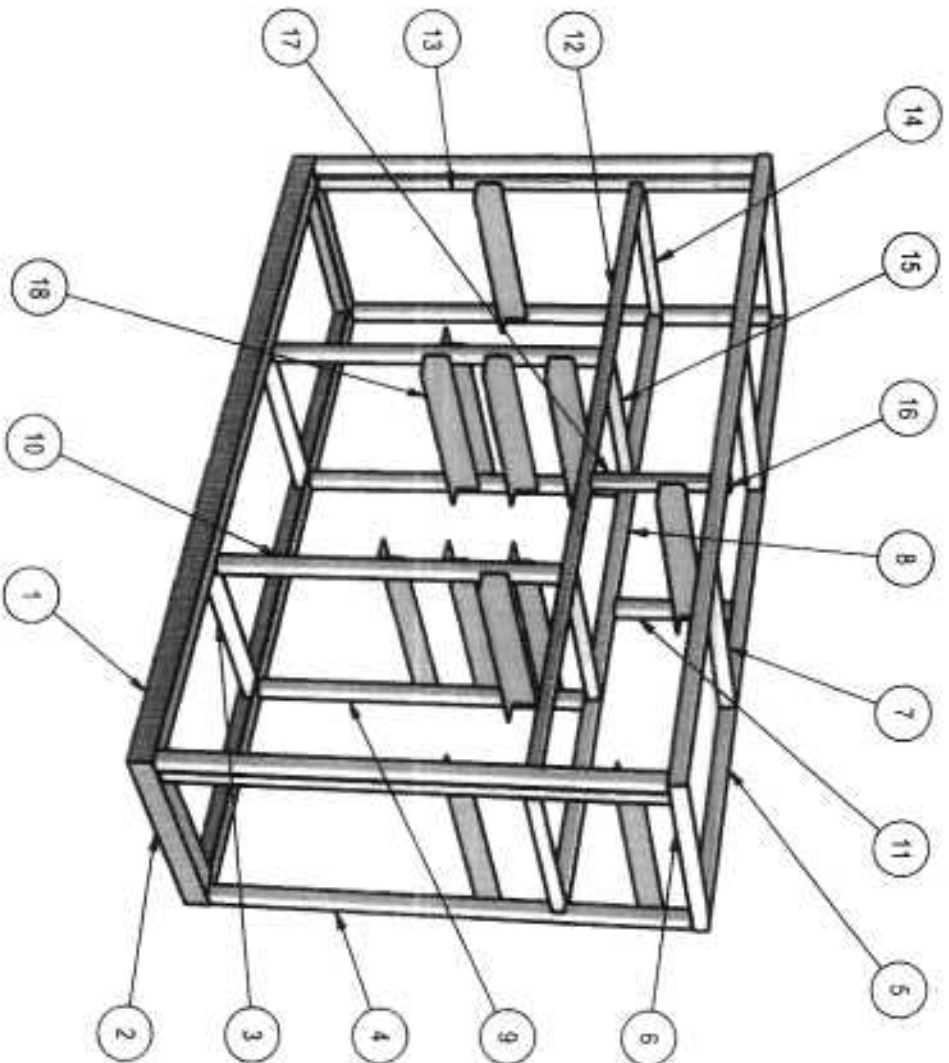

**MTL BOX NO. 7 FRAME
(FOOD PROCESSING)**
(The door is not shown in the drawing)



TECHNICAL
EDUCATION AND
SKILLS
DEVELOPMENT
AUTHORITY

PROJECT TITLE
**MOBILE TRAINING
LABORATORY**

DATE

Drawn by: J.A. Scale: 1:15 Drawing No: 1/

**MTL BOX NO. 7 FRAME
(FOOD PROCESSING)**
(The door is not shown in the drawing)

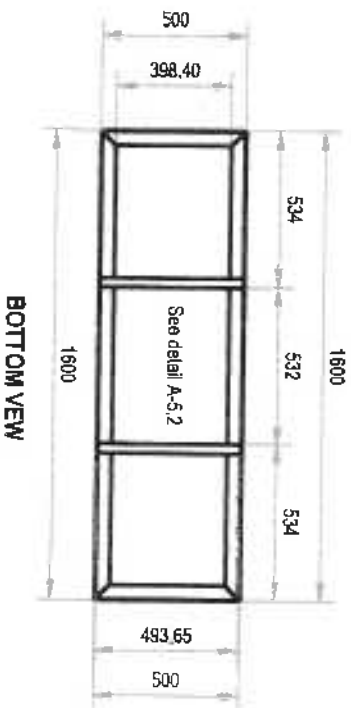
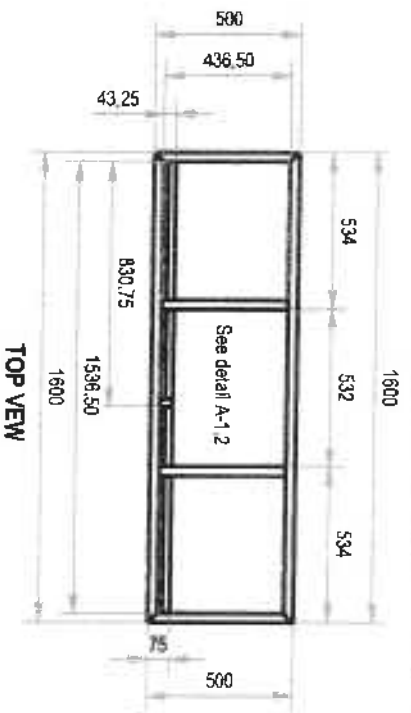
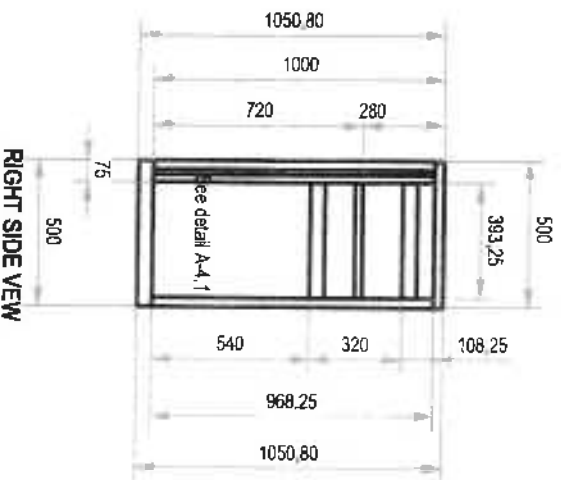
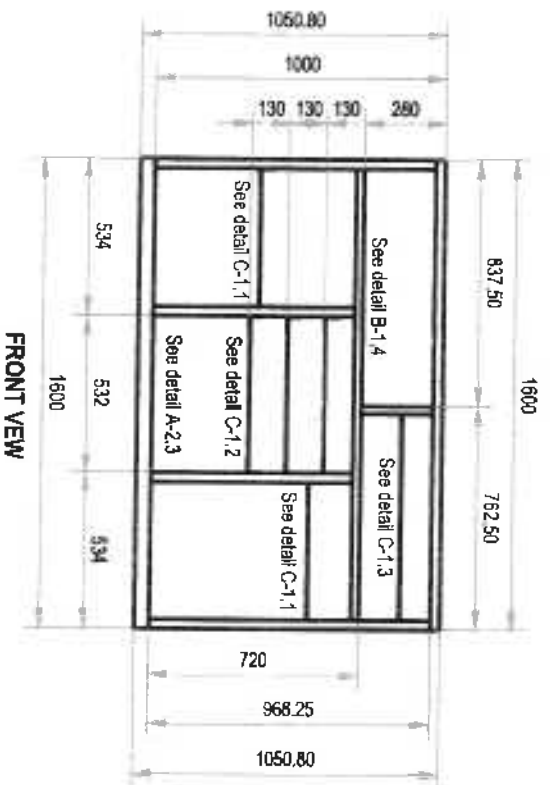
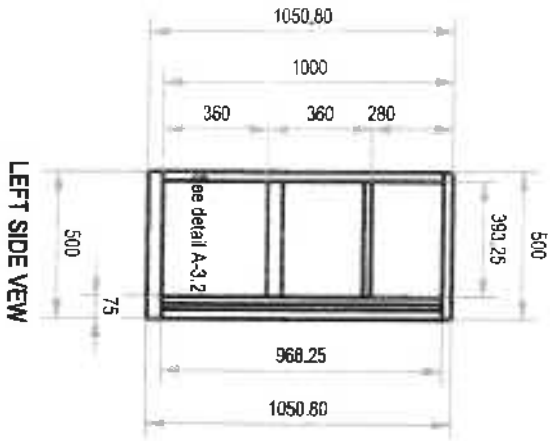

- MTL BOX NO. 7**
- ⊕ All materials must be painted with anti-corrosive primer
 - ⊕ □ Tube and < bar are coated with light gray epoxy finish paint

PRODUCED BY AN AUTODESK EDUCATIONAL PRODUCT

TECHNICAL EDUCATION AND SKILLS DEVELOPMENT AUTHORITY

PROJECT TITLE
MOBILE TRAINING LABORATORY

DRAWN BY: JPA Scale: 1:25

DETAIL A-1.1:

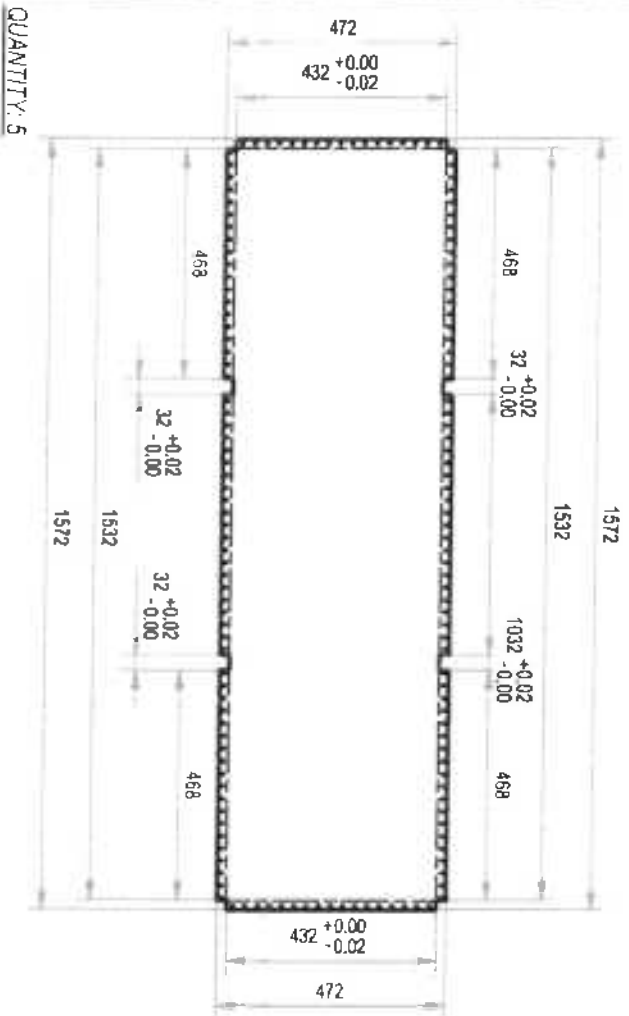

QUANTITY: 5

DETAIL A-1.3:

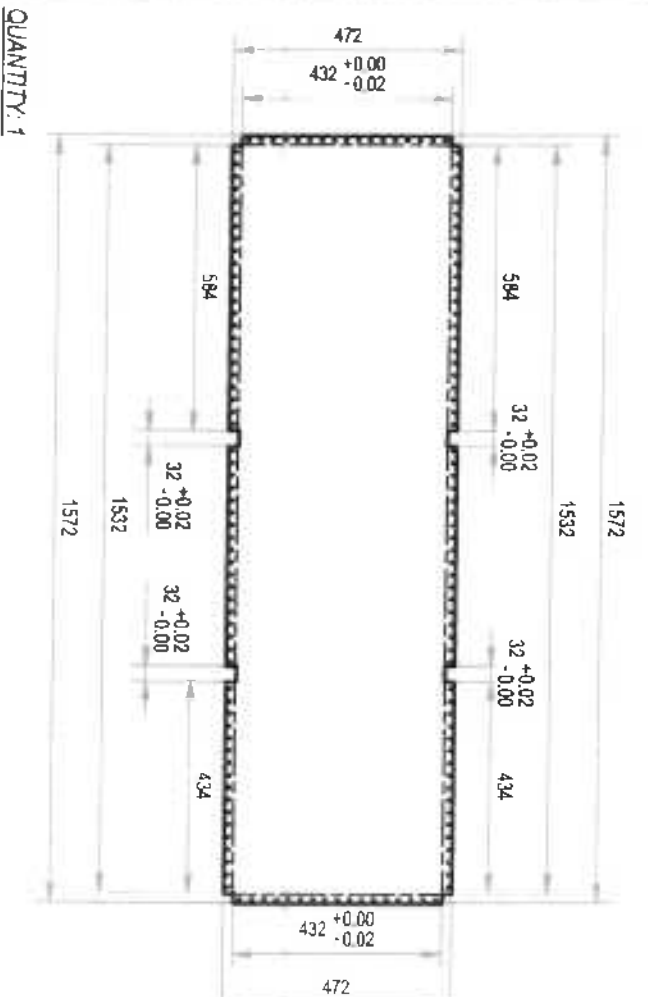

QUANTITY: 1

DETAIL A-1.2:

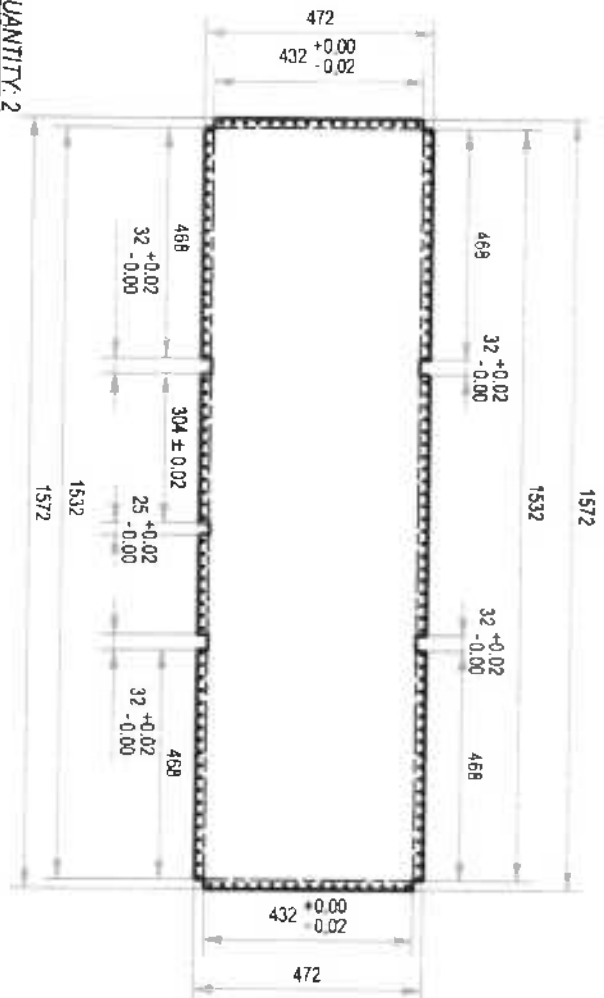

QUANTITY: 2

DETAIL A-1.4:

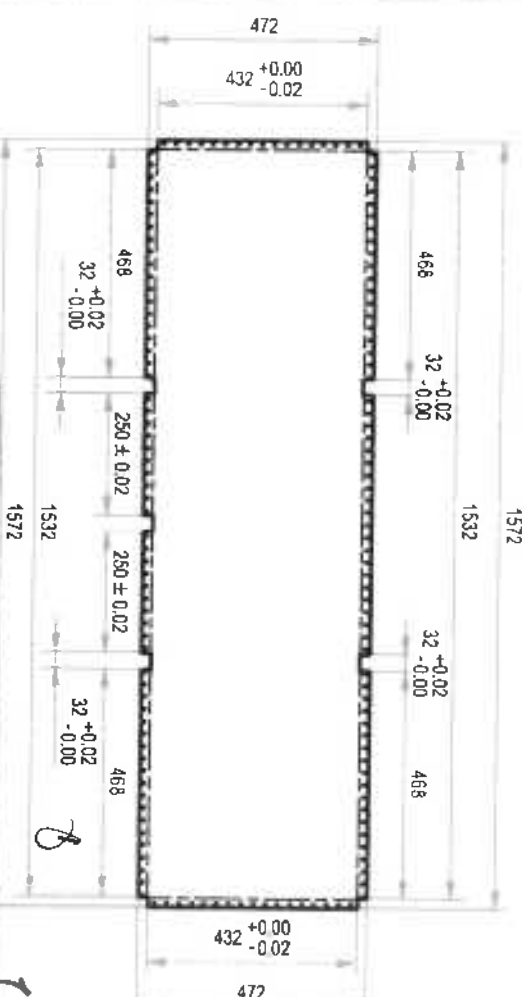

QUANTITY: 2

FLAT PATTERN: GALVANIZED SHEET GAUGE #18, PAINTED

Use 3/16" blind rivet spaced @ 1" O.C.



TECHNICAL
EDUCATION AND
SKILLS
DEVELOPMENT
AUTHORITY

PROJECT TITLE:
**MOBILE TRAINING
LABORATORY**

CREATED BY: J.A.

Scale: 1:15

Sheet No.: 1/

N

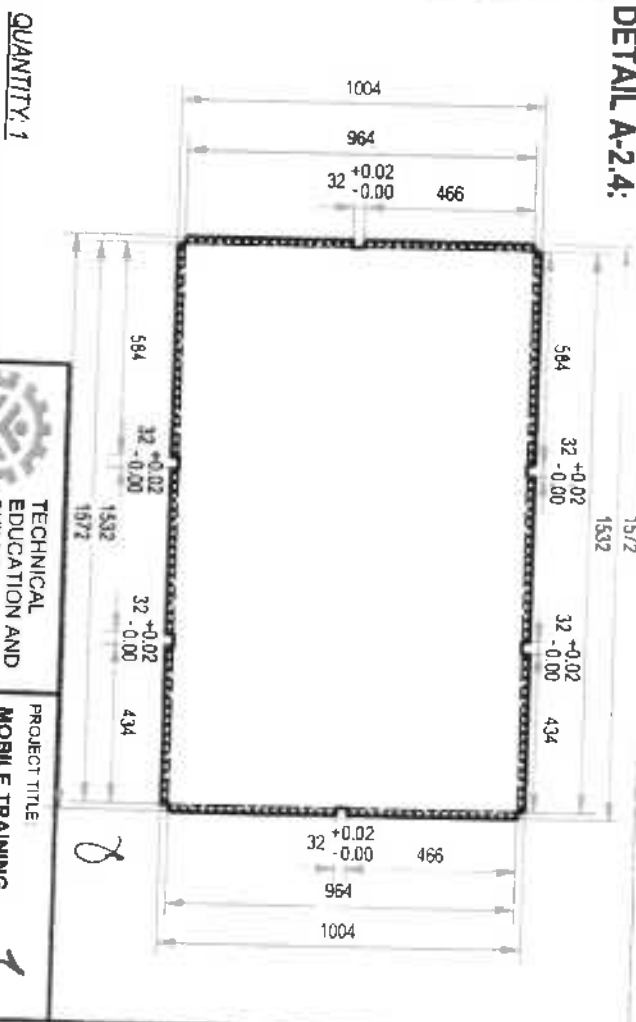
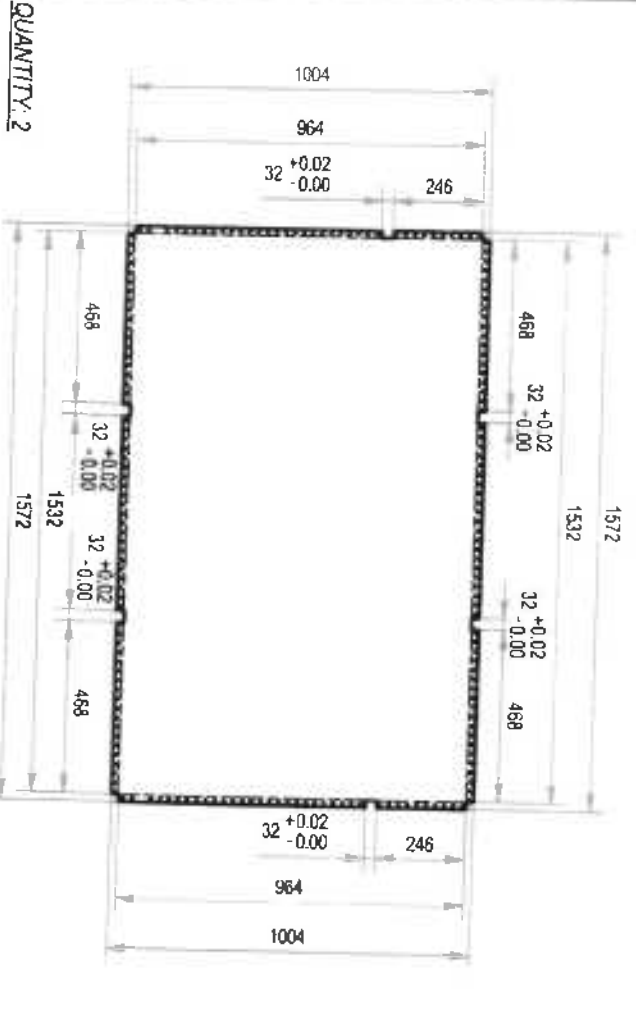
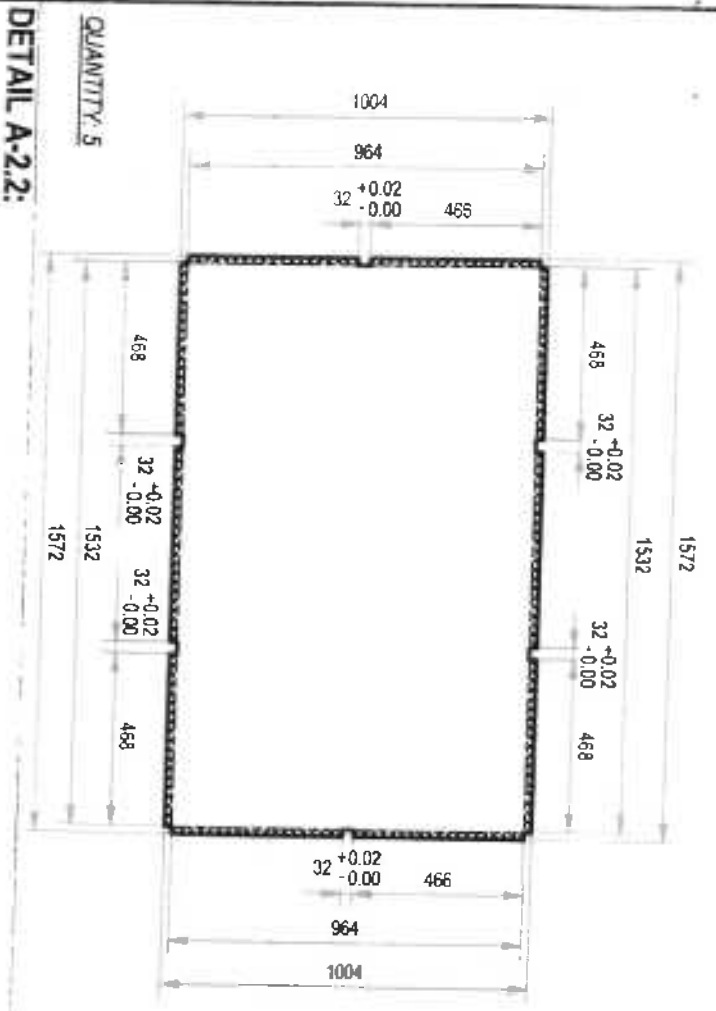

FLAT PATTERN: GALVANIZED SHEET GAUGE #18 PAINTED

Use 3/8" blind rivet spaced @ 1" O.C.



TECHNICAL EDUCATION AND SKILLS DEVELOPMENT AUTHORITY

PROJECT TITLE
MOBILE TRAINING LABORATORY

1

Created by: JA

Scale: 1:20

Drawn by: 1/

PRODUCED BY AN AUTODESK EDUCATIONAL PRODUCT

DETAIL A-3.1:

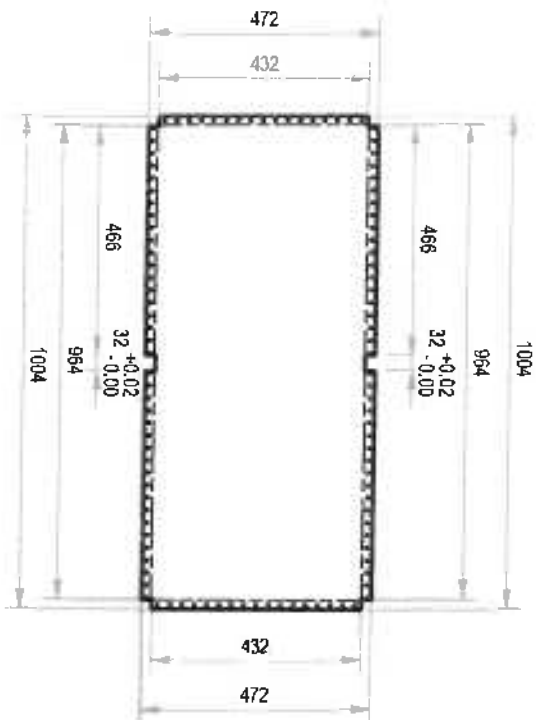

QUANTITY: 5

DETAIL A-3.3:

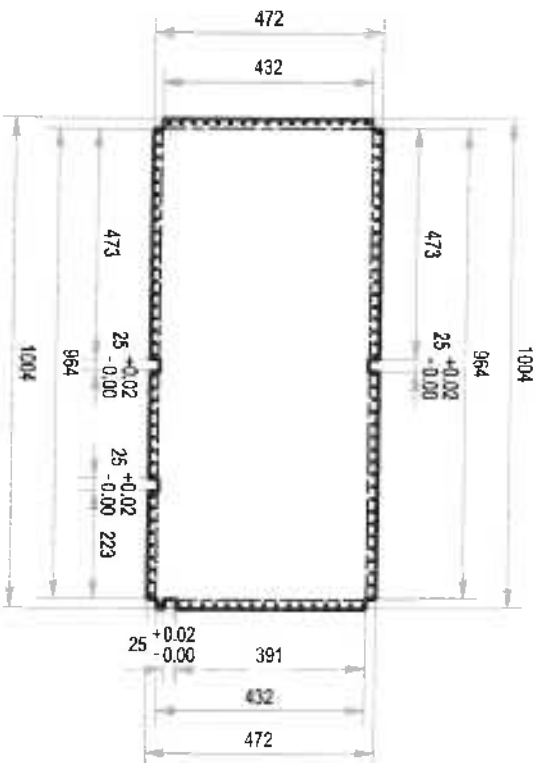

QUANTITY: 1

DETAIL A-3.4:

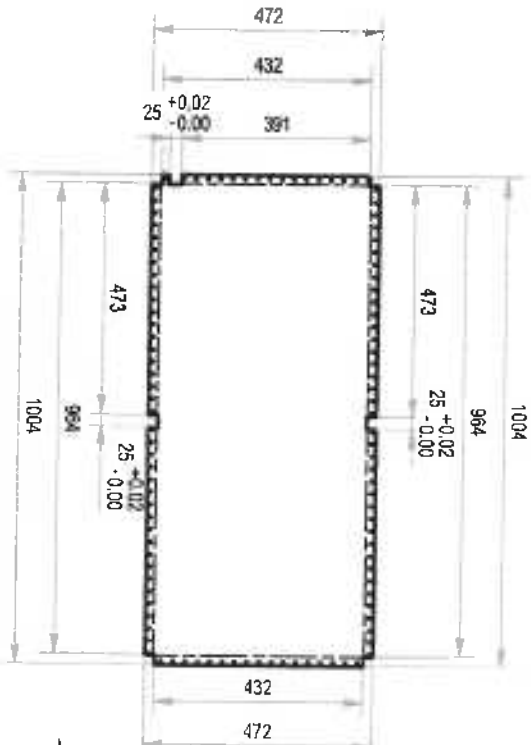

QUANTITY: 2

DETAIL A-3.2:

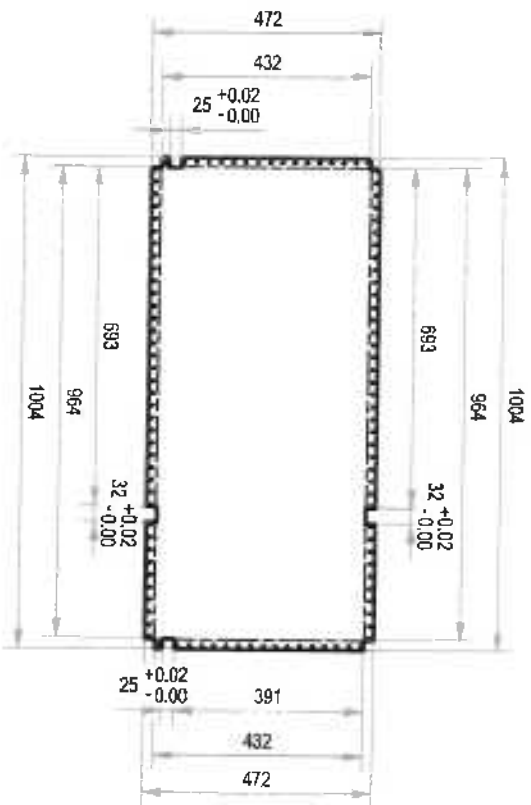

QUANTITY: 4

FLAT PATTERN: GALVANIZED SHEET GAUGE #18, PAINTED

Use 3/16" blind rivet spaced @ 1" O.C.



TECHNICAL EDUCATION AND SKILLS DEVELOPMENT AUTHORITY

PROJECT TITLE: MOBILE TRAINING LABORATORY

DRAWN BY: JBA

Scale: 1:15

Sheet No.: 1/1

DETAIL A-4.1:

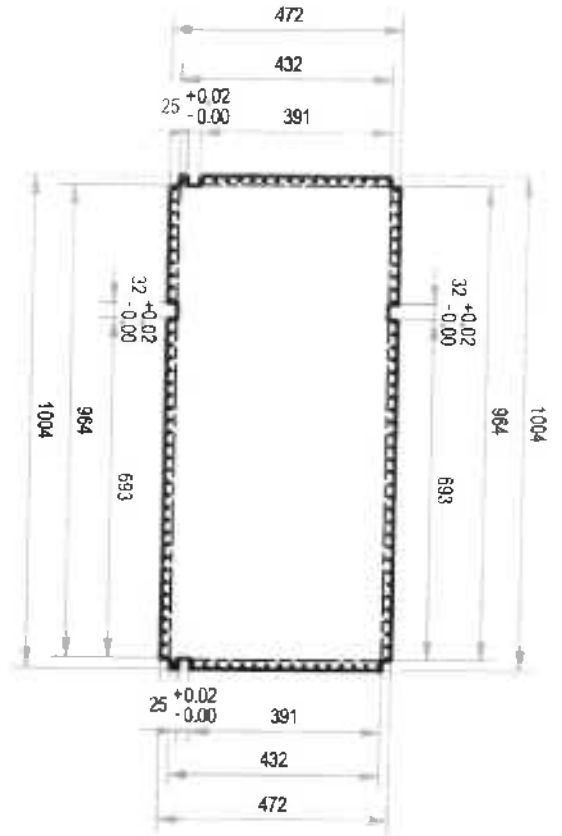

QUANTITY: 4

DETAIL A-4.2:

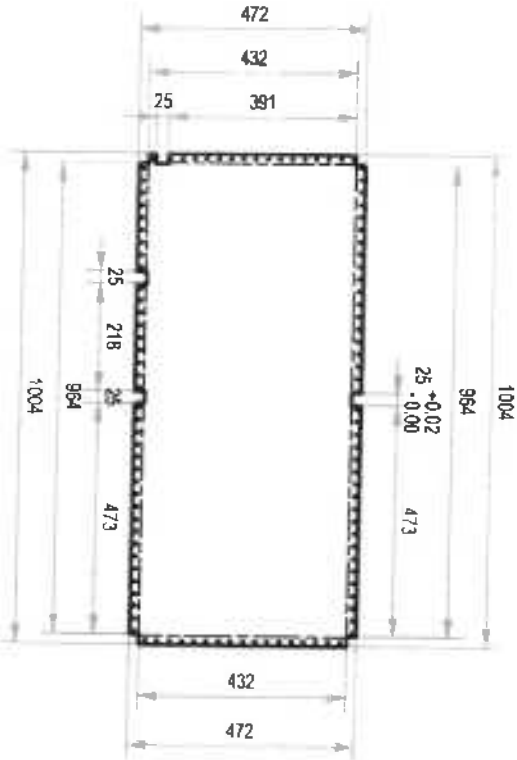

QUANTITY: 2

DETAIL A-4.3:

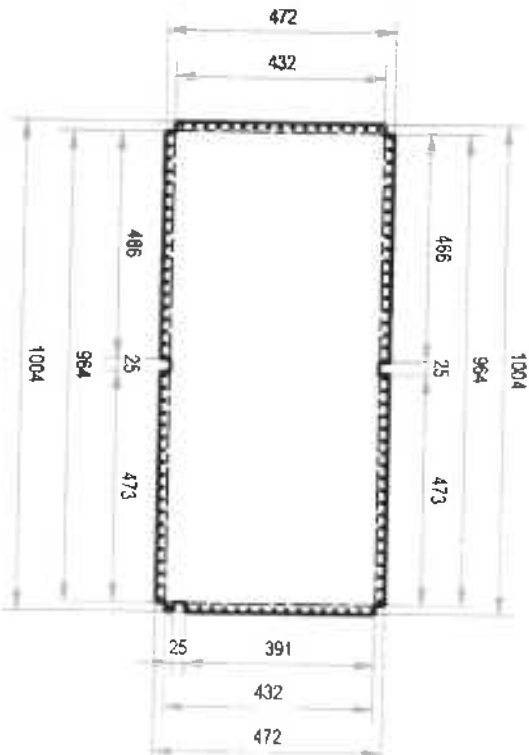

QUANTITY: 2

FLAT PATTERN: GALVANIZED SHEET GAUGE #18, PAINTED

Handwritten mark resembling the letter 'B'.

Use 3/16" blind rivet spaced @ 1" O.C.



TECHNICAL
EDUCATION AND
SKILLS
DEVELOPMENT
AUTHORITY

PROJECT TITLE
MOBILE TRAINING
LABORATORY



DRAWN BY: JKA

SCALE: 1:15

SHEET NO: 1/1

DETAIL A-5.1.

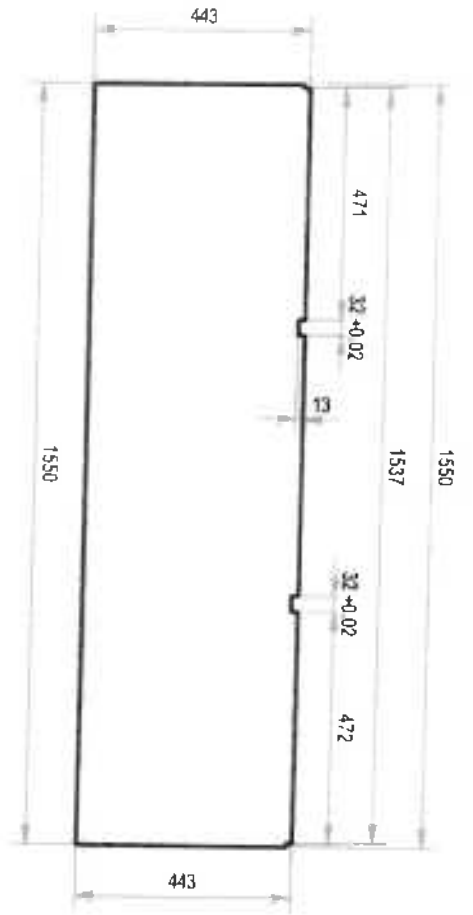

DETAIL A-5.3.

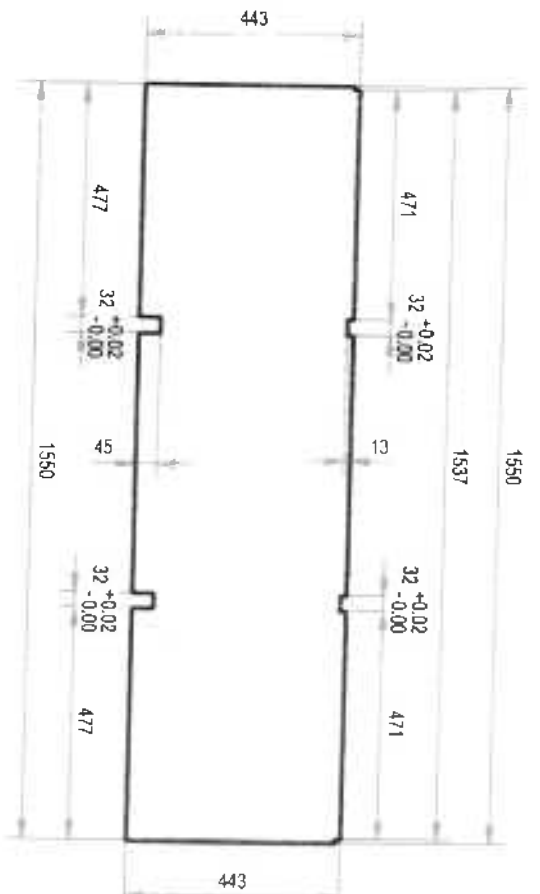

QUANTITY: 1

QUANTITY: 2

DETAIL A-5.2:

DETAIL A-5.4:

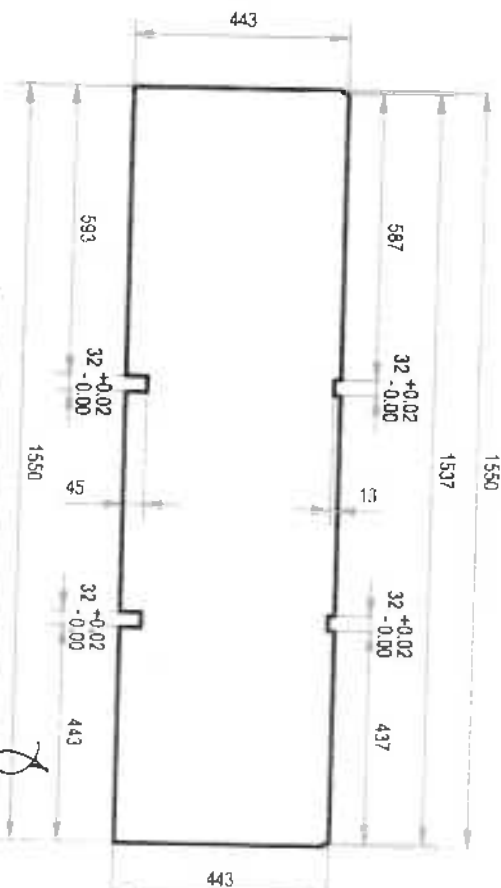
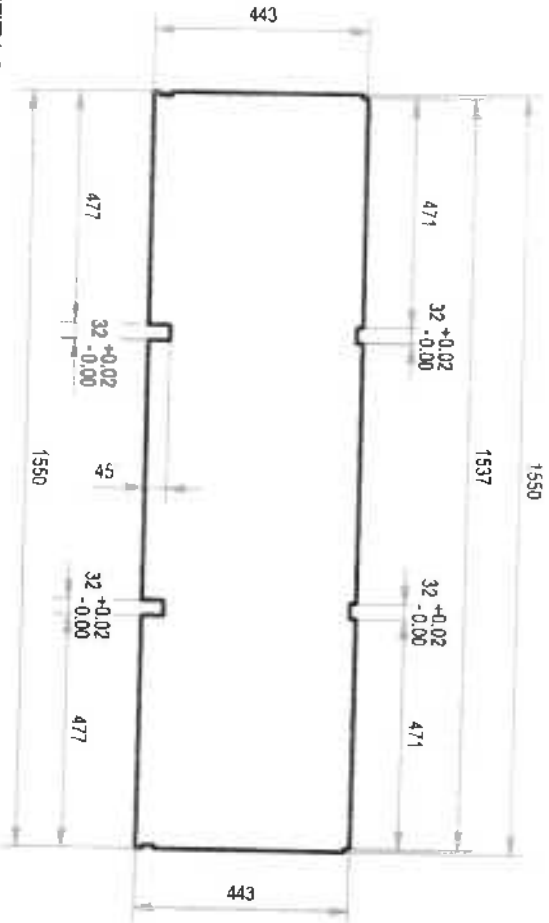

QUANTITY: 6

QUANTITY: 1

GALVANIZED SHEET GAUGE #18, PAINTED

PRODUCED BY AN AUTODESK EDUCATIONAL PRODUCT



TECHNICAL
EDUCATION AND
SKILLS
DEVELOPMENT
AUTHORITY

PROJECT TITLE
MOBILE TRAINING
LABORATORY

DATE: 07/10/15

Scale: 1:15

1/1

Handwritten signature

DETAIL B-1.1:

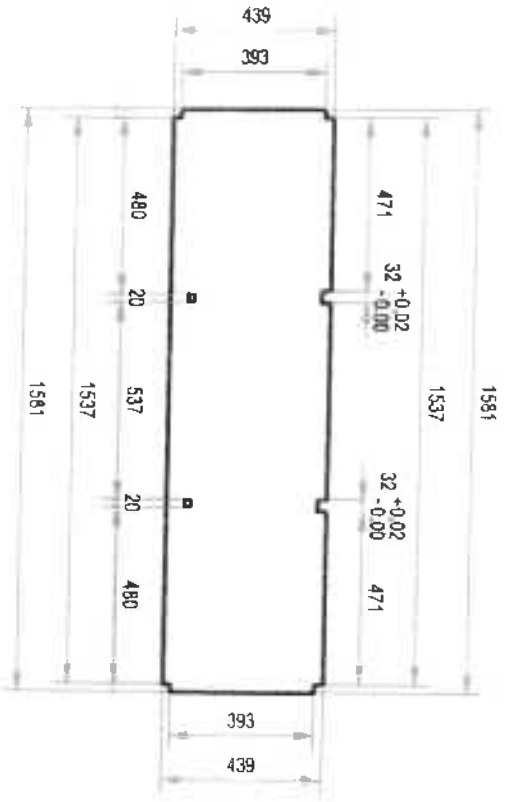

QUANTITY: 2

DETAIL B-1.2:

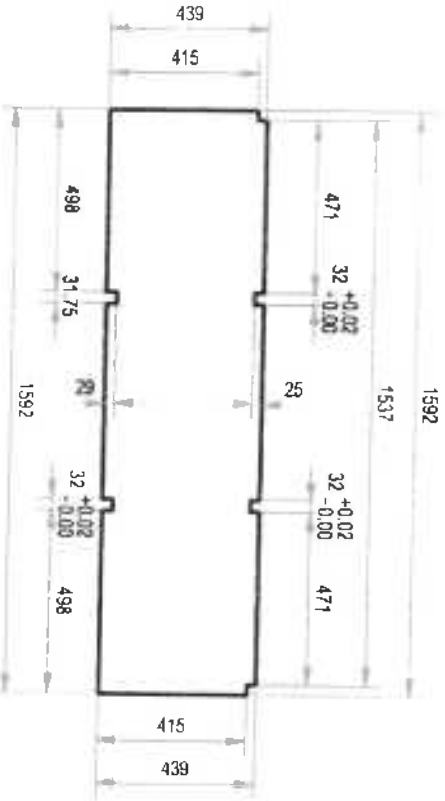

QUANTITY: 1

GALVANIZED SHEET GAUGE #18, PAINTED

DETAIL B-1.3:

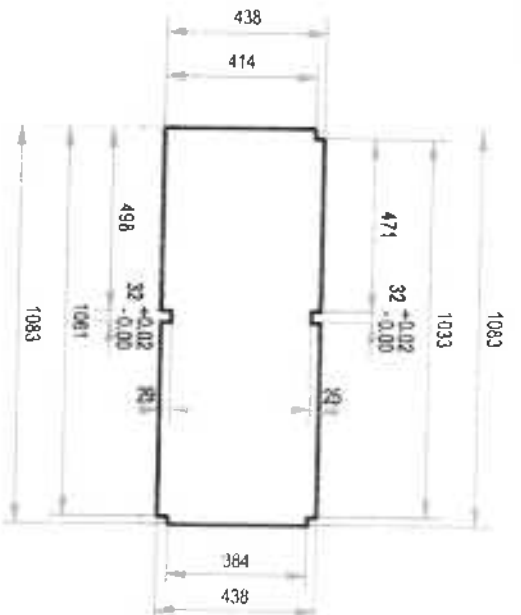

QUANTITY: 1

DETAIL B-1.4:

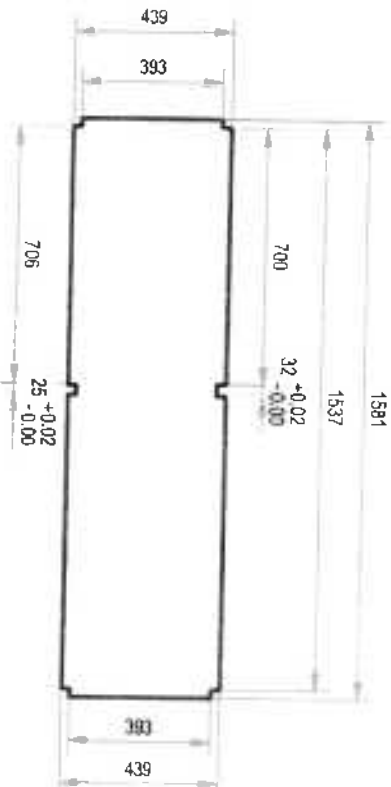

QUANTITY: 2

PRODUCED BY AN AUTODESK EDUCATIONAL PRODUCT



TECHNICAL EDUCATION AND SKILLS DEVELOPMENT AUTHORITY

PROJECT TITLE
MOBILE TRAINING LABORATORY

DRAWN BY: J/A

SCALE: 1:20

HEET NO.
1 /

DETAIL C-1.1:

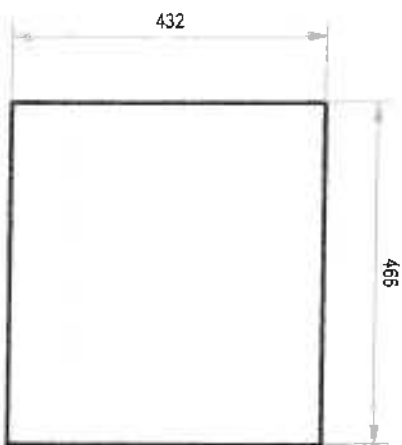

QUANTITY: 15

DETAIL C-1.3:

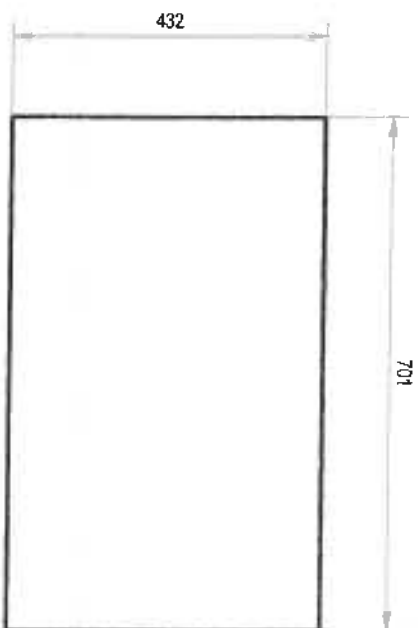

QUANTITY: 2

DETAIL C-1.2:

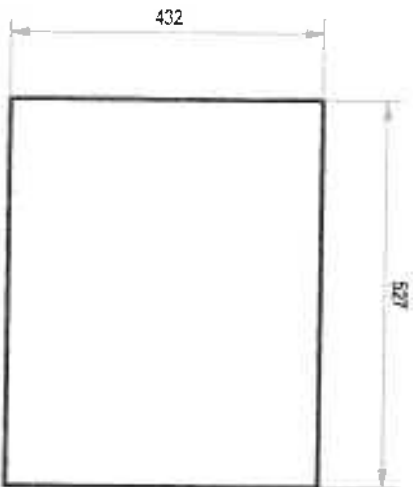

QUANTITY: 9

DETAIL D-1.1:

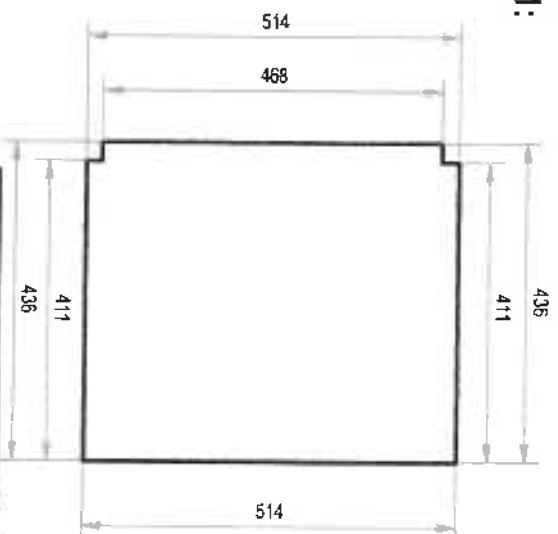

QUANTITY: 1

GALVANIZED SHEET GAUGE #18, PAINTED



TECHNICAL EDUCATION AND SKILLS DEVELOPMENT AUTHORITY

PROJECT TITLE
MOBILE TRAINING LABORATORY

DRAWN BY JSA

SCALE: 1:10

SHEET NO. 1/1

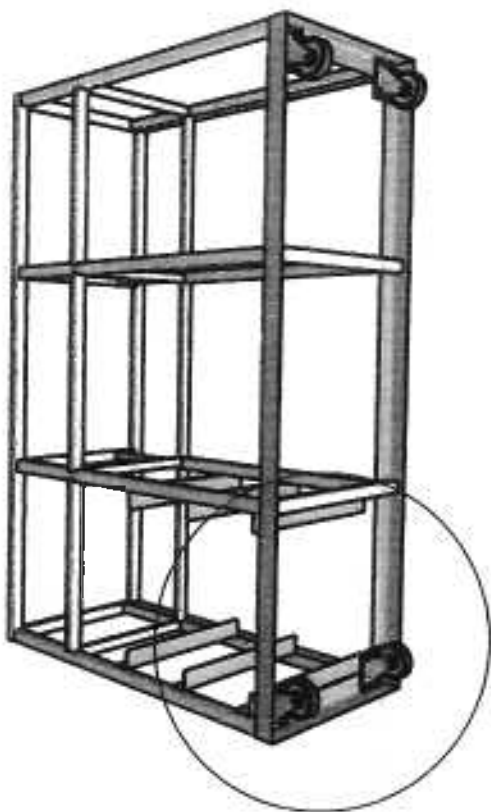

A

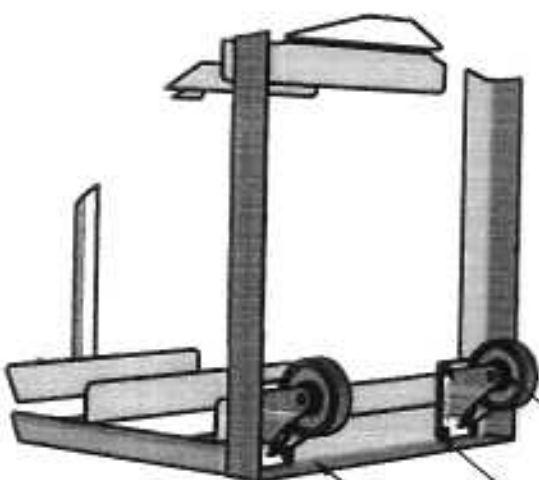

A (1 : 10)

4 pcs. of 4" polyurethane roller wheels
with top plate bearing and self-locking;
load capacity: 125 lbs. per wheel

Welded in 4" x 4" x 5 mm metal plate

2" x 2" x 3/16" bar, painted



TECHNICAL
EDUCATION AND
SKILLS
DEVELOPMENT
AUTHORITY

PROJECT TITLE:
**MOBILE TRAINING
LABORATORY**

DESIGN BY: JSA

Scale: 1:20

Sheet No. 1 /

2

N

DETAIL F: RUBBER DOOR SEAL

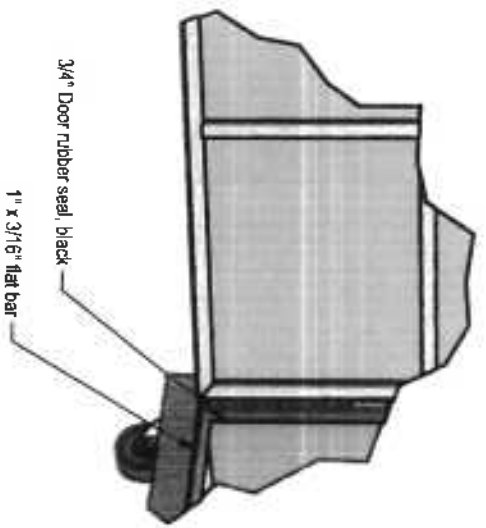
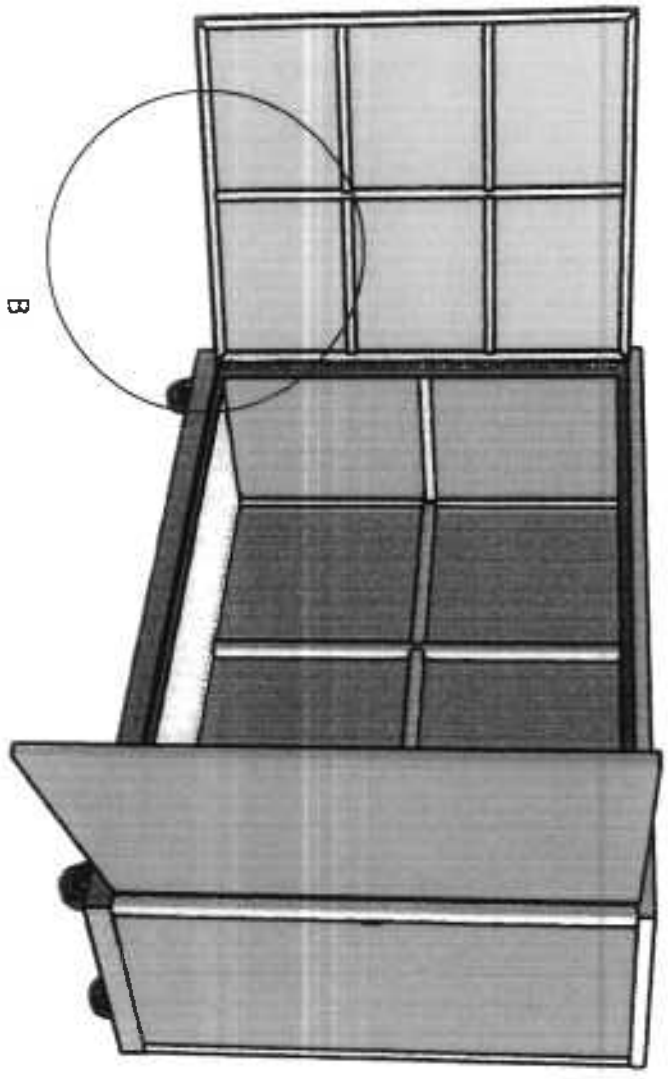

B (1:10)

REPRODUCED BY THE UNIVERSITY OF PHOENIX AUTHORITY

| | | |
|---|---|--------------------|
|  <p>TECHNICAL EDUCATION AND SKILLS DEVELOPMENT AUTHORITY</p> | <p>PROJECT TITLE</p> <p>MOBILE TRAINING LABORATORY</p> | |
| | <p>Drawn by: PJA</p> | <p>Scale: 1/25</p> |

2

N

Handwritten signature

| MTL BOX COVER FRAME, SIDEWAY SWING | | | |
|------------------------------------|------------------------------|-------------|-----|
| NO. | MATERIAL | LENGTH, mm | Qty |
| 1 | Gauge #18 G.I. sheet | 1,009 x 836 | 2 |
| 2 | 1" x 1" x 1.5 mm square tube | 968,25 | 4 |
| 3 | 1" x 1" x 1.5 mm square tube | 928,25 | 2 |
| 4 | 1" x 1" x 1.5 mm square tube | 793,65 | 4 |
| 5 | 1" x 1" x 1.5 mm square tube | 369,825 | 8 |
| 6 | 2" x 2mm piano hinge | 968 | 2 |
| TOTAL | | | 22 |

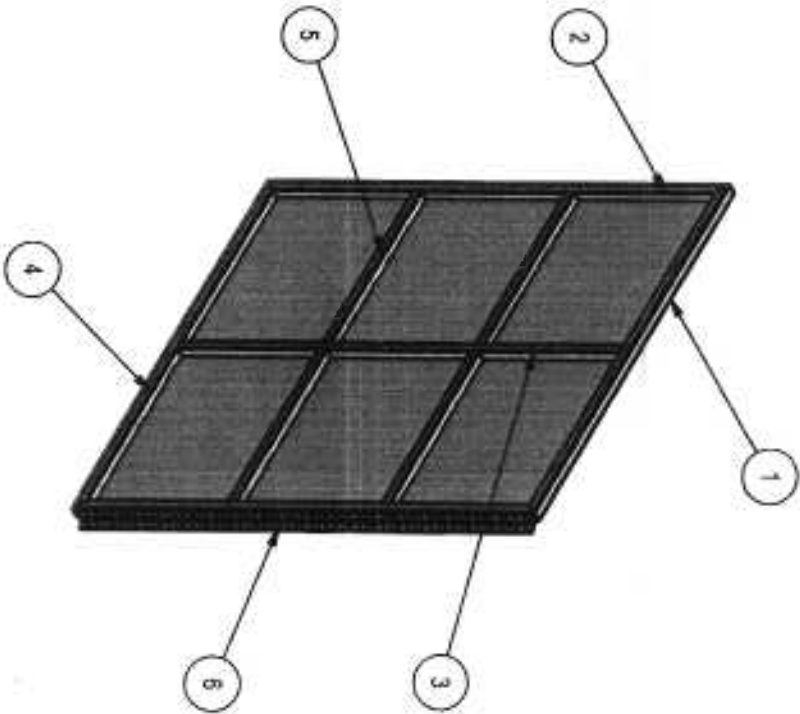

MTL DOOR FRAME



PROJECT TITLE
MOBILE TRAINING LABORATORY

DRAWN BY: JPA
 Scale: 1:15
 SHEET NO. 1/

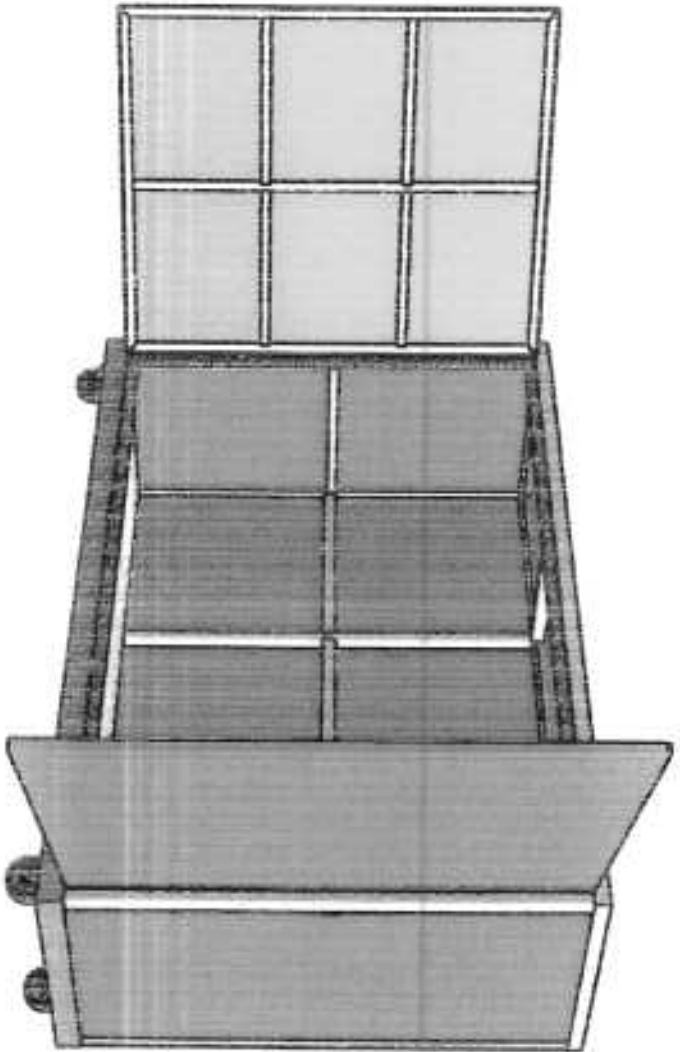

Include 2-sides metal handle
and lock with padlock for the
door (not shown in the drawing)

8 7



TECHNICAL
EDUCATION AND
SKILLS
DEVELOPMENT
AUTHORITY

PROJECT TITLE
**MOBILE TRAINING
LABORATORY**

DATE: 08/04/2014

SLIDE 115

17

M

of

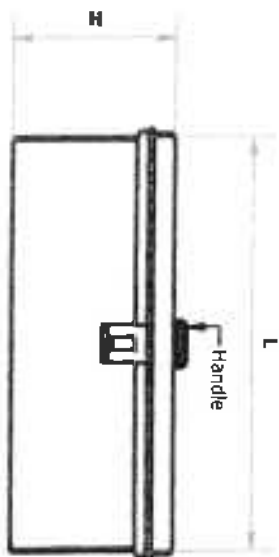

FRONT VIEW

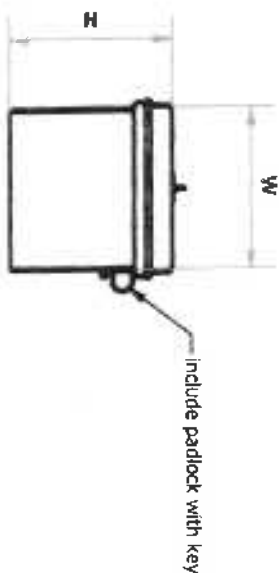

SIDE VIEW

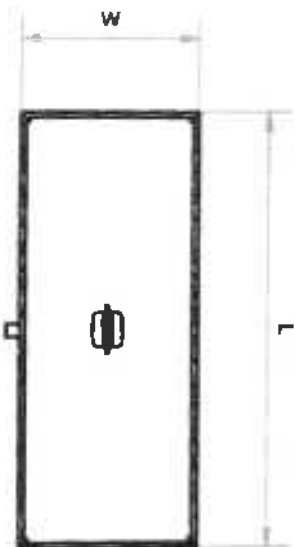

TOP VIEW

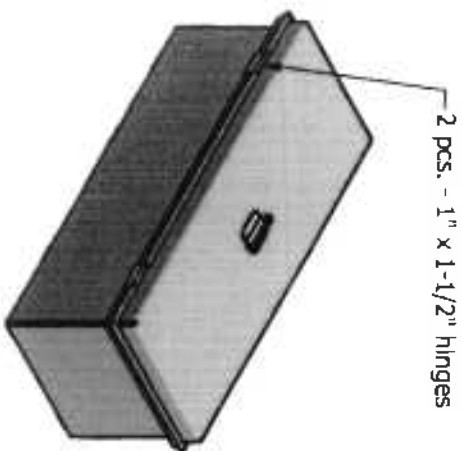

ISOMETRIC VIEW

| TOOLBOX | | | |
|---------|--------------------|--|---------------------|
| NO. | DIMENSION (L x | MATERIAL | NO. OF PCS. PER SET |
| 1 | 18" x 7" x 7" | Small Engine Repair - G.A. #18 galvanized sheet, painted | 12 |
| 3 | 18" x 7" x 8" | Appliance Repair -G.A. #18 galvanized sheet, painted | 6 |
| | 18" x 7" x 8" | Electrical Installation and Maintenance - G.A. #18 galvanized sheet, painted | 6 |
| 4 | 20" x 7" x 8" | Small Engine Repair - G.A. #18 galvanized sheet, painted | 6 |
| 5 | 16" x 20" x 4-1/2" | Cookery - Plastic, white | 3 |
| 6 | 16" x 20" x 4-1/2" | Food Processing - Plastic, white | 3 |



TECHNICAL EDUCATION AND SKILLS DEVELOPMENT AUTHORITY

PROJECT TITLE: **COMPACT MOBILE UNIT**

DATE: 1/24/18

SCALE: 1/8"

SHEET NO: 1/1

COMPARATIVE TECHNICAL SPECIFICATION

| TESDA'S SPECIFICATIONS | | BIDDER'S SPECIFICATIONS | | |
|------------------------|---------------------------------|--------------------------------------|------------------|----------------|
| No. | Item | Specifications | Item/Brand/Model | Specifications |
| Lot 7 | Plumbing NC II MTL Box No. 8 | Please refer to the attached drawing | | |

Name of Bidder: _____

Name and Signature of Authorized Representative: _____
 Position/Designation: _____
 Date: _____

P John
at 1 pm

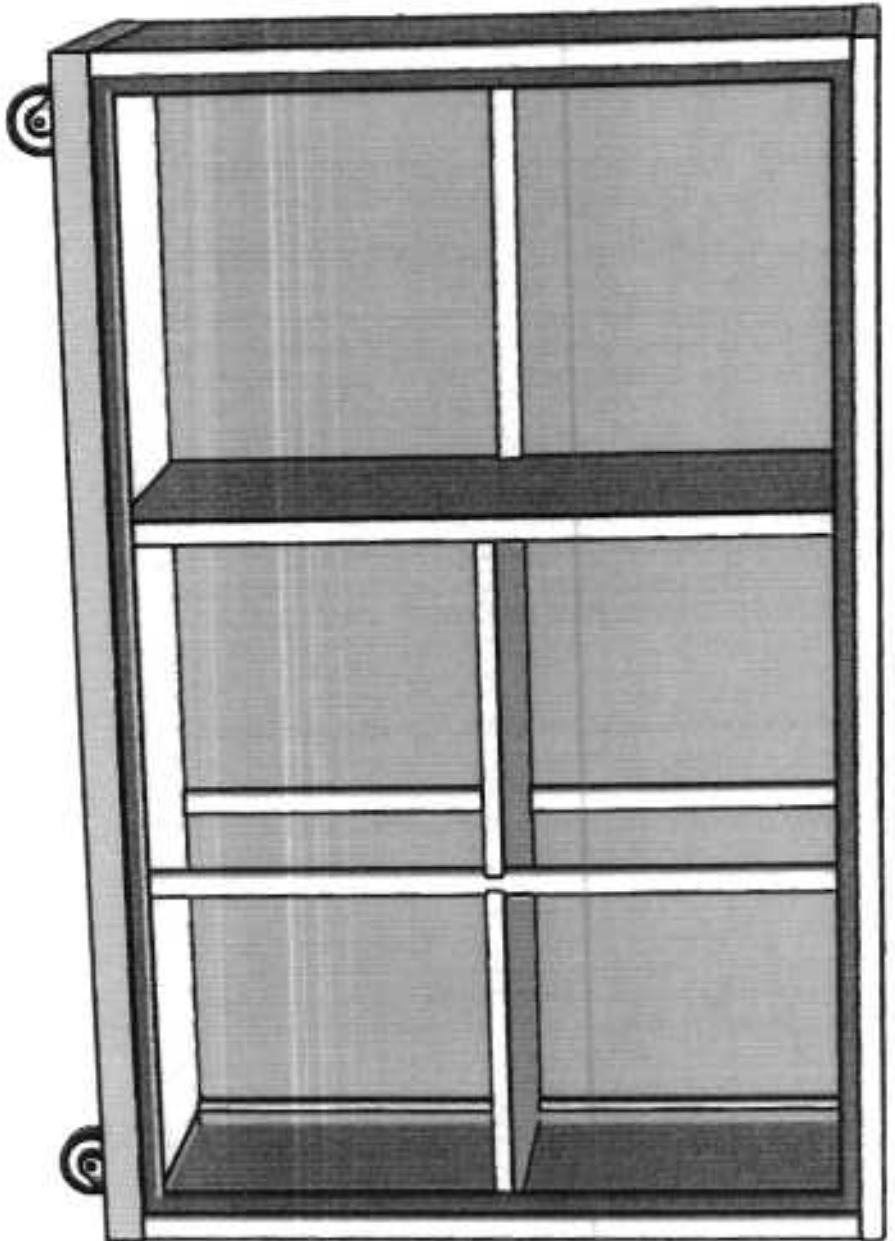

MTL BOX NO. 8
 (PLUMBING)
 QUANTITY:
 (The door is not shown in the
 drawing)

2



TECHNICAL
 EDUCATION AND
 SKILLS
 DEVELOPMENT
 AUTHORITY

PROJECT TITLE
 MOBILE TRAINING
 LABORATORY

N

DRAWING NO. / PK. Scale: 1:10

Sheet No. 1 /

| MTL BOX 8 FRAME | | | |
|-----------------|------------------------------------|------------|-----|
| NO. | MATERIAL | LENGTH, mm | QTY |
| 1 | 2" x 2" x 3/16" angle bar | 1,600.00 | 2 |
| 2 | 2" x 2" x 3/16" angle bar | 500.00 | 2 |
| 3 | 1 1/4" x 1 1/4" x 2 mm square tube | 493.65 | 2 |
| 4 | 1 1/4" x 1 1/4" x 2 mm square tube | 968.25 | 6 |
| 5 | 1 1/4" x 1 1/4" x 2 mm square tube | 1,600.00 | 2 |
| 6 | 1 1/4" x 1 1/4" x 2 mm square tube | 500.00 | 2 |
| 7 | 1 1/4" x 1 1/4" x 2 mm square tube | 436.50 | 2 |
| 8 | 1 1/4" x 1 1/4" x 2 mm square tube | 1,473.00 | 1 |
| 9 | 1 1/4" x 1 1/4" x 2 mm square tube | 967.04 | 2 |
| 10 | 1" x 1" x 1.5 mm square tube | 436.5 | 2 |
| 11 | 1" x 1" x 1.5 mm square tube | 385.29 | 2 |
| 13 | 1" x 1" x 1.5 mm square tube | 892.04 | 1 |
| TOTAL | | | 26 |

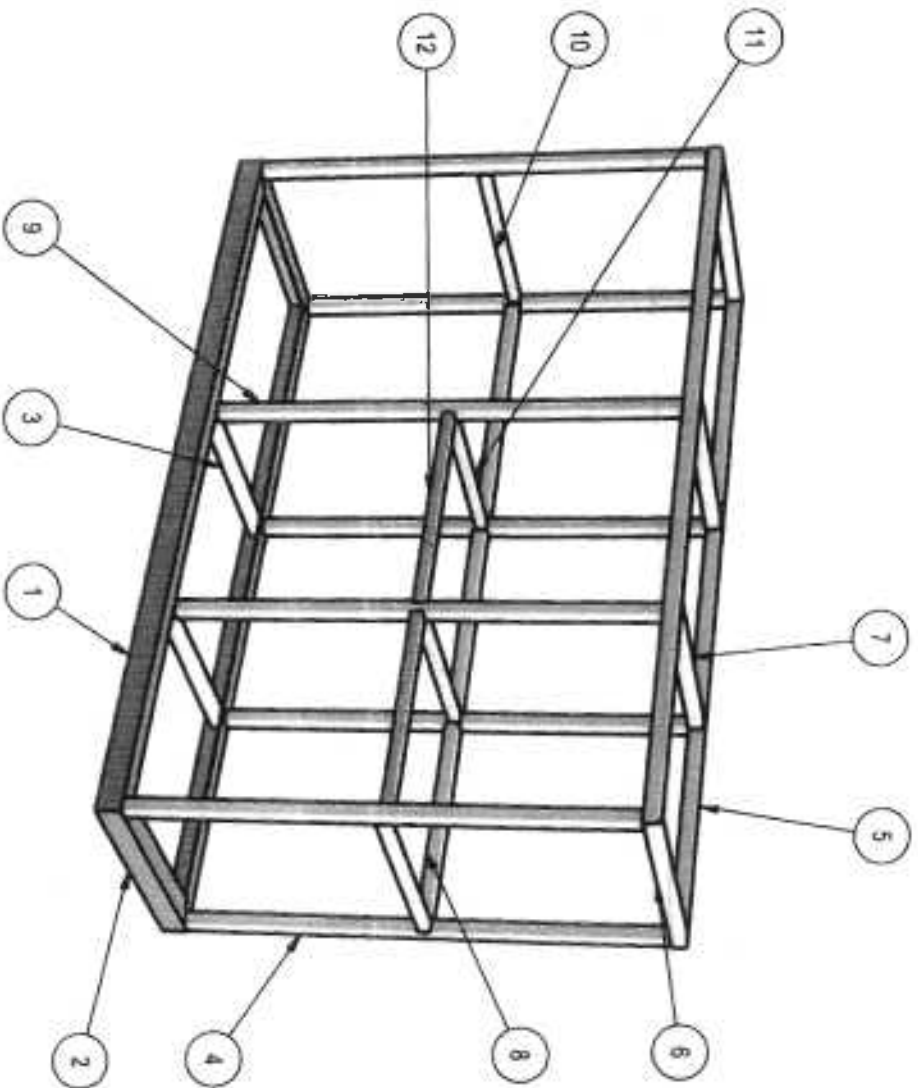

MTL BOX NO. 8 FRAME
(PLUMBING)
 (The door is not shown in the drawing)

TECHNICAL
 EDUCATION AND
 SKILLS
 DEVELOPMENT
 AUTHORITY

PROJECT TITLE
**MOBILE TRAINING
 LABORATORY**

DESIGN BY: JVA
 SCALE: 1:15
 SHEET NO: 1/1

**MTL BOX NO. 8 FRAME
(PLUMBING)**
(The door is not shown in the drawing)

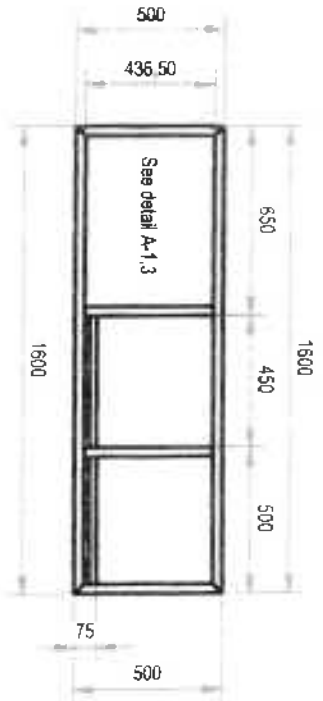

TOP VIEW

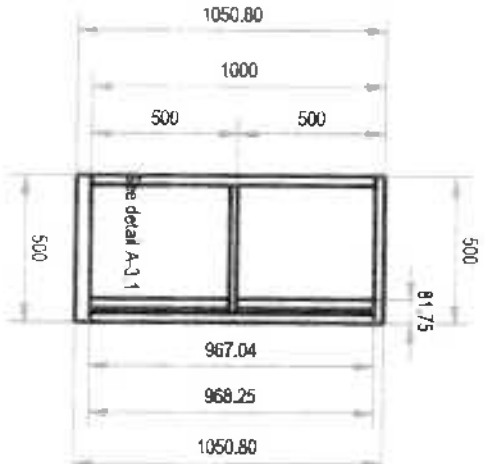

LEFT SIDE VIEW

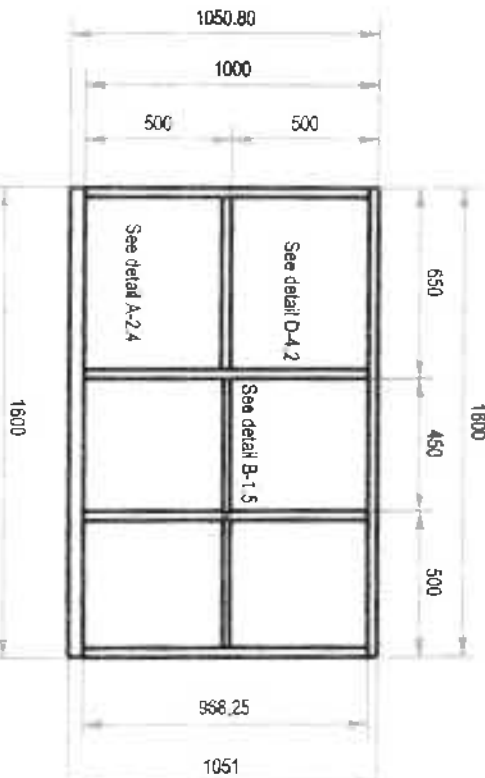

FRONT VIEW

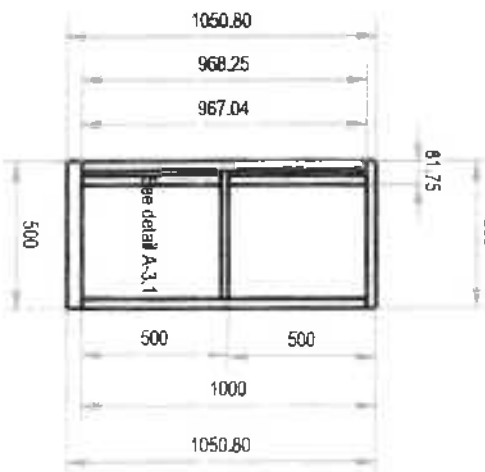

RIGHT SIDE VIEW

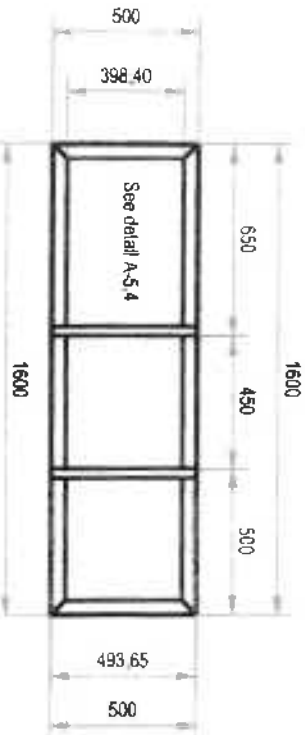

BOTTOM VIEW

- MTL BOX NO. 8**
- ⊕ All materials must be painted with anti-corrosive primer
 - Tube and bar are coated with light gray epoxy finish paint



TECHNICAL
EDUCATION AND
SKILLS
DEVELOPMENT
AUTHORITY

PROJECT TITLE:
**MOBILE TRAINING
LABORATORY**

7 N

Drawn by: JJA

Scale: 1:25

Drawn on:
1/

DETAIL A-1.1:

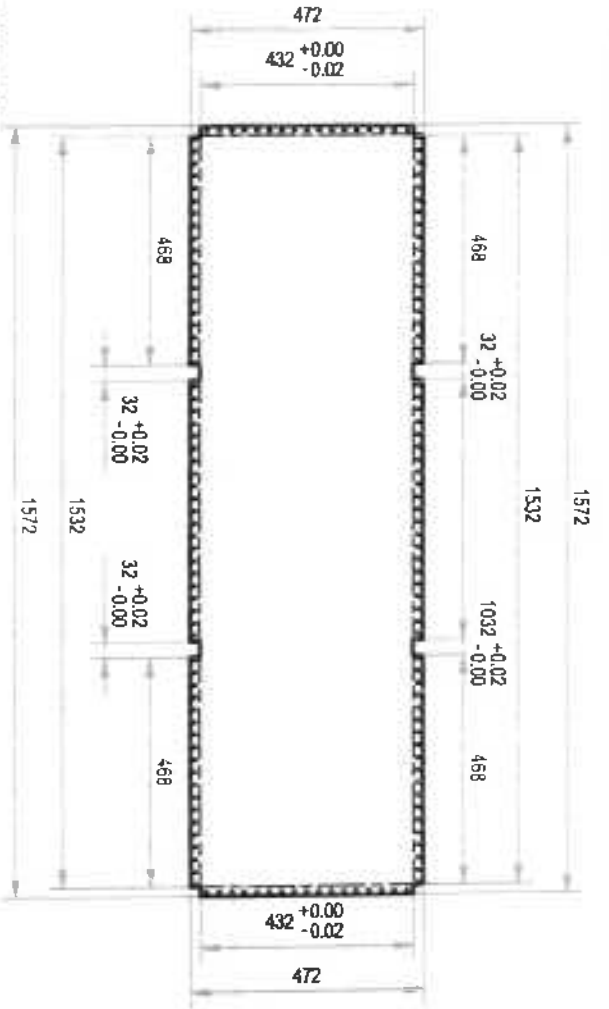

QUANTITY: 5

DETAIL A-1.3:

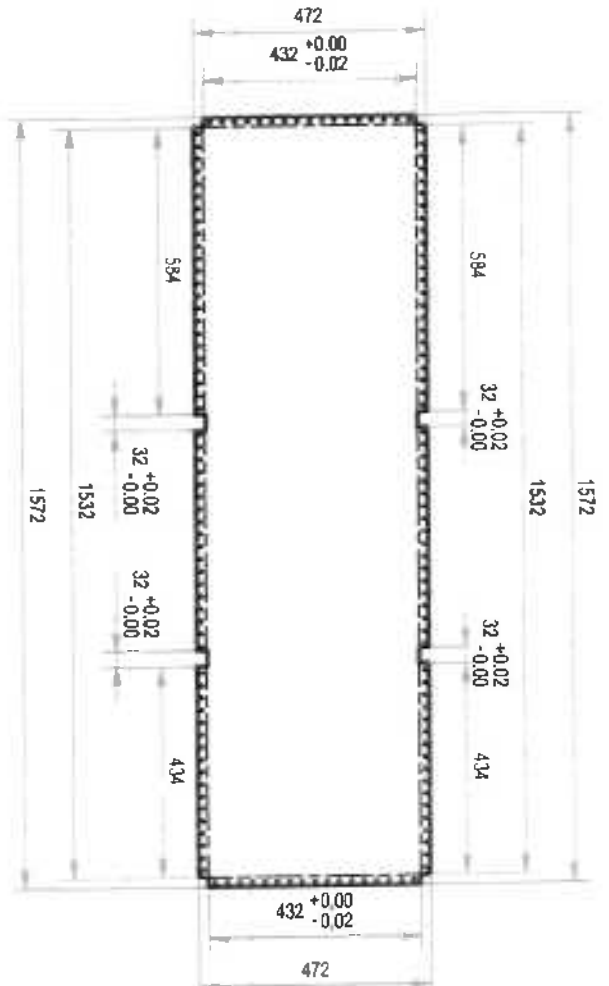

QUANTITY: 1

DETAIL A-1.2:

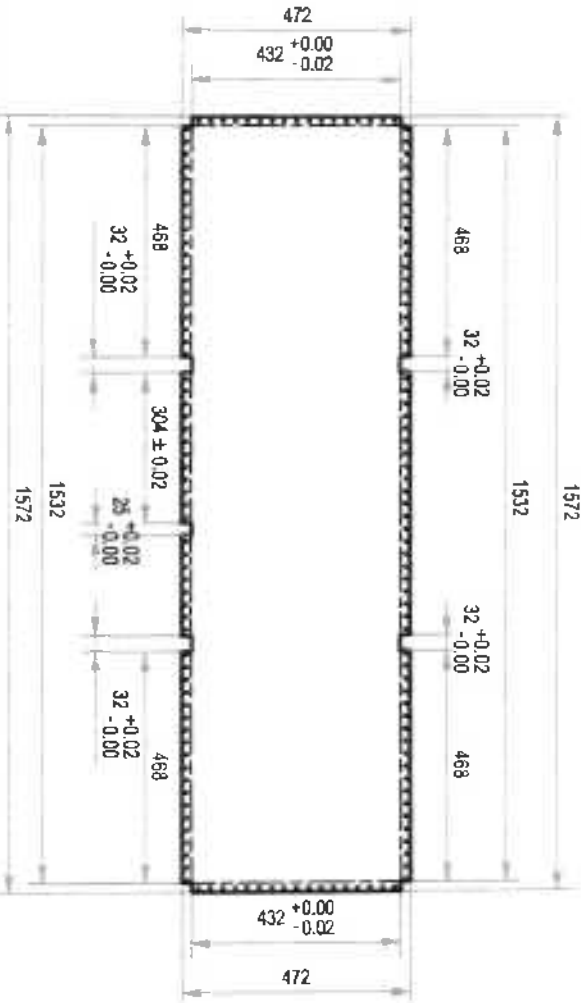

QUANTITY: 2

DETAIL A-1.4:

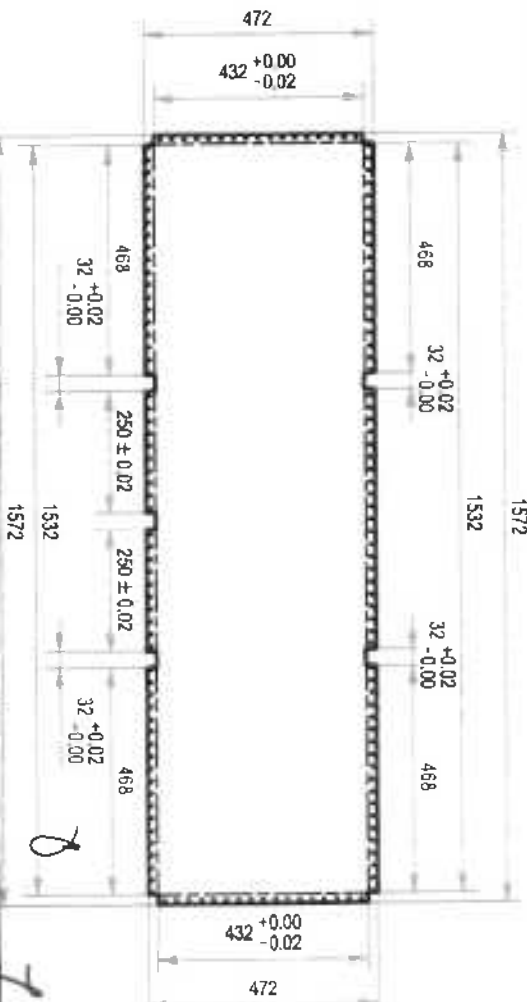

QUANTITY: 2

FLAT PATTERN: GALVANIZED SHEET GAUGE #18, PAINTED

Use 3/16" blind rivet spaced @ 1" O.C.



TECHNICAL EDUCATION AND SKILLS DEVELOPMENT AUTHORITY

PROJECT TITLE
MOBILE TRAINING LABORATORY

Drawn by: IAA

Scale: 1:15

Sheet No: 1/1

DETAIL A-2.1:

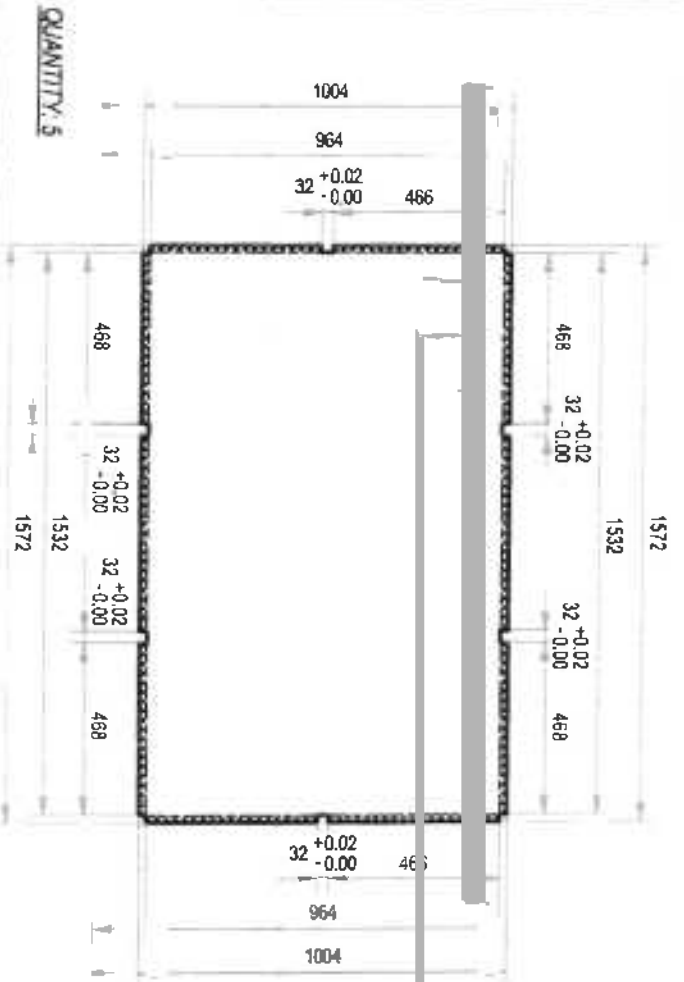

DETAIL A-2.3:

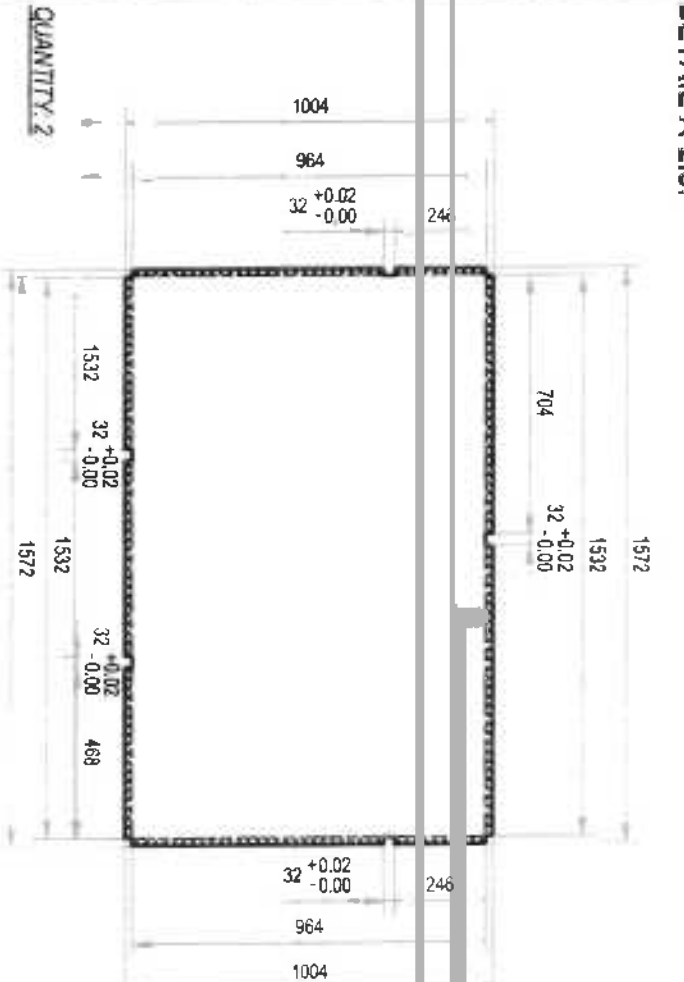

DETAIL A-2.2:

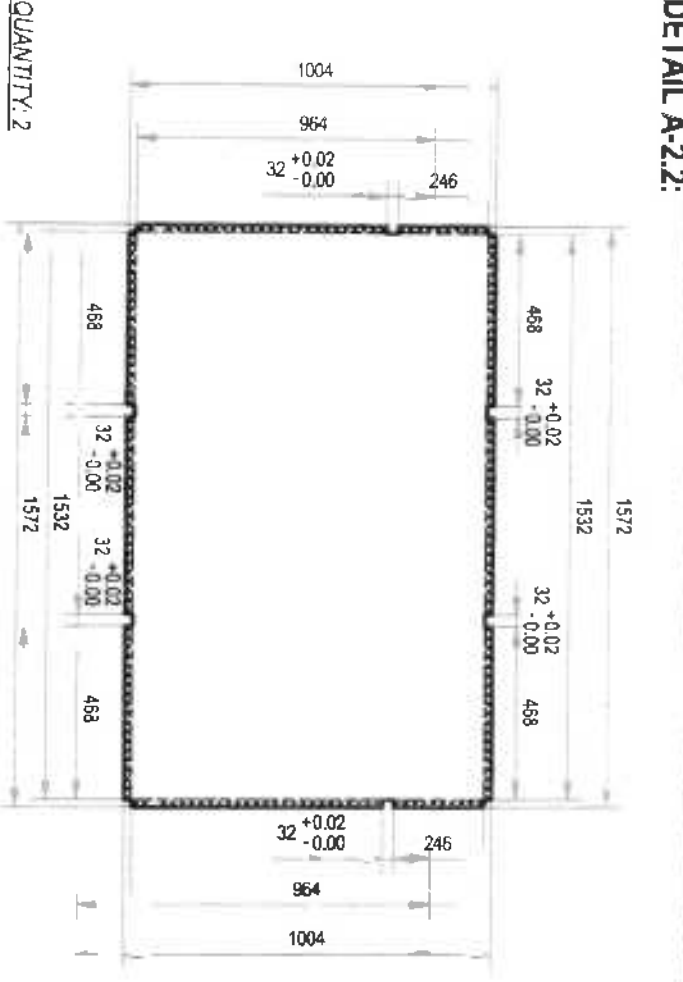

DETAIL A-2.4:

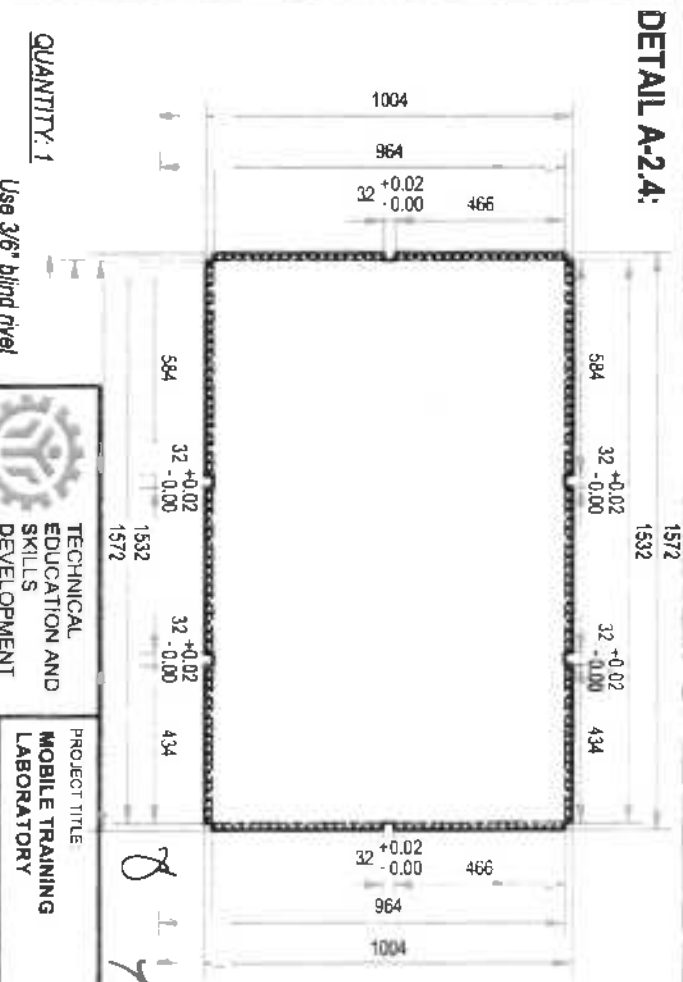

FLAT PATTERN- GALVANIZED SHEET GAUGE #18, PAINTED

PRODUCED BY AN AUTODESK EDUCATIONAL PRODUCT



TECHNICAL EDUCATION AND SKILLS DEVELOPMENT AUTHORITY

PROJECT TITLE
MOBILE TRAINING LABORATORY

DRAWN BY: JVA Scale 1:20

Sheet No. 11

QUANTITY: 5

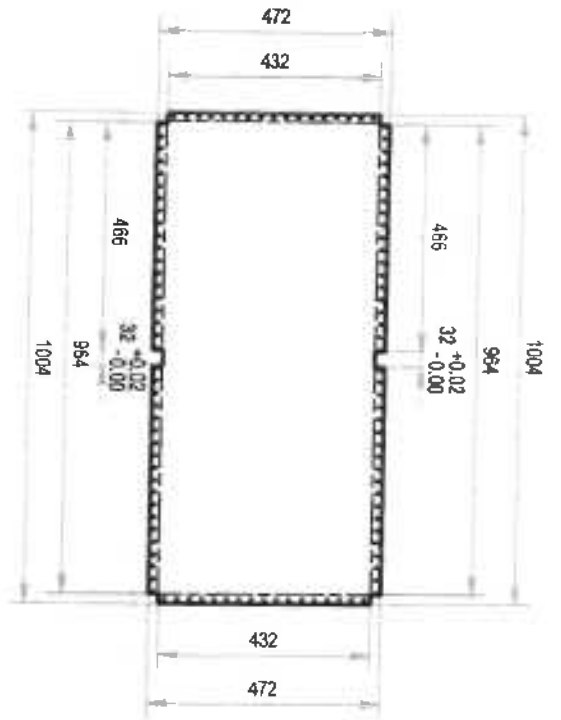

DETAIL A-3.2:

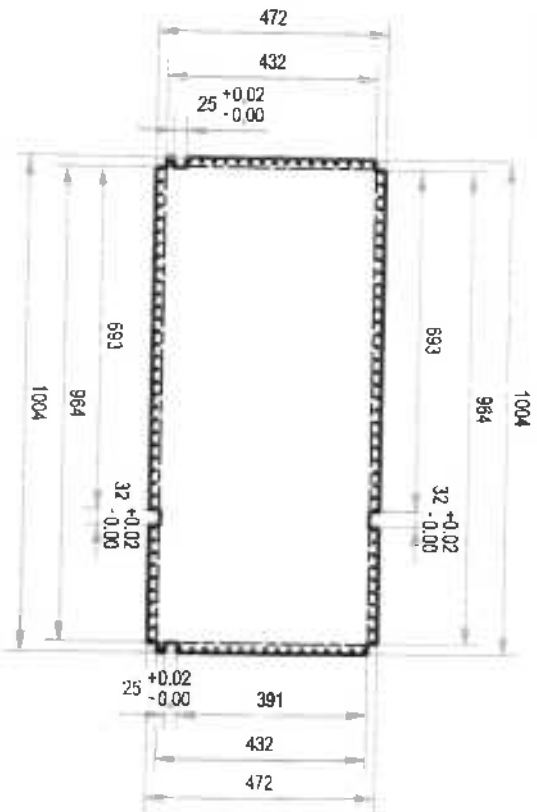

QUANTITY: 4

FLAT PATTERN: GALVANIZED SHEET GAUGE #18, PAINTED

DETAIL A-3.3:

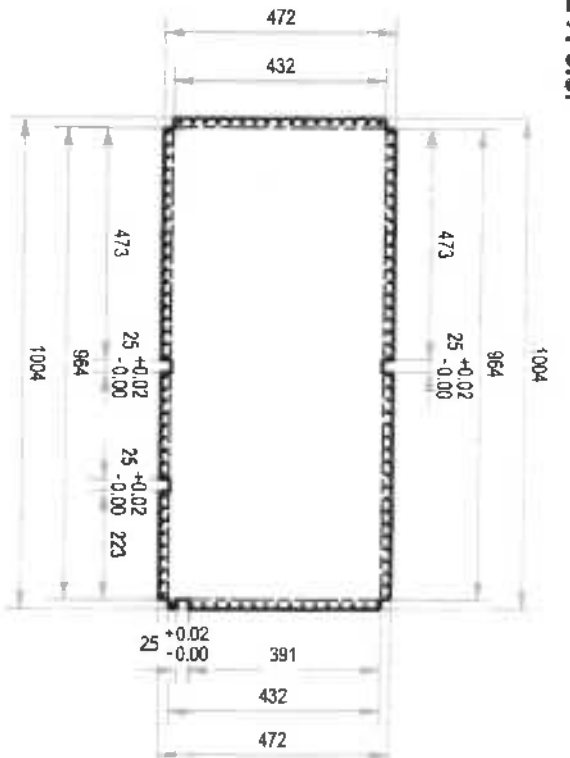

QUANTITY: 1

DETAIL A-3.4:

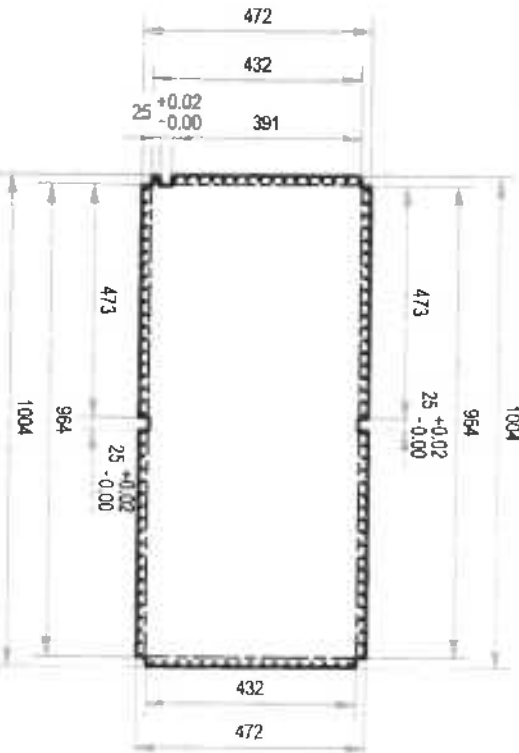

QUANTITY: 2

Use 3/16" blind rivet spaced @ 1" O.C.



TECHNICAL EDUCATION AND SKILLS DEVELOPMENT AUTHORITY

PROJECT TITLE
MOBILE TRAINING LABORATORY

Drawn by: JVA Scale: 1:15 Sheet No: 1/1

DETAIL A-5.1:

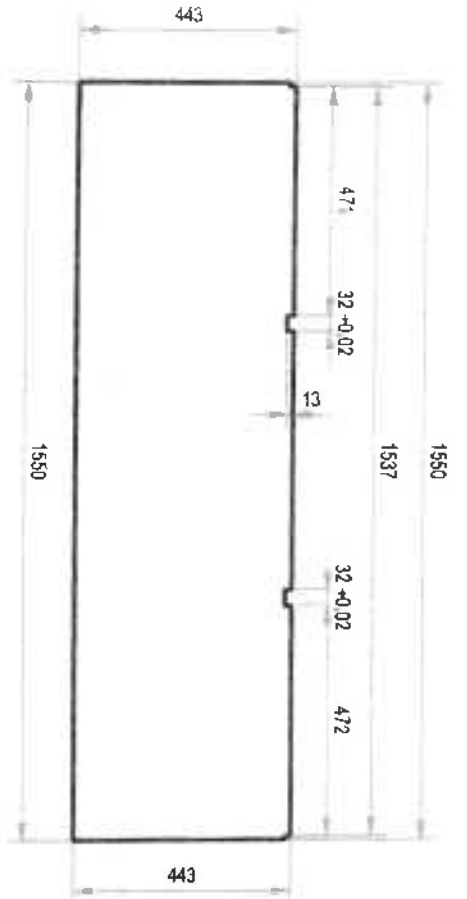

QUANTITY: 1

DETAIL A-5.3:

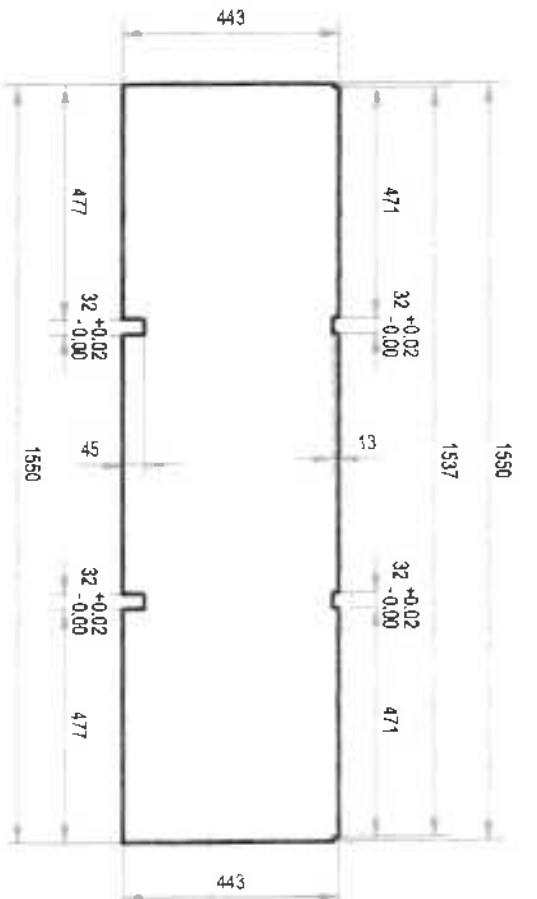

QUANTITY: 2

DETAIL A-5.2:

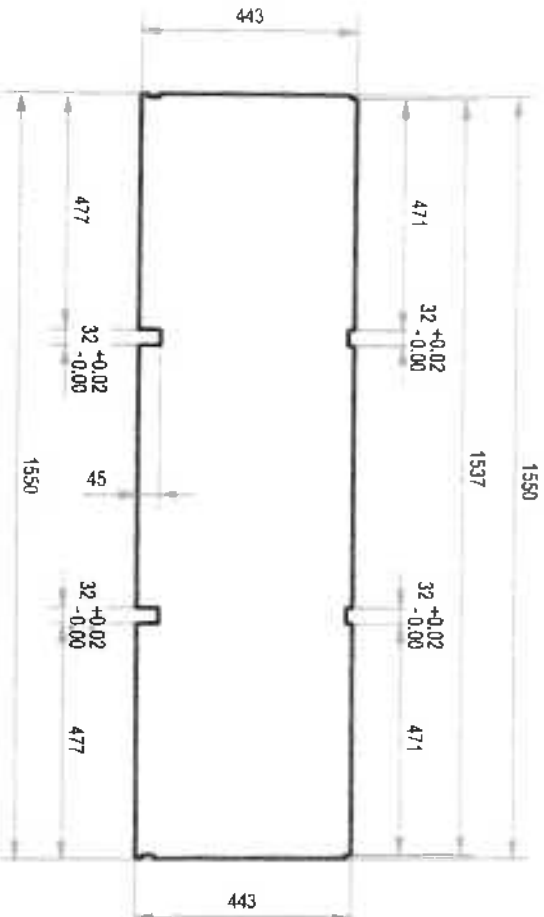

QUANTITY: 6

DETAIL A-5.4:

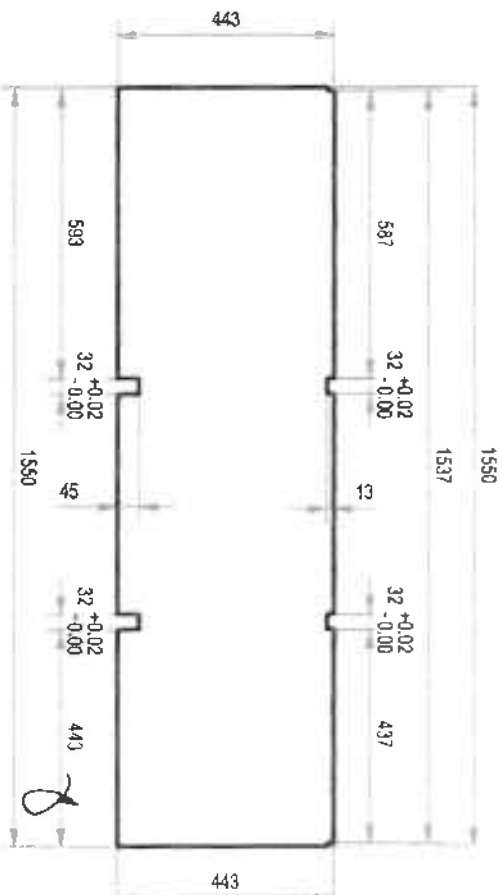

QUANTITY: 1

GALVANIZED SHEET GAUGE #18, PAINTED

PRODUCED BY AN AUTODESK EDUCATIONAL PRODUCT



TECHNICAL EDUCATION AND SKILLS DEVELOPMENT AUTHORITY

PROJECT TITLE
MOBILE TRAINING LABORATORY

DRAWN BY: JWA

SCALE: 1:15

SHEET NO. 1/1

DETAIL B-1.5:

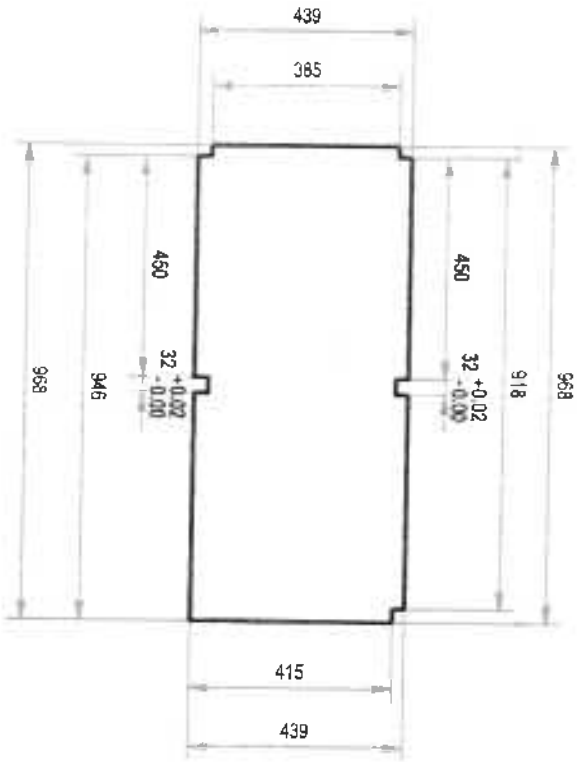

QUANTITY: 1

GALVANIZED SHEET GAUGE #18, PAINTED

DETAIL B-1.6:

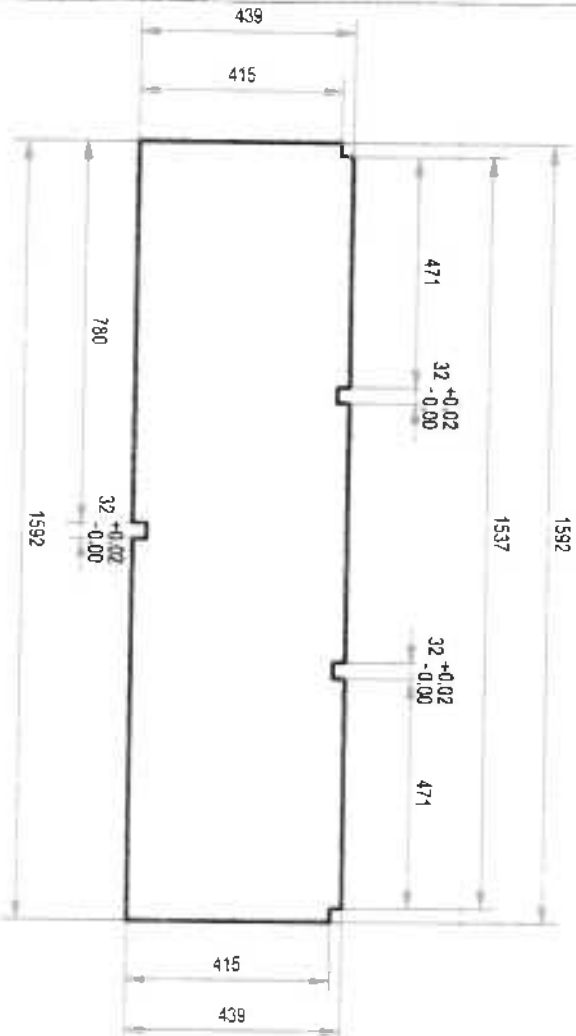

QUANTITY: 2

PRODUCED BY AN AUTODESK EDUCATIONAL PRODUCT



TECHNICAL EDUCATION AND SKILLS DEVELOPMENT AUTHORITY

PROJECT TITLE
MOBILE TRAINING LABORATORY

DRAWN BY: JJA

Scale: 1:15

Drawn No. 1/1

DETAIL D-1.2:

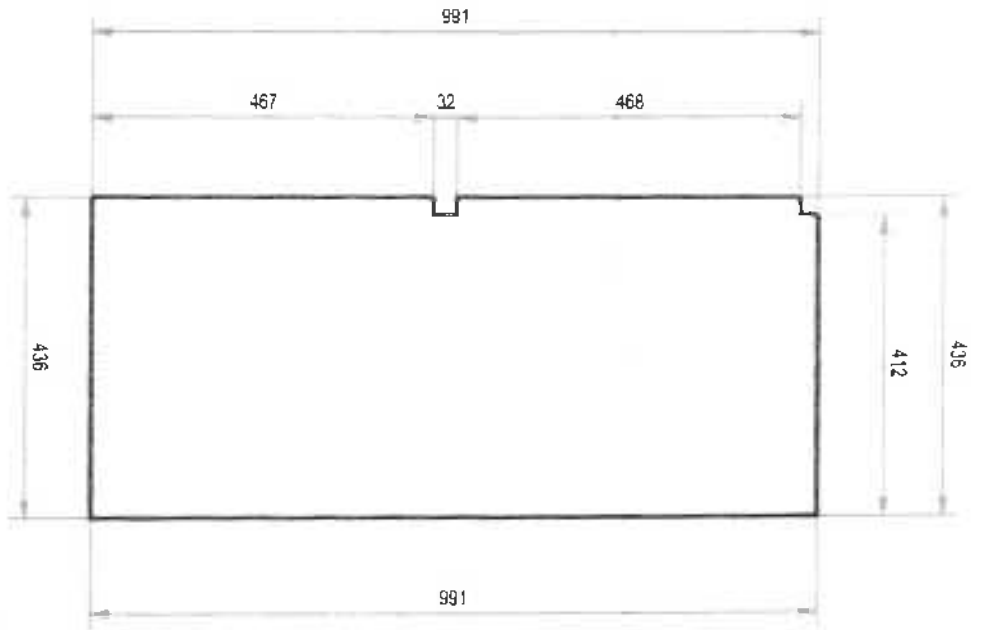

QUANTITY: 1

GALVANIZED SHEET GAUGE #18, PAINTED

PRODUCED BY AN AUTODESK EDUCATIONAL PRODUCT



PROJECT TITLE:
**MOBILE TRAINING
LABORATORY**

DESIGNED BY: JPA Scale: 1:10

DATE: 1/1

B

1/2

dy

pt



A (1 : 10)

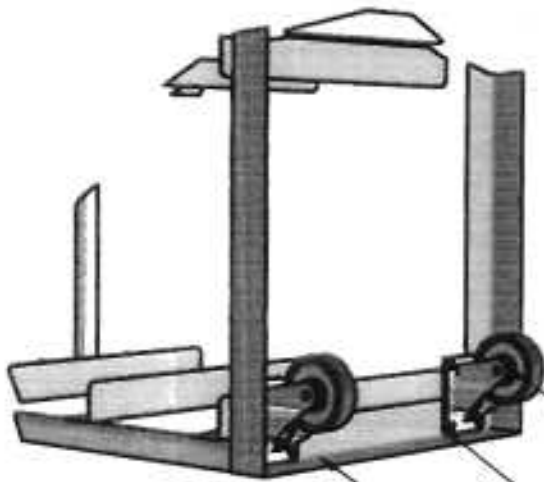

4 pcs. of 4" polyurethane roller wheels with top plate bearing and self-locking; load capacity: 125 lbs. per wheel

Welded in 4" x 4" x 5 mm metal plate

2" x 2" x 3/16" bar, painted



TECHNICAL
EDUCATION AND
SKILLS
DEVELOPMENT
AUTHORITY

PROJECT TITLE
MOBILE TRAINING
LABORATORY

Scale: 1 : 20

1/1

DETAIL F: RUBBER DOOR SEAL

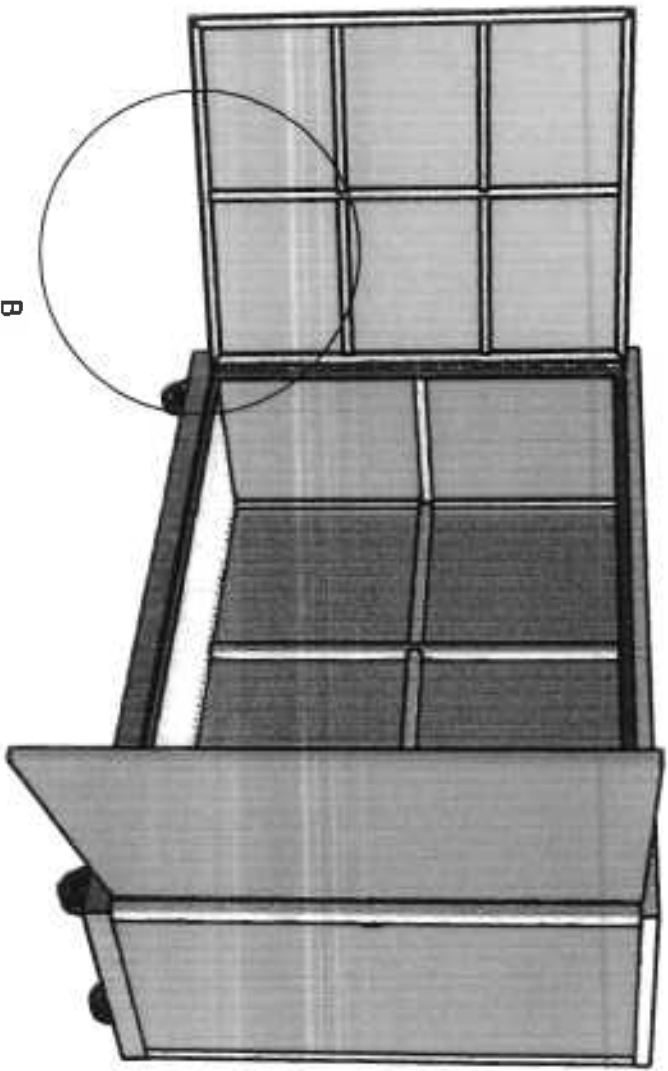

B (1:10)

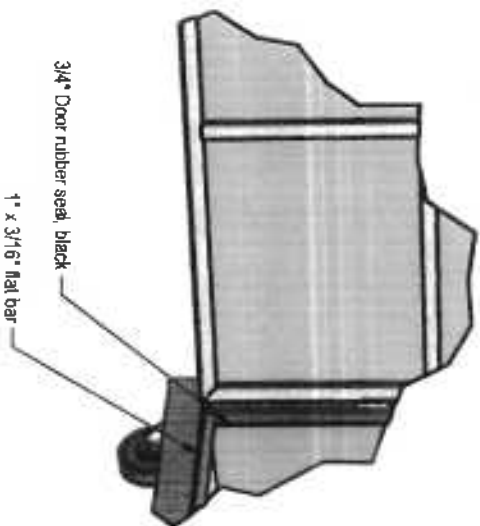

TECHNICAL
EDUCATION AND
SKILLS
DEVELOPMENT
AUTHORITY

PROJECT TITLE
**MOBILE TRAINING
LABORATORY**

DRAWN BY JAA

Scale: 1:25

Sheet No. 1/

| MTL BOX COVER FRAME, SIDEWAY SWING | | | |
|------------------------------------|------------------------------|-------------|------|
| NO. | MATERIAL | LENGTH, mm | Qty. |
| 1 | Gauge #10 G.I. sheet | 1,009 x 835 | 2 |
| 2 | 1" x 1" x 1.5 mm square tube | 968.25 | 4 |
| 3 | 1" x 1" x 1.5 mm square tube | 928.25 | 2 |
| 4 | 1" x 1" x 1.5 mm square tube | 793.65 | 4 |
| 5 | 1" x 1" x 1.5 mm square tube | 359.825 | 8 |
| 6 | 2" x 2mm piano hinge | 968 | 2 |
| TOTAL | | | 22 |

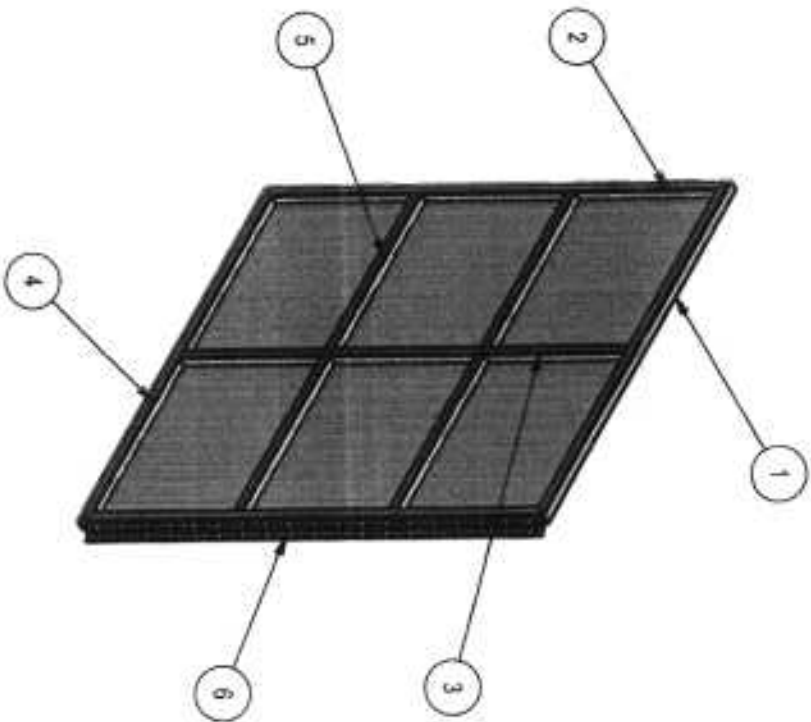

MTL DOOR FRAME



PROJECT TITLE
MOBILE TRAINING
LABORATORY

DRAWN BY: J.A.

SCALE: 1:15

SHEET NO: 1 / 1

2

1

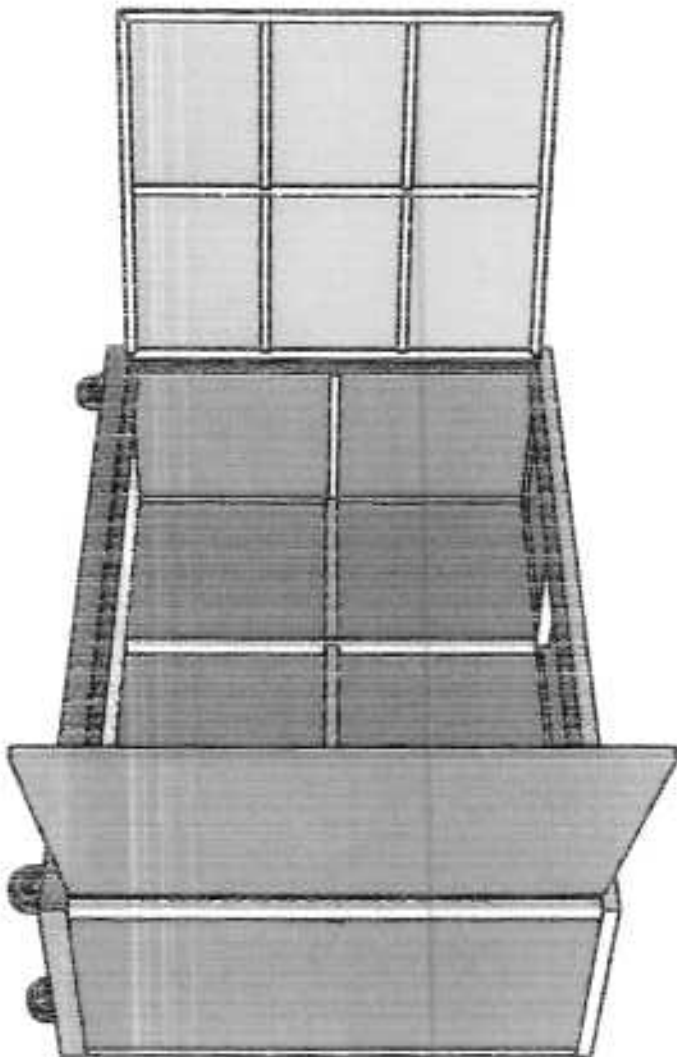

Include 2-sides metal handle
and lock with padlock for the
door (not shown in the drawing)



TECHNICAL
EDUCATION AND
SKILLS
DEVELOPMENT
AUTHORITY

PROJECT TITLE
MOBILE TRAINING
LABORATORY

DATE: 1/1/11

BY: [Signature]

COMPARATIVE TECHNICAL SPECIFICATION

| TESDA'S SPECIFICATIONS | | BIDDER'S SPECIFICATIONS | | |
|------------------------|--|---|------------------|----------------|
| No. | Item | Specifications | Item/Brand/Model | Specifications |
| Lot 8 | Small Engine Repair (Motorcycle/Small Engine Servicing NC II) with Toolbox MTL Box No. 9 | Please refer to the attached drawing | | |
| | Small Engine Repair (Motorcycle/Small Engine Servicing NC II) with Toolbox MTL Box No. 10 | Please refer to the attached drawing | | |

Name of Bidder: _____

Name and Signature of Authorized Representative: _____
 Position/Designation: _____
 Date: _____

Handwritten initials and marks: *1*, *9/2*, *OK*

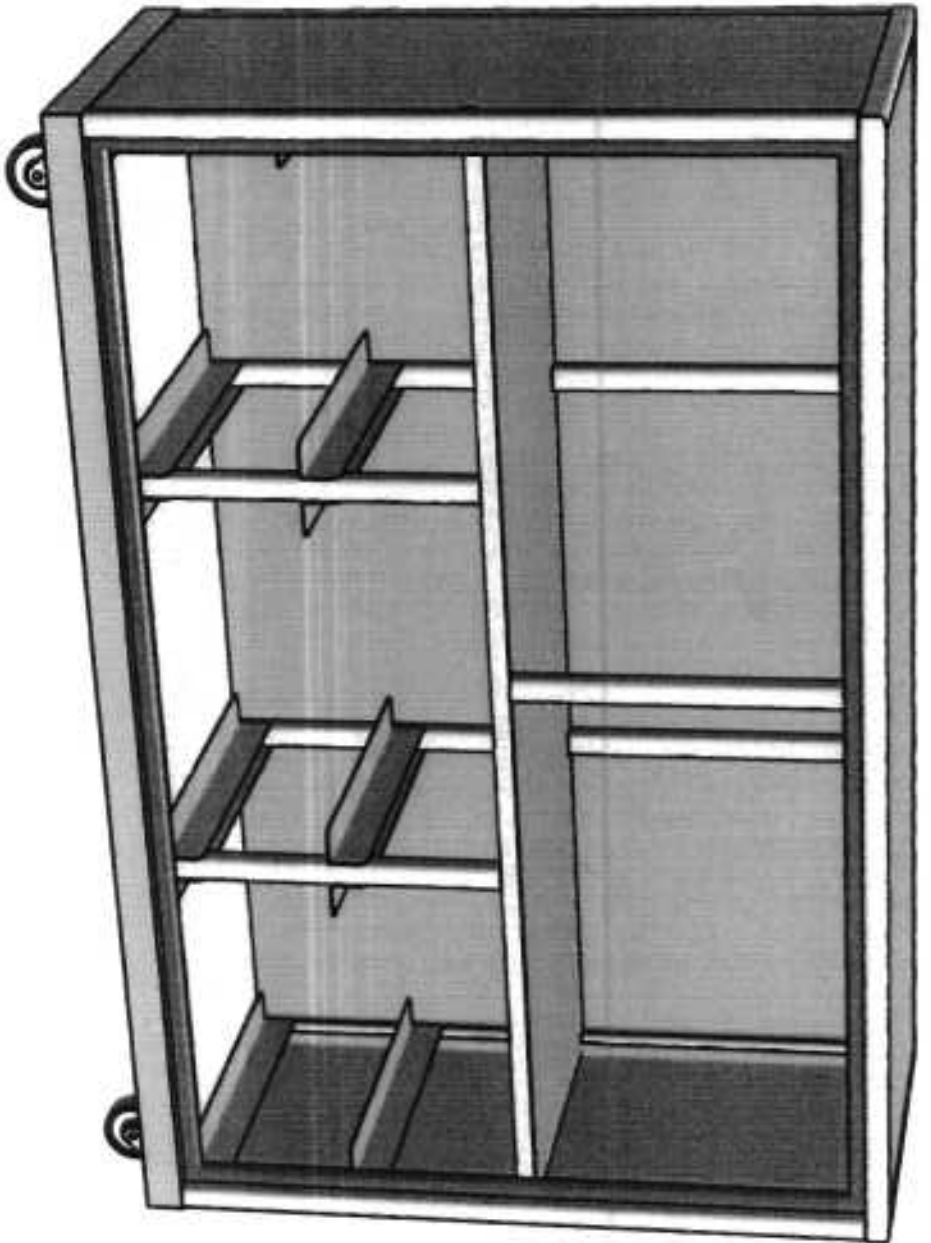

**MTL BOX NO. 9
(SMALL ENGINE REPAIR)
QUANTITY:**
(The door is not shown in the drawing)

PRODUCED BY AN AUTODESK EDUCATIONAL PRODUCT



TECHNICAL
EDUCATION AND
SKILLS
DEVELOPMENT
AUTHORITY

PROJECT TITLE:
**MOBILE TRAINING
LABORATORY**

TN

Drawing No. JVA

Scale: 1:10

Sheet No. 1/1

| MTL BOX 9 FRAME | | | |
|-----------------|---|------------|------|
| NO. | MATERIAL | LENGTH, mm | QTY. |
| 1 | 2" x 2" x 3/16" angle bar | 1,800.00 | 2 |
| 2 | 2" x 2" x 3/16" angle bar | 500.00 | 2 |
| 3 | 1 1/4" x 1 1/4" x 2 mm square tube | 493.85 | 2 |
| 4 | 1 1/4" x 1 1/4" x 2 mm square tube | 968.25 | 6 |
| 5 | 1 1/4" x 1 1/4" x 2 mm square tube | 1,800.00 | 2 |
| 6 | 1 1/4" x 1 1/4" x 2 mm square tube | 500.00 | 2 |
| 7 | 1 1/4" x 1 1/4" x 2 mm square tube | 436.50 | 2 |
| 8 | 1 1/4" x 1 1/4" x 2 mm square tube | 1,473.00 | 1 |
| 9 | 1 1/4" x 1 1/4" x 2 mm square tube | 475.00 | 2 |
| 10 | 1 1/4" x 1 1/4" x 2 mm square tube | 467.04 | 1 |
| 11 | 1 1/4" x 1 1/4" x 2 mm square tube | 50.00 | 1 |
| 12 | 1" x 1" x 1.5 mm square tube | 436.50 | 2 |
| 13 | 1" x 1" x 1.5 mm square tube | 475.00 | 2 |
| 14 | 1" x 1" x 1.5 mm square tube | 1,547.58 | 1 |
| 15 | 1" x 1" x 1.5 mm square tube | 392.04 | 2 |
| 16 | Gauge #18 GI steel, 2" x 2" @ 90 degrees bend | 431.70 | 12 |
| TOTAL | | | 42 |

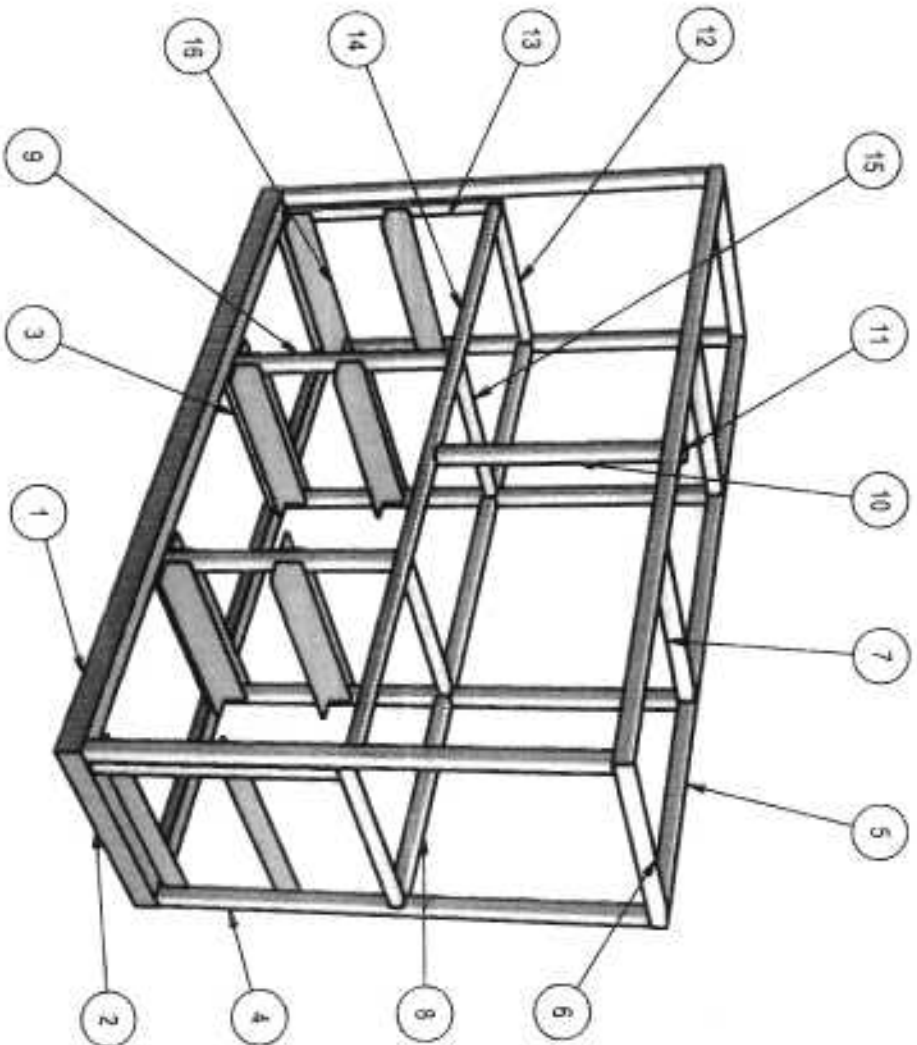

**MTL BOX NO. 9 FRAME
(SMALL ENGINE REPAIR)**



TECHNICAL
EDUCATION AND
SKILLS
DEVELOPMENT
AUTHORITY

PROJECT TITLE
**MOBILE TRAINING
LABORATORY**

Drawing No. 115

Scale 1:15

Sheet No. 1/1

- MTL BOX NO. 9**
- ☒ All materials must be painted with anti-corrosive primer
 - ☐ Tube and \angle bar are coated with light gray epoxy finish paint

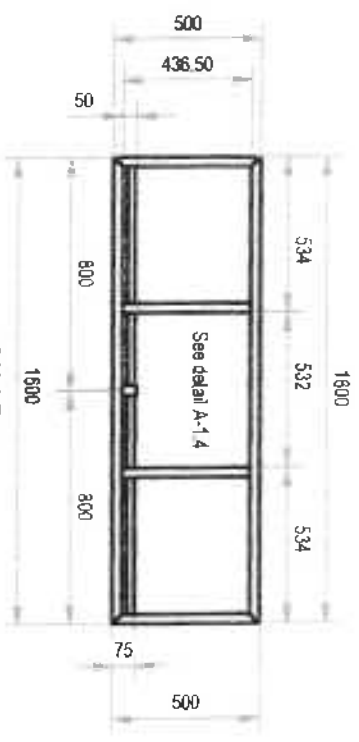

TOP VIEW

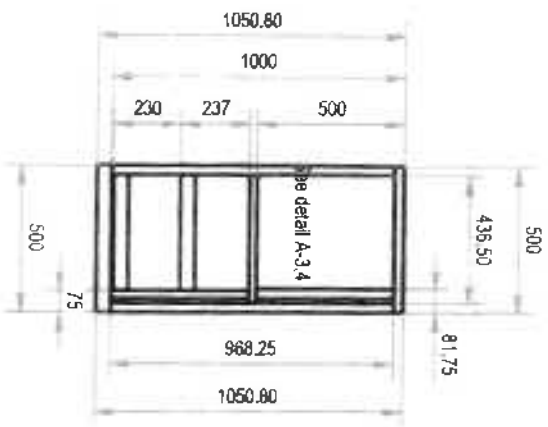

LEFT SIDE VIEW

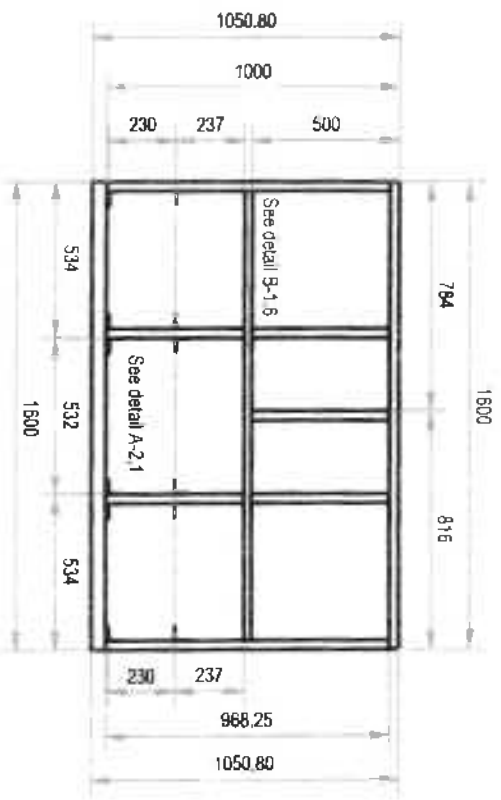

FRONT VIEW

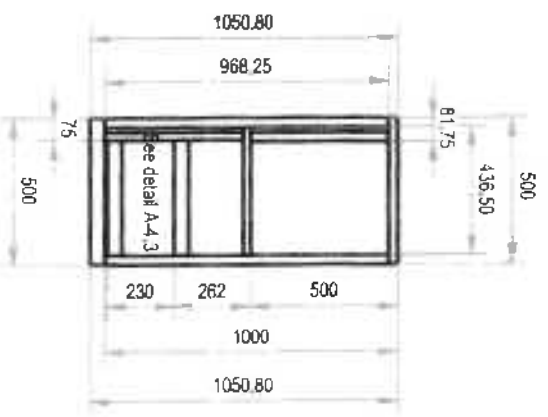

RIGHT SIDE VIEW

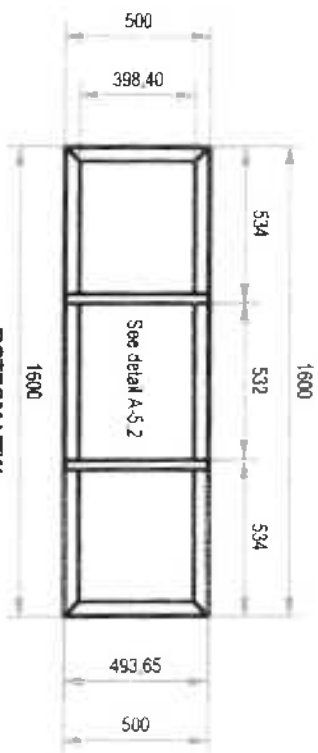

BOTTOM VIEW

**MTL BOX NO. 9 FRAME
(SMALL ENGINE REPAIR)**
(The door is not shown in the drawing)



TECHNICAL
EDUCATION AND
SKILLS
DEVELOPMENT
AUTHORITY

PROJECT TITLE
**MOBILE TRAINING
LABORATORY**

DESIGN BY: JSA
Scale: 1/25
Sheet No: 1/1

afg
pd

DETAIL A-1.1:

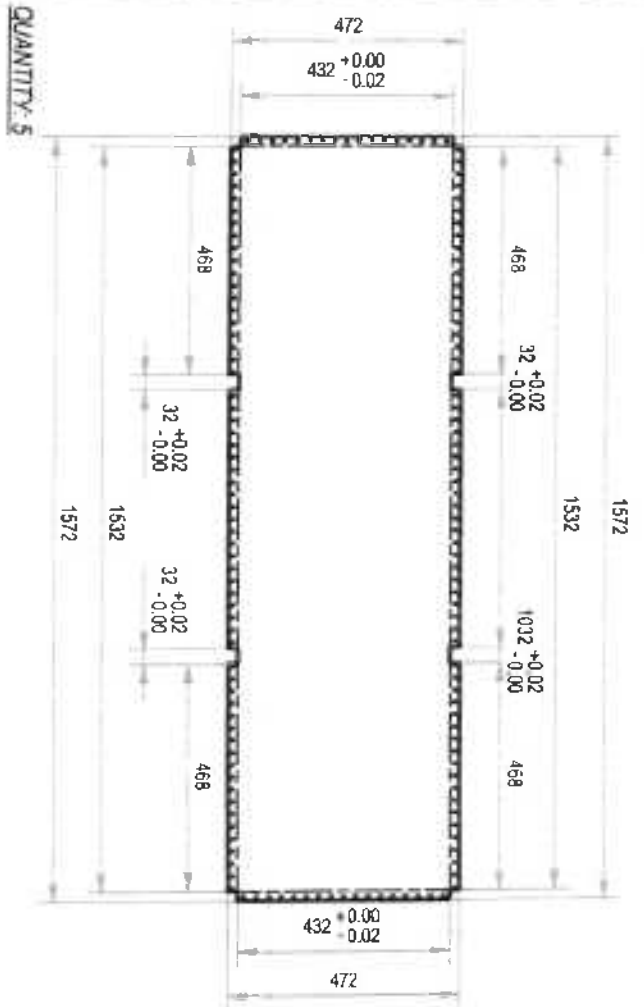

DETAIL A-1.3:

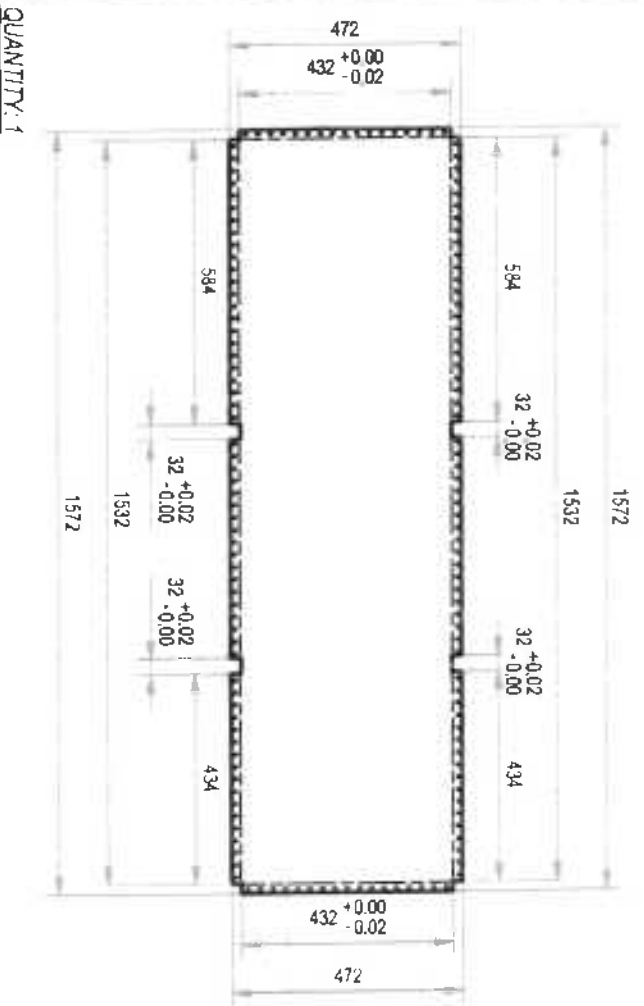

DETAIL A-1.2:

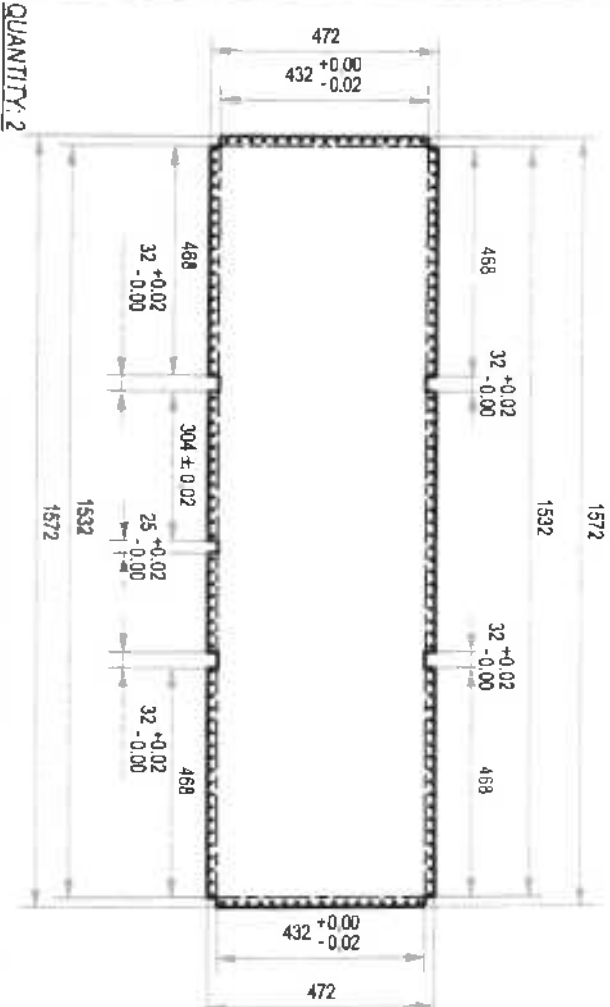

DETAIL A-1.4:

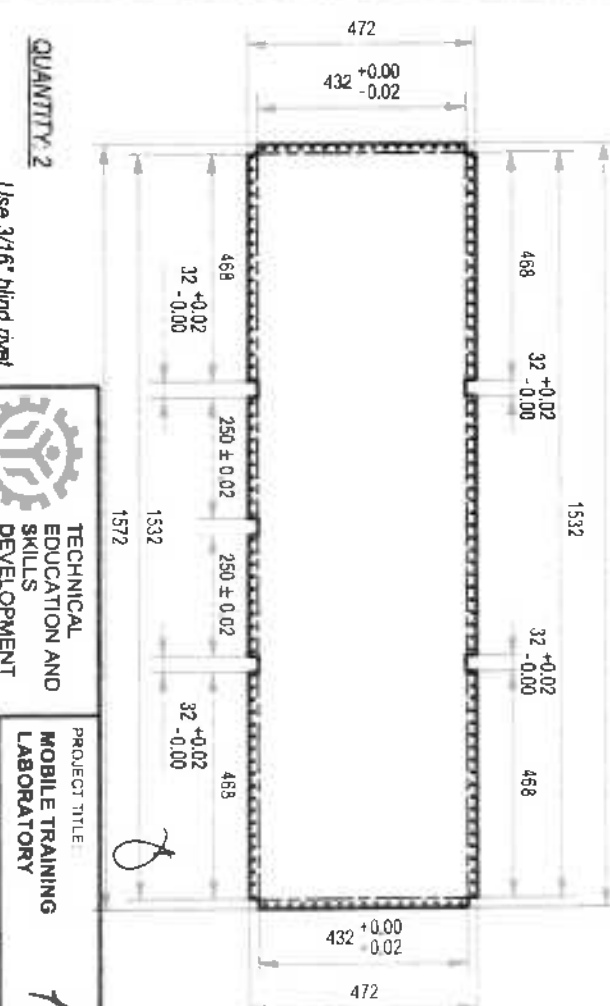

QUANTITY: 2

QUANTITY: 5

QUANTITY: 2

QUANTITY: 1

FLAT PATTERN: GALVANIZED SHEET GAUGE #18, PAINTED

Use 3/16" blind rivet spaced @ 1" O.C.



TECHNICAL EDUCATION AND SKILLS DEVELOPMENT AUTHORITY

PROJECT TITLE: MOBILE TRAINING LABORATORY

Scale: 1/15

DETAIL A-2.2:

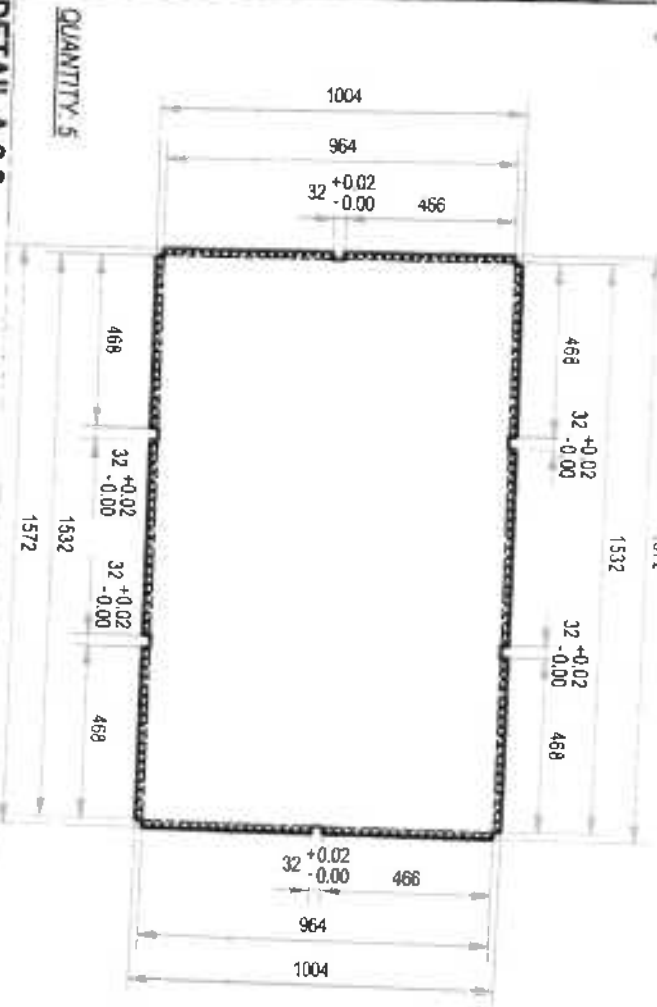

QUANTITY: 5

QUANTITY: 2

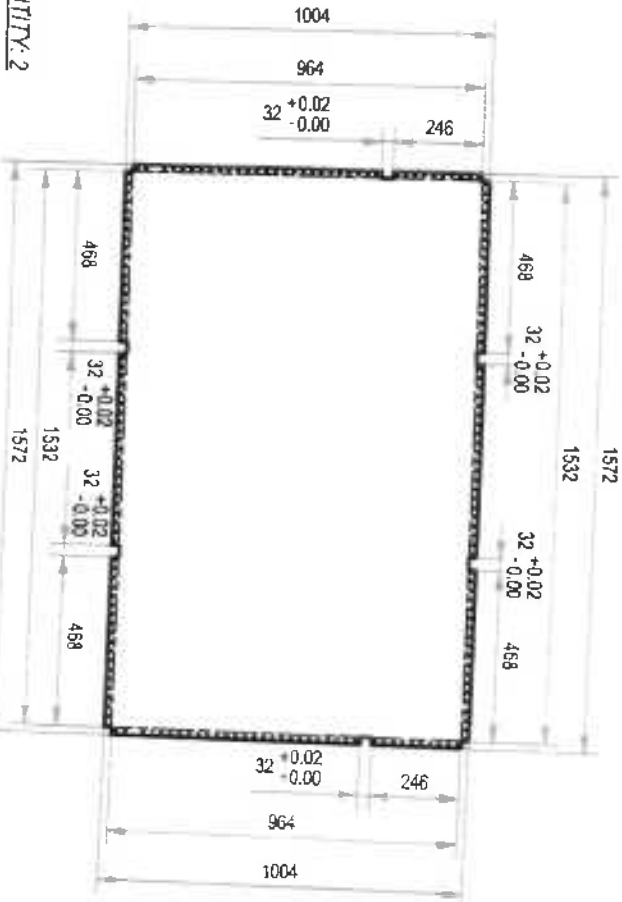

FLAT PATTERN: GALVANIZED SHEET GAUGE #18, PAINTED

DETAIL A-2.4:

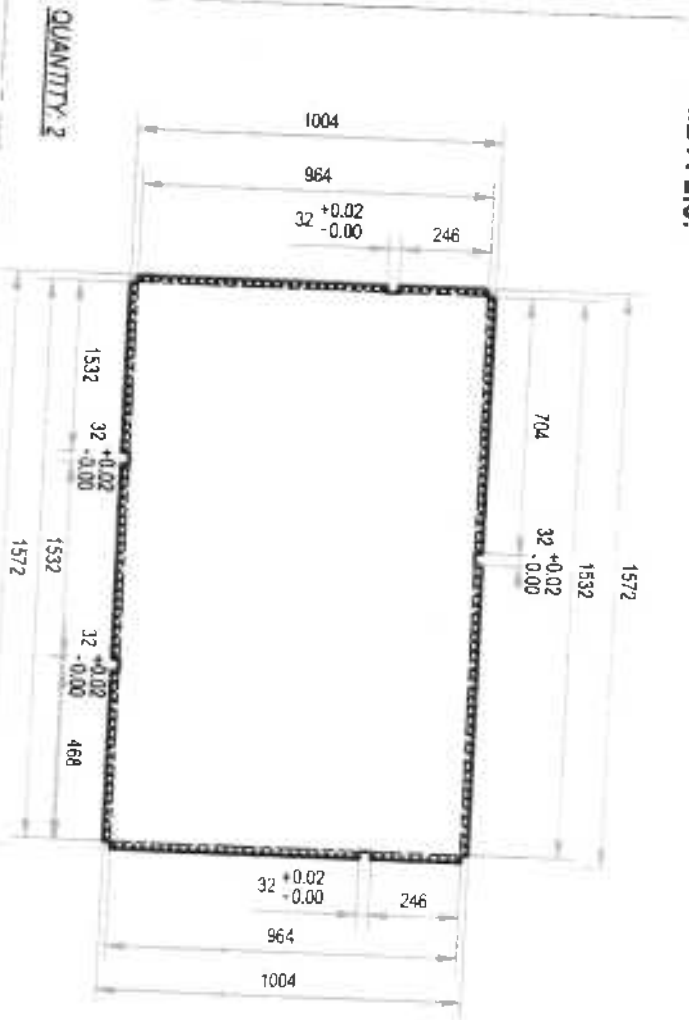

QUANTITY: 2

QUANTITY: 1

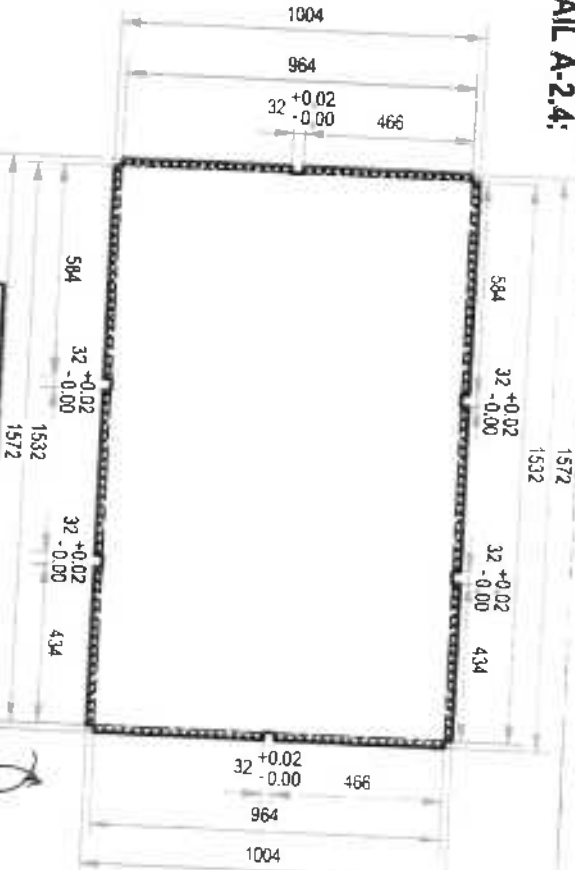

Use 3/8" blind rivet spaced @ 1" O.C.



TECHNICAL EDUCATION AND SKILLS DEVELOPMENT AUTHORITY

PROJECT TITLE

MOBILE TRAINING LABORATORY

Drawn by: JA

Scale: 1:20

Sheet No: 1/1

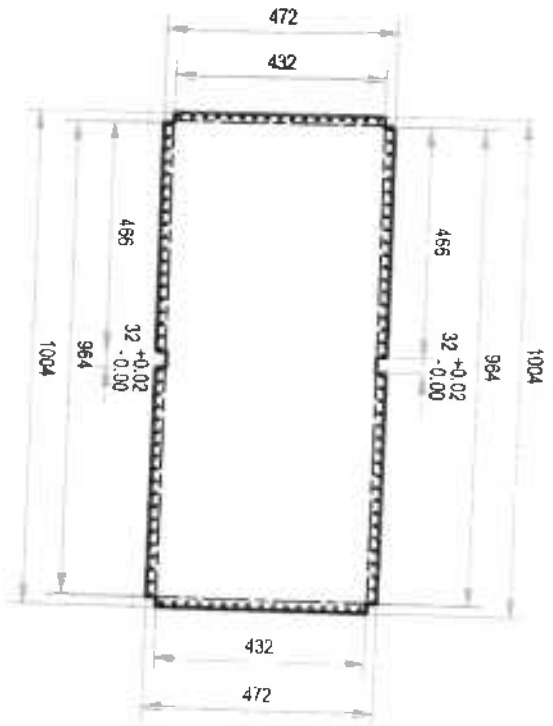

QUANTITY: 5

DETAIL A-3.2:



QUANTITY: 4

FLAT PATTERN: GALVANIZED SHEET GAUGE #18, PAINTED

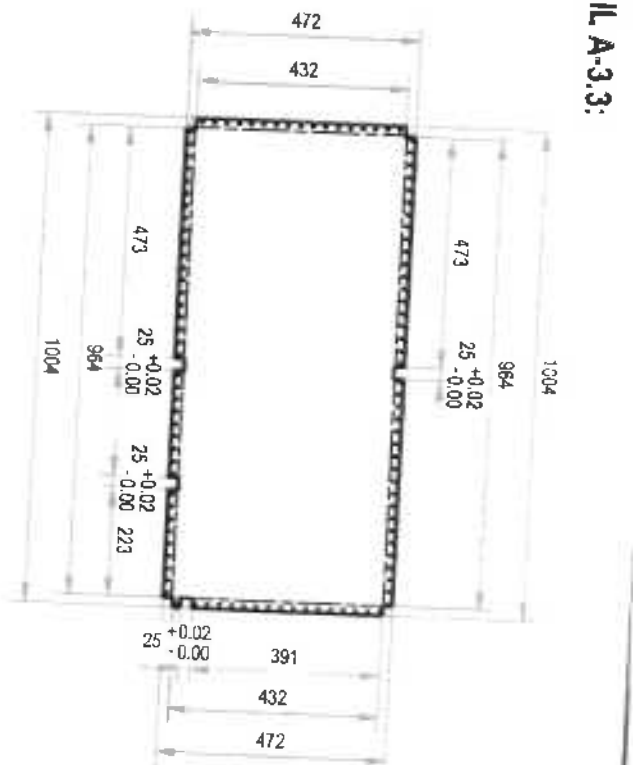

QUANTITY: 1

DETAIL A-3.4:



QUANTITY: 2

Use 3/16" blind rivet spaced @ 1" O.C.

PRODUCED BY AN AUTODESK EDUCATIONAL PRODUCT



TECHNICAL EDUCATION AND SKILLS DEVELOPMENT AUTHORITY

PROJECT TITLE
MOBILE TRAINING LABORATORY

DRAWN BY: JVA SCALE: 1:1.5

1/

DETAIL A-4.1:



QUANTITY: 4

DETAIL A-4.2:

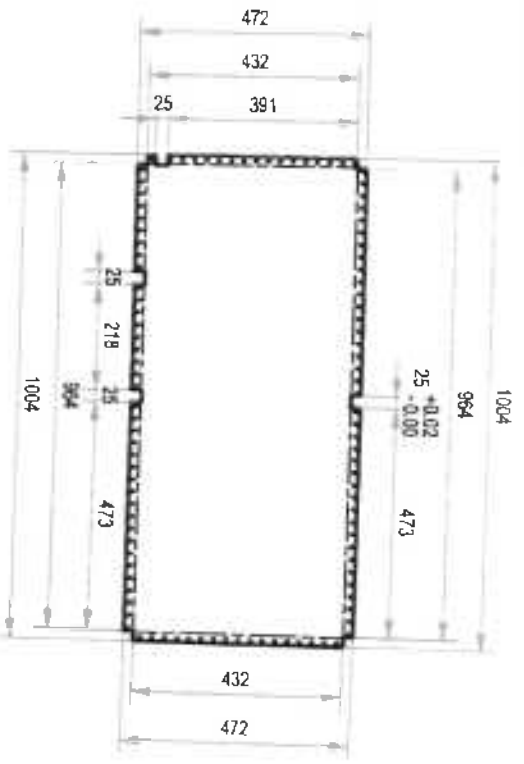

QUANTITY: 2

DETAIL A-4.3:

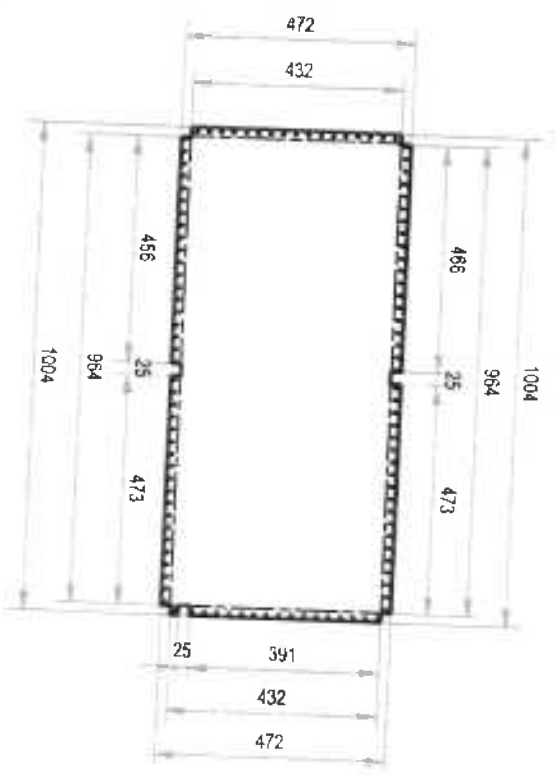

QUANTITY: 2

FLAT PATTERN: GALVANIZED SHEET GAUGE #18, PAINTED

Use 3/16" blind rivet spaced @ 1" O.C.



PROJECT TITLE
MOBILE TRAINING LABORATORY

ORIGINATOR: JSA
Scale: 1:15

PRODUCED BY AN AUTODESK EDUCATIONAL PRODUCT

DETAIL A-5.1:

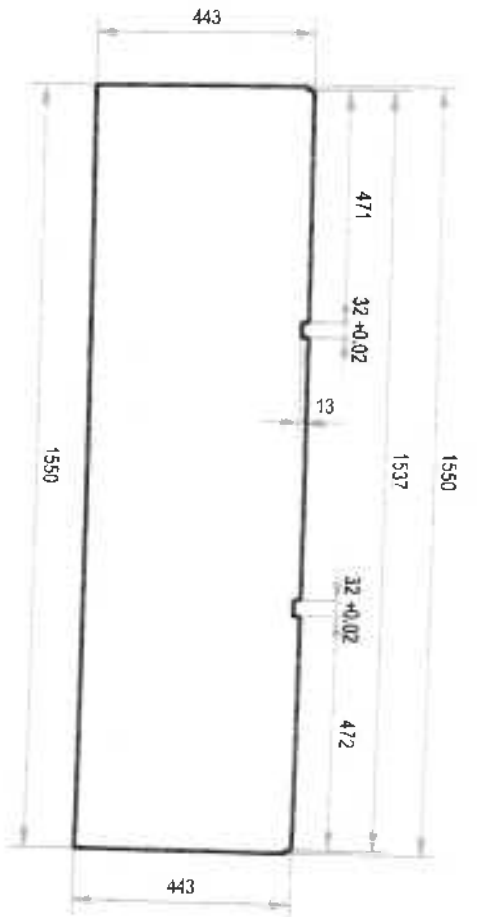

QUANTITY: 1

DETAIL A-5.2:

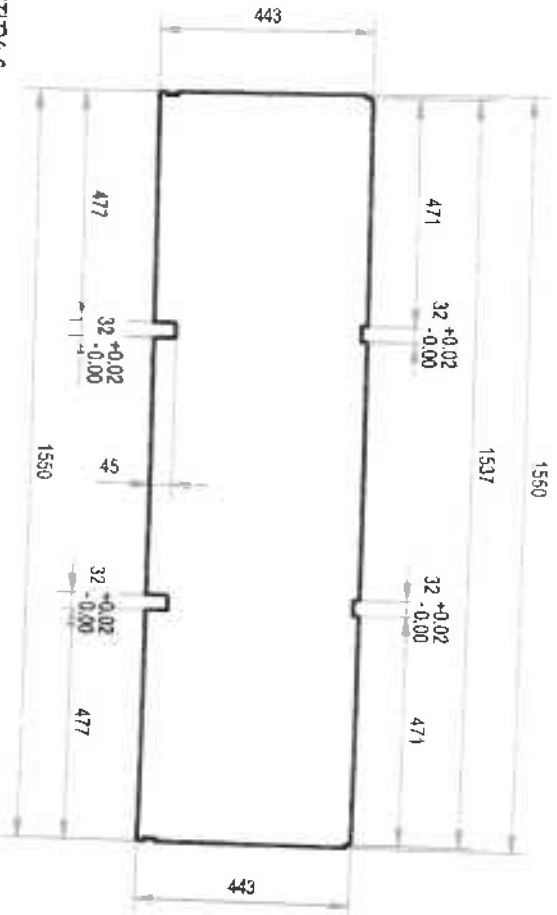

QUANTITY: 6

GALVANIZED SHEET GAUGE #18, PAINTED

PRODUCED BY AN AUTODESK EDUCATIONAL PRODUCT

DETAIL A-5.3:

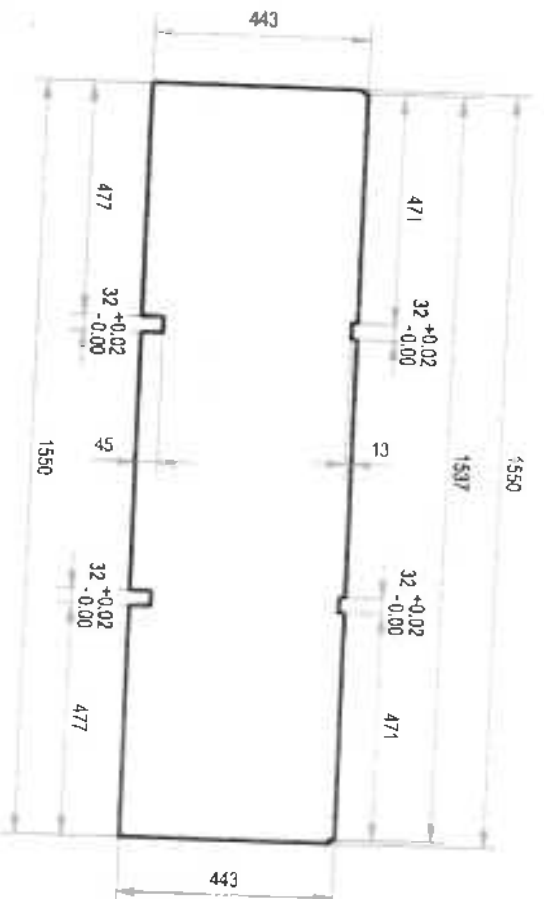

QUANTITY: 2

DETAIL A-5.4:

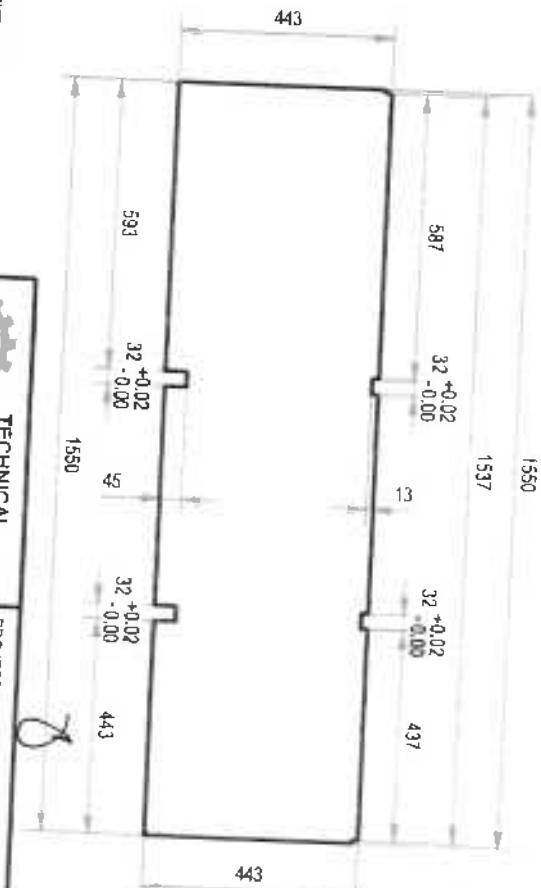

QUANTITY: 1



PROJECT TITLE
MOBILE TRAINING LABORATORY

Scale: 1:15

AKS

DETAIL B-1.5:

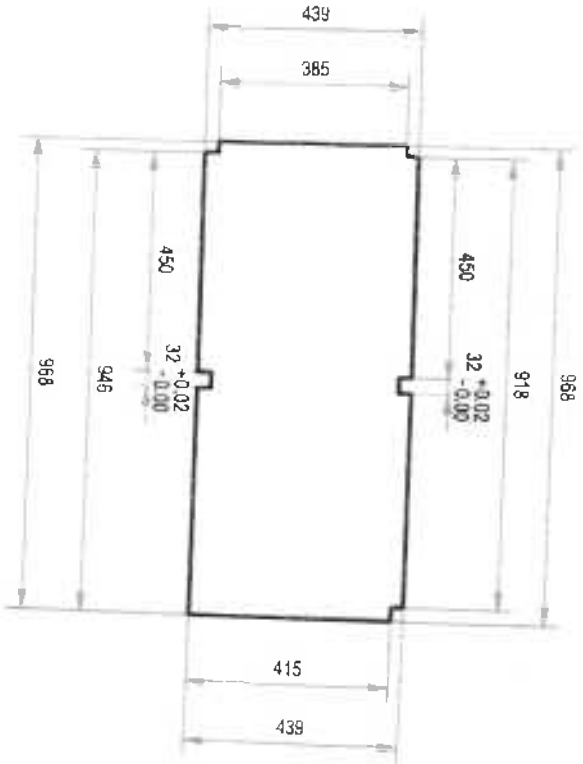

QUANTITY: 1

GALVANIZED SHEET GAUGE #18, PAINTED

DETAIL B-1.6:

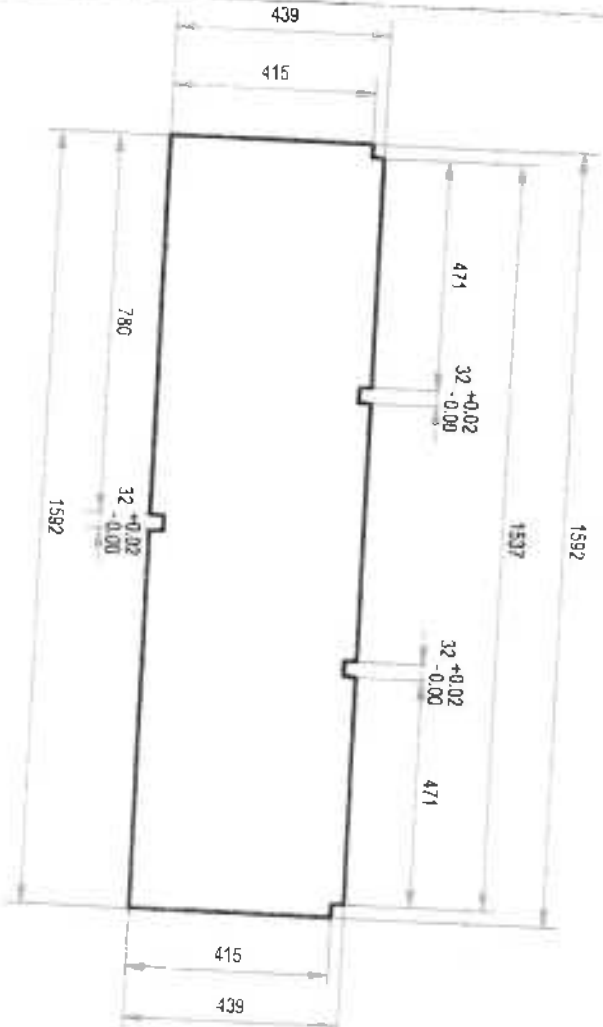

QUANTITY: 2

PRODUCED BY AN AUTODESK EDUCATIONAL PRODUCT



TECHNICAL EDUCATION AND SKILLS DEVELOPMENT AUTHORITY

PROJECT TITLE
MOBILE TRAINING LABORATORY

Scale: 1:15

Sheet No. 1 /

Handwritten initials and marks.

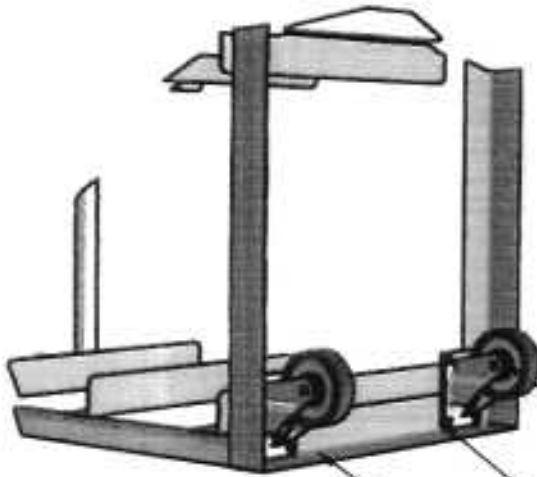

A (1 : 10)

4 pcs. of 4" polyurethane roller wheels with top plate bearing and self-locking; load capacity: 125 lbs. per wheel

Welded in 4" x 4" x 5 mm metal plate

2" x 2" x 3/16" bar, painted



TECHNICAL EDUCATION AND SKILLS DEVELOPMENT AUTHORITY

PROJECT TITLE
MOBILE TRAINING LABORATORY

DRAWN BY: JPA

Scale: 1:20

Sheet No. 1/1

DETAIL F: RUBBER DOOR SEAL

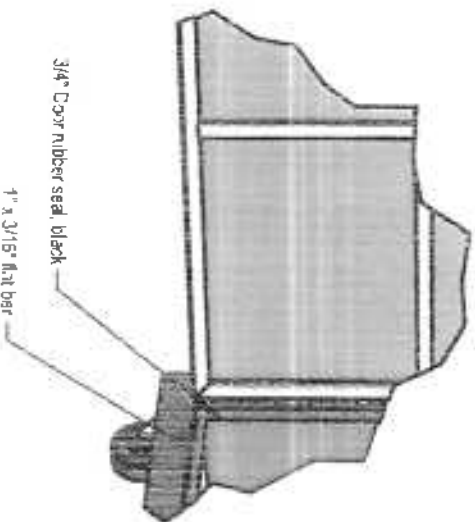
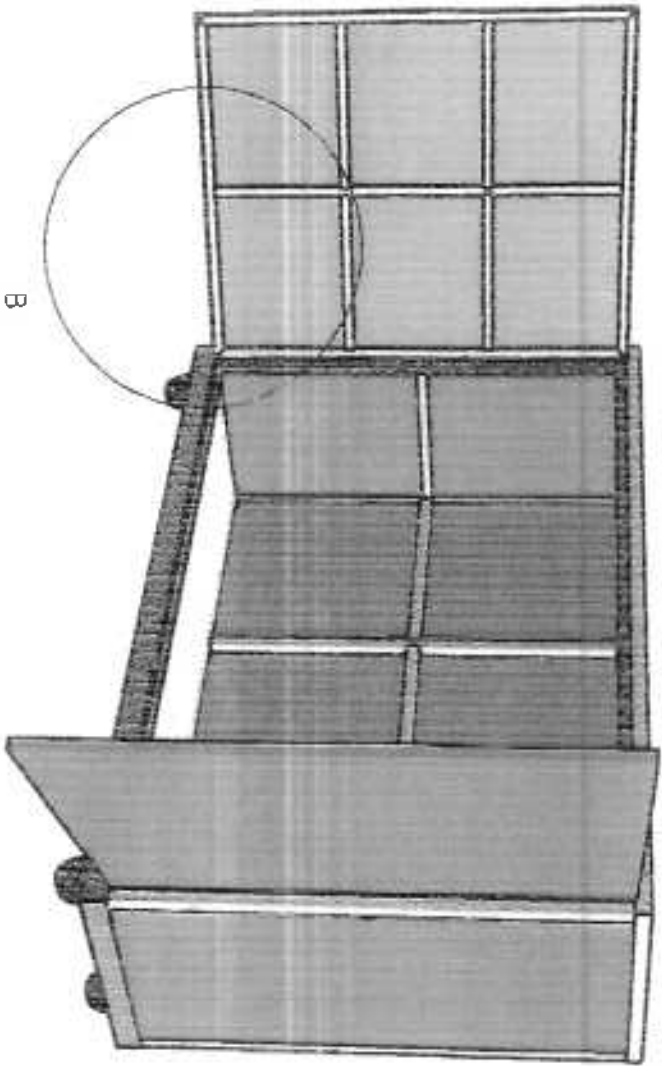

B (1:10)



TECHNICAL EDUCATION AND SKILLS DEVELOPMENT AUTHORITY

PROJECT TITLE
MOBILE TRAINING LABORATORY

Scale: 1:25

1/2

| MTL BOX COVER FRAME, SIDEWAY SWING | | | |
|------------------------------------|------------------------------|-------------|------|
| NO. | MATERIAL | LENGTH, mm | Qty. |
| 1 | Gauge #18 G.I. sheet | 1,009 x 835 | 2 |
| 2 | 1" x 1" x 1.5 mm square tube | 968,25 | 4 |
| 3 | 1" x 1" x 1.5 mm square tube | 928,25 | 2 |
| 4 | 1" x 1" x 1.5 mm square tube | 793,65 | 4 |
| 5 | 1" x 1" x 1.5 mm square tube | 389,825 | 8 |
| 6 | 2" x 2mm piano hinge | 968 | 2 |
| TOTAL | | | 22 |

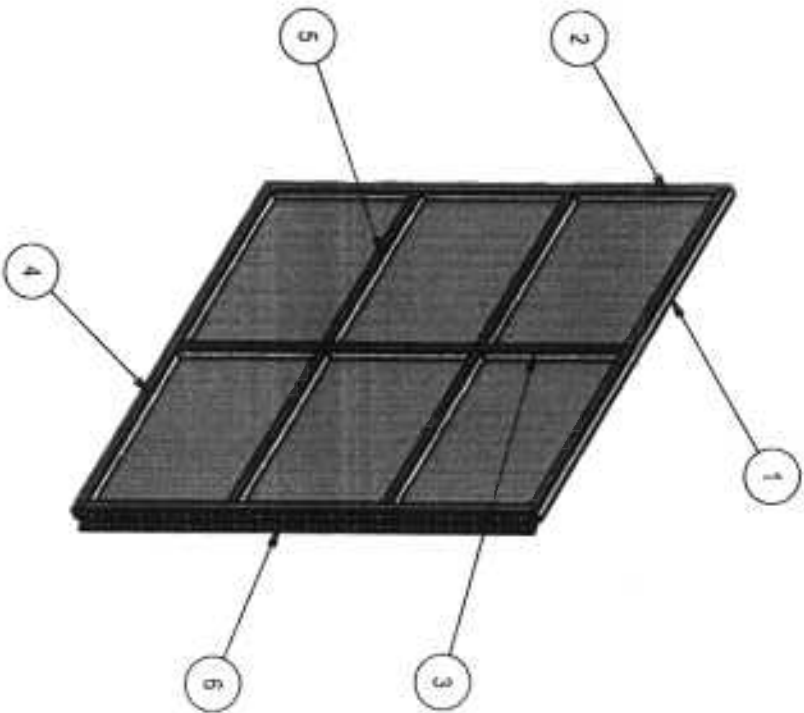

MTL DOOR FRAME

| | | |
|---|---------------------------------------|-------------|
| <p>TECHNICAL EDUCATION AND SKILLS DEVELOPMENT AUTHORITY</p> | PROJECT TITLE | |
| | <p>MOBILE TRAINING LABORATORY</p> | Scale: 1:15 |
| <p>DESIGNED BY: JSA</p> | <p>DATE: 1/15</p> | <p>1/1</p> |

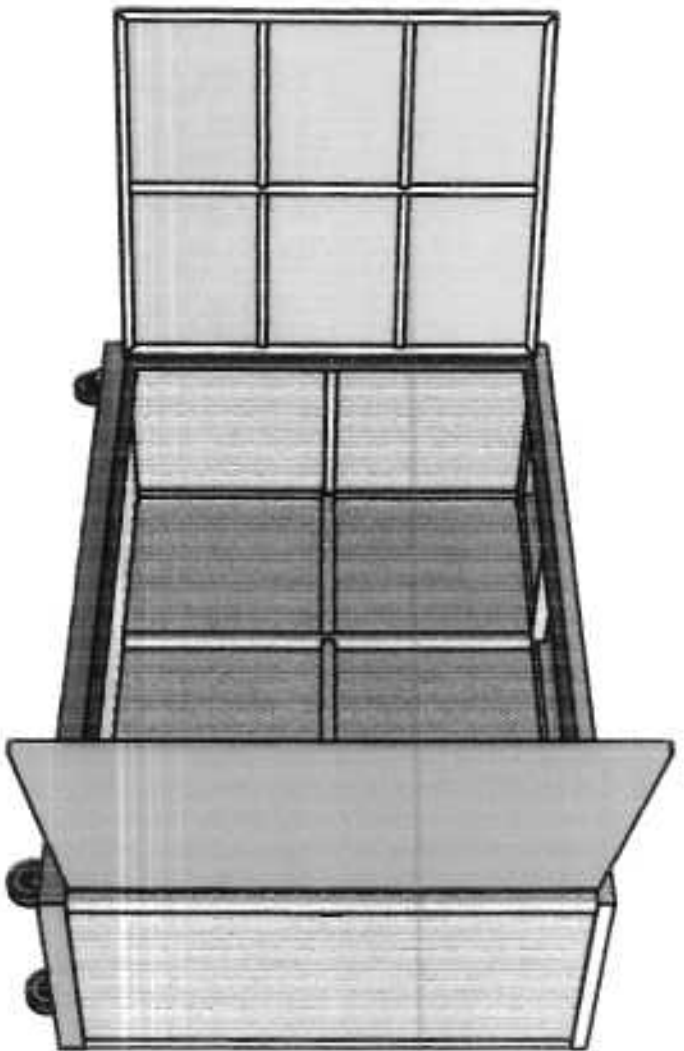

Include 2-sides metal handle
and lock with padlock for the
door (not shown in the drawing)



TECHNICAL
EDUCATION AND
SKILLS
DEVELOPMENT
AUTHORITY

PROJECT TITLE:
**MOBILE TRAINING
LABORATORY**

7M

DRAWN BY: JKA

Scale 1:15

Sheet No.
1/1

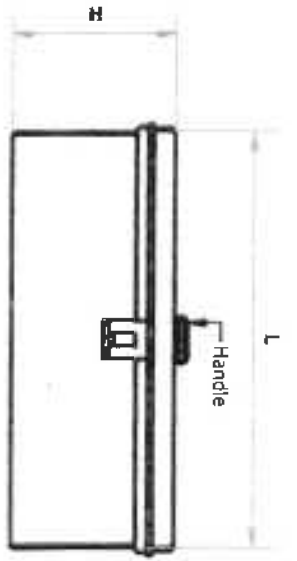

FRONT VIEW

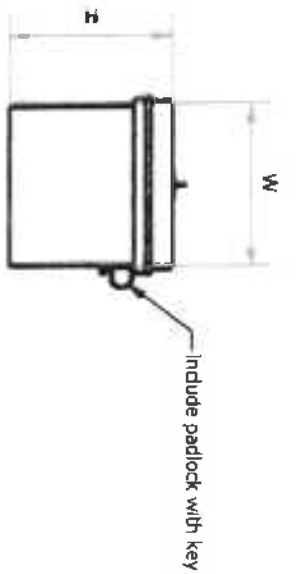

SIDE VIEW

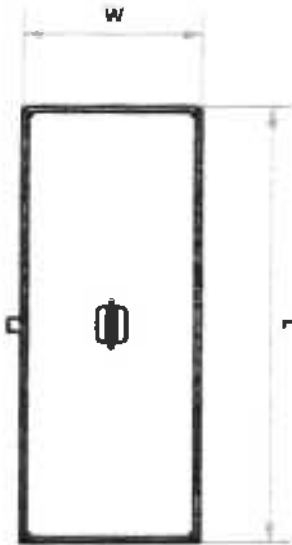

TOP VIEW

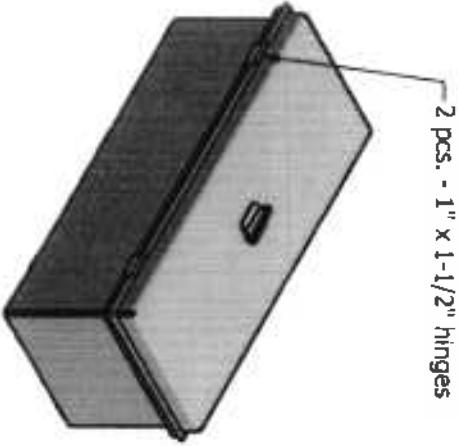

ISOMETRIC VIEW

| TOOLBOX | | |
|---------|-----------------------|--|
| NO. | DIMENSION (L x W x H) | MATERIAL |
| 1 | 18" x 7" x 7" | Small Engine Repair - G.A., #18 galvanized sheet, painted |
| 3 | 18" x 7" x 8" | Appliance Repair - G.A. #18 galvanized sheet, painted |
| | 18" x 7" x 8" | Electrical Installation and Maintenance - G.A. #18 galvanized sheet, painted |
| 4 | 20" x 7" x 8" | Small Engine Repair - G.A. #18 galvanized sheet, painted |
| 5 | 16" x 20" x 4-1/2" | Cookery - Plastic, white |
| 6 | 16" x 20" x 4-1/2" | Food Processing - Plastic, white |



TECHNICAL
EDUCATION AND
SKILLS
DEVELOPMENT
AUTHORITY

PROJECT TITLE

COMPACT MOBILE UNIT

DESIGNED BY: JVA

SCALE: 1:1

SHEET NO. 1/1

Handwritten initials

Handwritten initials

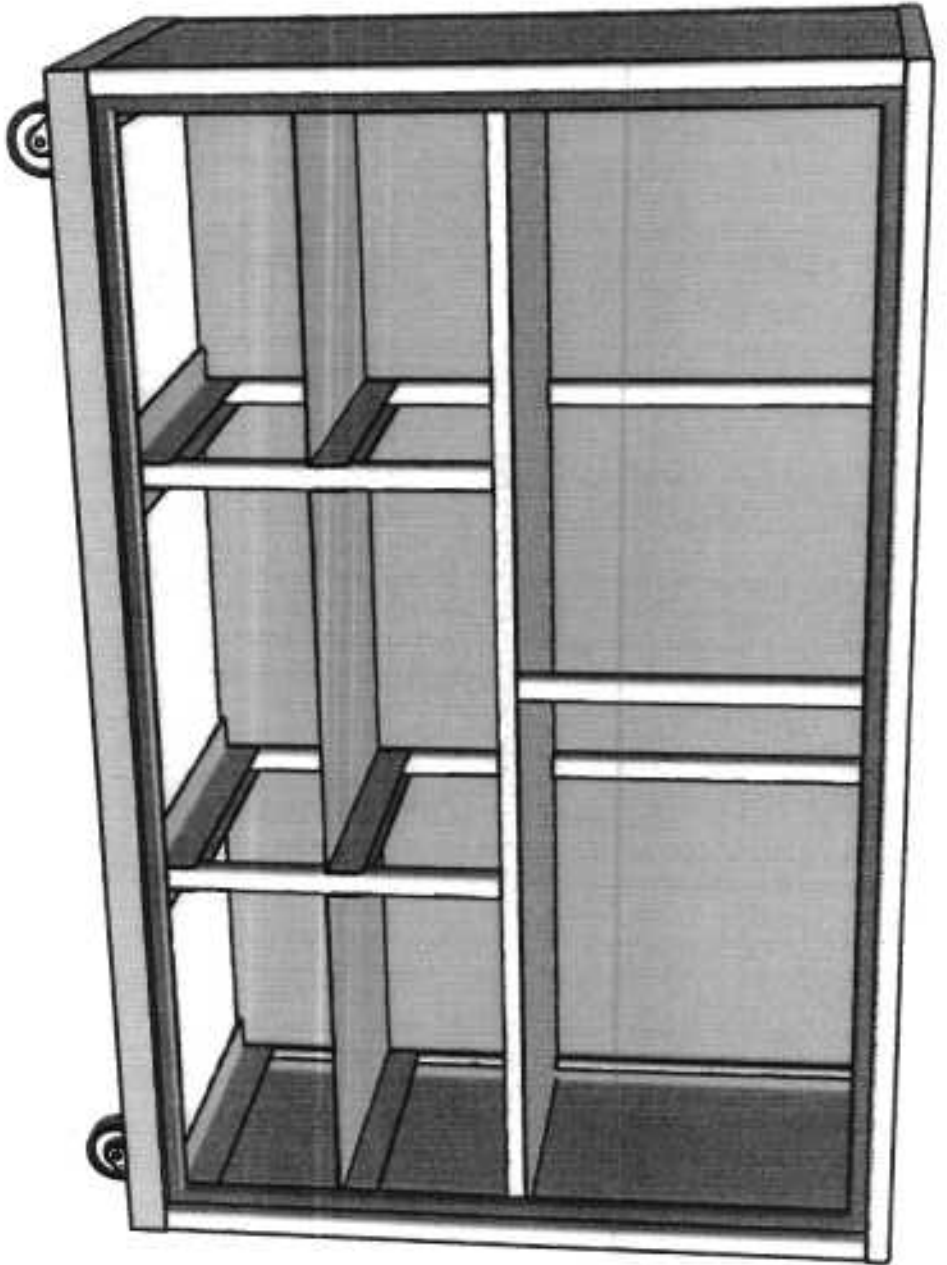

MTL BOX NO. 10
(SMALL ENGINE REPAIR)
QUANTITY:
(The door is not shown in the drawing)

PRODUCED BY AN AUTODESK EDUCATIONAL PRODUCT



**TECHNICAL
EDUCATION AND
SKILLS
DEVELOPMENT
AUTHORITY**

PROJECT TITLE
**MOBILE TRAINING
LABORATORY**

Drawn by: JNA

Scale: 1/10

Sheet No:
1/1

| MTL BOX 10 FRAME | | | |
|------------------|---|------------|------|
| NO. | MATERIAL | LENGTH, mm | Qty. |
| 1 | 2" x 2" x 3/16" angle bar | 1,600.00 | 2 |
| 2 | 2" x 2" x 3/16" angle bar | 500.00 | 2 |
| 3 | 1 1/4" x 1 1/4" x 2 mm square tube | 493.65 | 2 |
| 4 | 1 1/4" x 1 1/4" x 2 mm square tube | 968.25 | 6 |
| 5 | 1 1/4" x 1 1/4" x 2 mm square tube | 1,500.00 | 2 |
| 6 | 1 1/4" x 1 1/4" x 2 mm square tube | 500.00 | 2 |
| 7 | 1 1/4" x 1 1/4" x 2 mm square tube | 436.50 | 2 |
| 8 | 1 1/4" x 1 1/4" x 2 mm square tube | 1,473.00 | 1 |
| 9 | 1 1/4" x 1 1/4" x 2 mm square tube | 475.00 | 2 |
| 10 | 1 1/4" x 1 1/4" x 2 mm square tube | 467.04 | 1 |
| 11 | 1 1/4" x 1 1/4" x 2 mm square tube | 50.00 | 1 |
| 12 | 1" x 1" x 1.5 mm square tube | 436.50 | 2 |
| 13 | 1" x 1" x 1.5 mm square tube | 475.00 | 2 |
| 14 | 1" x 1" x 1.5 mm square tube | 1,547.58 | 1 |
| 15 | 1" x 1" x 1.5 mm square tube | 392.04 | 2 |
| 16 | Gauge #18 GI sheet, 2" x 2" @ 90 degreat bend | 431.70 | 12 |
| TOTAL | | | 42 |

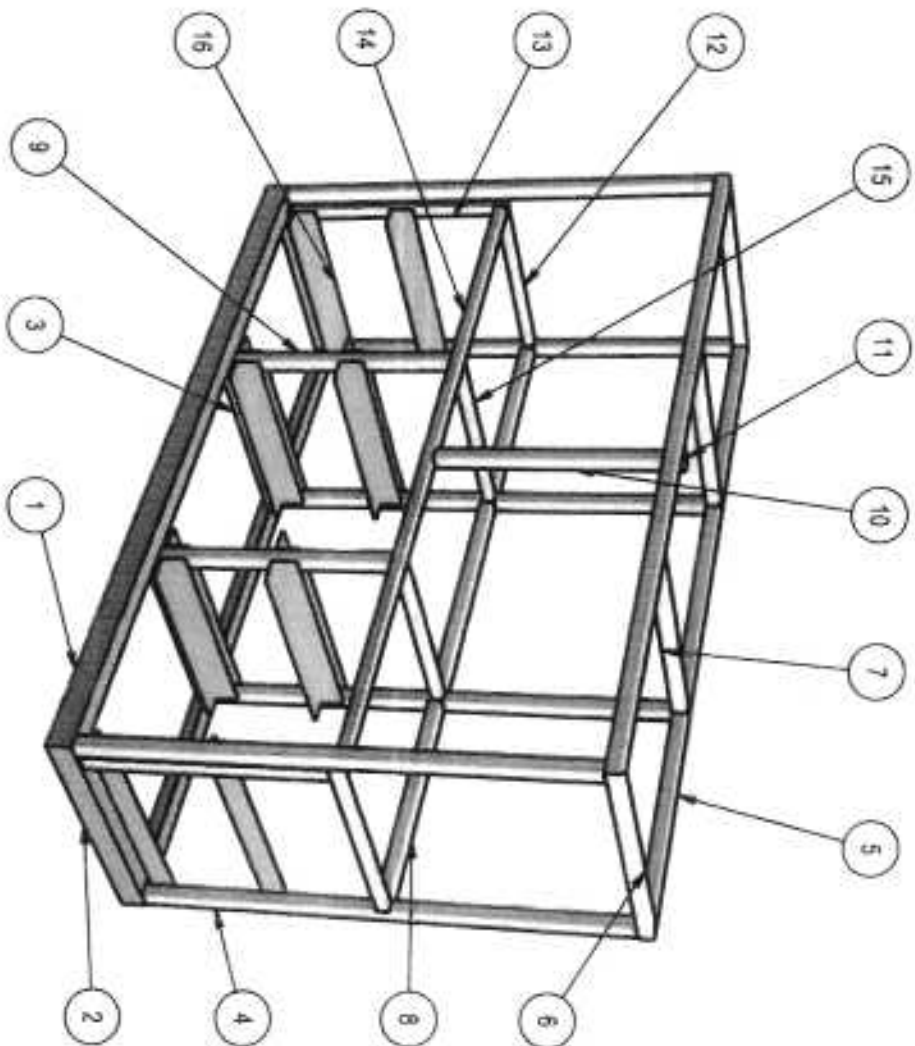

MTL BOX NO. 10 FRAME
(SMALL ENGINE REPAIR)
 (The door is not shown in the drawing)

8

7N

MTL BOX NO. 10
 ☒ All materials must be painted with anti-corrosive primer
 ☒ tube and bar are coated with light gray epoxy finish paint

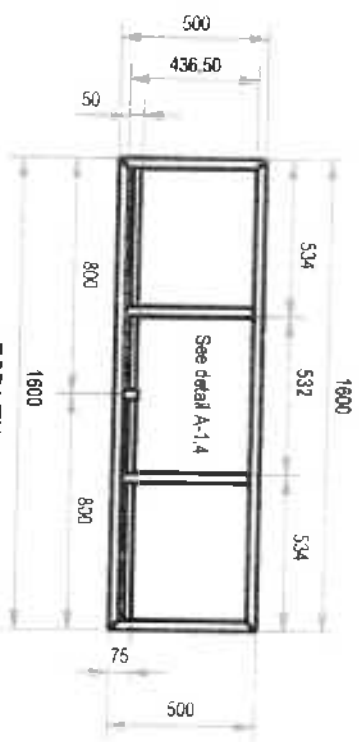

TOP VIEW

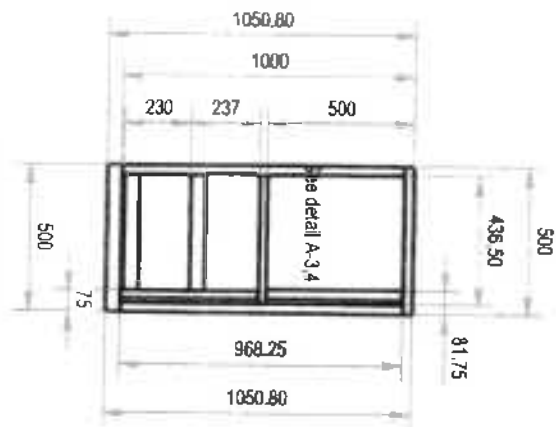

LEFT SIDE VIEW

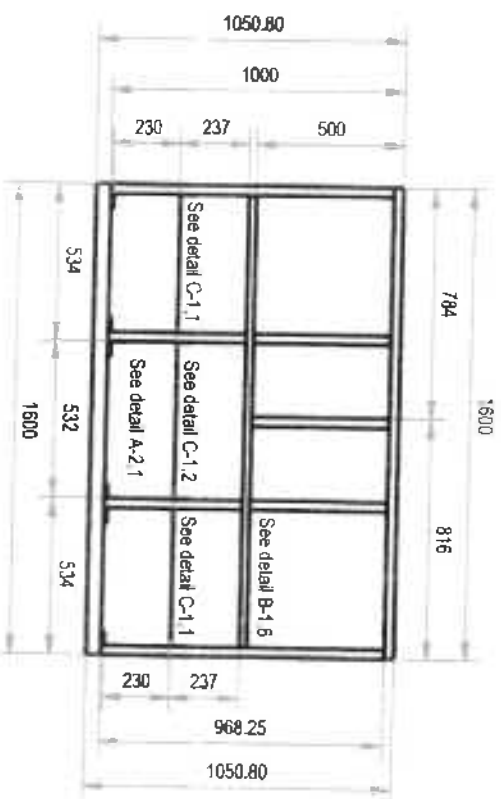

FRONT VIEW

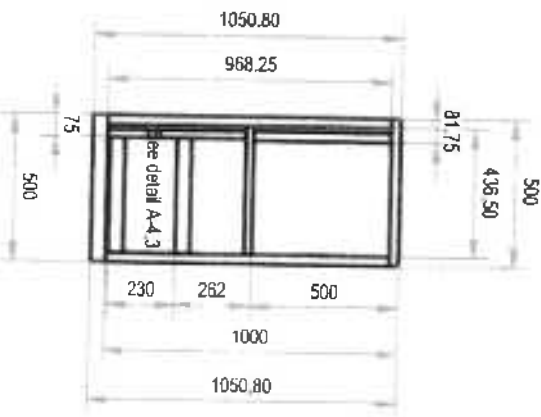

RIGHT SIDE VIEW

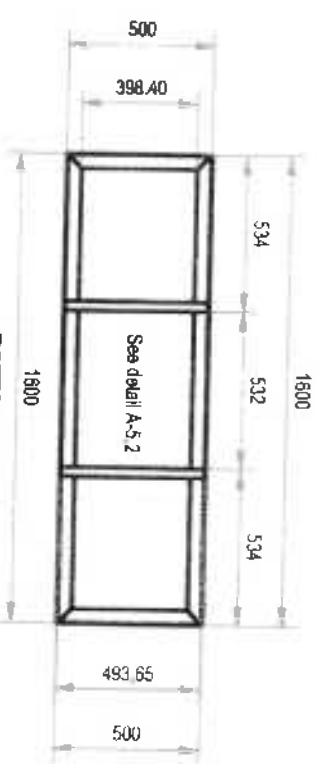

BOTTOM VIEW

MTL BOX NO. 10 FRAME
(SMALL ENGINE REPAIR)
 (The door is not shown in the drawing)

PRODUCED BY AN AUTODESK EDUCATIONAL PRODUCT



TECHNICAL EDUCATION AND SKILLS DEVELOPMENT AUTHORITY

Handwritten mark

PROJECT TITLE
MOBILE TRAINING LABORATORY
 DRAWN BY: JPA
 Scale: 1:25
 Sheet No: 1/1

Handwritten initials

DETAIL A-1.1:

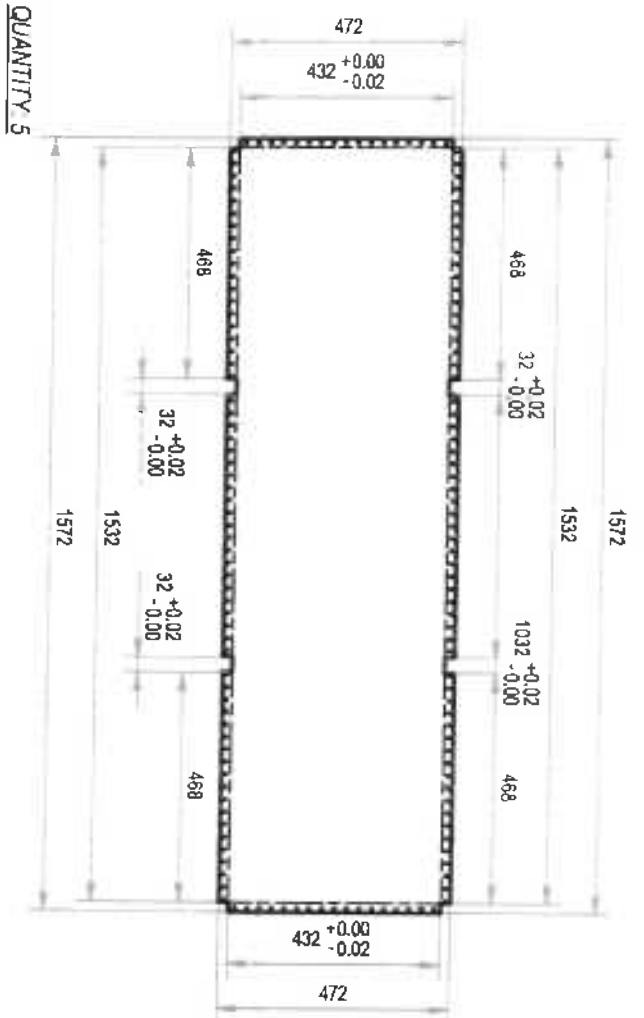

QUANTITY: 5

DETAIL A-1.2:

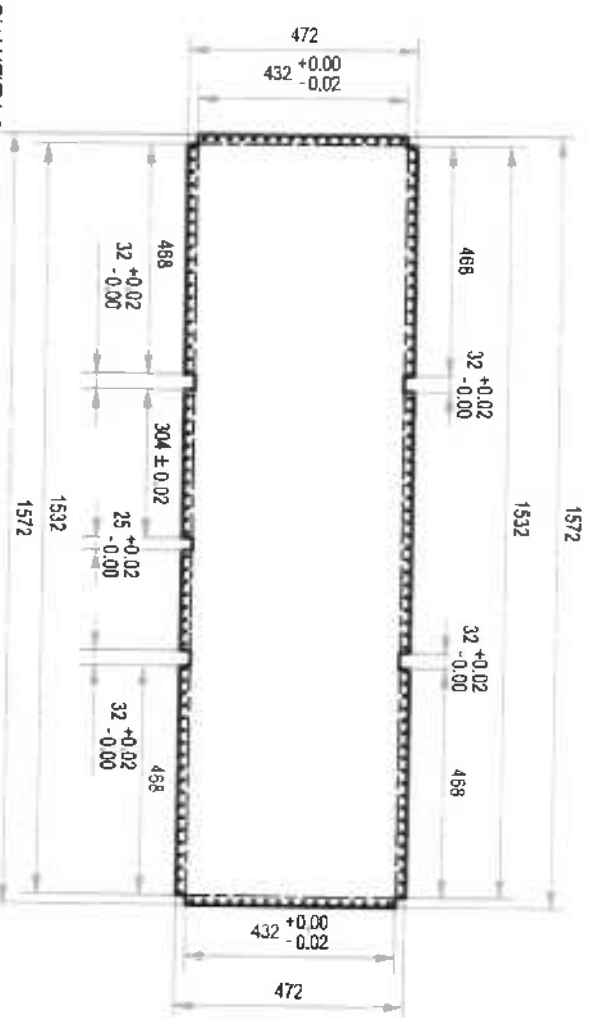

QUANTITY: 2

FLAT PATTERN: GALVANIZED SHEET GAUGE #18, PAINTED

DETAIL A-1.3:

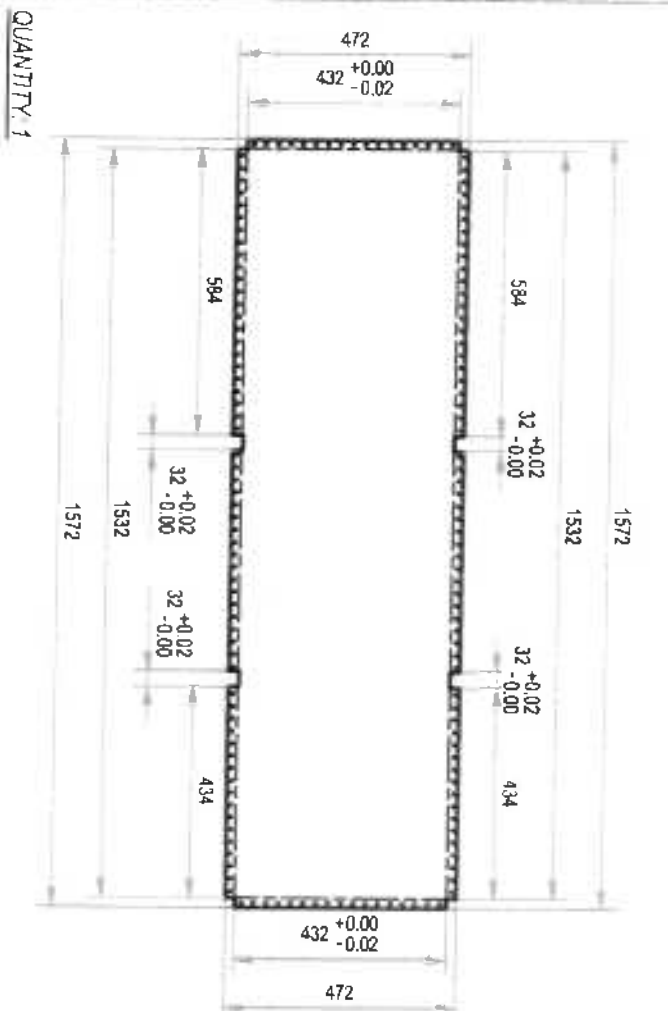

QUANTITY: 1

DETAIL A-1.4:

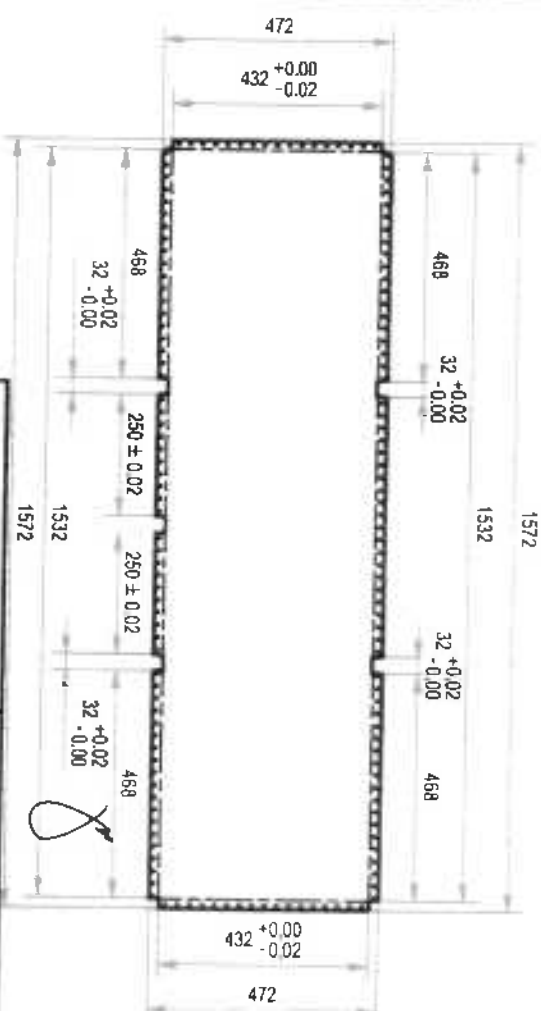

QUANTITY: 2

Use 3/16" blind rivet spaced @ 1" O.C.

PRODUCED BY AN AUTODESK EDUCATIONAL PRODUCT



PROJECT TITLE: MOBILE TRAINING LABORATORY

DATE: 01/15/15

Scale: 1:15

Sheet No: 1/1

Handwritten initials: *aj* and *pd*

DETAIL A-2.2:

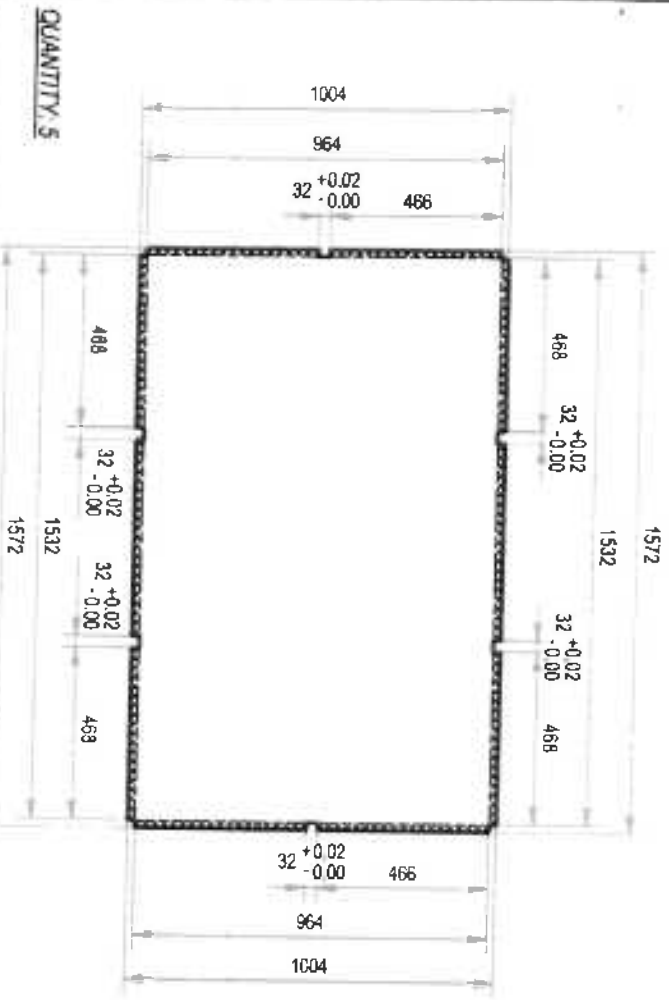

QUANTITY: 5

DETAIL A-2.1:

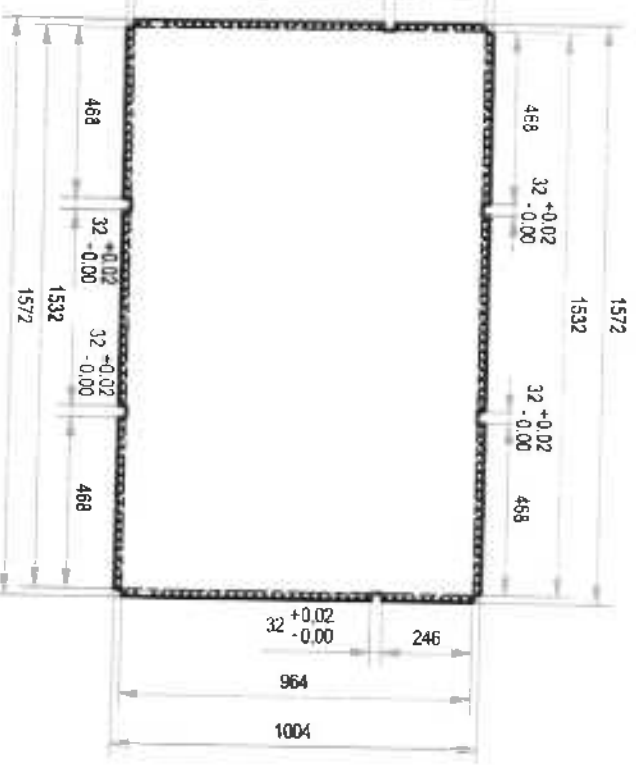

QUANTITY: 2

FLAT PATTERN: GALVANIZED SHEET GAUGE #18, PAINTED

DETAIL A-2.4:

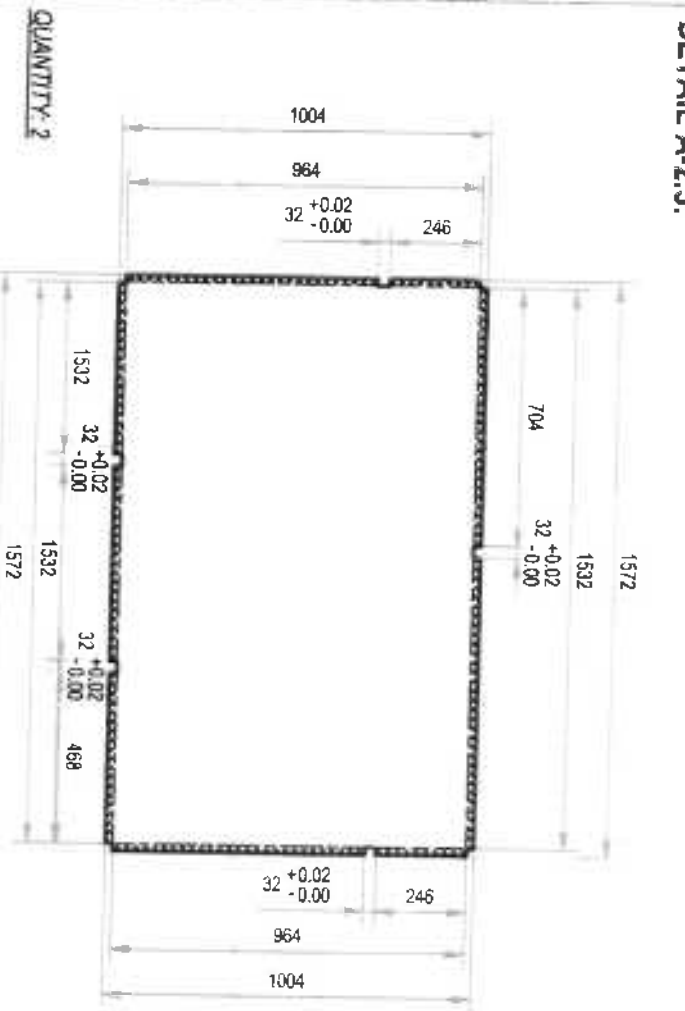

QUANTITY: 2

DETAIL A-2.3:

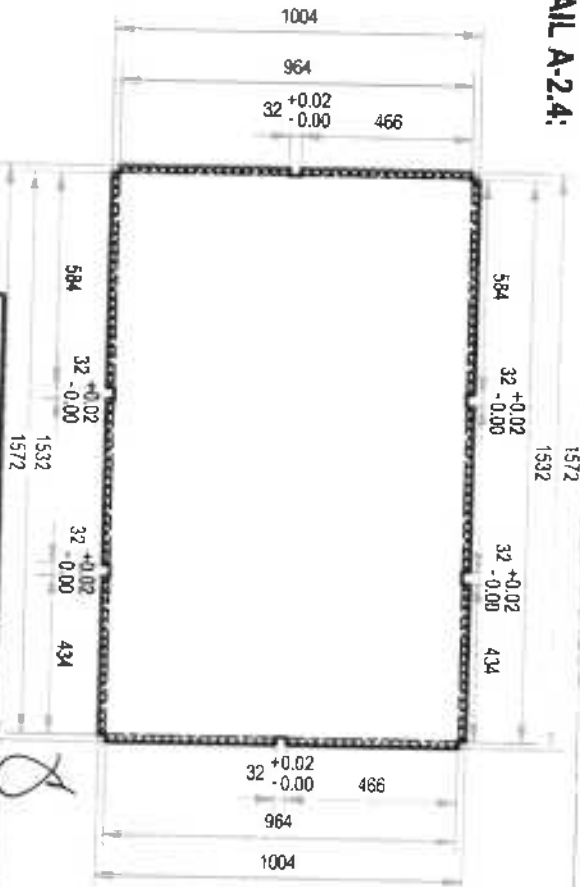

QUANTITY: 1

Use 3/8" blind rivet spaced @ 1" O.C.

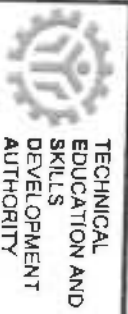

PROJECT TITLE
MOBILE TRAINING LABORATORY

DRAWN BY: JDA
SCALE: 1:20
REVISION NO: 1/

DETAIL A-3.1:

QUANTITY: 5

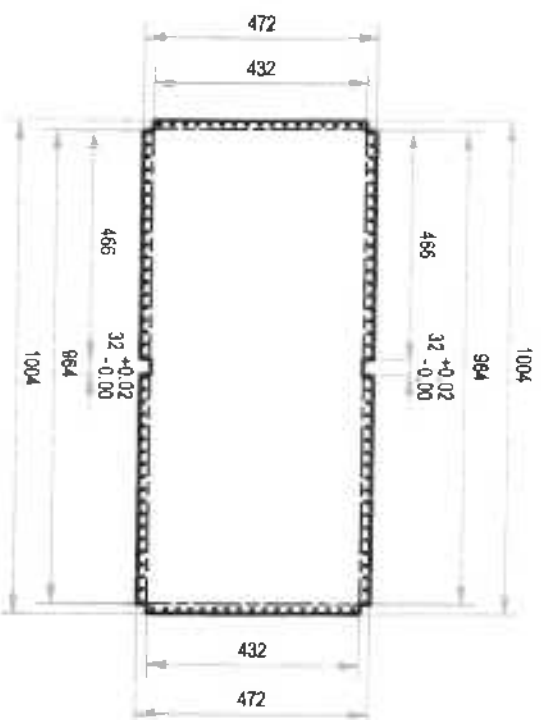

DETAIL A-3.3:

QUANTITY: 1

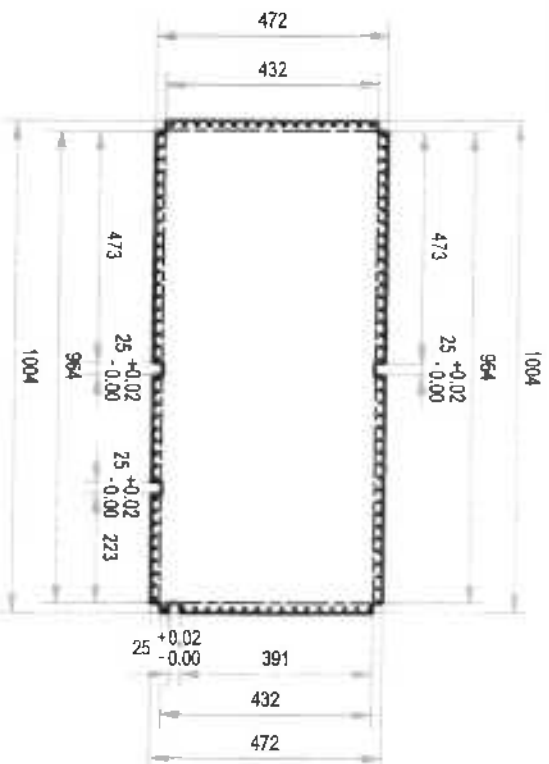

DETAIL A-3.2:

QUANTITY: 4



DETAIL A-3.4:

QUANTITY: 2

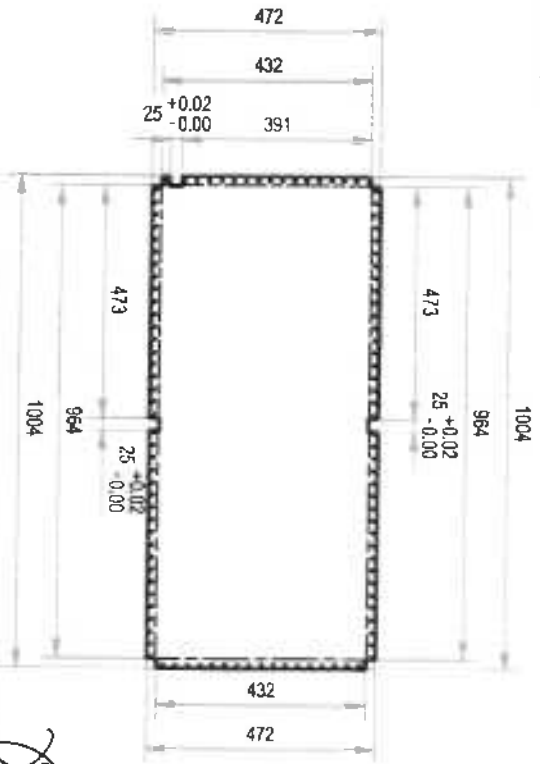

FLAT PATTERN: GALVANIZED SHEET GAUGE #18, PAINTED

PRODUCED BY AN AUTODESK EDUCATIONAL PRODUCT

Use 3/16" blind rivet spaced @ 1" O.C.



PROJECT TITLE
MOBILE TRAINING LABORATORY

Scale: 1:15

DETAIL A-4.1:

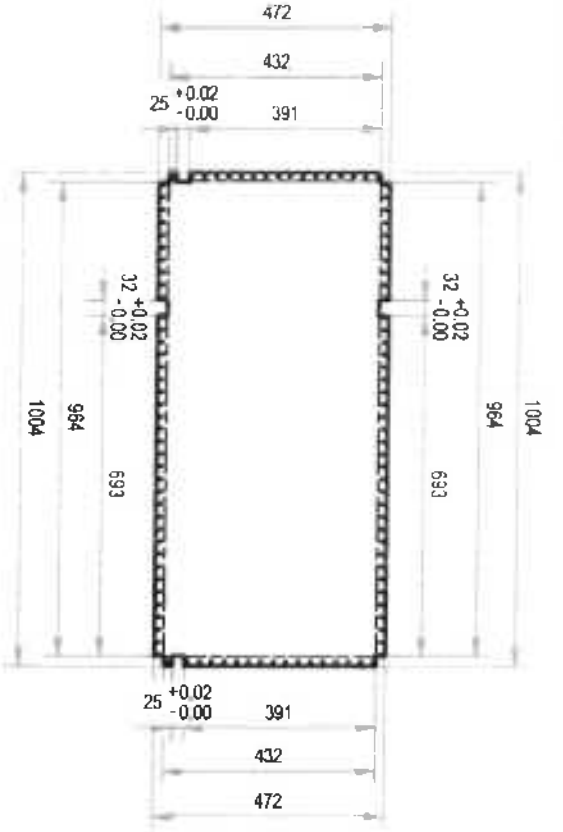

QUANTITY: 4

DETAIL A-4.2:

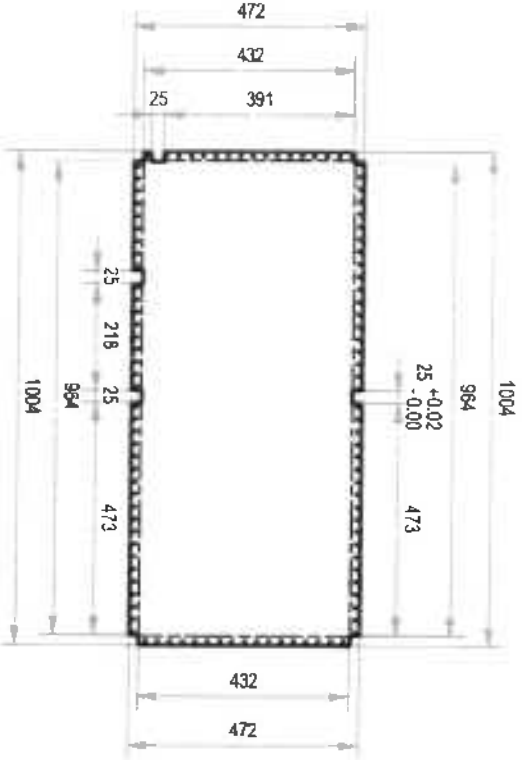

QUANTITY: 2

DETAIL A-4.3:

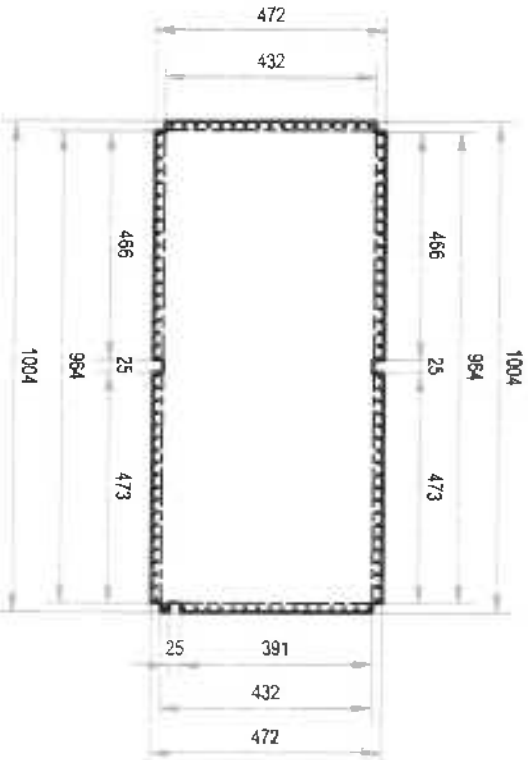

QUANTITY: 2

FLAT PATTERN: GALVANIZED SHEET GAUGE #18, PAINTED

Use 3/16" blind rivet spaced @ 1" O.C.



TECHNICAL EDUCATION AND SKILLS DEVELOPMENT AUTHORITY

PROJECT TITLE
MOBILE TRAINING LABORATORY

DESIGNED BY: JVA
SCALE: 1:15
DRAWN BY: [Signature]

DETAIL A-5.1:

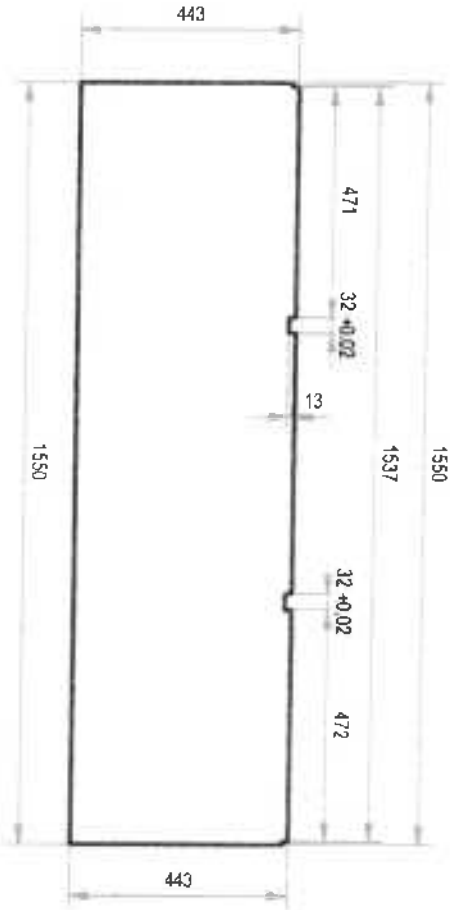

QUANTITY: 1

DETAIL A-5.3:

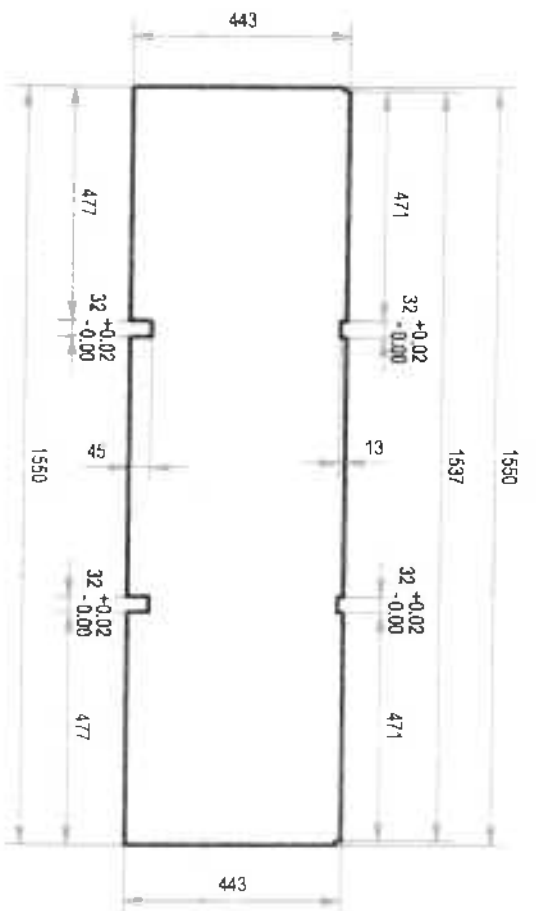

QUANTITY: 2

DETAIL A-5.2:

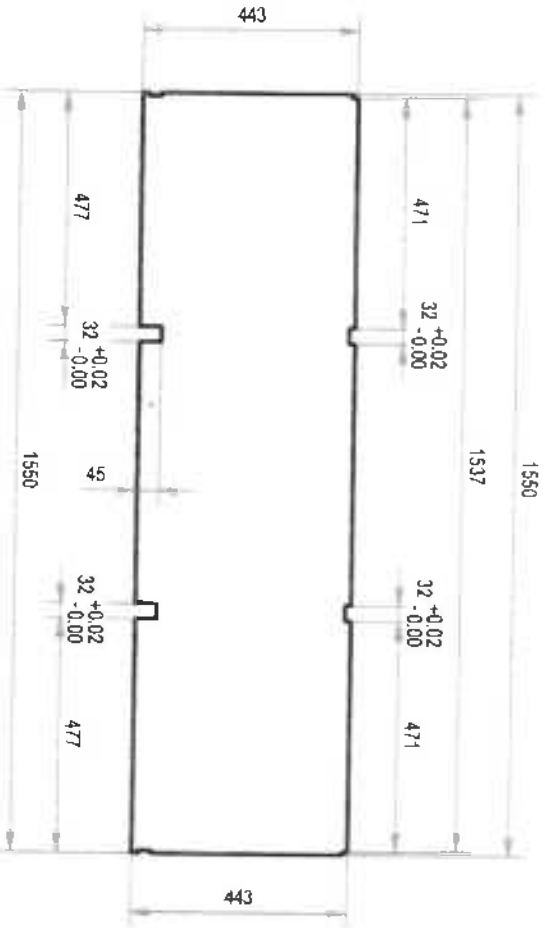

QUANTITY: 6

DETAIL A-5.4:

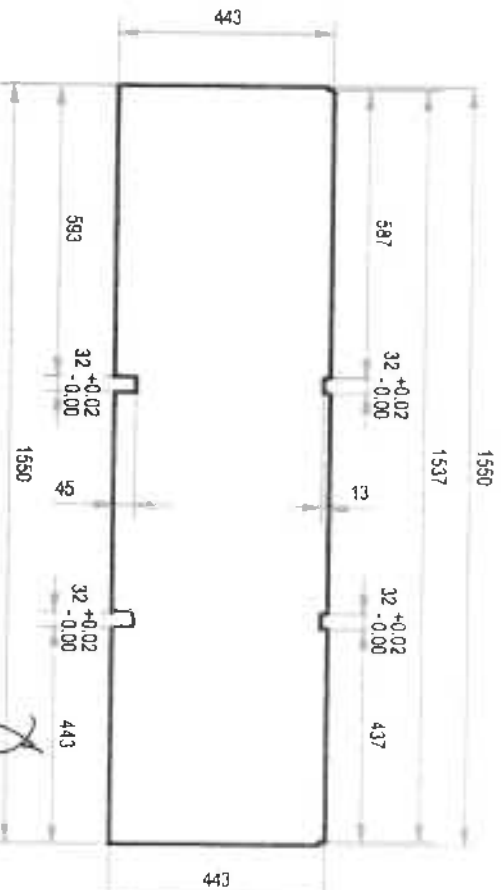

QUANTITY: 1



TECHNICAL EDUCATION AND SKILLS DEVELOPMENT AUTHORITY

PROJECT TITLE
MOBILE TRAINING LABORATORY

DRAWN BY: JVA

Scale: 1:15

Sheet No: 1/1

Handwritten initials 'JVA'

Handwritten initials 'JVA'

DETAIL B-1.5:

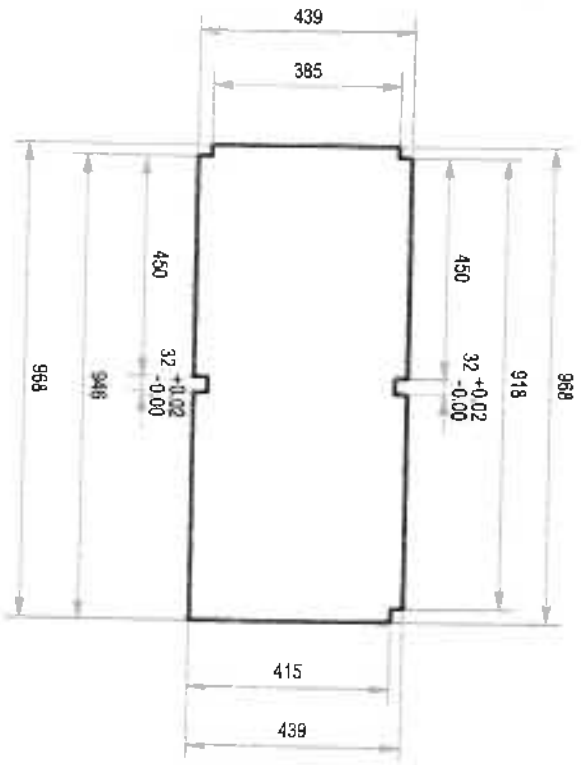

QUANTITY: 1

GALVANIZED SHEET GAUGE #18, PAINTED

DETAIL B-1.6:

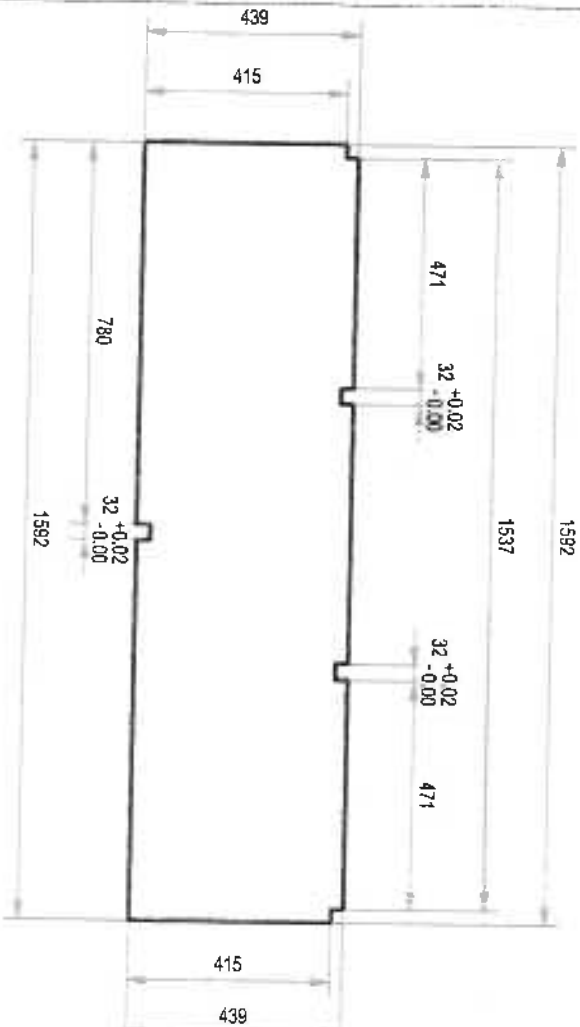

QUANTITY: 2

PRODUCED BY AN AUTODESK EDUCATIONAL PRODUCT



TECHNICAL EDUCATION AND SKILLS DEVELOPMENT AUTHORITY

PROJECT TITLE
MOBILE TRAINING LABORATORY

ENKALIN BR. 204
Scale 1:15

1/

DETAIL C-1.1:

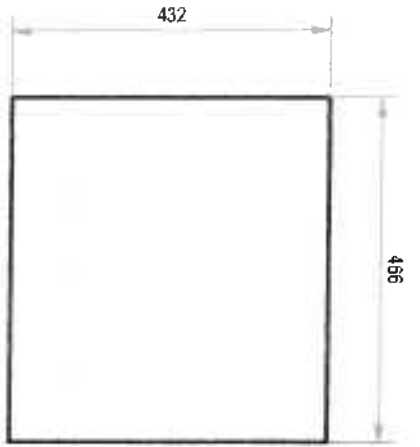

QUANTITY: 15

DETAIL C-1.3:

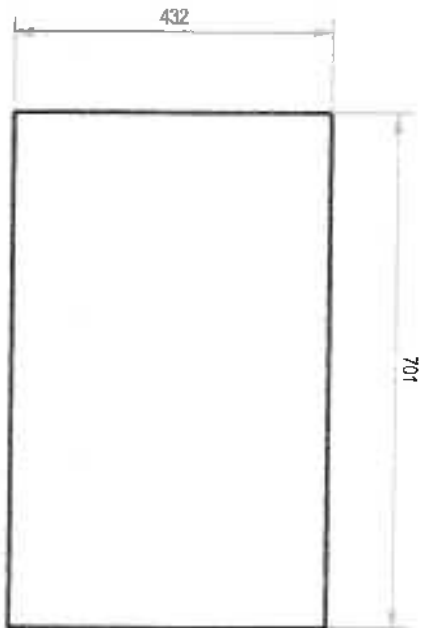

QUANTITY: 2

DETAIL C-1.2:

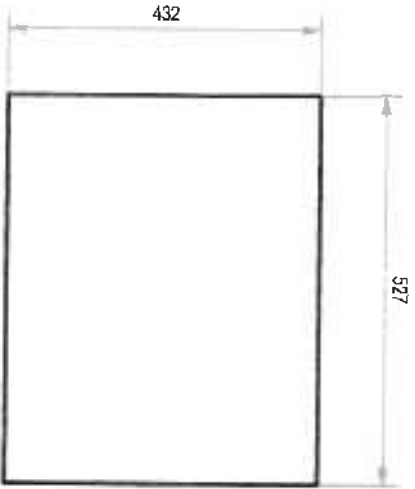

QUANTITY: 9

DETAIL D-1.1:

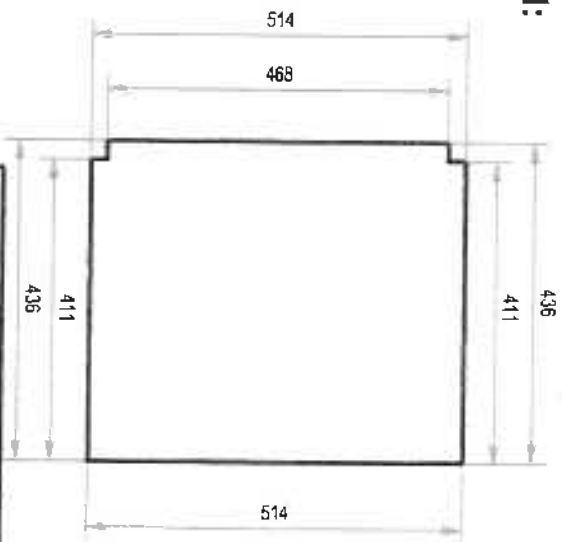

QUANTITY: 1

GALVANIZED SHEET GAUGE #18, PAINTED

PRODUCED BY AN AUTODESK EDUCATIONAL PRODUCT



TECHNICAL EDUCATION AND SKILLS DEVELOPMENT AUTHORITY

PROJECT TITLE
MOBILE TRAINING LABORATORY

DRAWN BY: JDA

SCALE: 1:10

SHEET NO: 1 /



A

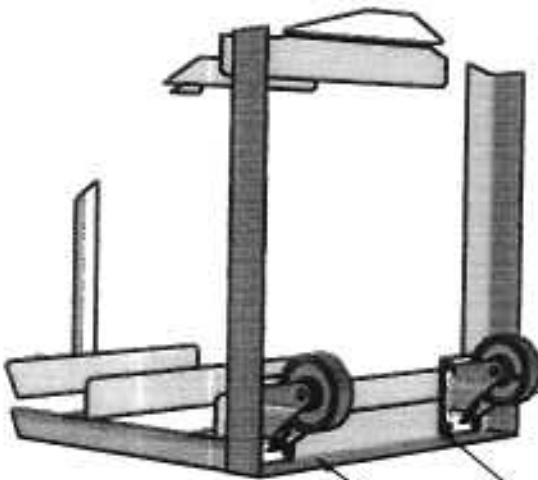

A (1 : 10)

4 pcs. of 4" polyurethane roller wheels with top plate bearing and self-locking; load capacity: 125 lbs. per wheel

Welded in 4" x 4" x 5 mm metal plate

2" x 2" x 3/16" bar, painted



TECHNICAL EDUCATION AND SKILLS DEVELOPMENT AUTHORITY

PROJECT TITLE
MOBILE TRAINING LABORATORY

DRAWN BY: JSA

Scale: 1:20

Sheet No: 11

Handwritten initials and signature

DETAIL F: RUBBER DOOR SEAL

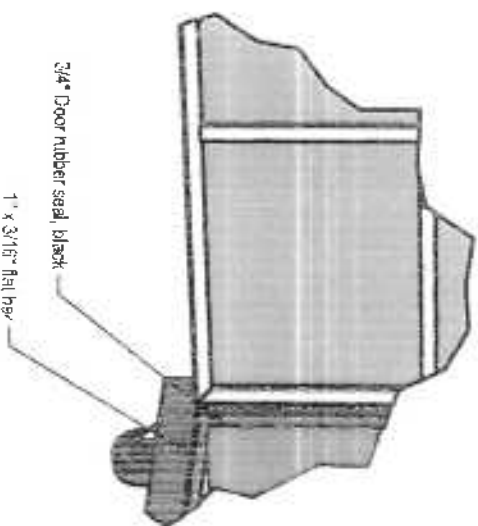
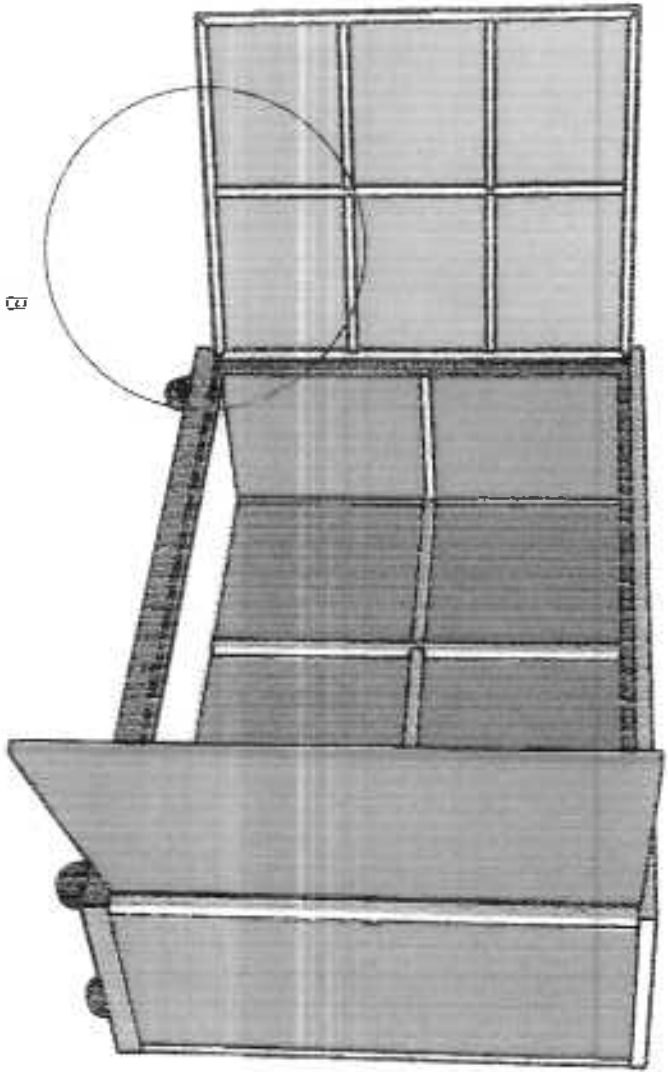

B (1:10)

 TECHNICAL
 EDUCATION AND
 SKILLS
 DEVELOPMENT
 AUTHORITY

PROJECT TITLE
**MOBILE TRAINING
 LABORATORY**

C. 1000 BY JVA
 SHEET 1.25

AH
 1/1
 quid

Handwritten mark

| MTL BOX COVER FRAME, SIDEWAY SWING | | | |
|------------------------------------|------------------------------|-------------|------|
| NO. | MATERIAL | LENGTH, mm | QTY. |
| 1 | Gauge #18 G.I. sheet | 1,009 x 835 | 2 |
| 2 | 1" x 1" x 1.5 mm square tube | 968,25 | 4 |
| 3 | 1" x 1" x 1.5 mm square tube | 928,25 | 2 |
| 4 | 1" x 1" x 1.5 mm square tube | 793,65 | 4 |
| 5 | 1" x 1" x 1.5 mm square tube | 369,825 | 8 |
| 6 | 2" x 2mm piano hinge | 968 | 2 |
| TOTAL | | | 22 |

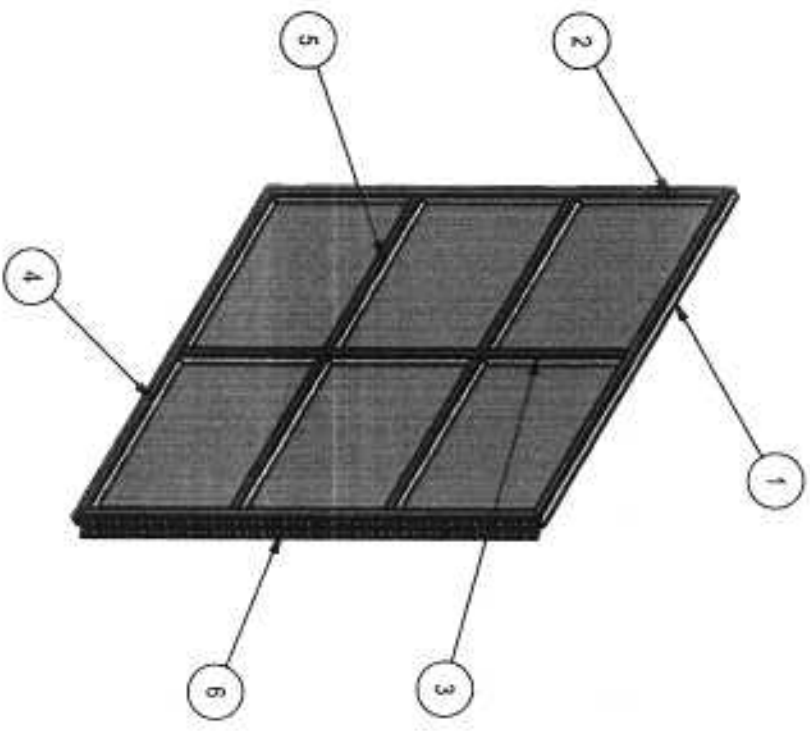

MTL DOOR FRAME



TECHNICAL
EDUCATION AND
SKILLS
DEVELOPMENT
AUTHORITY

PROJECT TITLE
**MOBILE TRAINING
LABORATORY**

DESIGNED BY: *ah* Scale: 1 : 15

DATE: *1 /*

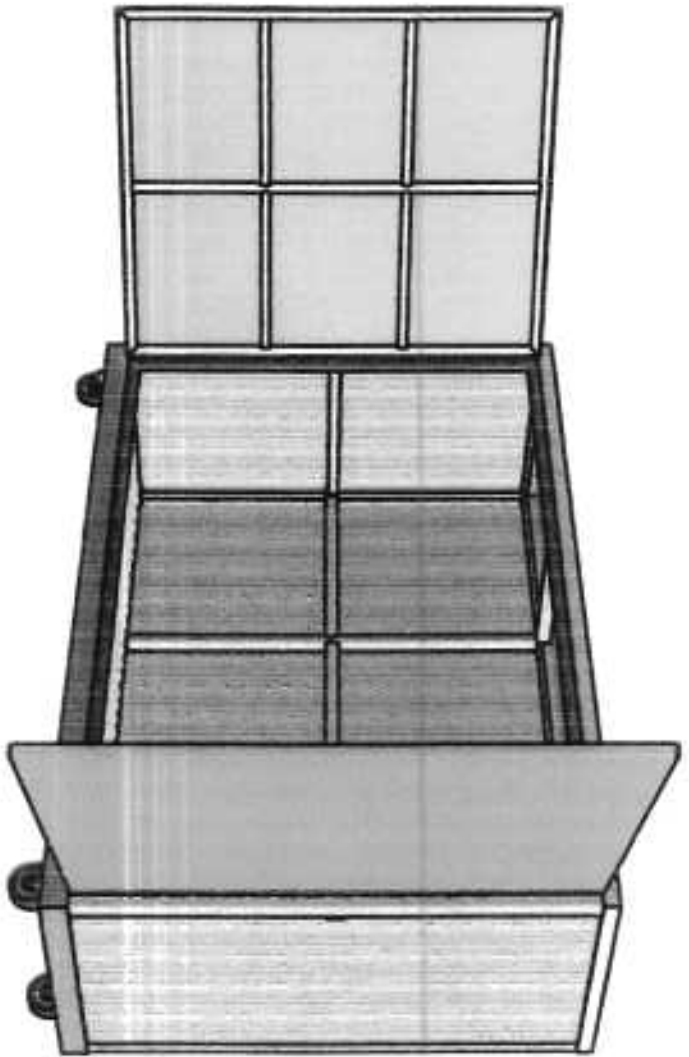

Include 2-sides metal handle
and lock with padlock for the
door (not shown in the drawing)

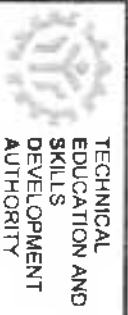

TECHNICAL
EDUCATION AND
SKILLS
DEVELOPMENT
AUTHORITY

PROJECT TITLE

MOBILE TRAINING
LABORATORY

Revision No. / Scale: 1 / 15

Sheet No. 1 /

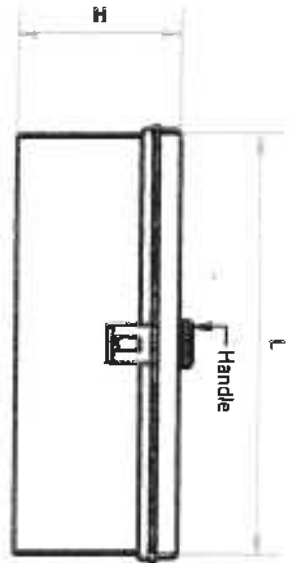

FRONT VIEW

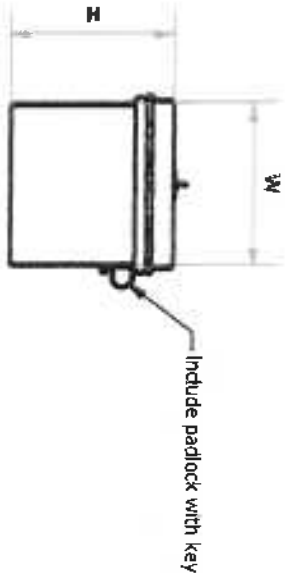

SIDE VIEW

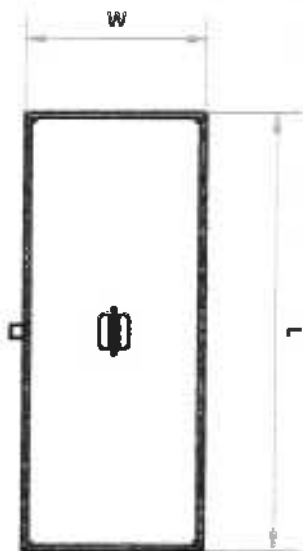

TOP VIEW

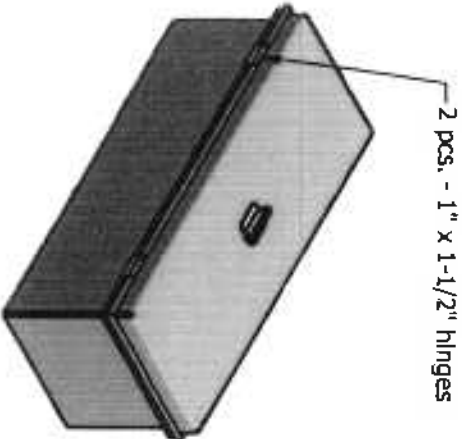

ISOMETRIC VIEW

| TOOLBOX | | | |
|---------|-----------------------|--|---------------------|
| NO. | DIMENSION (L x W x H) | MATERIAL | NO. OF PCS. PER SET |
| 1 | 18" x 7" x 7" | Small Engine Repair - G.A. #18 galvanized sheet, painted | 12 |
| 3 | 18" x 7" x 8" | Appliance Repair - G.A. #18 galvanized sheet, painted | 6 |
| | 18" x 7" x 8" | Electrical Installation and Maintenance - G.A. #18 galvanized sheet, painted | 6 |
| 4 | 20" x 7" x 8" | Small Engine Repair - G.A. #18 galvanized sheet, painted | 6 |
| 5 | 16" x 20" x 4-1/2" | Cookery - Plastic, white | 3 |
| 6 | 16" x 20" x 4-1/2" | Food Processing - Plastic, white | 3 |



TECHNICAL
EDUCATION AND
SKILLS
DEVELOPMENT
AUTHORITY

PROJECT TITLE
COMPACT MOBILE UNIT

Drawn by: JPK
Scale: 1:8
Sheet No: 1/1

Handwritten initials and signature

COMPARATIVE TECHNICAL SPECIFICATION

Lot No. 9 - Appliance Repair Tools and Equipment (for training purposes)

| TESDA'S SPECIFICATIONS | | BIDDER'S SPECIFICATIONS | | |
|------------------------|--|---|------------------|----------------|
| No | Item | Specifications | Item/Brand/Model | Specifications |
| 1 | Soldering Iron | dual wattage, 25 watts/ 120watts, 220 volt 60 Hz, with long life tip, "gun type" | | |
| 2 | Desoldering Tools | desoldering pump with precision regulated return, replacement tip compact, metal housing | | |
| 3 | Screw driver assorted (Phillips and slotted) | 12x7x1 inches, 6 pieces per set, plastic handle | | |
| 4 | Long Nose Plier | dyna grip, 152mm/6" inches carbon steel | | |
| 5 | Diagonal Cutting Plier | dyna grip, 152mm/6" inches carbon steel | | |
| 6 | Nut Drivers | rust-resistant, nickel-plated bar, hexagonal shank, includes: 5mm, 6mm, 7mm, 8mm, 9mm, 10mm, 11mm | | |
| 7 | Wrench, Combination | 6mm, 8mm, 10mm, 11mm, 12mm, 13mm, 14mm, 15mm, 16mm, 17mm, 19m, 21mm, 22mm, 24 mm, chrome vanadium steel | | |
| 8 | Wire Stripper | automatic, cap. 1.5mm to 3.5mm | | |
| 9 | Ballpeen hammer | 12 oz., 11 1/2" overall length forged steel construction, hardened and tempered, wooden handle | | |
| 10 | Flashlight | LED, 3 volts/6 volts, rechargeable | | |

✓
good

COMPARATIVE TECHNICAL SPECIFICATION

| | | | | |
|----|----------------------------|---|--|--|
| 11 | Detector Light | test light, 220 volts | | |
| 12 | Paint Brush | 4 inches width, wooden handle | | |
| 13 | Microwave Oven | power capacity: 220V 1300 watts, interior capacity 20 liters, 8 programmers, defrost option, 26cm diameter rotating turntable, digital | | |
| 14 | Washing Machine with dryer | power capacity: 500w, 220V, rust proof body, gear drive system, dolphin drive pulsator, washing capacity (dry weight) 7.5kg, spinning capacity (dry weight) 5.5kg, width should be more than 50 cm and length of not more than 100 cm | | |
| 15 | Electric Fan | power capacity: 220V, 100w, 60Hz, 3 speed rotary switch, 18 inch metal blade, round/stable plastic base, thermal fuse protection, adjustable height stand fan | | |
| 16 | Electric Rice Cooker | power capacity: 700w, 220V, 60Hz, automatic cooking feature, auto shutoff, glass lid, non-stick coated aluminum pan, includes measuring cup and rice scoop | | |
| 17 | Electric Flat Iron | power capacity: 1000w, 220V, 60 Hz, non-stick Teflon soleplate, thermal fuse protected, variable temperature control, automatic thermostat Control, pilot lamp indicator | | |
| 18 | Coffee Maker | power capacity: 550w, 220V, 60Hz, glass pitcher, anti-drip feature, 6 cup water capacity, water level indicator, swing-out filter basket | | |
| 19 | Oven Toaster | power capacity: 1000w, 220V, 60Hz, stainless steel, 8-liter capacity, 15 minute timer, slide out chrome crumb rack, includes baking tray | | |
| 20 | Blender | 1.5 liter capacity, rated voltage, 230V, 60Hz, power consumption: 300 watts, sharp stainless steel blade, safety lock switch, with plastic | | |

Handwritten signature and initials.

COMPARATIVE TECHNICAL SPECIFICATION

| | | |
|----|--------------|--|
| 21 | Multi Tester | <p>stirrer for easy mixing</p> <p>analog, standard size analog multimeter for measuring voltage, current and resistance. An auxiliary connector is also provided for checking transistors. SPECIFICATION:</p> <ul style="list-style-type: none"> •DC Voltage Range: 0 to 1000V in seven ranges •AC Voltage Range: 0 to 1000V in five ranges •DC Current Range: 0 to 250mA in four ranges •Resistance Range: x1 to 200MEG in four ranges •Transistor hFE Range: -0 to 1000 •Transistors Leakage Current (CEO) Range: -0 to 150mAAF Output Range: -10dB to +22dB |
| 22 | Multi Tester | <p>Digital Multi meters are standard digital multimeter for measuring voltage, current, and resistance with 3-1/2-digit LCD display. This meter measures only 138mm x 70mm x 32mm and weighs approximately 140 grams, including battery.</p> <p>SPECIFICATION:</p> <ul style="list-style-type: none"> •DC Voltage Range: 200mV to 600V in five ranges (auto ranging) •AC Voltage Range: 2V to 600V in four ranges (auto ranging) •DC Current Range: 200mA to 10A in six ranges •Resistance Range: 200 Ohms to 20M in six ranges •Transistor hFE Test Range: 0 to 2000 |
| 23 | Laptop | <p>15.6", Core i7, 1.40GHz, wide screen, 1TB hard drive, 8GB DDR3 memory, NVIDIA GTX 670MX graphic processor, 3GB video memory, Gigabit 10/100/1000Mbps IEEE802.11b/g/n Wireless LAN, web camera, HDMI, Bluetooth, USB2.0, USB3.0, with Windows 8 OS, up to 6 hours charge-in-use battery, DVDRW super Multi with 1 year warranty</p> |

7
 kg pd/m

COMPARATIVE TECHNICAL SPECIFICATION

| | | | | |
|----|----------------|--|--|--|
| 24 | MS Office 2013 | Home & Student 1 user | | |
| 25 | Projector | LCD Projector Portable, RGB liquid crystal shutter projection system (3LCD), White Light Output 2,600 lumens, Colour Light Output 2,600 lumens, XGA Resolution, lightweight: less than 2 kgs. | | |
| 26 | HDMI cable | 3 meters, v1 4A HDMI cable for Projector | | |
| 27 | Whiteboard | wooden whiteboard (2' x 3') with frame, 1 meter collapsible high stand | | |
| 28 | PA System | 550W Portable with Trolley, with 2 wireless mics, 220V, RCA port, with warranty | | |
| 29 | Megaphone | with speak and music switch and volume control, 25w | | |
| 30 | First Aid Kit | First Aid Kit with the contents: betadine, alcohol, adhesive strips, band-aid, disposable gloves, hypoallergenic medical tape (1.25 cm x 9.1m), conforming bandage (5cm), triangular bandage (110m x 110cm), wound dressing no. 15, swab antiseptic, tweezers metal 8 cm, scissors disposable, safety pins assorted (12 pcs), hot and cold compress pack, first aid quick reference guide. | | |

Name of Bidder: _____

Name and Signature of Authorized Representative: _____
 Position/Designation: _____
 Date: _____

1
pd/m
08

COMPARATIVE TECHNICAL SPECIFICATION

Lot No. 10 - Bread and Pastry Tools and Equipment (for training purposes)

| TESDA'S SPECIFICATIONS | | BIDDER'S SPECIFICATIONS | |
|------------------------|-----------------------|---|------------------------------------|
| No. | Item | Specifications | Item/Brand/Model Specifications |
| 1 | Measuring Cup, dry | stainless steel, 4 pcs/set (1c , 1/2c, 1/3c & 1/4c) | |
| 2 | Measuring Cup, liquid | glass graduated, 250 ml capacity | |
| 3 | Measuring Spoon | Stainless steel 6 pcs/set (1/8 tsp, 1/4 tsp, 1/2tsp, 1 tsp 1/2 tbsp, 1 tbsp) | |
| 4 | Cake Turn Table | plastic cake turntable with locking switch, rubberized feet, white, 12.6x12.6x3.54 inches (LxWxH) | |
| 5 | Decorating Tips | stainless steel, 24-piece cake decorating tip set, package size: 17cm x 12cm x 5cm (6.69 x 4.72 x 1.97inches) | |
| 6 | Rolling Pin | wooden, size 33.5 x 5cm, light weight comfortable grip | |
| 7 | Pie Plate, size 6" | aluminum pie pan, 6" diameter x 5/8 in deep, heavy weight round pan | |
| 8 | Pie Plate, size 8" | pie pan, 8" aluminum deep dish pie pan, standard weight aluminum, 8" top outside diameter | |
| 9 | Pie Plate, size 10" | deep aluminum pie pan, 10" diameter, depth 1-1/4", made of 0.7mm thick satin finished aluminum | |

1
2/1/20

COMPARATIVE TECHNICAL SPECIFICATION

| | | | | |
|----|----------------------|---|--|--|
| 10 | Jelly Roll Pan | aluminum, dimension: 2" x 13 x 8' (HXWXD) | | |
| 11 | Cake Spring Form Pan | heavy aluminum spring form pan, heavy duty frame, spring form sides for easy removal, size 9 x 3" | | |
| 12 | Pie Cutter | triple riveted pizza cutter, made of stainless steel, rolling wheel slicer, 6" | | |
| 13 | Rubber Scraper | rubber head, high heat resistant, flexible, 12", color white | | |
| 14 | Spatula | Stainless steel straight blade, 14 inches long with wood handle | | |
| 15 | Cake Stand with tier | 3 tier cake round acrylic cake stand, 3 plates clear, size: 15cm, 20cm, 25cm, 10 inches gap between each tier | | |
| 16 | Saucepan | Stainless steel with cover and handle 26cm | | |
| 17 | Ladle | stainless steel, 12 inches, comes with brush finished handle, hole in the handle for easy hanging | | |
| 18 | Chef Knife | 8 inch, stainless steel full tang blade with plastic handle | | |
| 19 | Chopping Board | 12 x 17 inches, polyethylene, easy grip handle, white color | | |
| 20 | Weighing Scale | manual, maximum weight capacity 2kg, graduated by grams, removable and washable | | |

1 NW
 pd/ ag

COMPARATIVE TECHNICAL SPECIFICATION

| | | | | |
|----|----------------|---|--|--|
| | | tray | | |
| 21 | Grater | made of nonreactive stainless steel easy grip handle | | |
| 22 | Wooden Spoon | wooden turner, size 12 inches | | |
| 23 | Piping Bag | 12 inches, light weight, reusable, flexible polyester, coated can be boiled, dishwasher safe | | |
| 24 | Mixing Bowl | 12 inches' diameter ,8-9 quarts' capacity, stainless | | |
| 25 | Wire Whisk | 8"/20cm, aluminum, balloon style | | |
| 26 | Electric Mixer | 4 qt stainless steel bowl, 5 speeds & quick burst button, bowl rest TM mixer stabilizer, doubles as a hand mixer, 220V, 290-watts peak power, versatile attachment set includes traditional beaters, whisk and dough hooks, brushed stainless steel | | |
| 27 | Dough Cutter | dough scraper 6" wide x 4", high polished stainless steel blade | | |
| 28 | Oven (gas) | stainless door, 2 trays oven with tempered glass window,22-25" collapsible stand | | |
| 29 | Pastry Brush | pastry/basting brush, natural wood handle brushes, 1.5" size | | |

12/28

COMPARATIVE TECHNICAL SPECIFICATION

| | | | | |
|----|---------------------|--|--|--|
| 30 | Bread Knife | 8", serrated edge stain free high -carbon steel blade texture red polypropylene handle | | |
| 31 | Flour Sifter | stainless steel mesh flour sifter strainer .12" | | |
| 32 | Baking Sheet | aluminum ,13" x 18" | | |
| 33 | Muffin Pans | 12 holes, 3 oz. capacity per holes, aluminum | | |
| 34 | Working Table | high quality stainless steel foldable tables dimension: 3ft x 3ft | | |
| 35 | Gas Stove with tank | 2 burner, made from stainless top body, automatic ignition, with complete accessories | | |
| 36 | Kitchen Sink | Kitchen sink, portable single bowl sink stainless steel, with steel collapsible frame legs, with drain hose, Dimension 50cmx50cmx30cm | | |
| 37 | Weighing Scale | digital, 1000g, maximum weight capacity, battery operated (AAA battery) 0.1 g to 1000g, LCD display battery included. | | |
| 38 | Laptop | 15.6", Core i7, 1.40GHz, wide screen, 1TB hard drive, 8GB DDR3 memory, NVIDIA GTX 670MX graphic processor, 3GB video memory, Gigabit 10/100/1000Mbps IEEE802.11b/g/n Wireless LAN, web camera, HDMI, Bluetooth, USB2.0, USB3.0, with Windows 8 OS, up to 6 hours charge-in-use battery, DVDRW super Multi with 1 year warranty | | |

1/21/25

COMPARATIVE TECHNICAL SPECIFICATION

| | | | | |
|----|----------------|--|--|--|
| 39 | MS Office 2013 | Home & Student 1 user | | |
| 40 | Projector | LCD Projector Portable, RGB liquid crystal shutter projection system (3LCD), White Light Output 2,600 lumens, Colour Light Output 2,600 lumens, XGA Resolution, lightweight: less than 2 kgs. 3 meters, v1.4A HDMI cable for Projector | | |
| 41 | HDMI cable | 3 meters, v1.4A HDMI cable for Projector | | |
| 42 | Whiteboard | wooden whiteboard (2' x 3') with frame, 1 meter collapsible high stand | | |
| 43 | PA System | 550W Portable with Trolley, with 2 wireless mics, 220V, RCA port, with warranty | | |
| 44 | Megaphone | with speak and music switch and volume control, 25w | | |
| 45 | First Aid Kit | First Aid Kit with the contents: betadine, alcohol, adhesive strips, band-aid, disposable gloves, hypoallergenic medical tape (1.25 cm x 9.1m), conforming bandage (5cm), triangular bandage (110m x 110cm), wound dressing no. 15, swab antiseptic, tweezers metal 8 cm, scissors disposable, safety pins assorted (12 pcs), hot and cold compress pack, first aid quick reference guide. | | |

Name of Bidder: _____

Name and Signature of Authorized Representative: _____
 Position/Designation: _____

Handwritten initials and signature

COMPARATIVE TECHNICAL SPECIFICATION

Date: _____

Lot No. 11 - Cookery Tools and Equipment (for training purposes)

| TESDA'S SPECIFICATIONS | | BIDDER'S SPECIFICATIONS | |
|------------------------|-----------------|--|------------------|
| No. | Item | Specifications | Item/Brand/Model |
| 1 | Chef Knife | 8 inch, stainless steel full tang blade with plastic handle | |
| 2 | Boning Knife | 6 inches, stainless steel with sharp cutting edge with plastic handle | |
| 3 | Oyster Knife | 7 inches' length (3 inches blade and 4 inches handle), stainless steel blade, with comfortable plastic handle | |
| 4 | Cleaver Knife | 7 inches, stain resistant carbon steel blade | |
| 5 | Tenderizer | with flat and textured side, non slip, 10 inches 25.5 cm, solid aluminum construction | |
| 6 | Skimmer | fine, extra fine mesh, 6 inches diameter, with stainless handle | |
| 7 | Wire Skimmer | small, nickel plated wire oil skimmer, 16 inches long overall, 5 inches diameter bowl | |
| 8 | Skimmer | spider, 5 inches diameter, natural bamboo handle, constructed of durable stainless steel with versatile woven design | |
| 9 | Strainer, small | fine, 6" diameter, with stainless handle | |

1
m 9/10/08

COMPARATIVE TECHNICAL SPECIFICATION

| | | | | |
|----|--------------------------|--|--|--|
| 10 | Siever | small 12" diameter, stainless | | |
| 11 | Strainer, medium | medium, fine stainless steel mesh, 9 inches diameter with stainless handle | | |
| 12 | Turner | solid, stainless steel, with handy loop for hanging, 12 inches long | | |
| 13 | Spatula | Stainless steel straight blade, 14 inches long with wood handle | | |
| 14 | Wooden Spatula | large comfortable handle, 12 inches long, wooden | | |
| 15 | Piping Bag | 12 inches, light weight, reusable, flexible polyester, coated, can be boiled, dishwasher safe | | |
| 16 | Pasty Tubes | steel stainless, set of 24 pcs, different/assorted icing nozzles medium size, constructed of 18/8 quality stainless steel, comes in plastic storage box with lid | | |
| 17 | Strainer, chinois medium | medium, 8 inches diameter, stainless steel including handle | | |
| 18 | Strainer, chinois small | small, 5 inches diameter, stainless steel including handle | | |
| 19 | Funnel | general purpose, hard plastic, comes in 4 different sizes (small, medium, large, extra large) | | |
| 20 | Measuring Spoon | Stainless steel 6 pcs/set (1/8 tsp, 1/4 | | |

✓
NW
9/2/08

COMPARATIVE TECHNICAL SPECIFICATION

| | | | | |
|----|-----------------------|---|--|--|
| | | tsp, 1/2tsp, 1 tsp, 1/2 tbsp, 1 tbsp) | | |
| 21 | Food Tong | 12 inches long, stainless steel, and wide shell head with locking | | |
| 22 | Measuring Cup, liquid | glass graduated, 250 ml capacity | | |
| 23 | Ice Cream Scooper | set of three, stainless steel (2 oz, 4 oz and 6 oz) | | |
| 24 | Cheese Cloth | 100% cotton 1 yard | | |
| 25 | Serving Spoon | stainless steel, 9 inches long | | |
| 26 | Pepper and Salt Mill | 2 in 1, wooden, 8" | | |
| 27 | Weighing Scale | analog weighing scale; maximum weight capacity, 5 kg, graduated by grams, removable and washable tray | | |
| 28 | Weighing Scale | digital, 1000g, maximum weight capacity, battery operated (AAA battery) 0.1 g to 1000g, LCD display battery included. | | |
| 29 | Apple Corer | corer head comfortable on slip handle, corer head is stainless steel | | |
| 30 | Wire Whisk | 8"/20cm, aluminum, balloon style | | |
| 31 | Wire Whisk, medium | medium, 10 inches/25 cm, aluminum, balloon style | | |

1 of 96 M

COMPARATIVE TECHNICAL SPECIFICATION

| | | | | |
|----|--------------------|---|--|--|
| 32 | Wire Whisk, large | heavy duty, stainless steel, 14 inches, balloon style | | |
| 33 | Measuring Cup, dry | stainless steel, 4 pcs/set (1c, 1/2c, 1/3c & 1/4c) | | |
| 34 | Chopping Board | 12 x17 inches, polyethylene, easy grip handle, white color | | |
| 35 | Kitchen Scissors | stainless steel blade, size 2 cm x 12 cm x 27 cm, durable and sturdy handle with comfortable grip | | |
| 36 | Soup Ladle | 3 oz capacity, stainless steel, with handle, round bottom | | |
| 37 | Soup Ladle | 6 oz capacity, stainless steel handle, round bottom | | |
| 38 | Soup Ladle | 8 oz capacity, stainless steel handle, round bottom | | |
| 39 | Soup Ladle | 12 oz capacity, stainless handle, round bottom, | | |
| 40 | Mixing Bowl | 12 inches diameter, 8-9 quarts capacity, stainless | | |
| 41 | Kitchen Spoon | solid, stainless steel handle, comfortable non slip handle, round handle 4.5 x2.5 inches | | |

96

COMPARATIVE TECHNICAL SPECIFICATION

| | | | | |
|----|------------------------|---|--|--|
| 42 | Kitchen Spoon | slotted, stainless steel, comfortable non slip handle, round handle 10 x 2.5 inches w/ hole | | |
| 43 | Kitchen Fork | 7.5 cm x 4.5 cm x 37 cm or 10.5 inches, stainless steel, with 2 prongs, round handle | | |
| 44 | Carving Fork | 10.5 inches, stainless steel, with 2 prongs, round handle | | |
| 45 | Pocket Pin Thermometer | analog, temperature range from 0oF to 220 of, dial type | | |
| 46 | Peeler | Straight blade type, dual stainless steel blade, metal handle 5", 2" handle, 3" blade | | |
| 47 | Stockpot | stainless, 17 quarts capacity (22.7 lit), 12 inches diameter (30.5 cm), depth 31 cm, 4 mm thickness | | |
| 48 | Frying pan | pan, large, non stick, 26 cm diameter | | |
| 49 | Colander | medium, stainless steel, 8 quarts capacity, with base | | |
| 50 | Fish Poacher | medium, 18 inches (L) and 6 inches (W), stainless steel, with handle | | |
| 51 | Casserole | small, stainless steel, 20 cm diameter, with cover | | |
| 52 | Casserole | medium, stainless steel, 24 cm diameter with | | |

7
 N
 96
 ds

COMPARATIVE TECHNICAL SPECIFICATION

| | | | | |
|----|-------------------|---|--|--|
| | | cover | | |
| 53 | Double Boiler | medium, made from stainless steel, 2 quarts capacity, with lid cover | | |
| 54 | Paellara | 40 cm diameter, (50 cm with handle), constructed of carbon steel, riveted secure melt handle, safe for all heating surfaces including induction | | |
| 55 | Baking Tray | small, main material is carbon, rectangular, size 14 x 10 inches | | |
| 56 | Utility Tray | hard plastic tray, rectangular 14x18 inches | | |
| 57 | Fire Extinguisher | cylinder type, multipurpose ABC dry chemical, powder aluminum valve coated, rechargeable, 5 lbs capacity, with pressure gauge that allows for immediate pressure status check, with wall hanger, meets requirements for underwriter laboratory (UJ) | | |
| 58 | Blender | 1.5 liter capacity, rated voltage, 230V, 60HZ, power consumption: 300 watts, sharp stainless steel blade, safety lock switch, with plastic stirrer for easy mixing | | |
| 59 | Pressure Cooker | aluminum, 2 mm, 6 quarts capacity, pressured handle, central pressure valve with self locking mechanism | | |

1
 94
 N
 8

COMPARATIVE TECHNICAL SPECIFICATION

| | | | | |
|----|---------------------|--|--|--|
| 60 | Gas Stove with tank | 2 burner, made from stainless top body, automatic ignition, with complete accessories | | |
| 61 | Working Table | high quality stainless steel foldable tables dimension: 3ft x 3ft | | |
| 62 | Kitchen Sink | Kitchen sink, portable single bowl sink stainless steel, with steel collapsible frame legs, with drain hose, Dimension 50cmx50cmx30cm | | |
| 63 | Laptop | 15.6", Core i7, 1.40GHz, wide screen, 1TB hard drive, 8GB DDR3 memory, NVIDIA GTX 670MX graphic processor, 3GB video memory, Gigabit 10/100/1000Mbps IEEE802.11b/g/n Wireless LAN, web camera, HDMI, Bluetooth, USB2.0, USB3.0, with Windows 8 OS, up to 6 hours charge-in-use battery, DVDRW super Multi with 1 year warranty | | |
| 64 | MS Office 2013 | Home & Student 1 user | | |
| 65 | Projector | LCD Projector Portable, RGB liquid crystal shutter projection system (3LCD), White Light Output 2,600 lumens, Colour Light Output 2,600 lumens, XGA Resolution, lightweight: less than 2 kgs. | | |
| 66 | HDMI cable | 3 meters, v1.4A HDMI cable for Projector | | |

22/9/08

COMPARATIVE TECHNICAL SPECIFICATION

| | | | |
|----|---------------|--|--|
| 67 | Whiteboard | wooden whiteboard (2' x 3') with frame, 1 meter collapsible high stand | |
| 68 | PA System | 550W Portable with Trolley, with 2 wireless mics, 220V, RCA port, with warranty | |
| 69 | Megaphone | with speak and music switch and volume control, 25w | |
| 70 | First Aid Kit | First Aid Kit with the contents: betadine, alcohol, adhesive strips, band-aid, disposable gloves, hypoallergenic medical tape (1.25 cm x 9.1m), conforming bandage (5cm), triangular bandage (110m x 110cm), wound dressing no. 15, swab antiseptic, tweezers metal 8 cm, scissors disposable, safety pins assorted (12 pcs), hot and cold compress pack, first aid quick reference guide. | |

Name of Bidder: _____

Name and Signature of Authorized Representative: _____
 Position/Designation: _____
 Date: _____

1
 9/1/18

COMPARATIVE TECHNICAL SPECIFICATION

Lot No. 12 - Electrical Installation and Maintenance Tools and Equipment (for training purposes)

| TESDA'S SPECIFICATIONS | | BIDDER'S SPECIFICATIONS | | |
|------------------------|-----------------------|--|------------------|----------------|
| No. | Item | Specifications | Item/Brand/Model | Specifications |
| 1. | Spirit Level | high impact plastic; magnetic; 3 vials; Length:24" | | |
| 2. | Hacksaw | adjustable hacksaw frame with bi-metal hacksaw blade, 24 TPI, aluminum alloy frame and handle | | |
| 3. | Pipe Cutter | max. capacity 1/8-2" for steel or ductile iron pipes with steel handle | | |
| 4. | Pipe Reamer | 2" capacity, ratchet type with steel handle, 1/8-2" capacity, suitable for use with power drives | | |
| 5. | Pipe Threader | drop head with 3 sets of head and dies, sizes (1/2", 3/4", 1") | | |
| 6. | Pipe Bender | manual, 1/2-3/4 inch bending radius, ductile high strength iron | | |
| 7. | Electricians Plier | overall length 6, knife length: 5/8", material: carbon steel handle finished: plastic dipped | | |
| 8. | Long Nose Plier | dyna grip, 152mm/6" inches carbon steel | | |
| 9. | Phillips Screw Driver | 1x75, PH 2 x 100, PH 2x125 plastic and rubberized handle chrome vanadium, shank 4" | | |
| 10. | Flat Screw Driver | 3x75, 5x100, 6x125 plastic and rubberized handle chrome vanadium shank 4" | | |
| 11. | Wrench, Combination | 6mm, 8mm, 10mm, 11mm, 12mm, 13mm, 14mm, 15mm, 16mm, 17mm, 19mm, 21mm, 22mm, 24 mm, chrome vanadium steel | | |

1
W/
96/
ak

COMPARATIVE TECHNICAL SPECIFICATION

| | | | | |
|-----|-------------------|--|--|--|
| 12. | Wire Stripper | automatic, cap. 1.5mm to 3.5mm | | |
| 13. | Electrician Knife | blade length 3", taper ground cutlery single steel blade, ergonomically designed slip resistant grip | | |
| 14. | Tool Holster | leather, 3 pocket & 4 holes with belt | | |
| 15. | Pull Push Rule | blade length 8 mtrs, blade width 1", high impact ABS case with durable rubber corrosion resistant lru-zero end | | |
| 16. | Claw Hammer | 16 oz., forged steel construction, hardened and tempered steel head, smooth face, wooden handle | | |
| 17. | Heat Gun | 1600 watts, 230v, 60 Hz, 12.5 amp, dual temperature, with different nozzle | | |
| 18. | Power Drill | drilling cap.: 10mm, cap. wood: 20mm, wattage 350w, no load speed: 0-2500rpm, weight 1.1 kg., Rev. - for rotation, 3/8" capacity: 220VAC, 60Hz | | |
| 19. | Multi-Tester | <p>analog, standard-size analog multimeter for measuring voltage, current, and resistance. An auxiliary connector is also provided for checking transistors. Specifications:</p> <ul style="list-style-type: none"> •DC Voltage Range: 0 to 1000V in seven ranges •AC Voltage Range: 0 to 1000V in five ranges •DC Current Range: 0 to 250mA in four ranges •Resistance Range: x1 to 20KW in four ranges •Transistor hFE Range: -0 to 1000 •Transistors Leakage Current (ICEO) Range: -0 to 150mAAF Output Range: -10dB to +22dB | | |

7/22
db 96

COMPARATIVE TECHNICAL SPECIFICATION

| | | | | |
|-----|----------------|---|--|--|
| 20. | Clamp Ammeter | digital max. AC voltage measurement 600V, max. AC current measurement 400Aac, max. DC voltage measurement 600Vdc, max. resistance measurement 400ohms, battery type AAA, clamp meter type, continuity current, frequency, resistance, voltage, display type LCD, jaw capacity, busbars 10x34mm, safety category voltage, 300V, 600V | | |
| 21. | Pipe Vise | capacity 2", material steel, d with swivel base with dual locking nuts, 360 degrees of rotation. | | |
| 22. | Laptop | 15.6", Core i7, 1.40GHz, wide screen, 1TB hard drive, 8GB DDR3 memory, NVIDIA GTX 670MX graphic processor, 3GB video memory, Gigabit 10/100/1000Mbps IEEE802.11b/g/n Wireless LAN, web camera, HDMI, Bluetooth, USB2.0, USB3.0, with Windows 8 OS, up to 6 hours charge-in-use battery, DVDRW super Multi with 1 year warranty | | |
| 23. | MS Office 2013 | Home & Student 1 user | | |
| 24. | Projector | LCD Projector Portable, RGB liquid crystal shutter projection system (3LCD), White Light Output 2,600 lumens, Colour Light Output 2,600 lumens, XGA Resolution, lightweight: less than 2 kgs. | | |
| 25. | HDMI Cable | 3 meters, v1.4A HDMI cable for Projector | | |
| 26. | Whiteboard | wooden whiteboard (2' x 3') with frame, 1 meter collapsible high stand | | |
| 27. | PA System | 550W Portable with Trolley, with 2 wireless mics, 220V, RCA port, with warranty | | |
| 28. | Megaphone | with speak and music switch and volume control, 25w | | |

TMP
adg

COMPARATIVE TECHNICAL SPECIFICATION

| | | | | |
|-----|---------------|---|--|--|
| 29. | First Aid Kit | <p>First Aid Kit with the contents: betadine, alcohol, adhesive strips, band-aid, disposable gloves, hypoallergenic medical tape (1.25 cm x 9.1m), conforming bandage (5cm), triangular bandage (110m x 110cm), wound dressing no. 15, swab antiseptic, tweezers metal 8 cm, scissors disposable, safety pins assorted (12 pcs), hot and cold compress pack, first aid quick reference guide.</p> | | |
|-----|---------------|---|--|--|

Name of Bidder: _____

Name and Signature of Authorized Representative: _____
 Position/Designation: _____
 Date: _____

13

T
 08/12

COMPARATIVE TECHNICAL SPECIFICATION

Lot No. 13 - Food Processing Tools and Equipment (for training purposes)

| TESDA'S SPECIFICATIONS | | BIDDER'S SPECIFICATIONS | |
|------------------------|-----------------------|-------------------------|--|
| No. | Item | Item/Brand/Model | Specifications |
| 1 | Weighing Scale | | Manual weighing scale; maximum weight capacity, 5 kg., graduated by grams, removable and washable tray |
| 2 | Weighing Scale | | digital, 1000g, maximum weight capacity, battery operated (AAA battery) 0.1 g to 1000g, LCD display battery included |
| 3 | Paring Knives | | stainless steel blade, 4 inches |
| 4 | Peeler | | Straight blade type, dual stainless steel blade, metal handle 5", 2" handle, 3" blade |
| 5 | Measuring Spoon | | Stainless steel 6 pcs/set (1/8 tsp, 1/4 tsp, 1/2tsp, 1 tsp 1/2 tbsp, 1 tbsp) |
| 6 | Measuring Cup, dry | | stainless steel, 4 pcs/set (1c, 1/2c, 1/3c & 1/4c) |
| 7 | Measuring Cup, liquid | | glass graduated, 250 ml capacity |
| 8 | Clocks/Timer | | digital, battery operated, with convenient clip, battery included |
| 9 | Mixing Bowl | | 12 inches diameter, 8-9 quarts capacity, stainless |
| 10 | Chopping Board | | 12x17 inches, polyethylene, easy grip handle, white color |

7

COMPARATIVE TECHNICAL SPECIFICATION

| | | | | |
|----|------------------|--|--|--|
| 11 | Dial Thermometer | stainless steel, 12" stem, stainless clip | | |
| 12 | Osterizers | 8 speed with pulse, 500 watts, 220 volts 60 hertz, stainless steel ice crusher blade, 6 cups glass jar capacity, with warranty. | | |
| 13 | Jar Lifter | non slip handle, rubberized 5" full expansion | | |
| 14 | Food Processors | with exact slice system, 2 in one wide mouth feed tube, with high, low, pulse, off operation, adjustable stainless steel slicing disc and ultra tight seal, 220 volts, 60 hertz, 700 watts | | |
| 15 | Wire Baskets | stainless steel, rectangular, with handle, 4" x 17.75" x 14" (HXWXD) | | |
| 16 | Casseroles | stainless steel, with cover, 5 quarts capacity, with long handles | | |
| 17 | Saucepan | stainless steel, with cover and handle, 26 cm | | |
| 18 | Spoon, wooden | wooden turner, size 12 inches | | |
| 19 | Spoon, basting | 12" long, 100% solid wood, strong and durable. | | |
| 20 | Paddle, wooden | solid wood, 24 inches length x 3-1/2 inches width | | |
| 21 | Food Tong | 12 inches long, stainless steel, and wide shell head with locking | | |

1

COMPARATIVE TECHNICAL SPECIFICATION

| | | | | |
|----|-----------------------------|--|--|--|
| 22 | Kitchen Scissors | stainless steel blade, size 2 cm x 12 cm x 27 cm, durable and sturdy handle with comfortable grip | | |
| 23 | Steamer | 6 quarts base pan doubles as a stock pot, aluminum, with cover, 3 layer, 30 cm | | |
| 24 | Fermented Containers (pail) | hard plastic, with 16 liter capacity, with cover | | |
| 25 | Utility Tray | hard plastic tray, rectangular 14x18 inches | | |
| 26 | Colander | medium, stainless steel, 8 quarts capacity, with base | | |
| 27 | Smoke House | Width - 25" Height - 40" Length - 15", 3 Layers of Parliya inside, 1" for Tray above the Charcoal, 2" for the box of Charcoal, Gauge of Stainless - 1.0 Mirror | | |
| 28 | Gas Stove with tank | 2 burner, made from stainless top body, automatic ignition, with complete accessories | | |
| 29 | Polytemperature Sealer | 300mm long, 220 volts, 60 Hz, 400W | | |
| 30 | Pressure Canner | 25 quarts, stainless steel | | |
| 31 | Pressure Cooker | 8 quarts, stainless steel | | |
| 32 | Electric Oven | 220 V, 60 Hz., 1000W, 18 L capacity, with warranty | | |



COMPARATIVE TECHNICAL SPECIFICATION

| | | | | |
|----|----------------|--|--|--|
| 33 | Meat Grinder | (size in cm) 49 x 23 x 29.5, stainless main materials, 220 volts, 60 Hz, 1/2 HP, with warranty | | |
| 34 | Casseroles | stainless steel, 10" diameter, with lid | | |
| 35 | Working Table | high quality stainless steel foldable tables dimension: 3ft x 3ft | | |
| 36 | Chef Knife | 8 inch, stainless steel full tang blade with plastic handle | | |
| 37 | Laptop | 15.6", Core i7, 1.40GHz, wide screen, 1TB hard drive, 8GB DDR3 memory, NVIDIA GTX 670MX graphic processor, 3GB video memory, Gigabit 10/100/1000Mbps IEEE802.11b/g/n Wireless LAN, web camera, HDMI, Bluetooth, USB2.0, USB3.0, with Windows 8 OS, up to 6 hours charge-in-use battery, DVDRW super Multi with 1 year warranty | | |
| 38 | MS Office 2013 | Home & Student 1 user | | |
| 39 | Projector | LCD Projector Portable, RGB liquid crystal shutter projection system (3LCD), White Light Output 2,600 lumens, Colour Light Output 2,600 lumens, XGA Resolution, lightweight: less than 2 kgs. | | |
| 40 | HDMI cable | 3 meters, v1.4A HDMI cable for Projector | | |
| 41 | Whiteboard | wooden whiteboard (2' x 3') with frame, 1 meter collapsible high stand | | |



COMPARATIVE TECHNICAL SPECIFICATION

| | | | |
|----|---------------|--|--|
| 42 | PA System | 550W Portable with Trolley, with 2 wireless mics, 220V, RCA port, with warranty | |
| 43 | Megaphone | with speak and music switch and volume control, 25w | |
| 44 | First Aid Kit | First Aid Kit with the contents: betadine, alcohol, adhesive strips, band-aid, disposable gloves, hypoallergenic medical tape (1.25 cm x 9.1m), conforming bandage (5cm), triangular bandage (110m x 110cm), wound dressing no. 15, swab antiseptic, tweezers metal 8 cm, scissors disposable, safety pins assorted (12 pcs), hot and cold compress pack, first aid quick reference guide. | |

Name of Bidder: _____

Name and Signature of Authorized Representative: _____
 Position/Designation: _____
 Date: _____

1 N
 106
 08

COMPARATIVE TECHNICAL SPECIFICATION

| Lot No. 14 - Plumbing Tools and Equipment (for training purposes) | | TESDA'S SPECIFICATIONS | | BIDDER'S SPECIFICATIONS | |
|---|----------------|--|------------------|-------------------------|--|
| No. | Item | Specifications | Item/Brand/Model | Specifications | |
| 1 | Pipe Wrench | 12" straight, heavy duty, forged alloy steel 12", pipe capacity 2" or 50mm, weight 1.2 kg. cast-iron housing and I-beam handle with full floating forged hook jaw, featuring self cleaning threads with replaceable hook and heel jaws | | | |
| 2 | Pipe Wrench | 14" straight, heavy duty, forged alloy steel 12", pipe capacity 2" or 50mm, weight 1.6 kg. cast-iron housing and I-beam handle with full floating forged hook jaw, featuring self cleaning threads with replaceable hook and heel jaws | | | |
| 3 | Pull Push Rule | blade length 8 mtrs, blade width 1", high impact ABS case with durable rubber corrosion resistant Iru-zero end | | | |
| 4 | Hacksaw | adjustable hacksaw frame with bi-metal hacksaw blade, 24 TPI, aluminum alloy frame and handle | | | |
| 5 | Spirit Level | high impact plastic; magnetic; 3 vials; Length: 24" | | | |
| 6 | Pipe Reamer | 2" capacity, ratchet type with steel handle, 1/8-2" capacity, suitable for use with power drives | | | |

MJ
ok

COMPARATIVE TECHNICAL SPECIFICATION

| | | | | |
|----|-------------------------------|--|--|--|
| 7 | Pipe Cutter | max. capacity 1/8-2" for steel or ductile iron pipes with steel handle | | |
| 8 | Adjustable Wrench | alloy steel, 0 - 2" jaw opening, 10" length | | |
| 9 | Mechanical Plier | mechanical, plastic dipped insulated handle, 6" length, rust-resistant chrome finish, two position adjustable joint pliers | | |
| 10 | Pipe Vise | capacity 2", material steel, d with swivel base with dual locking nuts, 360 degrees of rotation, | | |
| 11 | Pipe Threader | drop head with 3 sets of head and dies, sizes (1/2", 3/4", 1") | | |
| 12 | Portable Tri-stand Chain Vise | 1/8 to 6 in., rear pipe support, rugged tool tray capacity: 1/8" - 6", leg locking: over center tool tray | | |
| 13 | Manual Pressure Test Pump | 6 mpa, 860 psi max. pressure, 12 L. capacity, with brass pump valve | | |
| 14 | Socket Fusion Machine | 20 mm - 32 mm cap, 3/4", 1", 1-1/4" and 1-1/2", 220V, 1600w | | |
| 15 | Ballpeen hammer | 12 oz., 11 1/2" overall length forged steel construction, hardened and tempered, wooden | | |

Handwritten signature

COMPARATIVE TECHNICAL SPECIFICATION

| | | | | |
|----|-------------------------|---|--|--|
| | | handle | | |
| 16 | Angle Grinder | 4" diameter, wheel cap, 220V, 60 Hz, single phase, 11,000 rpm, all-ball bearing design and metal gear | | |
| 17 | Electric Portable Drill | 1/2" bit jaw capacity, 220V, single phase, variable speed (0-550 rpm), heavy duty, 1/2" drill chuck | | |
| 18 | Carpenter Steel Square | high tempered aluminum steel, 2" x 16" x 24", 5-60 and 30-degree angle markings, high tempered aluminum for maximum durability, 1/8-inch graduations for long-term visibility, body: 24 by 2-inches, tongue: 16 by 1-1/2" | | |
| 19 | Claw Hammer | 16 oz., forged steel construction, hardened and tempered steel head, smooth face, wooden handle | | |
| 20 | Paint Brush | 1/2" round trim brush soft bristle, tin-plated ferrules | | |
| 21 | Hand Gloves | 5 finger, poly/cotton blend with a latex coated palm | | |
| 22 | Safety Hard Hat | V-rib, yellow ball-cap style hard hat with 6 point ratchet-type headgear, 2 point chin strap and V rib on top, polyethylene material | | |

1 M
 10/1/08

COMPARATIVE TECHNICAL SPECIFICATION

| | | | | |
|----|---------------------------|---|--|--|
| 23 | Safety Shoes | heavy duty steel toe cap, waterproof, anti static (sizes 40-42) Its anti-static and heat resistant (up to 300 degree C/572 degree F) with TPU SAFETY cell construction steel toe cap | | |
| 24 | Safety Goggles | clear polycarbonate, woven elastic strap (adjustable) | | |
| 25 | Water Meter | multi jet plastic meter, 1/2" NPT, 20 gpm, brass body | | |
| 26 | Water Closet | flush type, ceramic, dimension (LxWxH): 684x430x787 mm, flushing action: siphonic, single/dual flush: single flush, flush Volume: 6L, flushing activation: front lever, rough-in: 305mm, discharge: floor cover | | |
| 27 | Lavatory with Faucet | center hole, with mixing hot and cold faucet, ceramic, wall hung type, wall hung sink, 4-inch center faucet holes, front overflow, self-draining deck area with contoured back and side splash shields | | |
| 28 | Kitchen Sink with Faucet | stainless steel, rust and heat resistant, grade 304, 74 cm x 51.5 cm, 16.2 mm outlet hole | | |
| 29 | Single Point Water Heater | 4.5kw, 220V, 60 Hz, 2 psi min water pressure, 55 psi, 2 L/min minimum water flow, 1/2" BSP | | |
| 30 | Laptop | 15.6", Core i7, 1.40GHz, wide screen, 1TB hard drive, 8GB DDR3 memory, NVIDIA GTX | | |

My
per

COMPARATIVE TECHNICAL SPECIFICATION

| | | | | |
|----|----------------|---|--|--|
| | | 670MX graphic processor, 3GB video memory, Gigabit 10/100/1000Mbps IEEE802.11b/g/n Wireless LAN, web camera, HDMI, Bluetooth, USB2.0, USB3.0, with Windows 8 OS, up to 6 hours charge-in-use battery, DVDRW super Multi with 1 year warranty | | |
| 31 | MS Office 2013 | Home & Student 1 user | | |
| 32 | Projector | LCD Projector Portable, RGB liquid crystal shutter projection system (3LCD), White Light Output 2,600 lumens, Colour Light Output 2,600 lumens, XGA Resolution, lightweight: less than 2 kgs. | | |
| 33 | HDMI cable | 3 meters, v1.4A HDMI cable for Projector | | |
| 34 | Whiteboard | wooden whiteboard (2' x 3') with frame, 1 meter collapsible high stand | | |
| 35 | PA System | 550W Portable with Trolley, with 2 wireless mics, 220V, RCA port, with warranty | | |
| 36 | Megaphone | with speak and music switch and volume control, 25w | | |
| 37 | First Aid Kit | First Aid Kit with the contents: betadine, alcohol, adhesive strips, band-aid, disposable gloves, hypoallergenic medical tape (1.25 cm x 9.1m), conforming bandage (5cm), triangular bandage (110m x 110cm), wound dressing no. 15, swab antiseptic, tweezers metal 8 cm, scissors disposable, safety pins assorted (12 | | |

92/1/08

COMPARATIVE TECHNICAL SPECIFICATION

| | | | |
|--|--|--|--|
| | pcs), hot and cold compress pack, first aid quick reference guide. | | |
|--|--|--|--|

Name of Bidder: _____

Name and Signature of Authorized Representative: _____
Position/Designation: _____
Date: _____

2/7/08

COMPARATIVE TECHNICAL SPECIFICATION

| Lot No. 15 - Small Engine Repair Tools and Equipment (for training purposes) | | TESDA'S SPECIFICATIONS | | BIDDER'S SPECIFICATIONS | |
|--|----------------------------|--|------------------|-------------------------|--|
| No | Item | Specifications | Item/Brand/Model | Specifications | |
| 1 | Impact Drive Tool | 4pcs, 1/2" Impact Driver Set, heavy duty | | | |
| 2 | Multi-Tester | analog, standard-size analog multimeter for measuring voltage, current, and resistance. An auxiliary connector is also provided for checking transistors. Specifications: <ul style="list-style-type: none"> •DC Voltage Range: 0 to 1000V in seven ranges •AC Voltage Range: 0 to 1000V in five ranges •DC Current Range: 0 to 250mA in four ranges •Resistance Range: x1 to 20KW in four ranges •Transistor hFE Range: -0 to 1000 •Transistors Leakage Current (ICEO) Range: -0 to 150MAAF Output Range: -10dB to +22dB | | | |
| 3 | Oiler | metal case, 1/2 liter cap | | | |
| 4 | Steel Brush | wooden handle | | | |
| 5 | Hacksaw | adjustable hacksaw frame with bi-metal hacksaw blade, 24 TPI, aluminum alloy frame and handle | | | |
| 6 | Center Punch | high speed steel, 5x125 mm | | | |
| 7 | Cold Chisel | flat blade, 1" (W), 6" (L), hardened steel | | | |
| 8 | Fly Wheel/Magneto Puller | universal type, six in one fly wheel magneto puller | | | |
| 9 | Oil Seal Remover/Installer | pointed tip, hardened steel w/ straight handle, 3 pcs per set | | | |

96 7 M
 of

COMPARATIVE TECHNICAL SPECIFICATION

| | | | | |
|----|-------------------------|--|--|--|
| 10 | Piston Ring Compressor | self locking w/ L wrench steel, range 2 1/8" to 5 inch diameter | | |
| 11 | Valve Spring Compressor | spring loaded offset jaw overhead valve spring compressor, steel | | |
| 12 | Clutch Assembly Remover | universal compressor clutch hub for removal and installation | | |
| 13 | Electricians Plier | overall length 6, knife length: 5/8", material: carbon steel handle finished: plastic dipped | | |
| 14 | Diagonal Cutting Plier | dyna grip, 152mm/6" inches carbon steel | | |
| 15 | Mechanical Plier | 8", insulated handle | | |
| 16 | Vise Gripped Plier | 10R straight jaw | | |
| 17 | Feeler Gauge | 26 blade feeler gauge set, metric & english marked gauge | | |
| 18 | Screwdriver, Flat | 8", magnetic tip, chrome vanadium, plastic handle | | |
| 19 | Screwdriver, Philips | 8", magnetic tip, chrome vanadium, plastic handle | | |
| 20 | Ballpeen hammer | 12 oz., 11 1/2" overall length forged steel construction, hardened and tempered, wooden handle | | |
| 21 | Hammer, Brass/copper | 1 lb., wooden handle | | |
| 22 | Hammer, Plastic | 1 lb, wooden handle, plastic tip hammer | | |
| 23 | Wrench, Sparkplug | 19x16 mm, hexagonal w/ handle | | |

Handwritten signature/initials

COMPARATIVE TECHNICAL SPECIFICATION

| | | | | |
|----|---------------------|--|--|--|
| 24 | Wrench, Combination | 6mm,8mm,10mm,11mm,12mm,13mm,14mm,15mm,16mm,17mm,19mm, 21mm,22mm, 24 mm, chrome vanadium steel | | |
| 25 | Wrench, Socket | 8 - 32 mm,, black, 1/2" drive | | |
| 26 | Wrench, T-type | 8, 10, 12, 14 mm | | |
| 27 | Hand Tractor Engine | diesel engine, single piston, 4 stroke direct injection, 10-12 hp | | |
| 28 | Laptop | 15.6", Core i7, 1.40GHz, wide screen, 1TB hard drive, 8GB DDR3 memory, NVIDIA GTX 670MX graphic processor, 3GB video memory, Gigabit 10/100/1000Mbps IEEE802.11b/g/n Wireless LAN, web camera, HDMI, Bluetooth, USB2.0, USB3.0, with Windows 8 OS, up to 6 hours charge-in-use battery, DVDRW super Multi with 1 year warranty | | |
| 29 | MS Office 2013 | Home & Student 1 user | | |
| 30 | Projector | LCD Projector Portable, RGB liquid crystal shutter projection system (3LCD), White Light Output 2,600 lumens, Colour Light Output 2,600 lumens, XGA Resolution, lightweight: less than 2 kgs. | | |
| 31 | HDMI cable | 3 meters, v1.4A HDMI cable for Projector | | |
| 32 | Whiteboard | wooden whiteboard (2' x 3') with frame, 1 meter collapsible high stand | | |
| 33 | PA System | 550W Portable with Trolley, with 2 wireless mics, 220V, RCA port, with warranty | | |

906 N
10/1

COMPARATIVE TECHNICAL SPECIFICATION

| | | | | |
|----|---------------|--|--|--|
| 34 | Megaphone | with speak and music switch and volume control, 25w | | |
| 35 | First Aid Kit | First Aid Kit with the contents: betadine, alcohol, adhesive strips, band-aid, disposable gloves, hypoallergenic medical tape (1.25 cm x 9.1m), conforming bandage (5cm), triangular bandage (110m x 110cm), wound dressing no. 15, swab antiseptic, tweezers metal 8 cm, scissors disposable, safety pins assorted (12 pcs), hot and cold compress pack, first aid quick reference guide. | | |

Name of Bidder: _____

Name and Signature of Authorized Representative: _____
 Position/Designation: _____
 Date: _____

OK 7/11

COMPARATIVE TECHNICAL SPECIFICATION

Lot No. 16 - Electrical Installation and Maintenance Mock-up

| No. | TESDA'S SPECIFICATIONS | | BIDDER'S SPECIFICATIONS | |
|-----|---|----------------------|-------------------------|----------------|
| | Item | Specifications | Item/Brand/Model | Specifications |
| 1 | Electrical Installation Maintenance (EIM) Mock-Up | | | |
| 2 | Heat gun | 1200 watts | | |
| 3 | PVC adapter | with lock nuts | | |
| 4 | Circuit breaker, | 30A | | |
| 5 | PVC pipe | 1/2" diameter | | |
| 6 | Cable ties | 100 pcs./pack | | |
| 7 | Incandescent bulb | 220V, 25W | | |
| 8 | One pole switch with plate | flush type | | |
| 9 | Three way switch with plate | flush type | | |
| 10 | Four way switch with plate | flush type | | |
| 11 | Lamp receptacle | 4" X 4" surface type | | |
| 12 | Photo electrical | (photocell) | | |
| 13 | Convenience outlet | universal type | | |
| 14 | Floor outlet | round type | | |
| 15 | Ground fault | current interrupter | | |

MS
7

COMPARATIVE TECHNICAL SPECIFICATION

| | | | | |
|----|-----------------|----------------------------------|--|--|
| 16 | Circuit breaker | 60A with built in housing | | |
| 17 | Terminal block | 15A 12 slots | | |
| 18 | Automotive Wire | #14 AWG (1 solid and 1 stranded) | | |
| 19 | Terminal lug | Y type | | |

Name of Bidder: _____

Name and Signature of Authorized Representative: _____
Position/Designation: _____
Date: _____

M J
MS
MS

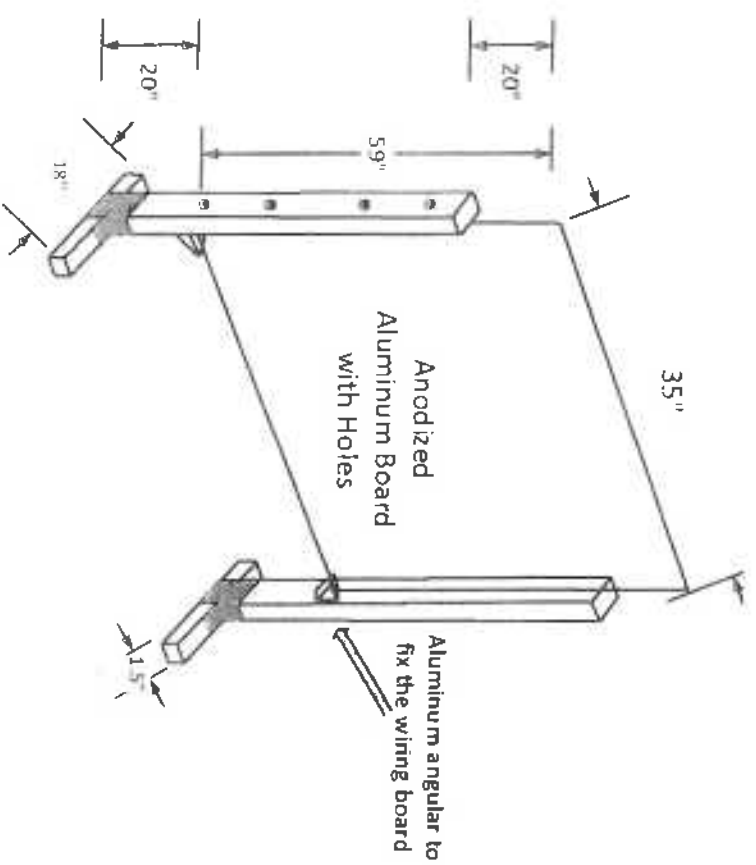

- List of Components:**
- 1 pc - 60 A CIRCUIT BREAKER (CB)
 - 2 pcs - 30 A CIRCUIT BREAKER (CB)
 - 2 pcs - THREE (3)WAY SWITCH
 - 2 pcs - SPST SWITCH
 - 1 pc - GROUND FAULT CURRENT INTERRUPTER (GFCI)
 - 5 pcs - JUNCTION BOX
 - 5 pcs - UTILITY BOX
 - 5 pcs - ONE GANG PLATE COVER
 - 5 pcs - TWO GANG PLATE COVER
 - 5 pcs - LAMP RECEPTACLE
 - 5 pcs - LAMP

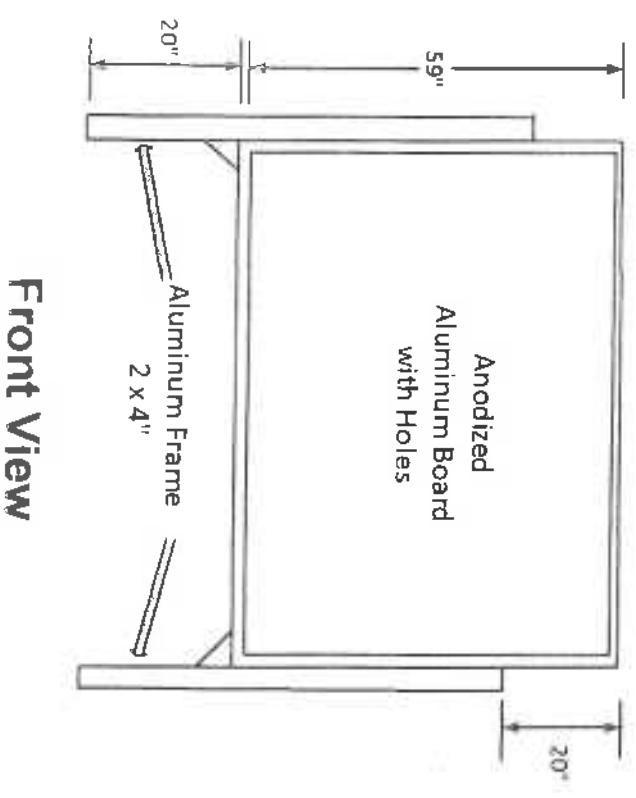

Front View

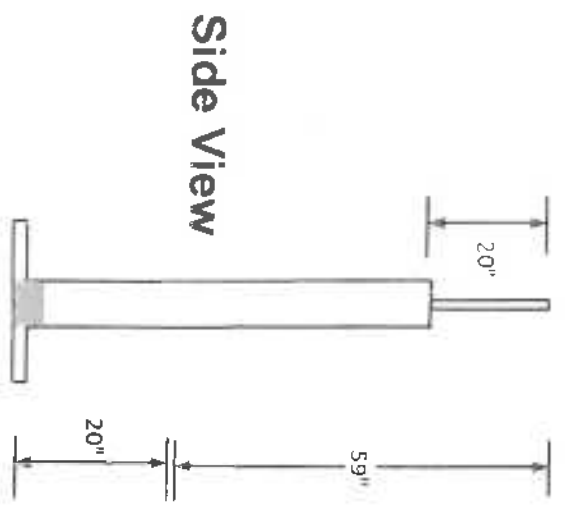

Side View

DETAILS OF MTL CIRCUIT BOARD MOCK UP FOR EIM

Handwritten signature and date: Nw 1/1 08

ANODIZED ALUMINUM BOARD WITH HOLES

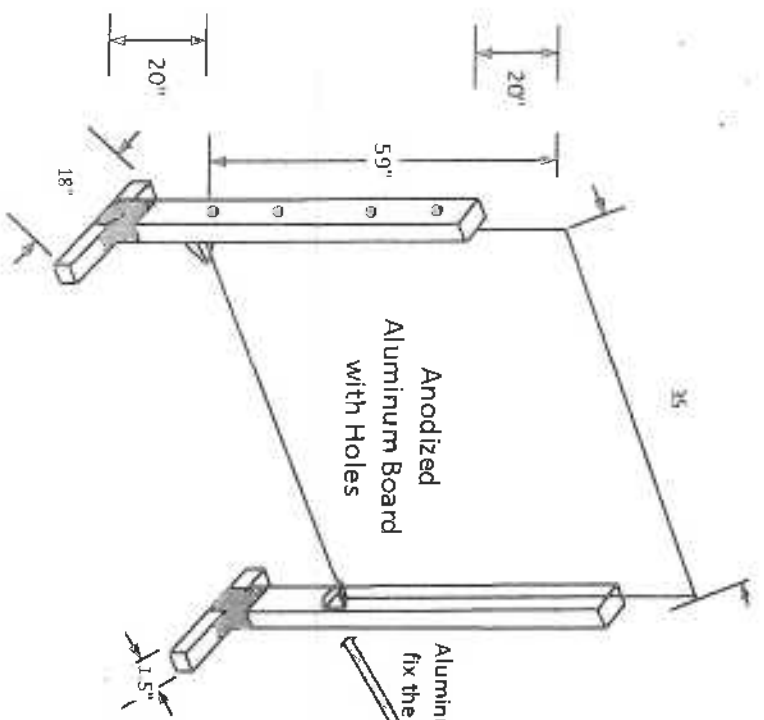

Aluminum angular to fix the wiring board

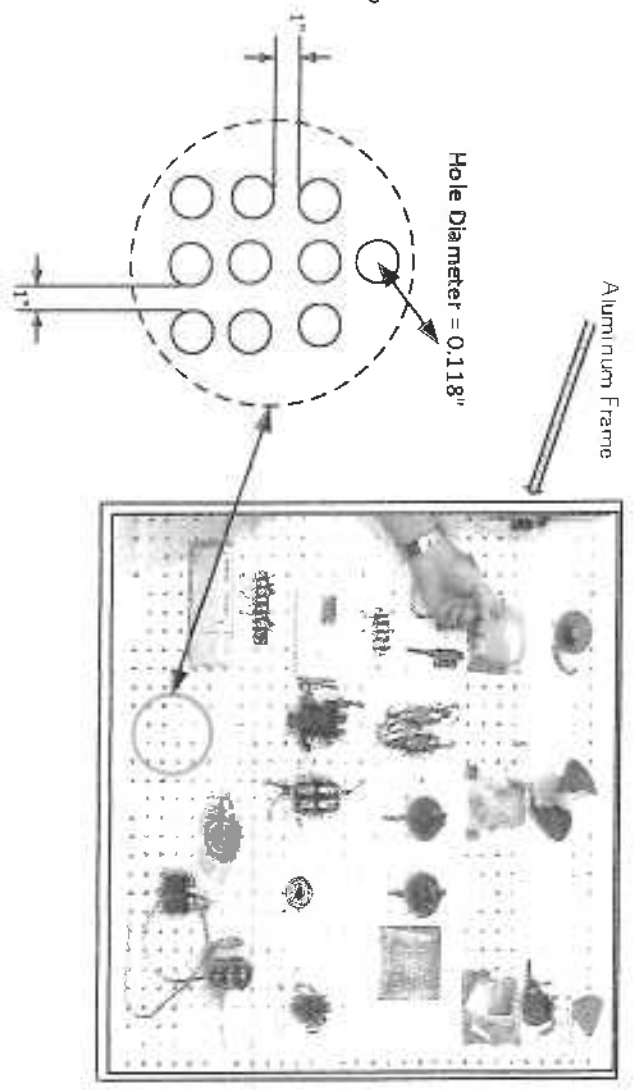

Assemble type w/ screw

SCREWS

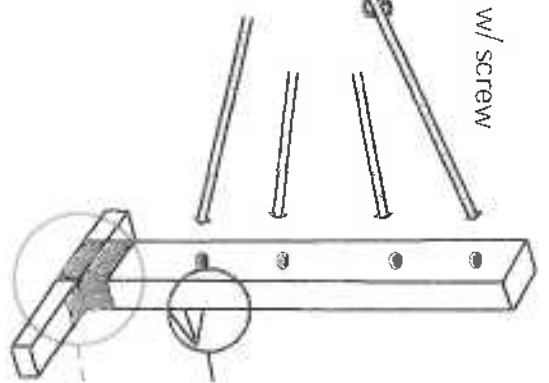

FRONT and BACK SLOB CONNECTOR/ PROTECTOR

CENTER BOARD HOLDER

SCREWS

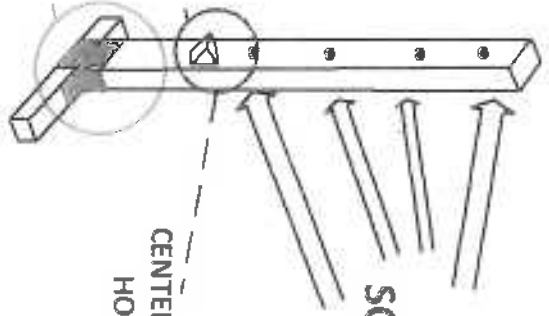

N 7 108

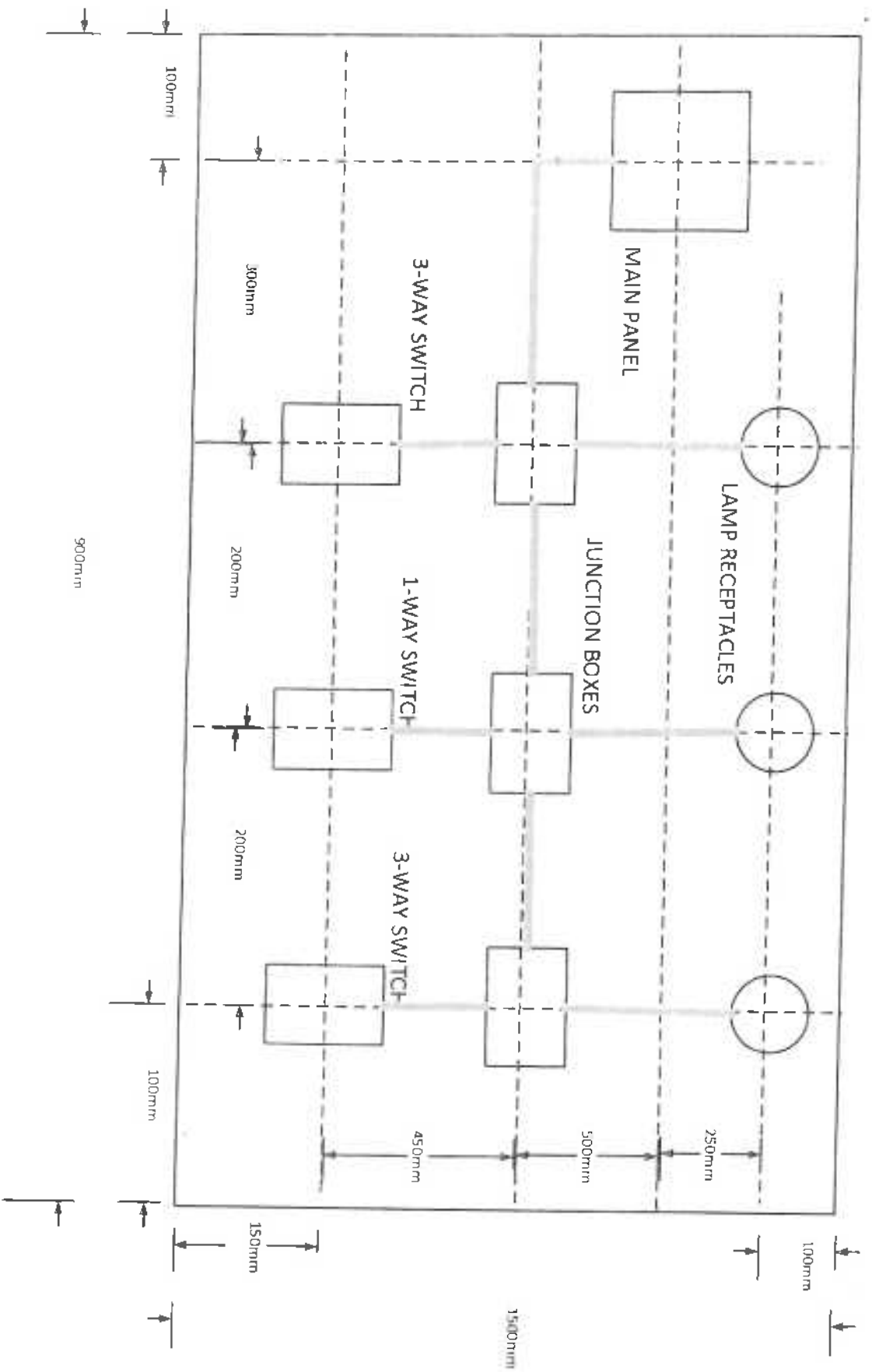

M.P.S

COMPARATIVE TECHNICAL SPECIFICATION

LOT 17 - Plumbing Mock-up

| No. | TESDA'S SPECIFICATIONS | | BIDDER'S SPECIFICATIONS | |
|-----|-------------------------------|-----------------|-------------------------|----------------|
| | Item | Specifications | Item/Brand/Model | Specifications |
| 1. | Plumbing Mock-up (Labor Cost) | | | |
| 2. | PVC Pipe | 4" dia (Orange) | | |
| 3. | PVC Elbow | 4" dia. 90 deg. | | |
| 4. | PVC Elbow | 4" dia. 45 deg. | | |
| 5. | PVC Clean Out | 4" dia. | | |
| 6. | PVC Wye | 4" x 3" | | |
| 7. | PVC Wye | 4" x 2" | | |
| 8. | PVC pipe | 3" dia. | | |
| 9. | PVC Elbow | 3" | | |
| 10. | PVC Elbow | 3" 45 deg. | | |
| 11. | PVC Tee | 3" x 2" | | |
| 12. | PVC Tee | 3" x 3" | | |
| 13. | PVC Pipe | 2" dia | | |
| 14. | PVC Elbow | 2" dia. 45 deg. | | |

7/21

COMPARATIVE TECHNICAL SPECIFICATION

| | | | | |
|-----|---------------------|---|--|--|
| 15. | PVC Elbow | 2" dia. 90 deg. | | |
| 16. | PVC Tee | 2" | | |
| 17. | PVC P-trap | 2" | | |
| 18. | PPr pipe | 1/2" dia. | | |
| 19. | PPr elbow | 1/2" dia. | | |
| 20. | PPr tee | 1/2" dia. | | |
| 21. | PPr elbow connector | 1/2" dia. | | |
| 22. | PPr male connector | 1/2" dia. | | |
| 23. | PPr union | 1/2" dia. | | |
| 24. | PPr coupling | 1/2" dia. | | |
| 25. | Urinal | 480mm X 730mm X 730mm with complete accessories | | |
| 26. | Shower head | with complete accessories | | |
| 27. | flexible hose | 1/2 x 7/8 | | |
| 28. | angle valve | 1/2 x 1/2" | | |
| 29. | Marine Plywood | 3/4" X 4' X 8' | | |

of 4

COMPARATIVE TECHNICAL SPECIFICATION

| | | | | | |
|-----|--------------|----------------------|--|--|--|
| 30. | Lumber | 2" x 2" x 12' | | | |
| 31. | Teflon Tape | | | | |
| 32. | Metal hinges | 2" X 4" , heavy duty | | | |

Name of Bidder: _____

Name and Signature of Authorized Representative: _____
Position/Designation: _____
Date: _____

T John
alg

100% of people

Collapsible
w/ Hinges

100%

100%

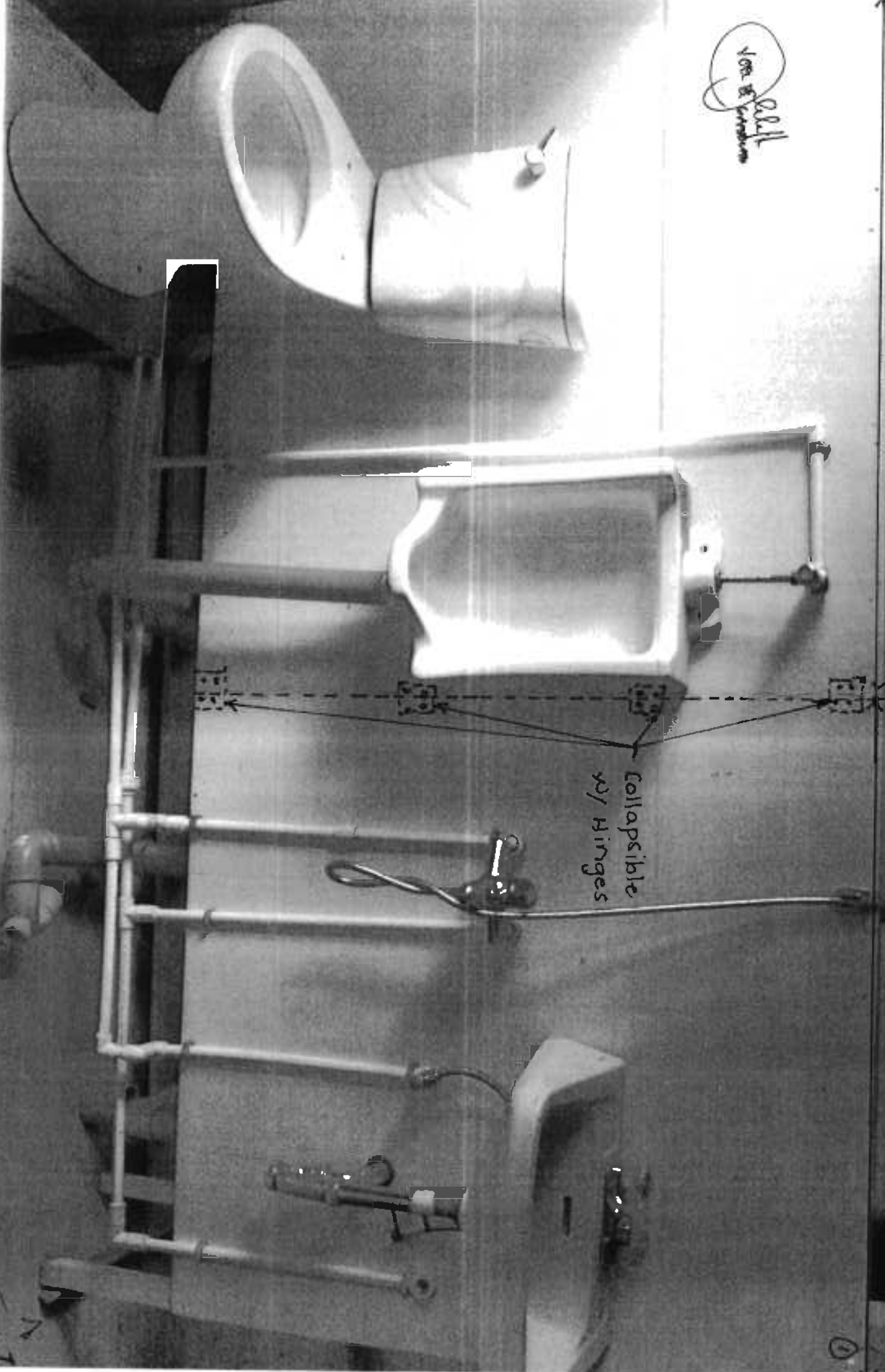

1001 10/20/11

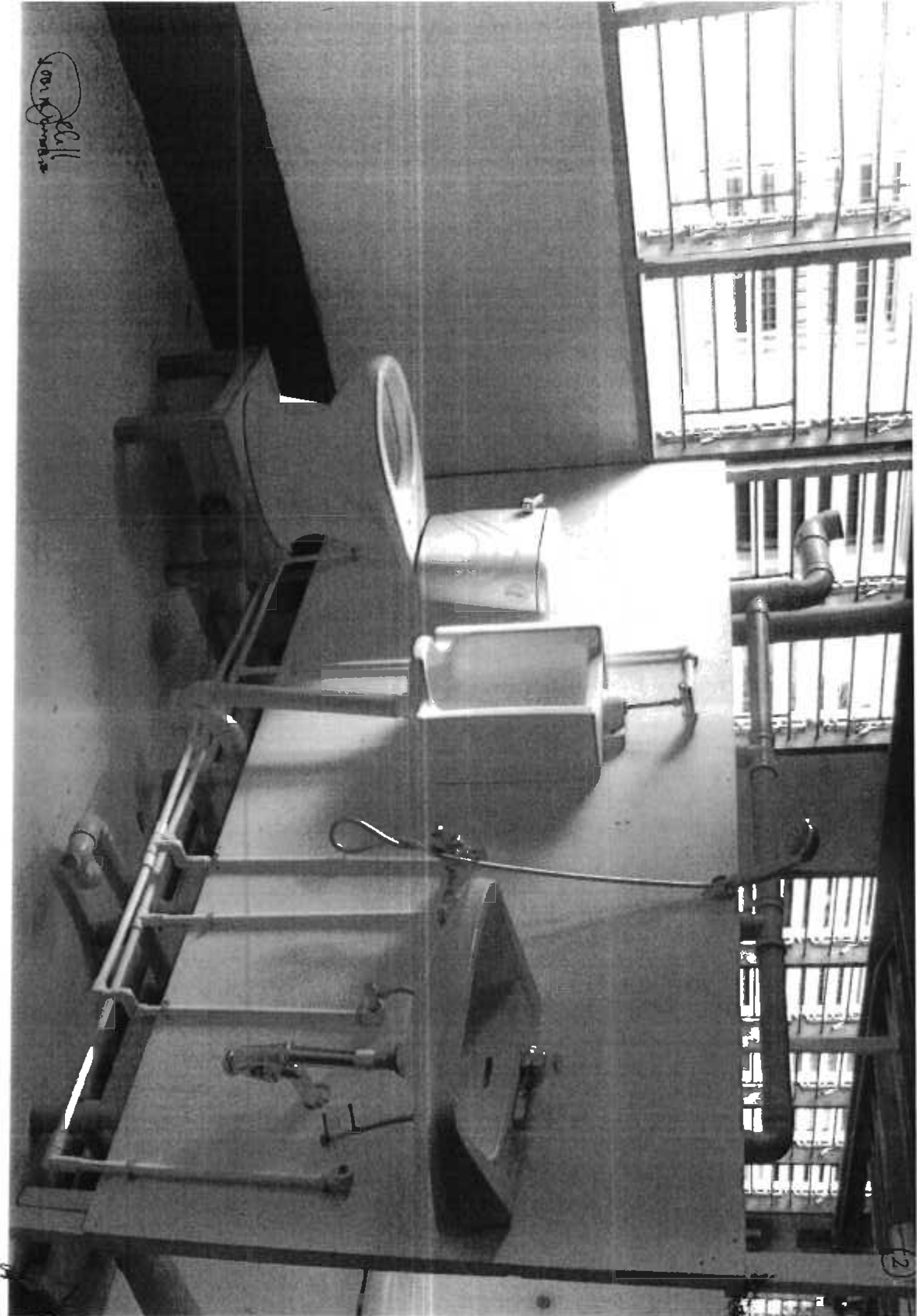

1/16/1974



6

1/16/1974

Never Done

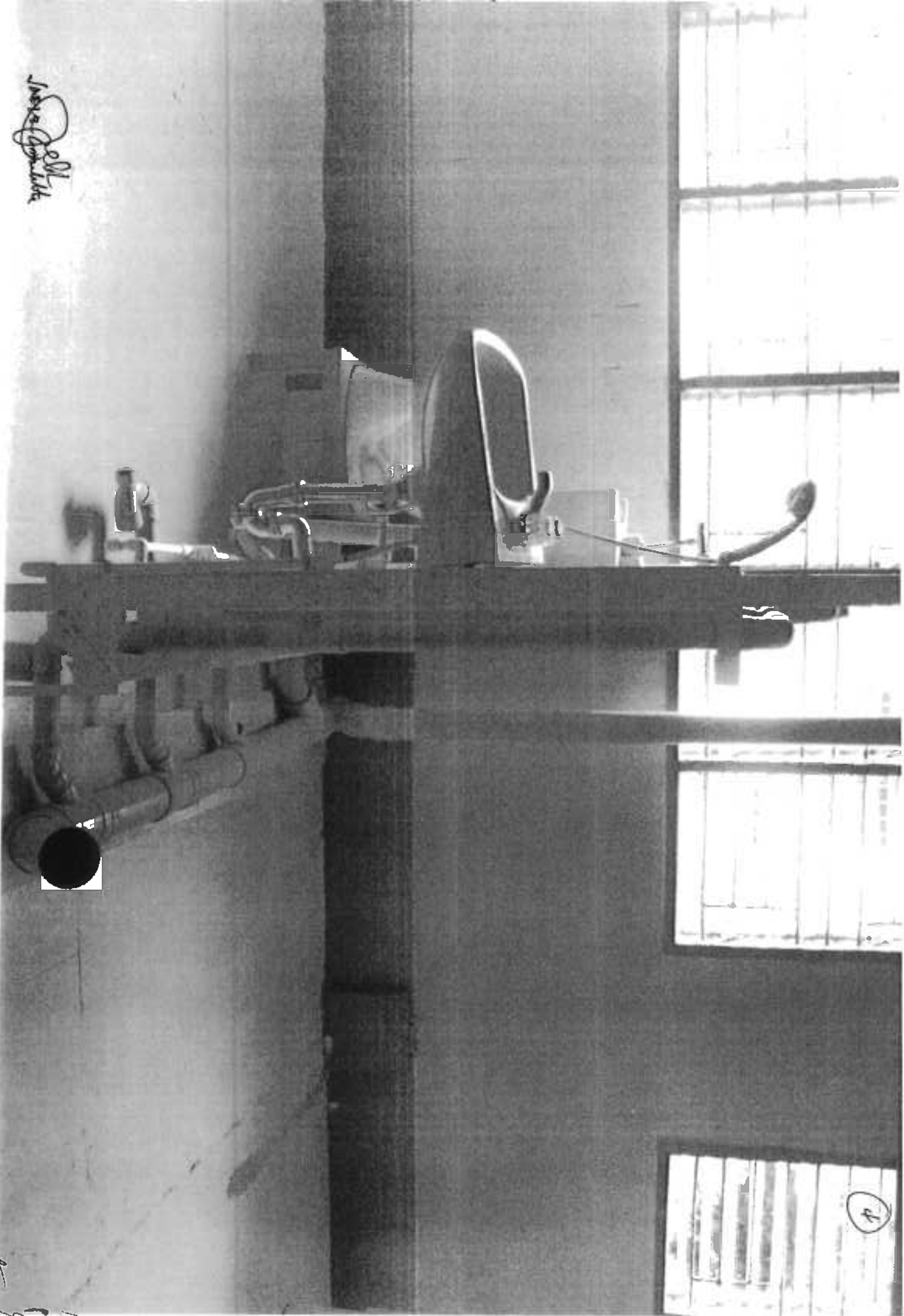

*of
1/2*

(1)

WASTE LINE
 FIRST FLOOR
 SECOND FLOOR
 ISOMETRIC PLUMBING DIAGRAM

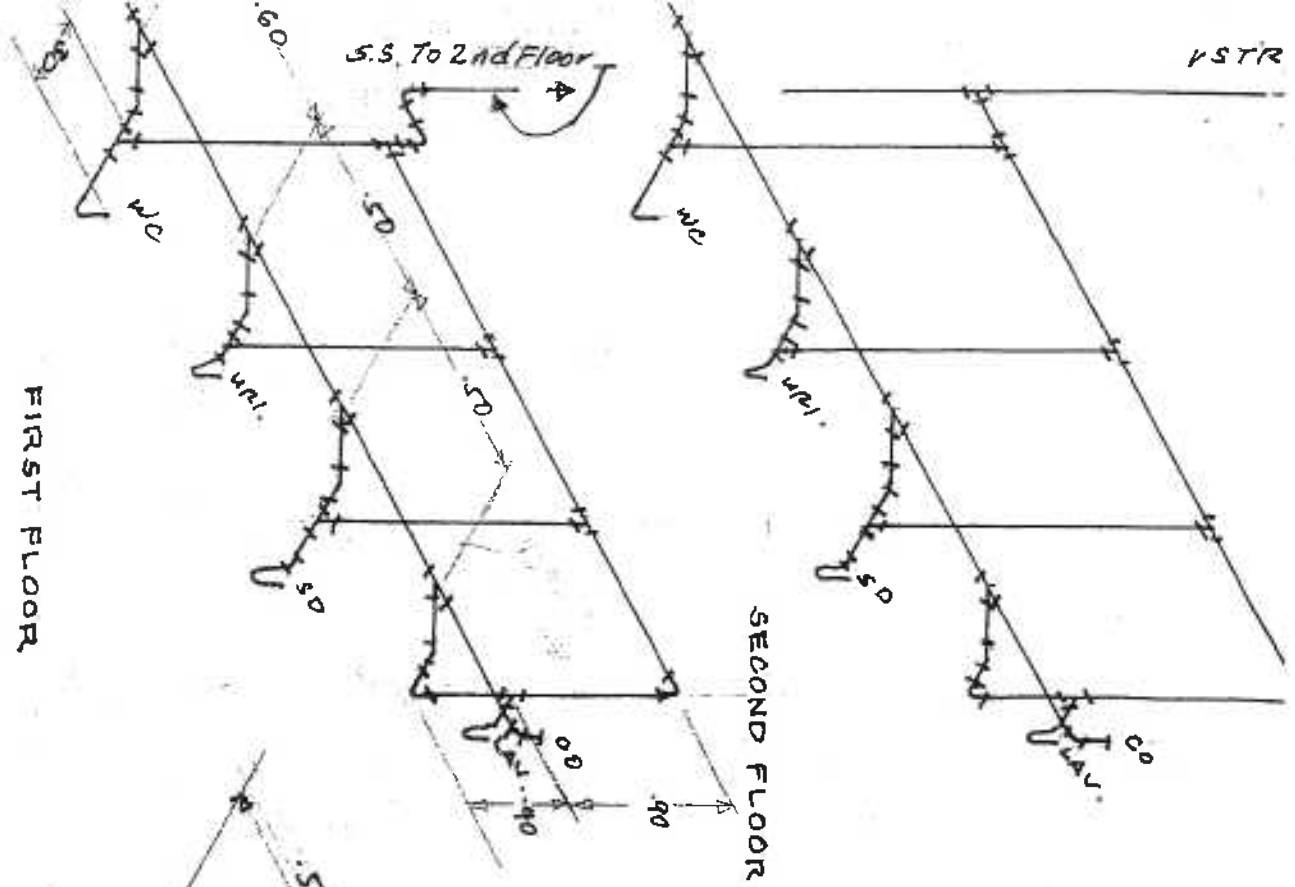

WATER LINE

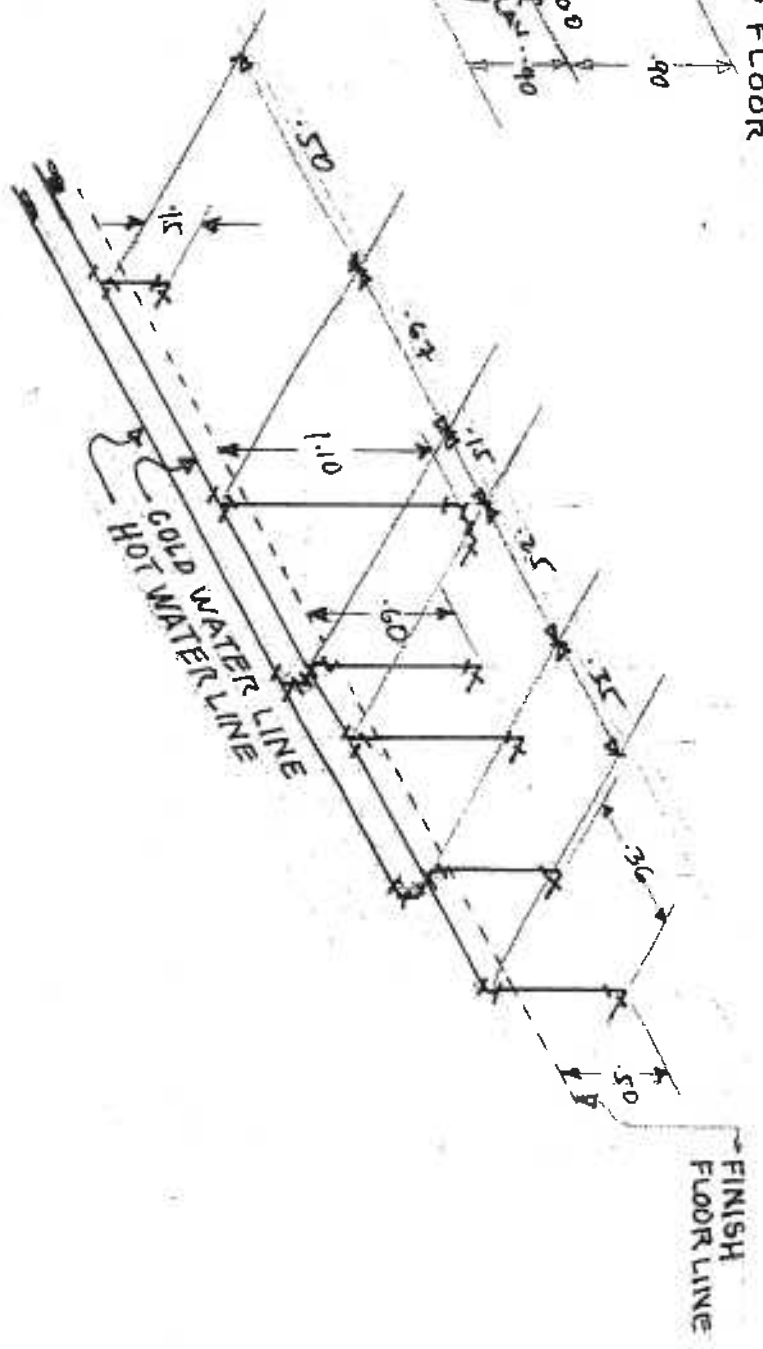

Signature

Handwritten initials

COMPARATIVE TECHNICAL SPECIFICATION

Lot. No. 18 - Small Engine Repair Tools and Equipment Mock-up

| TESDA'S SPECIFICATIONS | | BIDDER'S SPECIFICATIONS | |
|------------------------|---|-------------------------|-----------------------------|
| No. | Item | Item/Brand/Model | Specifications |
| 1 | Motorcycle/Small Engine Collapsible Mock-Up | | |
| 2 | Auto wire | | stranded # 16 |
| 3 | Electrical tape | | large black |
| 4 | Head light assembly | | 12 volts rectangular |
| 5 | signal light assembly | | 12 volts |
| 6 | Horn | | 12 volts |
| 7 | Stop light switch | | push button |
| 8 | Signal light switch | | double throw, toggle switch |
| 9 | Ignition switch | | gas engine type |
| 10 | Signal light relay | | 12 volts |
| 11 | Push button switch | | for horn |
| 12 | Motorcycle storage battery | | 12 volts maintenance free |
| 13 | Harness cover | | 3/8" diameter (140/4) |
| 14 | Harness connector | | 6 terminals |
| 15 | Male terminal | | flat |
| 16 | Female terminal | | flat |

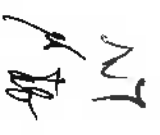
N7

COMPARATIVE TECHNICAL SPECIFICATION

| | | | | |
|----|-----------------------------------|----------------------------------|--|--|
| 17 | Headlight switch or toggle switch | single throw | | |
| 18 | Crocodile clip | medium, red and black | | |
| 19 | stove bolt | 3/16" diameter X 3/4", stainless | | |
| 20 | eye terminal | 3/16" diameter hole | | |
| 21 | Four stroke motorcycle engine | 125 or 155cc, surplus | | |

Name of Bidder: _____

Name and Signature of Authorized Representative: _____
 Position/Designation: _____
 Date: _____

9/17/14

Handwritten initials or marks in the top right corner.

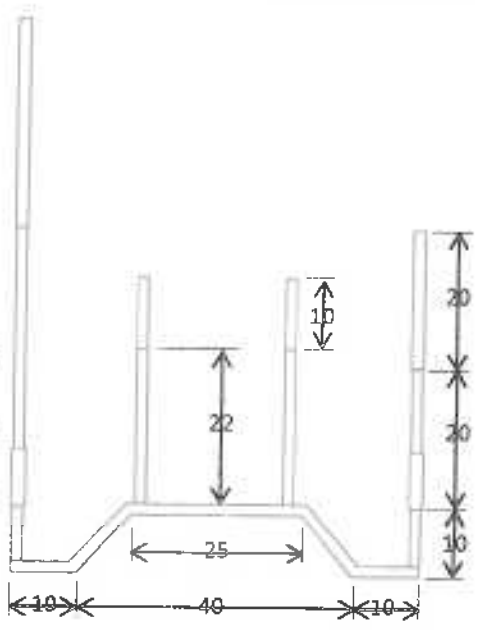
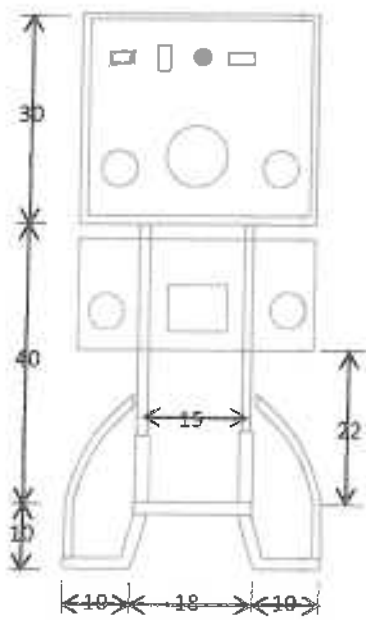
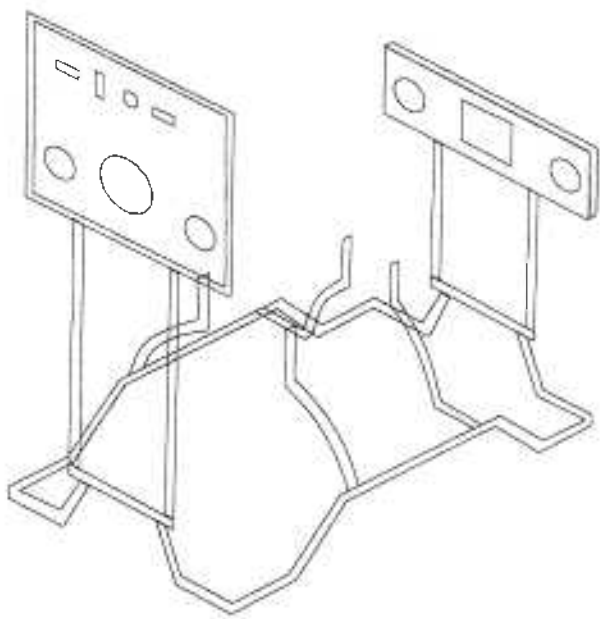
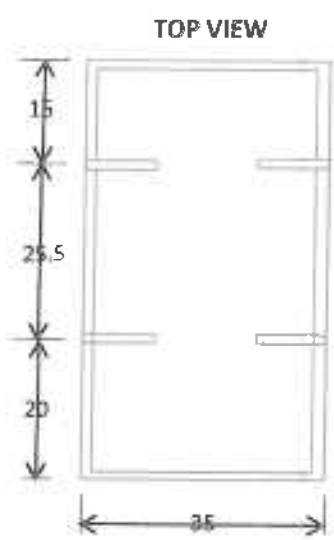

Unit of Measurement = Centimeters
Not Scaled

**MOCK-UP FOR MOTORCYCLE ENGINE
PATTERNED FROM HONDA TMX 155 FRAME**

Handwritten mark or signature at the bottom right.

Handwritten initials or signature in the top right corner.

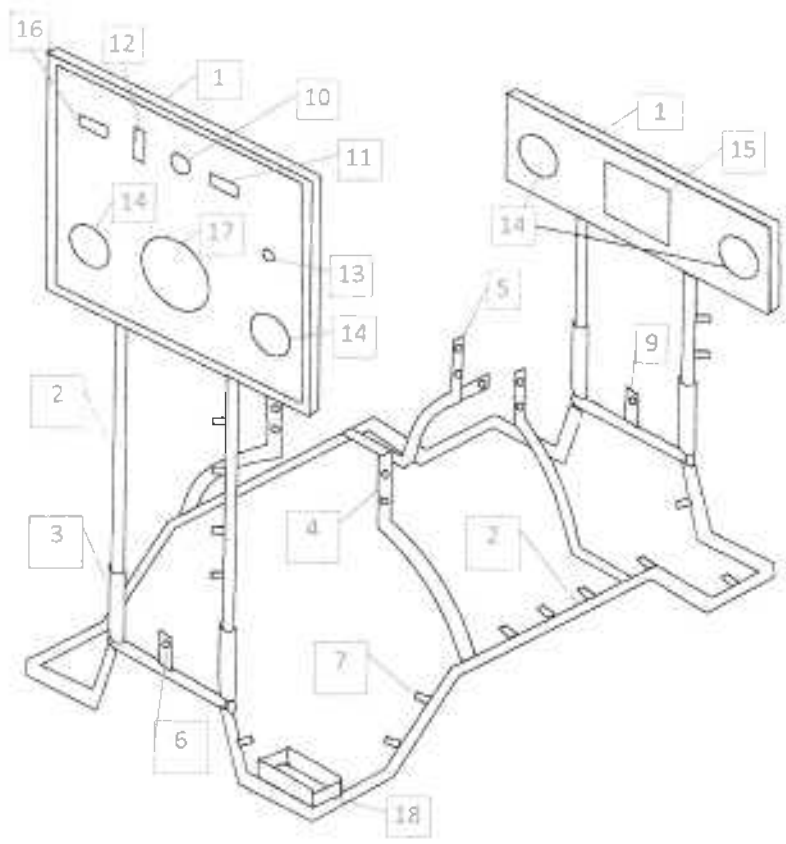

Parts Detail

- 1. G.I. sheet #22
- 2. G.I. pipe 1/2" diameter schedule 40
- 3. G.I. 3/4" diameter schedule 40
- 4. Flat bar, 1/2" x 1 1/2" with 3/8" dia. holes
- 5. Hanger for exhaust pipe
- 6. Provision for stop light switch with 3/8" dia. holes
- 7. Clips for harness 1/8" x 1/2" x 1 1/2", flat bar
- 8. Angle bar, 1/8" x 3/4"
- 9. Provision for horn
- 10. Provision for ignition switch
- 11. Provision for signal light switch
- 12. Provision for dimmer switch
- 13. Provision for signal light relay 3/16" dia.
- 14. Provision for signal light
- 15. Provision for head light
- 16. Provision for head light switch
- 17. Provision for stop light/tail lights
- 18. Provision for battery/ battery holder

BILL OF MATERIALS

- 1 pc 30 cm. x 35 cm. gauge 22, G.I. sheet, for front electrical lighting panel
- 2 pcs 1/8" x 3/4" x 14" } Angle bar, to be assembled into a frame for front
- 2 pcs 1/8" x 3/4" x 12" } electrical lighting panel.
- 1 pc 20 cm. x 35 cm. gauge 22, G. I. sheet, for rear electrical lighting panel.
- 2 pcs 1/8" x 3/4" x 8" } Angle bar, to be assembled into a frame for rear
- 2 pcs 1/8" x 3/4" x 14" } electrical lighting panel.
- 2 pcs 50 cm. x 1/2" dia. G.I. pipe, schedule 40, to support the front electrical lighting panel.
- 2 pcs 30 cm. x 1/2" dia. G.I. pipe, schedule 40, to support the rear electrical lighting panel
- 4 pcs 15 cm. x 3/4" dia. G.I. pipe, schedule 40
- 2 pcs 110 cm. x 1/2" dia. Schedule 40, bent to provide the base support.
- 2 pcs 1/2" x 1 1/2" x 15" with 3/8" holes to mount the front of motorcycle engine support base.
- 2 pcs 1/2" x 1 1/2" x 15" with 3/8" inch holes to mount the rear motorcycle engine support base
- 18 pcs 1/8" x 1/2" x 1 1/2" to serve as clips for harness.
- 2 pcs 3/16" x 1" x 6" angle bar } for battery holder
- 2 pcs 3/16" x 1" x 3" angle bar }
- 2 pcs 5/16" dia. X 4" } machinist's bolt
- 12 pcs 3/8" dia. X 4" }

Equipment

- 1 pc. Four stroke motorcycle engine, 125cc or 155cc

Handwritten signature or initials at the bottom right of the page.

Handwritten initials or signature in the top right corner.

Electrical supplies for motorcycle/small engine per mock-up

- 1 roll auto wire, stranded, #16
- 2 pcs electrical tape, large
- 1 pc head light assembly, 12 volts, rectangular
- 2 pairs signal light assembly, 12 volts
- 1 pc tail/stop light assembly, 12 volts
- 1 pc horn, 12 volts
- 1 pc stop light switch,
- 2 pcs signal light switch, double-throw, toggle switch
- 1 pc ignition switch, gas engine type
- 1 pc signal light relay, Bosch/surplus, 12 volts
- 1 pc push button switch for horn
- 1 pc motorcycle storage battery, 12 v., maintenance free
- 4 meters harnesscover, plastic, 3/8" diameter
- 4 pcs harness connector, 6 terminals
- 30 pcs male terminal, flat, utilux
- 30 pcs female terminal, flat, utilux
- 1 pc headlight switch or toggle switch, single-throw

Mr. Roy Tumanguil
Small Engine Servicing
JZGMSAT

SUMMARY OF COMPUTATION

Approved Budget for the Contract per Lot

MOBILE TRAINING LABORATORY for Storage Purposes of Tools and Equipment, Multimedia & Accessories and Mock-up

| Lot No. | Box No. | Qty. | Unit | Item / Description | Agency Estimate per Unit/Item | No. of Boxes | Total Agency Estimate |
|---------|---------|------|------|--|-------------------------------|--------------|-----------------------|
| 1 | 1 | 1 | unit | Common Box for Multimedia Equipment & Accessories and Mock-up | 32,158.99 | 88 | 2,829,991.12 |
| 2 | 2 | 1 | unit | Appliance Repair NC II with Toolbox | 37,160.54 | 10 | 371,605.40 |
| 3 | 3 | 1 | unit | Bread and Pastry NC II | 33,495.35 | 9 | 301,458.15 |
| | 4 | 1 | unit | Bread and Pastry NC II | 33,495.35 | 9 | 301,458.15 |
| 4 | 5 | 1 | unit | Cookery NC II with Plastic Box | 36,147.23 | 16 | 578,355.68 |
| 5 | 6 | 1 | unit | Electrical Installation and Maintenance NC II with Toolbox | 37,160.54 | 9 | 334,444.86 |
| 6 | 7 | 1 | unit | Food Processing NC II with Plastic Box | 35,845.82 | 12 | 430,149.84 |
| 7 | 8 | 1 | unit | Plumbing NC II | 32,387.08 | 8 | 259,096.64 |
| 8 | 9 | 1 | unit | Small Engine Repair (Motorcycle/Small Engine Servicing NC II) with Toolbox | 38,431.12 | 10 | 384,311.21 |
| | 10 | 1 | unit | Small Engine Repair (Motorcycle/Small Engine Servicing NC II) with Toolbox | 36,404.50 | 10 | 364,045.00 |
| | | | | TOTAL | | | 6,154,916.05 |

TAN
96
AS

MOBILE TRAINING LAB (MTL) TOOLS AND EQUIPMENT
Approved Budget for the Contract per Lot

| Item No. | Qty | Unit | ITEM | AGENCY SPECS | AMOUNT | NO. OF BENEFICIARIES | TOTAL COST |
|---|-----|------|--|---|--------|----------------------|------------|
| Lot No. 9 - Appliance Repair NC II Tools and Equipment (for training purposes) | | | | | | | |
| 1 | 25 | unit | Soldering Iron | dual wattage, 25 watts/ 120watts, 220 volt 60 Hz, with long life tip, "gun type" | | | |
| 2 | 25 | unit | Desoldering Tools | desoldering pump with precision regulated return, replacement tip compact, metal housing | | | |
| 3 | 5 | set | Screw driver assorted (Phillips and slotted) | 12x7x1 inches, 6 pieces per set, plastic handle | | | |
| 4 | 5 | pc | Long Nose Plier | dyna grip, 152mm/6" inches carbon steel | | | |
| 5 | 5 | pc | Diagonal Cutting Plier | dyna grip, 152mm/6" inches carbon steel | | | |
| 6 | 5 | set | Nut Drivers | rust-resistant, nickel-plated bar, hexagonal shank, includes 5mm, 6mm, 7mm, 8mm, 9mm, 10mm, 11mm | | | |
| 7 | 5 | set | Wrench, Combination | 6mm, 8mm, 10mm, 11mm, 12mm, 13mm, 14mm, 15mm, 16mm, 17mm, 19mm, 21mm, 22mm, 24 mm, chrome vanadium steel | | | |
| 8 | 10 | pc | Wire Stripper | automatic, cap 1.5mm to 3.5mm | | | |
| 9 | 5 | pc | Ballpeen hammer | 12 oz, 11 1/2" overall length forged steel construction, hardened and tempered, wooden handle | | | |
| 10 | 5 | pc | Flashlight | LED, 3 volts/6 volts, rechargeable | | | |
| 11 | 5 | pc | Detector Light | test light, 220 volts | | | |
| 12 | 25 | pc | Paint Brush | 4 inches width, wooden handle | | | |
| 13 | 1 | unit | Microwave Oven | power capacity: 220V 1300 watts, interior capacity 20 litres, 8 programmes, defrost option, 26cm diameter rotating turntable, digital | | | |
| 14 | 1 | unit | Washing Machine with dryer | power capacity: 500w, 220V, rust proof body, gear drive system, dolphin drive puluator, washing capacity (dry weight) 7.5kg, spinning capacity (dry weight) 5.5kg, width should be more than 50 cm and length of not more than 100 cm | | | |
| 15 | 1 | unit | Electric Fan | power capacity: 220V, 100w, 60Hz, 3 speed rotary switch, 18 inch metal blade, round/stable plastic base, thermal fuse protection, adjustable height stand fan | | | |
| 16 | 1 | unit | Electric Rice Cooker | power capacity: 700w, 220V, 60Hz, automatic cooking feature, auto shutoff, glass lid, non-stick coated aluminum pan, includes measuring cup and rice scoop | | | |
| 17 | 1 | unit | Electric Flat Iron | power capacity: 1000w, 220V, 60 Hz, non-stick teflon soleplate, thermal fuse protected, variable temperature control, automatic thermostat Control, pilot lamp indicator | | | |
| 18 | 1 | unit | Coffee Maker | power capacity: 550w, 220V, 60Hz, glass pitcher, anti-drip feature, 6 cup water capacity, water level indicator, swing-out filter basket | | | |

Handwritten signature/initials

| Item No. | Qty | Unit | ITEM | AGENCY SPECS | AMOUNT | NO. OF BENEFICIARIES | TOTAL COST |
|----------|-----|------|----------------|--|--------|----------------------|------------|
| 19 | 1 | unit | Oven Toaster | power capacity: 1000w, 220V, 60Hz, stainless steel, 8 liter capacity, 15 minute timer, slide out chrome crumb rack, includes baking tray | | | |
| 20 | 1 | unit | Blender | 1.5 liter capacity, rated voltage, 230V, 60Hz, power consumption: 300 watts, sharp stainless steel blade, safety lock switch, with plastic stirrer for easy mixing | | | |
| 21 | 25 | unit | Multi Tester | analog, standard size analog multimeter for measuring voltage, current and resistance. An auxiliary connector is also provided for checking transistors. SPECIFICATION <ul style="list-style-type: none"> •DC Voltage Range: 0 to 1000V in seven ranges •AC Voltage Range: 0 to 1000V in five ranges •DC Current Range: 0 to 250mA in four ranges •Resistance Range: x1 to 200MEG in four ranges •Transistor hFE Range: -0 to 1000 •Transistors Leakage Current (ICEO) Range: -0 to 150mAAAF Output Range: -10dB to +22dB | | | |
| 22 | 25 | unit | Multi Tester | Digital Multi meters are standard digital multimeter for measuring voltage, current, and resistance with 3-1/2 digit LCD display. This meter measures only 138mm x 70mm x 32mm and weighs approximately 140 grams, including battery. SPECIFICATION: <ul style="list-style-type: none"> •DC Voltage Range: 200mV to 600V in five ranges (auto ranging) •AC Voltage Range: 2V to 600V in four ranges (auto ranging) •DC Current Range: 200mA to 10A in six ranges •Resistance Range: 200 Ohms to 20M in six ranges Transistor hFE Test Range: 0 to 2000 | | | |
| 23 | 1 | unit | Laptop | 15.6", Core i7, 1.40GHz, wide screen, 1TB hard drive, 8GB DDR3 memory, NVIDIA GTX 670MX graphic processor, 3GB video memory, Gigabit 10/100/1000Mbps IEEE802.11b/g/n Wireless LAN, web camera, HDMI, Bluetooth, USB2.0, USB3.0, with Windows 8 OS, up to 6 hours charge-in-use battery, DVDRW super Multi with 1 year warranty | | | |
| 24 | 1 | unit | MS Office 2013 | Home & Student 1 user | | | |
| 25 | 1 | unit | Projector | LCD Projector Portable, RGB liquid crystal shutter projection system (3LCD), White Light Output 2,600 lumens, Colour Light Output 2,600 lumens, XGA Resolution, lightweight less than 2 kgs. | | | |
| 26 | 1 | pc | HDMI cable | 3 meters, v1.4A HDMI cable for Projector | | | |
| 27 | 1 | pc | Whiteboard | wooden whiteboard (2' x 3') with frame, 1 meter collapsible high stand | | | |
| 28 | 1 | unit | PA System | 550W Portable with Trolley, with 2 wireless mics, 220V, RCA port, with warranty | | | |
| 29 | 1 | unit | Megaphone | with speak and music switch and volume control, 25w | | | |

7
20
96
af

| Item No. | Qty | Unit | ITEM | AGENCY SPECS | AMOUNT | NO. OF BENEFICIARIES | TOTAL COST |
|--|-----|---------|-----------------------|--|-------------|----------------------|---------------|
| 30 | 1 | package | First Aid Kit | First Aid Kit with the contents: betadine, alcohol, adhesive strips, band-aid, disposable gloves, hypoallergenic medical tape (1.25 cm x 9.1m), conforming bandage (5cm), triangular bandage (110m x 110cm), wound dressing no. 15, swab antiseptic, tweezers metal 8 cm, scissors disposable, safety pins assorted (12 pcs), hot and cold compress pack, first aid quick reference guide. | | | |
| This include tools and equipment required to maintain and repair electronically controlled domestic appliances | | | | | 395,931.426 | 10 | 3,959,314.256 |
| Lot No. 10 - Bread and Pastry NC II Tools and Equipment (for training purposes) | | | | | | | |
| 1 | 12 | pc | Measuring Cup, dry | stainless steel, 4 pcs/set (1c, 1/2c, 1/3c & 1/4c) | | | |
| 2 | 12 | pc | Measuring Cup, liquid | glass graduated, 250 ml capacity | | | |
| 3 | 12 | set | Measuring Spoon | Stainless steel 6 pcs/set(1/8 tsp, 1/4 tsp, 1/2 tsp, 1 tsp 1/2 tbsp, 1 tbsp) | | | |
| 4 | 10 | pc | Cake Turn Table | plastic cake turntable with locking switch, rubberized feet, white, 12.6x12.6x3.54 inches (LxWxD) | | | |
| 5 | 25 | set | Decorating Tips | stainless steel, 24-piece cake decorating tip set, package size 17cm x 12cm x 5cm (6.69 x 4.72 x 1.97 inches) | | | |
| 6 | 25 | pc | Rolling Pin | wooden, size 33.5 x 5cm, light weight comfortable grip | | | |
| 7 | 10 | pc | Pie Plate, size 6" | aluminum pie pan, 6" diameter x 5/8 in deep, heavy weight round pan | | | |
| 8 | 10 | pc | Pie Plate, size 8" | pie pan, 8" aluminum deep dish pie pan, standard weight aluminum, 8" top outside diameter | | | |
| 9 | 10 | pc | Pie Plate, size 10" | deep aluminum pie pan, 10" diameter, depth 1-1/4", made of 0.7mm thick satin finished aluminum | | | |
| 10 | 10 | pc | Jelly Roll Pan | aluminum, dimension 2" x 13 x 8" (HxWxD) | | | |
| 11 | 10 | pc | Cake Spring Form Pan | heavy aluminum spring form pan, heavy duty frame, spring form sides for easy removal, size 9 x 3" | | | |
| 12 | 10 | pc | Pie Cutter | triple riveted pizza cutter, made of stainless steel, rolling wheel slicer, 6" | | | |
| 13 | 25 | pc | Rubber Scraper | rubber head, high heat resistant, flexible, 12", color white | | | |
| 14 | 25 | pc | Spatula | Stainless steel straight blade, 14 inches long with wood handle | | | |
| 15 | 6 | set | Cake Stand with tier | 3 tier cake round acrylic cake stand, 3 plates clear, size: 15cm, 20cm, 25cm, 10 inches gap between each tier | | | |
| 16 | 15 | pc | Saucepan | Stainless steel with cover and handle 26cm | | | |
| 17 | 10 | pc | Ladle | stainless steel, 12 inches, comes with brush finished handle, hole in the handle for easy hanging | | | |
| 18 | 12 | pc | Chef Knife | 6 inch, stainless steel full tang blade with plastic handle | | | |
| 19 | 10 | pc | Chopping Board | 12 x 17 inches, polyethylene, easy grip handle, white color | | | |
| 20 | 6 | pc | Weighing Scale | manual, maximum weight capacity 2kg, graduated by grams, removable and washable tray | | | |

Handwritten initials and signature

| Item No. | Qty | Unit | ITEM | AGENCY SPECS | AMOUNT | NO. OF BENEFICIARIES | TOTAL COST |
|----------|-----|------|---------------------|--|--------|----------------------|------------|
| 21 | 10 | pc | Grater | made of nonreactive stainless steel easy grip handle | | | |
| 22 | 25 | pc | Wooden Spoon | wooden turner, size 12 Inches | | | |
| 23 | 25 | pc | Piping Bag | 12 inches , light weight, reusable, flexible polyester, coated can be boiled, dishwasher safe | | | |
| 24 | 15 | pc | Mixing Bowl | 12 inches diameter , 8-9 quarts capacity, stainless | | | |
| 25 | 25 | pc | Wire Whisk | 6"/20cm, aluminum, balloon style | | | |
| 26 | 5 | unit | Electric Mixer | 4 qt. stainless steel bowl, 5 speeds & quick burst button, bowl rest TM mixer stabilizer, doubles as a hand mixer. 220V, 280-watts peak power, versatile attachment set includes traditional beaters, whisk and dough hooks, brushed stainless steel | | | |
| 27 | 10 | pc | Dough Cutter | dough scraper 6" wide x 4", high polished stainless steel blade | | | |
| 28 | 1 | unit | Oven (gas) | stainless door, 2 trays oven with tempered glass window, 22-25" collapsible stand | | | |
| 29 | 10 | pc | Pastry Brush | pastry/basting brush, natural wood handle brushes, 1 5" size | | | |
| 30 | 10 | pc | Bread Knife | 8", serrated edge stain free high-carbon steel blade texture red polypropylene handle | | | |
| 31 | 10 | pc | Flour Sifter | stainless steel mesh flour sifter strainer, 12" | | | |
| 32 | 15 | pc | Baking Sheet | aluminum, 13" x 18" | | | |
| 33 | 25 | pc | Muffin Pans | 12 holes, 3 oz. capacity per holes, aluminum | | | |
| 34 | 4 | pc | Working Table | high quality stainless steel foldable tables dimension: 3ft x 3ft | | | |
| 35 | 2 | pc | Gas Stove with tank | 2 burner, made from stainless top body, automatic ignition, with complete accessories | | | |
| 36 | 1 | pc | Kitchen Sink | Kitchen sink, portable single bowl sink stainless steel, with steel collapsible frame legs, with drain hose, Dimension 50cmx50cmx30cm | | | |
| 37 | 5 | pc | Weighing Scale | digital, 1000g, maximum weight capacity, battery operated (AAA battery) 0.1 g to 1000g, LCD display battery included | | | |
| 38 | 1 | unit | Laptop | 15.6", Core i7, 1.40GHz, wide screen, 1TB hard drive, 8GB DDR3 memory, NVIDIA GTX 670MX graphic processor, 3GB video memory, Gigabit 10/100/1000Mbps IEEE802.11b/g/n Wireless LAN, web camera, HDMI, Bluetooth, USB2.0, USB3.0, with Windows 8 OS, up to 6 hours charge-in-use battery, DVDRW super Multi with 1 year warranty | | | |
| 39 | 1 | unit | MS Office 2013 | Home & Student 1 user | | | |
| 40 | 1 | unit | Projector | LCD Projector Portable, RGB liquid crystal shutter projection system (3LCD), White Light Output 2,600 lumens, Colour Light Output 2,600 lumens, XGA Resolution, lightweight, less than 2 kgs | | | |
| 41 | 1 | pc | HDMI cable | 3 meters, v1.4A HDMI cable for Projector | | | |
| 42 | 1 | pc | Whiteboard | wooden whiteboard (2' x 3') with frame, 1 meter collapsible high stand | | | |

N
7
2013

| Item No. | Qty | Unit | ITEM | AGENCY SPECS | AMOUNT | NO. OF BENEFICIARIES | TOTAL COST |
|---|-----|---------|--------------------------|---|-------------|----------------------|---------------|
| 43 | 1 | unit | PA System | 550W Portable with Trolley, with 2 wireless mics, 220V, RCA port, with warranty | | | |
| 44 | 1 | unit | Megaphone | with speak and music switch and volume control, 25w | | | |
| 45 | 1 | package | First Aid Kit | First Aid Kit with the contents: betadine, alcohol, adhesive strips, band-aid, disposable gloves, hypoallergenic medical tape (1 25 cm x 9 1m), conforming bandage (5cm), triangular bandage (110m x 110cm), wound dressing no. 15, swab antiseptic, tweezers metal 8 cm, scissors disposable, safety pins assorted (12 pcs), hot and cold compress pack, first aid quick reference guide | | | |
| This include tools and equipment required in bread making, pastry making, cake making and petits fours making | | | | | 484,823,380 | 9 | 5,408,083,820 |
| Lot No. 11 - Cookery NC II Tools and Equipment (for training purposes) | | | | | | | |
| 1 | 10 | pc | Chef Knife | 8 inch, stainless steel full tang blade with plastic handle | | | |
| 2 | 8 | pc | Boning Knife | 6 inches, stainless steel with sharp cutting edge with plastic handle | | | |
| 3 | 4 | pc | Oyster Knife | 7 inches length (3 inches blade and 4 inches handle), stainless steel blade, with comfortable plastic handle | | | |
| 4 | 2 | pc | Cleaver Knife | 7 inches, stain resistant carbon steel blade | | | |
| 5 | 8 | pc | Tenderizer | with flat and textured side, non slip, 10 inches 25 5 cm. solid aluminum construction | | | |
| 6 | 8 | pc | Skimmer | fine, extra fine mesh, 6 inches diameter, with stainless handle | | | |
| 7 | 8 | pc | Wire Skimmer | small, nickel plated wire oil skimmer, 16 inches long overall, 5 inches diameter bowl | | | |
| 8 | 8 | pc | Skimmer | spider, 5 inches diameter, natural bamboo handle, constructed of durable stainless steel with versatile woven design | | | |
| 9 | 8 | pc | Strainer, small | fine, 6" diameter, with stainless handle | | | |
| 10 | 8 | pc | Siever | small 12" diameter, stainless | | | |
| 11 | 8 | pc | Strainer, medium | medium, fine stainless steel mesh, 9 inches diameter with stainless handle | | | |
| 12 | 8 | pc | Turner | solid, stainless steel with handy loop for hanging, 12 inches long | | | |
| 13 | 8 | pc | Spatula | Stainless steel straight blade, 14 inches long with wood handle | | | |
| 14 | 8 | pc | Wooden Spatula | large comfortable handle, 12 inches long, wooden | | | |
| 15 | 8 | pc | Piping Bag | 12 inches, light weight, reusable, flexible polyester, coated, can be boiled, dishwasher safe | | | |
| 16 | 8 | set | Pastry Tubes | steel stainless, set of 24 pcs, different/assorted icing nozzles medium size, constructed of 18/8 quality stainless steel, comes in plastic storage box with lid | | | |
| 17 | 3 | pc | Strainer, chinois medium | medium, 8 inches diameter, stainless steel including handle | | | |
| 18 | 2 | pc | Strainer, chinois small | small, 5 inches diameter, stainless steel including handle | | | |

Y.N

| Item No. | Qty | Unit | ITEM | AGENCY SPECS | AMOUNT | NO. OF BENEFICIARIES | TOTAL COST |
|----------|-----|------|------------------------|--|--------|----------------------|------------|
| 19 | 4 | set | Funnel | general purpose, hard plastic, comes in 4 different sizes (small, medium, large, extra large) | | | |
| 20 | 6 | set | Measuring Spoon | Stainless steel 6 pcs/set(1/8 tsp, 1/4 tsp, 1/2 tsp, 1 tsp 1/2 tbsp, 1 tbsp) | | | |
| 21 | 8 | pc | Food Tong | 12 inches long, stainless steel, and wide shell head with locking | | | |
| 22 | 8 | pc | Measuring Cup, liquid | glass graduated, 250 ml capacity | | | |
| 23 | 2 | set | Ice Cream Scooper | set of three, stainless steel (2 oz, 4 oz and 6 oz) | | | |
| 24 | 10 | pc | Cheese Cloth | 100% cotton 1 yard | | | |
| 25 | 24 | pc | Serving Spoon | stainless steel, 9 inches long | | | |
| 26 | 4 | pc | Pepper and Salt Mill | 2 in 1, wooden, 8" | | | |
| 27 | 2 | unit | Weighing Scale | analog weighing scale; maximum weight capacity, 5 kg, graduated by grams, removable and washable tray | | | |
| 28 | 2 | unit | Weighing Scale | digital, 1000g, maximum weight capacity, battery operated (AAA battery) 0.1 g to 1000g, LCD display battery included | | | |
| 29 | 4 | pc | Apple Corer | corer head comfortable on slip handle, corer head is stainless steel | | | |
| 30 | 8 | pc | Wire Whisk | 8"/20cm, aluminum, balloon style | | | |
| 31 | 8 | pc | Wire Whisk, medium | medium, 10 inches/25 cm, aluminum, balloon style | | | |
| 32 | 2 | pc | Wire Whisk, large | heavy duty, stainless steel, 14 inches, balloon style | | | |
| 33 | 1 | set | Measuring Cup, dry | stainless steel, 4 pcs/set (1c, 1/2c, 1/3c & 1/4c) | | | |
| 34 | 10 | pc | Chopping Board | 12 x 17 inches, polyethylene, easy grip handle, white color | | | |
| 35 | 8 | pc | Kitchen Scissors | stainless steel blade, size 2 cm x 12 cm x 27 cm, durable and sturdy handle with comfortable grip | | | |
| 36 | 8 | pc | Soup Ladle | 3 oz capacity, stainless steel, with handle, round bottom | | | |
| 37 | 8 | pc | Soup Ladle | 6 oz capacity, stainless steel handle, round bottom | | | |
| 38 | 3 | pc | Soup Ladle | 8 oz capacity, stainless steel handle, round bottom | | | |
| 39 | 2 | pc | Soup Ladle | 12 oz capacity, stainless handle, round bottom, | | | |
| 40 | 10 | pc | Mixing Bowl | 12 inches diameter, 8-9 quarts capacity, stainless | | | |
| 41 | 8 | pc | Kitchen Spoon | solid, stainless steel handle, comfortable non slip handle, round handle 4.5 x 2.5 inches | | | |
| 42 | 8 | pc | Kitchen Spoon | slotted, stainless steel, comfortable non slip handle, round handle 10 x 2.5 inches w/ hole | | | |
| 43 | 8 | pc | Kitchen Fork | 7.5 cm x 4.5 cm x 37 cm or 10.5 inches, stainless steel, with 2 prongs, round handle | | | |
| 44 | 3 | pc | Carving Fork | 10.5 inches, stainless steel, with 2 prongs, round handle | | | |
| 45 | 3 | pc | Pocket Pin Thermometer | analog, temperature range from 0oF to 220 of, dial type | | | |
| 46 | 8 | pc | Peeler | Straight blade type dual stainless steel blade, metal handle 5", 2" handle, 3" blade | | | |

TN

| Item No. | Qty | Unit | ITEM | AGENCY SPECS | AMOUNT | NO. OF BENEFICIARIES | TOTAL COST |
|----------|-----|------|---------------------|--|--------|----------------------|------------|
| 47 | 2 | pc | Stockpot | stainless, 17 quarts capacity (22.7 lit), 12 inches diameter (30.5 cm), depth 31 cm, 4 mm thickness | | | |
| 48 | 2 | pc | Frying pan | pan, large, non stick, 26 cm diameter | | | |
| 49 | 2 | pc | Colander | medium, stainless steel, 8 quarts capacity, with base | | | |
| 50 | 1 | pc | Fish Poacher | medium, 18 inches (L) and 6 inches (w), stainless steel, with handle | | | |
| 51 | 8 | pc | Casserole | small, stainless steel, 20 cm diameter, with cover | | | |
| 52 | 4 | pc | Casserole | medium, stainless steel, 24 cm diameter with cover | | | |
| 53 | 1 | pc | Double Boiler | medium, made from stainless steel, 2 quarts capacity, with lid cover | | | |
| 54 | 4 | pc | Paellera | 40 cm diameter, (50 cm with handle), constructed of carbon steel, riveted secure melt handle, safe for all heating surfaces including induction | | | |
| 55 | 8 | pc | Baking Tray | small, main material is carbon, rectangular, size 14 x 10 inches | | | |
| 56 | 12 | pc | Utility Tray | hard plastic tray, rectangular 14x18 inches | | | |
| 57 | 1 | unit | Fire Extinguisher | cylinder type, multipurpose ABC dry chemical, powder aluminum valve coated, rechargeable, 5 lbs capacity, with pressure gauge that allows for immediate pressure status check, with wall hanger, meets requirements for underwriter laboratory (UL) | | | |
| 58 | 1 | unit | Blender | 1.5 liter capacity, rated voltage, 230V, 60Hz, power consumption: 300 watts, sharp stainless steel blade, safety lock switch, with plastic stirrer for easy mixing | | | |
| 59 | 1 | pc | Pressure Cooker | aluminum, 2 mm, 6 quarts capacity, pressured handle, central pressure valve with self locking mechanism | | | |
| 60 | 4 | unit | Gas Stove with tank | 2 burner, made from stainless top body, automatic ignition, with complete accessories | | | |
| 61 | 4 | pc | Working Table | high quality stainless steel foldable tables dimension: 3ft x 3ft | | | |
| 62 | 1 | unit | Kitchen Sink | Kitchen sink, portable single bowl sink stainless steel, with steel collapsible frame legs, with drain hose, Dimension 50cmx50cmx30cm | | | |
| 63 | 1 | unit | Laptop | 15.6", Core i7, 1.40GHz, wide screen, 1TB hard drive, 8GB DDR3 memory, NVIDIA GTX 670MX graphic processor, 3GB video memory, Gigabit 10/100/1000Mbps IEEE802.11b/g/n Wireless LAN, web camera, HDMI, Bluetooth, USB2.0, USB3.0, with Windows 8 OS, up to 6 hours charge-in-use battery, DVDRW super Multi with 1 year warranty | | | |
| 64 | 1 | unit | MS Office 2013 | Home & Student 1 user | | | |
| 65 | 1 | unit | Projector | LCD Projector Portable, RGB liquid crystal shutter projection system (3LCD), White Light Output 2,600 lumens, Colour Light Output 2,600 lumens, XGA Resolution, lightweight less than 2 kgs. | | | |
| 66 | 1 | pc | HDMI cable | 3 meters, v1.4A HDMI cable for Projector | | | |

7/10/13

| Item No. | Qty | Unit | ITEM | AGENCY SPECS | AMOUNT | NO. OF BENEFICIARIES | TOTAL COST |
|---|-----|---------|-----------------------|--|-------------|----------------------|---------------|
| 67 | 1 | pc | Whiteboard | wooden whiteboard (2' x 3') with frame, 1 meter collapsible high stand | | | |
| 68 | 1 | unit | PA System | 550W Portable with Trolley, with 2 wireless mics, 220V, RCA port, with warranty | | | |
| 69 | 1 | unit | Megaphone | with speak and music switch and volume control, 25w | | | |
| 70 | 1 | package | First Aid Kit | First Aid Kit with the contents: betadine, alcohol, adhesive strips, band-aid, disposable gloves, hypoallergenic medical tape (1.25 cm x 9.1m), conforming bandage (5cm), triangular bandage (110m x 110cm), wound dressing no. 15, swab antiseptic, tweezers metal 8 cm, scissors disposable, safety pins assorted (12 pcs), hot and cold compress pack, first aid quick reference guide. | | | |
| This include tools and equipment in preparing and cooking hot meals | | | | | 406,140.436 | 8 | 3,249,123.488 |
| Lot No. 12 - Electrical Installation and Maintenance NC II Tools and Equipment (for training purposes) | | | | | | | |
| 1 | 1 | pc | Spirit Level | high impact plastic; magnetic; 3 vials; Length 24" | | | |
| 2 | 5 | pc | Hacksaw | adjustable hacksaw frame with bi-metal hacksaw blade, 24 TPI, aluminum alloy frame and handle | | | |
| 3 | 2 | pc | Pipe Cutter | max capacity 1/8-2" for steel or ductile iron pipes with steel handle | | | |
| 4 | 2 | pc | Pipe Reamer | 2" capacity, ratchet type with steel handle, 1/8-2" capacity, suitable for use with power drives | | | |
| 5 | 2 | unit | Pipe Threader | drop head with 3 sets of head and dies, sizes (1/2", 3/4", 1") | | | |
| 6 | 2 | unit | Pipe Bender | manual, 1/2-3/4 inch bending radius, ductile high strength iron | | | |
| 7 | 25 | pc | Electricians Plier | overall length 6, knife length 5/8", material: carbon steel handle finished: plastic dipped | | | |
| 8 | 25 | pc | Long Nose Plier | dyna grip, 152mm/6" inches carbon steel | | | |
| 9 | 25 | set | Phillips Screw Driver | 1x75, PH 2 x 100, PH 2x125 plastic and rubberized handle chrome vanadium, shank 4" | | | |
| 10 | 25 | set | Flat Screw Driver | 3x75, 5x100, 6x125 plastic and rubberized handle chrome vanadium shank 4" | | | |
| 11 | 5 | set | Wrench, Combination | 6mm, 8mm, 10mm, 11mm, 12mm, 13mm, 14mm, 15mm, 16mm, 17mm, 19mm, 21mm, 22mm, 24 mm, chrome vanadium steel | | | |
| 12 | 10 | pc | Wire Stripper | automatic, cap. 1.5mm to 3.5mm | | | |
| 13 | 25 | pc | Electrician Knife | blade length 3", taper ground cutlery single steel blade, ergonomically designed slip resistant grip | | | |
| 14 | 25 | pc | Tool Hoister | leather, 3 pocket & 4 holes with belt | | | |

YN
af

| Item No. | Qty | Unit | ITEM | AGENCY SPECS | AMOUNT | NO. OF BENEFICIARIES | TOTAL COST |
|----------|-----|------|----------------|--|--------|----------------------|------------|
| 15 | 25 | pc | Pull Push Rule | blade length 8 mlrs, blade width 1", high impact ABS case with durable rubber corrosion resistant lru-zero end | | | |
| 16 | 10 | pc | Claw Hammer | 16 oz., forged steel construction, hardened and tempered steel head, smooth face, wooden handle | | | |
| 17 | 2 | unit | Heat Gun | 1600 watts, 230v.60 Hz, 12.5 amp. dual temperature, with different nozzle | | | |
| 18 | 2 | unit | Power Drill | drilling cap. 10mm, cap. wood: 20mm, wattage 350w, no load speed: 0-2500rpm, weight 1.1 kg., Rev - for rotation, 3/8"capacity. 220VAC, 60Hz | | | |
| 19 | 5 | unit | Multi-Tester | analog, standard-size analog multimeter for measuring voltage, current, and resistance. An auxiliary connector is also provided for checking transistors. Specifications: <ul style="list-style-type: none"> •DC Voltage Range: 0 to 1000V in seven ranges •AC Voltage Range: 0 to 1000V in five ranges •DC Current Range: 0 to 250mA in four ranges •Resistance Range: x1 to 20KW in four ranges •Transistor hFE Range: -0 to 1000 •Transistors Leakage Current (ICEO) Range: -0 to 150mAAF Output Range: -10dB to +22dB | | | |
| 20 | 2 | unit | Clamp Ammeter | digital max. AC voltage measurement 600V, max. AC current measurement 400Aac, max. DC voltage measurement 600Vdc, max. resistance measurement 400ohms, battery type AAA, clamp meter type, continuity current, frequency, resistance, voltage, display type LCD, jaw capacity, busbars 10x34mm, safety category voltage, 300V, 600V | | | |
| 21 | 2 | pc | Pipe Vise | capacity 2", material steel, d with swivel base with dual locking nuts, 360 degrees of rotation | | | |
| 22 | 1 | unit | Laptop | 15.6", Core i7, 1.40GHz, wide screen, 1TB hard drive, 8GB DDR3 memory, NVIDIA GTX 670MX graphic processor, 3GB video memory, Gigabit 10/100/1000Mbps IEEE802.11b/g/n Wireless LAN, web camera, HDMI, Bluetooth, USB2.0, USB3.0, with Windows 8 OS, up to 6 hours charge-in-use battery, DVDRW super Multi with 1 year warranty | | | |
| 23 | 1 | unit | MS Office 2013 | Home & Student 1 user | | | |
| 24 | 1 | unit | Projector | LCD Projector Portable, RGB liquid crystal shutter projection system (3LCD), White Light Output 2,600 lumens, Colour Light Output 2,600 lumens, XGA Resolution, lightweight: less than 2 kgs. | | | |
| 25 | 1 | pc | HDMI cable | 3 meters, v1.4A HDMI cable for Projector | | | |
| 26 | 1 | pc | Whiteboard | wooden whiteboard (2' x 3') with frame, 1 meter collapsible high stand | | | |
| 27 | 1 | unit | PA System | 550W Portable with Trolley, with 2 wireless mics, 220V, RCA port, with warranty | | | |
| 28 | 1 | unit | Megaphone | with speak and music switch and volume control, 25w | | | |

7/10/13

| Item No. | Qty | Unit | ITEM | AGENCY SPECS | AMOUNT | NO. OF BENEFICIARIES | TOTAL COST |
|--|-----|---------|-----------------------|---|-------------|----------------------|---------------|
| 29 | 1 | package | First Aid Kit | First Aid Kit with the contents: betadine, alcohol, adhesive strips, band-aid, disposable gloves, hypoallergenic medical tape (1 25 cm x 9 1m), conforming bandage (5cm), triangular bandage (110m x 110cm), wound dressing no. 15, swab antiseptic, tweezers metal 8 cm, scissors disposable, safely pins assorted (12 pcs), hot and cold compress pack, first aid quick reference guide | | | |
| This include tools and equipment in installing wiring devices for floor and ground fault current interrupting outlets and installing electrical lighting systems on auxiliary outlet and lighting fixtures | | | | | 508,687.855 | 9 | 4,578,190.695 |
| Lot No. 13 - Food Processing Tools and Equipment (for training purposes) | | | | | | | |
| 1 | 5 | unit | Weighing Scale | Manual weighing scale, maximum weight capacity, 5 kg, graduated by grams, removable and washable tray | | | |
| 2 | 5 | unit | Weighing Scale | digital, 1000g, maximum weight capacity, battery operated (AAA battery) 0.1 g to 1000g, LCD display battery included. | | | |
| 3 | 25 | pc | Paring Knives | stainless steel blade, 4 inches | | | |
| 4 | 12 | pc | Peeler | Straight blade type, dual stainless steel blade, metal handle 5" 2" handle, 3" blade | | | |
| 5 | 6 | set | Measuring Spoon | Stainless steel 6 pcs/set (1/8 tsp, 1/4 tsp, 1/2 tsp, 1 tsp 1/2 lbsp, 1 lbsp) | | | |
| 6 | 6 | set | Measuring Cup, dry | stainless steel, 4 pcs/set (1c, 1/2c, 1/3c & 1/4c) | | | |
| 7 | 6 | pc | Measuring Cup, liquid | glass graduated, 250 ml capacity | | | |
| 8 | 5 | pc | Clocks/Timer | digital, battery operated, with convenient clip, battery included | | | |
| 9 | 12 | set | Mixing Bowl | 12 inches diameter, 8-9 quarts capacity, stainless | | | |
| 10 | 3 | set | Chopping Board | 12x17 inches, polyethylene, easy grip handle, white color | | | |
| 11 | 5 | pc | Dial Thermometer | stainless steel, 12" stem, stainless clip | | | |
| 12 | 4 | unit | Osterizers | 8 speed with pulse, 500 watts, 220 volts 60 hertz, stainless steel ice crusher blade, 6 cups glass jar capacity, with warranty | | | |
| 13 | 5 | pc | Jar Lifter | non slip handle, rubberized 5" full expansion | | | |
| 14 | 1 | unit | Food Processors | with exact slice system, 2 in one wide mouth feed tube, with high, low, pulse, off operation, adjustable stainless steel slicing disc and ultra tight seal, 220 volts, 60 hertz, 700 watts | | | |
| 15 | 5 | pc | Wire Baskets | stainless steel, rectangular, with handle, 4" x 17.75" x 14" (HxWxD) | | | |
| 16 | 5 | pc | Casseroles | stainless steel, with cover, 5 quarts capacity, with long handles | | | |
| 17 | 5 | pc | Saucepan | stainless steel, with cover and handle, 26 cm | | | |
| 18 | 15 | pc | Spoon, wooden | wooden turner, size 12 inches | | | |
| 19 | 15 | pc | Spoon, basting | 12" long, 100% solid wood, strong and durable | | | |

T. M. H.
as

| Item No. | Qty | Unit | ITEM | AGENCY SPECS | AMOUNT | NO. OF BENEFICIARIES | TOTAL COST |
|----------|-----|------|-----------------------------|---|--------|----------------------|------------|
| 20 | 4 | pc | Paddle, wooden | solid wood, 24 inches length x 3-1/2 inches width | | | |
| 21 | 14 | pc | Food Tong | 12 inches long, stainless steel, and wide shell head with locking | | | |
| 22 | 12 | pc | Kitchen Scissors | stainless steel blade, size 2 cm x 12 cm x 27 cm, durable and sturdy handle with comfortable grip | | | |
| 23 | 4 | pc | Steamer | 6 quarts base pan doubles as a stock pot, aluminum, with cover, 3 layer, 30 cm | | | |
| 24 | 5 | pc | Fermented Containers (pail) | hard plastic, with 16 liter capacity, with cover | | | |
| 25 | 20 | pc | Utility Tray | hard plastic tray, rectangular 14x18 inches | | | |
| 26 | 10 | pc | Colander | medium, stainless steel, 8 quarts capacity, with base | | | |
| 27 | 1 | unit | Smoke House | Width - 25" Height - 40" Length - 15", 3 Layers of Paritya inside, 1" for Tray above the Charcoal, 2" for the box of Charcoal, Gauge of Stainless - 10 Mirror | | | |
| 28 | 3 | unit | Gas Stove with tank | 2 burner, made from stainless top body, automatic ignition, with complete accessories | | | |
| 29 | 2 | unit | Polytemperature Sealer | 300mm long, 220 volts, 60 Hz, 400W | | | |
| 30 | 2 | pc | Pressure Canner | 25 quarts, stainless steel | | | |
| 31 | 3 | pc | Pressure Cooker | 8 quarts, stainless steel | | | |
| 32 | 1 | unit | Electric Oven | 220 V, 60 Hz, 1000W, 18 L capacity, with warranty | | | |
| 33 | 1 | unit | Meat Grinder | (size in cm) 49 x 23 x 29.5, stainless main materials, 220 volts, 60 Hz, 1/2 HP, with warranty | | | |
| 34 | 4 | pc | Casseroles | stainless steel, 10" diameter, with lid | | | |
| 35 | 4 | pc | Working Table | high quality stainless steel foldable tables dimension: 3ft x 3ft | | | |
| 36 | 10 | pc | Chef Knife | 8 inch, stainless steel full tang blade with plastic handle | | | |
| 37 | 1 | unit | Laptop | 15.6", Core i7, 1.40GHz, wide screen, 1TB hard drive, 8GB DDR3 memory, NVIDIA GTX 870MX graphic processor, 3GB video memory, Gigabit 10/100/1000Mbps IEEE802.11b/g/n Wireless LAN, web camera, HDMI, Bluetooth, USB 2.0, USB 3.0, with Windows 8 OS, up to 6 hours charge-in-use battery, DVD RW super Multi with 1 year warranty | | | |
| 38 | 1 | unit | MS Office 2013 | Home & Student 1 user | | | |
| 39 | 1 | unit | Projector | LCD Projector Portable, RGB liquid crystal shutter projection system (3LCD), White Light Output 2,600 lumens, Colour Light Output 2,600 lumens, XGA Resolution, lightweight less than 2 kgs | | | |
| 40 | 1 | pc | HDMI cable | 3 meters, v1.4A HDMI cable for Projector | | | |
| 41 | 1 | pc | Whiteboard | wooden whiteboard (2' x 3') with frame, 1 meter collapsible high stand | | | |

Handwritten signature/initials

| Item No. | Qty | Unit | ITEM | AGENCY SPECS | AMOUNT | NO. OF BENEFICIARIES | TOTAL COST |
|--|-----|---------|-------------------------------|---|-------------|----------------------|---------------|
| 42 | 1 | unit | PA System | 550W Portable with Trolley, with 2 wireless mics, 220V, RCA port, with warranty | | | |
| 43 | 1 | unit | Megaphone | with speak and music switch and volume control, 25w | | | |
| 44 | 1 | package | First Aid Kit | First Aid Kit with the contents: betadine, alcohol, adhesive strips, band-aid, disposable gloves, hypoallergenic medical tape (1 25 cm x 9.1m), conforming bandage (5cm), triangular bandage (110m x 110cm), wound dressing no. 15, swab antiseptic, tweezers metal 8 cm, scissors disposable, safety pins assorted (12 pcs), hot and cold compress pack, first aid quick reference guide | | | |
| This include tools and equipment required in preparing process food by salting, curing, smoking, fermentation and pickling and sugar concentration | | | | | 445,929.470 | 6 | 2,675,576.820 |
| Lot No. 14 - Plumbing NC II Tools and Equipment (for training purposes) | | | | | | | |
| 1 | 5 | pc | Pipe Wrench | 12" straight, heavy duty, forged alloy steel 12", pipe capacity 2" or 50mm, weight 1.2 kg. cast-iron housing and I-beam handle with full floating forged hook jaw, featuring self cleaning threads with replaceable hook and heel jaws | | | |
| 2 | 5 | pc | Pipe Wrench | 14" straight, heavy duty, forged alloy steel 12", pipe capacity 2" or 50mm, weight 1.6 kg. cast-iron housing and I-beam handle with full floating forged hook jaw, featuring self cleaning threads with replaceable hook and heel jaws | | | |
| 3 | 10 | pc | Pull Push Rule | blade length 8 mtrs, blade width 1", high impact ABS case with durable rubber corrosion resistant Iru-zero end | | | |
| 4 | 5 | pc | Hacksaw | adjustable hacksaw frame with bi-metal hacksaw blade, 24 TPI, aluminum alloy frame and handle | | | |
| 5 | 5 | pc | Spirit Level | high impact plastic; magnetic, 3 vials; Length 24" | | | |
| 6 | 5 | pc | Pipe Reamer | 2" capacity, ratchet type with steel handle, 1/8-2" capacity, suitable for use with power drives | | | |
| 7 | 5 | pc | Pipe Cutter | max capacity 1/8-2" for steel or ductile iron pipes with steel handle | | | |
| 8 | 5 | pc | Adjustable Wrench | alloy steel, 0 - 2" jaw opening, 10" length | | | |
| 9 | 5 | pc | Mechanical Plier | mechanical, plastic dipped insulated handle, 6" length, rust-resistant chrome finish, two position adjustable joint pliers | | | |
| 10 | 2 | pc | Pipe Vise | capacity 2", material steel, d with swivel base with dual locking nuts, 360 degrees of rotation | | | |
| 11 | 2 | pc | Pipe Threader | drop head with 3 sets of head and dies, sizes (1/2", 3/4", 1") | | | |
| 12 | 3 | pc | Portable Tri-stand Chain Vise | 1/8 to 6 in., rear pipe support, rugged tool tray capacity: 1/8" - 6", leg locking: over center tool tray | | | |
| 13 | 1 | pc | Manual Pressure Test Pump | 6 mpa, 860 psi max. pressure, 12 L capacity, with brass pump valve | | | |
| 14 | 2 | pc | Socket Fusion Machine | 20 mm - 32 mm cap, 1/4", 1", 1-1/4" and 1-1/2", 220V, 1600w | | | |
| 15 | 5 | pc | Ballpeen hammer | 12 oz, 11 1/2" overall length forged steel construction, hardened and tempered, wooden handle | | | |

TN gureb
DB

| Item No. | Qty | Unit | ITEM | AGENCY SPECS | AMOUNT | NO. OF BENEFICIARIES | TOTAL COST |
|----------|-----|------|---------------------------|--|--------|----------------------|------------|
| 16 | 2 | pc | Angle Grinder | 4" diameter, wheel cap, 220V, 60 Hz, single phase, 11,000 rpm, all-ball bearing design and metal gear | | | |
| 17 | 1 | pc | Electric Portable Drill | 1/2" bit jaw capacity, 220V, single phase, variable speed (0-550 rpm), heavy duty, 1/2" drill chuck | | | |
| 18 | 4 | pc | Carpenter Steel Square | high tempered aluminum steel, 2" x 16" x 24", 5-60 and 30-degree angle markings, high tempered aluminum for maximum durability, 1/8-inch graduations for long-term visibility, body 24 by 2-inches, tongue: 16 by 1-1/2" | | | |
| 19 | 5 | pc | Claw Hammer | 16 oz., forged steel construction, hardened and tempered steel head, smooth face wooden handle | | | |
| 20 | 10 | pc | Paint Brush | 1/2" round trim brush soft bristle, tin-plated ferrules | | | |
| 21 | 25 | pc | Hand Gloves | 5 finger, poly/cotton blend with a latex coated palm | | | |
| 22 | 25 | pc | Safety Hard Hat | V-rib, yellow ball-cap style hard hat with 6 point ratchet-type headgear, 2 point chin strap and V rib on top, polyethylene material | | | |
| 23 | 25 | pc | Safety Shoes | heavy duty steel toe cap, waterproof, anti static (sizes 40-42) l/s anti-static and heat resistant (up to 300 degree C/572 degree F) with TPU SAFETY cell construction steel toe cap | | | |
| 24 | 25 | pc | Safety Goggles | clear polycarbonate, woven elastic strap (adjustable) | | | |
| 25 | 1 | pc | Water Meter | multi jet plastic meter, 1/2" NPT, 20 gpm, brass body | | | |
| 26 | 1 | pc | Water Closet | flush type, ceramic, dimension (LxWxH): 664x430x767 mm, flushing action: siphonic, single/dual flush: single flush, flush Volume: 6L, flushing activation: front lever, rough-in: 305mm, discharge: floor cover | | | |
| 27 | 2 | pc | Lavatory with Faucet | center hole, with mixing hot and cold faucet, ceramic, wall hung type, wall hung sink, 4-inch center faucet holes, front overflow, self-draining deck area with contoured back and side splash shields | | | |
| 28 | 1 | pc | Kitchen Sink with Faucet | stainless steel, rust and heat resistant, grade 304, 74 cm x 51.5 cm, 16.2 mm outlet hole | | | |
| 29 | 2 | pc | Single Point Water Heater | 4.5kw, 220V, 60 Hz, 2 psi min water pressure, 55 psi, 2 L/min minimum waterflow, 1/2" BSP | | | |
| 30 | 1 | unit | Laptop | 15.6", Core i7, 1.40GHz, wide screen, 1TB hard drive, 8GB DDR3 memory, NVIDIA GTX 670MX graphic processor, 3GB video memory, Gigabit 10/100/1000Mbps IEEE802.11b/g/n Wireless LAN, web camera, HDMI, Bluetooth, USB2.0, USB3.0, with Windows 8 OS, up to 6 hours charge-in-use battery, DVDRW super Multi with 1 year warranty | | | |
| 31 | 1 | unit | MS Office 2013 | Home & Student 1 user | | | |
| 32 | 1 | unit | Projector | LCD Projector Portable, RGB liquid crystal shutter projection system (3LCD), White Light Output 2,600 lumens, Colour Light Output 2,600 lumens, XGA Resolution, lightweight: less than 2 kgs. | | | |

TN pd
atg

| Item No. | Qty | Unit | ITEM | AGENCY SPECS | AMOUNT | NO. OF BENEFICIARIES | TOTAL COST |
|---|-----|---------|----------------------------|--|-------------|----------------------|---------------|
| 33 | 1 | pc | HDMI cable | 3 meters, v1 4A HDMI cable for Projector | | | |
| 34 | 1 | pc | Whiteboard | wooden whiteboard (2' x 3') with frame, 1 meter collapsible high stand | | | |
| 35 | 1 | unit | PA System | 550W Portable with Trolley, with 2 wireless mics, 220V, RCA port, with warranty | | | |
| 36 | 1 | unit | Megaphone | with speak and music switch and volume control, 25w | | | |
| 37 | 1 | package | First Aid Kit | First Aid Kit with the contents: betadine, alcohol, adhesive strips, band-aid, disposable gloves, hypoallergenic medical tape (1 25 cm x 9.1m), conforming bandage (5cm), triangular bandage (110m x 110cm), wound dressing no. 15, swab antiseptic, tweezers metal 8 cm, scissors disposable, safety pins assorted (12 pcs), hot and cold compress pack, first aid quick reference guide. | | | |
| This include tools and equipment required in making piping joints and performing single unit plumbing installation and assemblies | | | | | 694,734.373 | 8 | 5,557,874.984 |
| Lot No. 15 - Small Engine Repair (Motorcycle/Small Engine Servicing NC II) | | | | | | | |
| Tools and Equipment (for training purposes) | | | | | | | |
| 1 | 10 | set | Impact Drive Tool | 4pcs. 1/2" Impact Driver Set, heavy duty | | | |
| 2 | 10 | pc | Multi-Tester | analog, standard-size analog multimeter for measuring voltage, current, and resistance. An auxiliary connector is also provided for checking transistors. Specifications: •DC Voltage Range: 0 to 1000V in seven ranges •AC Voltage Range: 0 to 1000V in five ranges •DC Current Range: 0 to 250mA in four ranges •Resistance Range: x1 to 20KW in four ranges •Transistor hFE Range: -0 to 1000 •Transistors Leakage Current (ICEO) Range: -0 to 150µA •Output Range: -10dB to +22dB | | | |
| 3 | 10 | pc | Oiler | metal case, 1/2 liter cap | | | |
| 4 | 10 | pc | Steel Brush | wooden handle | | | |
| 5 | 10 | pc | Hacksaw | adjustable hacksaw frame with bi-metal hacksaw blade, 24 TPI, aluminum alloy frame and handle | | | |
| 6 | 10 | pc | Center Punch | high speed steel, 5x125 mm | | | |
| 7 | 10 | pc | Cold Chisel | flat blade, 1" (W), 6" (L), hardened steel | | | |
| 8 | 10 | pc | Fly Wheel/Magneto Puller | universal type, six in one fly wheel/magneto puller | | | |
| 9 | 10 | set | Oil Seal Remover/Installer | pointed tip, hardened steel w/ straight handle, 3 pcs per set | | | |
| 10 | 10 | pc | Piston Ring Compressor | self locking w/ L wrench steel, range 2 1/8" to 5 inch diameter | | | |
| 11 | 10 | pc | Valve Spring Compressor | spring loaded offset jaw overhead valve spring compressor, steel | | | |
| 12 | 10 | pc | Clutch Assembly Remover | universal compressor clutch hub for removal and installation | | | |
| 13 | 10 | pc | Electricians Plier | overall length 6, knife length: 5/8", material: carbon steel handle finished: plastic dipped | | | |

TW
atg

COMPARATIVE TECHNICAL SPECIFICATION

| LOT 17 - Plumbing Mock-up | | TESDA'S SPECIFICATIONS | | BIDDER'S SPECIFICATIONS | |
|---------------------------|-------------------------------|------------------------|------------------|-------------------------|--|
| No. | Item | Specifications | Item/Brand/Model | Specifications | |
| 1. | Plumbing Mock-up (Labor Cost) | | | | |
| 2. | PVC Pipe | 4" dia (Orange) | | | |
| 3. | PVC Elbow | 4" dia. 90 deg. | | | |
| 4. | PVC Elbow | 4" dia. 45 deg. | | | |
| 5. | PVC Clean Out | 4" dia. | | | |
| 6. | PVC Wye | 4" x 3" | | | |
| 7. | PVC Wye | 4" x 2" | | | |
| 8. | PVC pipe | 3" dia. | | | |
| 9. | PVC Elbow | 3" | | | |
| 10. | PVC Elbow | 3" 45 deg. | | | |
| 11. | PVC Tee | 3" x 2" | | | |
| 12. | PVC Tee | 3" x 3" | | | |
| 13. | PVC Pipe | 2" dia | | | |
| 14. | PVC Elbow | 2" dia. 45 deg. | | | |

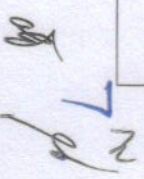
7/21

COMPARATIVE TECHNICAL SPECIFICATION

| | | | | |
|-----|---------------------|---|--|--|
| 15. | PVC Elbow | 2" dia. 90 deg. | | |
| 16. | PVC Tee | 2" | | |
| 17. | PVC P-trap | 2" | | |
| 18. | PPr pipe | 1/2" dia. | | |
| 19. | PPr elbow | 1/2" dia. | | |
| 20. | PPr tee | 1/2" dia. | | |
| 21. | PPr elbow connector | 1/2" dia. | | |
| 22. | PPr male connector | 1/2" dia. | | |
| 23. | PPr union | 1/2" dia. | | |
| 24. | PPr coupling | 1/2" dia. | | |
| 25. | Urinal | 480mm X 730mm X 730mm with complete accessories | | |
| 26. | Shower head | with complete accessories | | |
| 27. | flexible hose | 1/2 x 7/8 | | |
| 28. | angle valve | 1/2 x 1/2" | | |
| 29. | Marine Plywood | 3/4" x 4' x 8' | | |

of 12

COMPARATIVE TECHNICAL SPECIFICATION

| | | | | |
|-----|--------------|----------------------|--|--|
| 30. | Lumber | 2" x 2" x 12' | | |
| 31. | Teflon Tape | | | |
| 32. | Metal hinges | 2" X 4" , heavy duty | | |

Name of Bidder: _____

Name and Signature of Authorized Representative: _____
Position/Designation: _____
Date: _____

John
as

Roll
100% B. L. L. L.

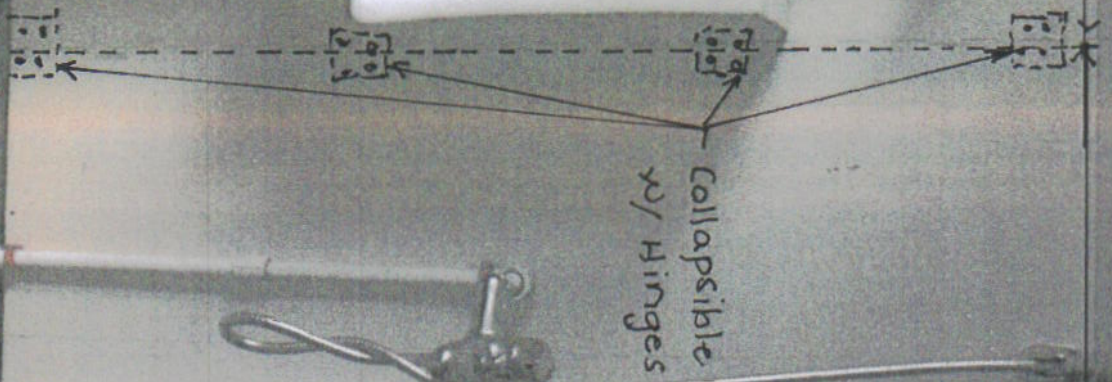

Collapsible
w/ Hinges

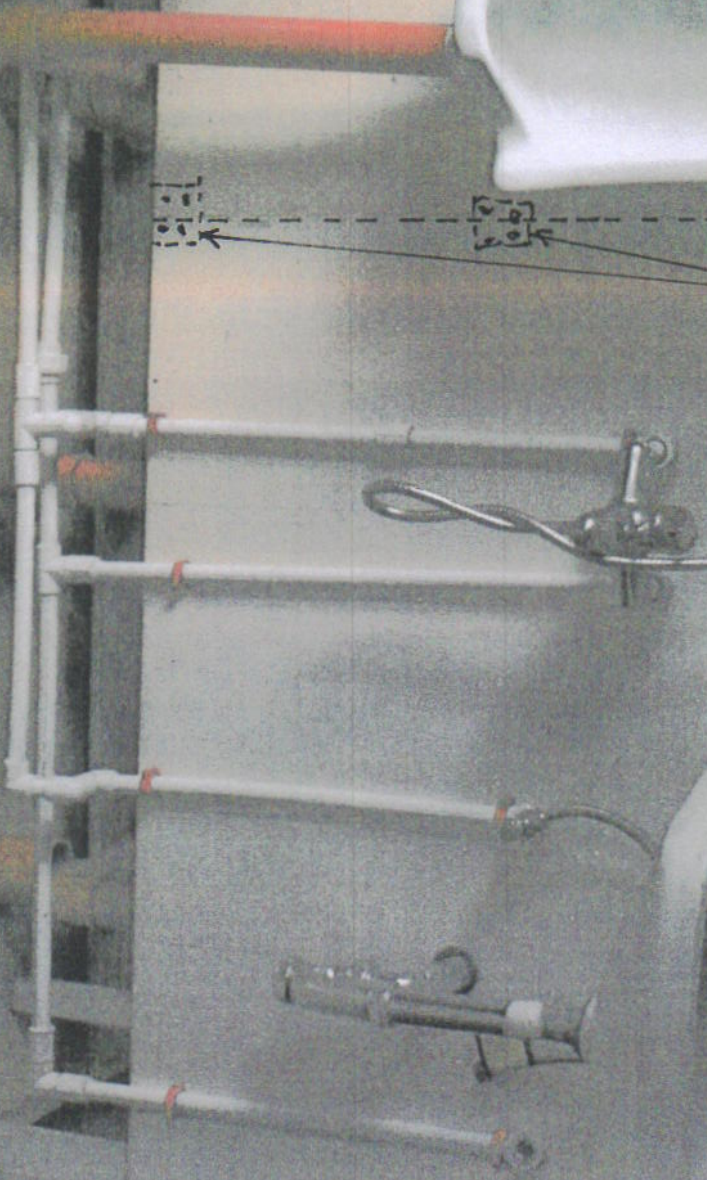

4/1

1

1001 10/10/10



2

10/10/10

1481271000000



1481271000000

6

James J. Connelly

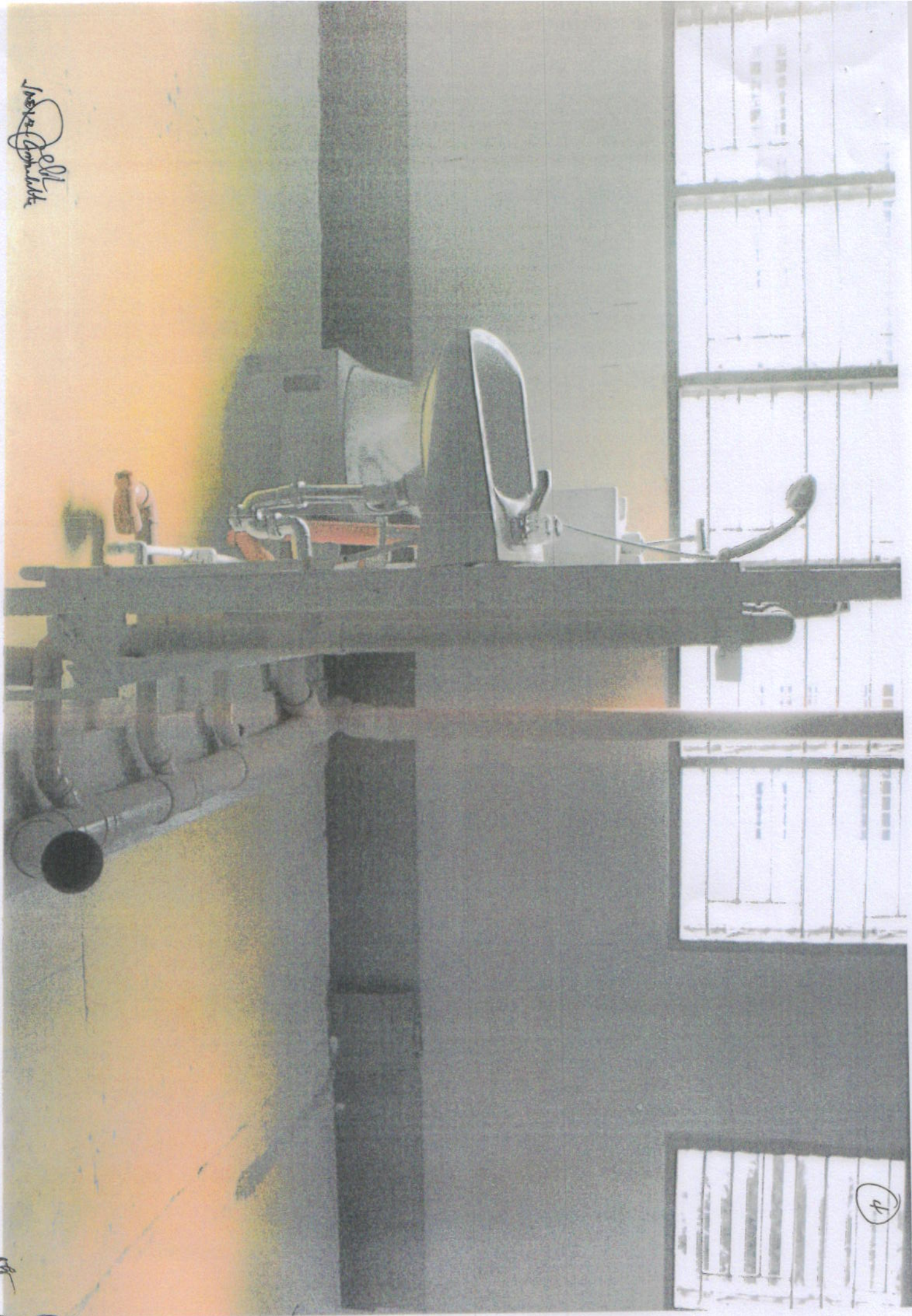

of
2/2/02

(4)

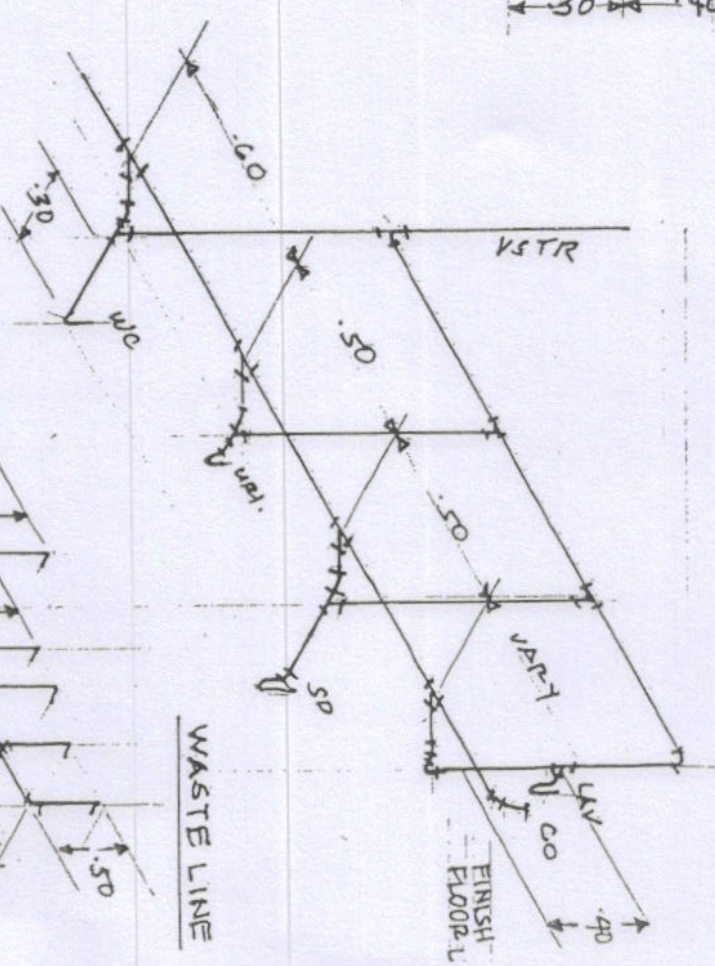
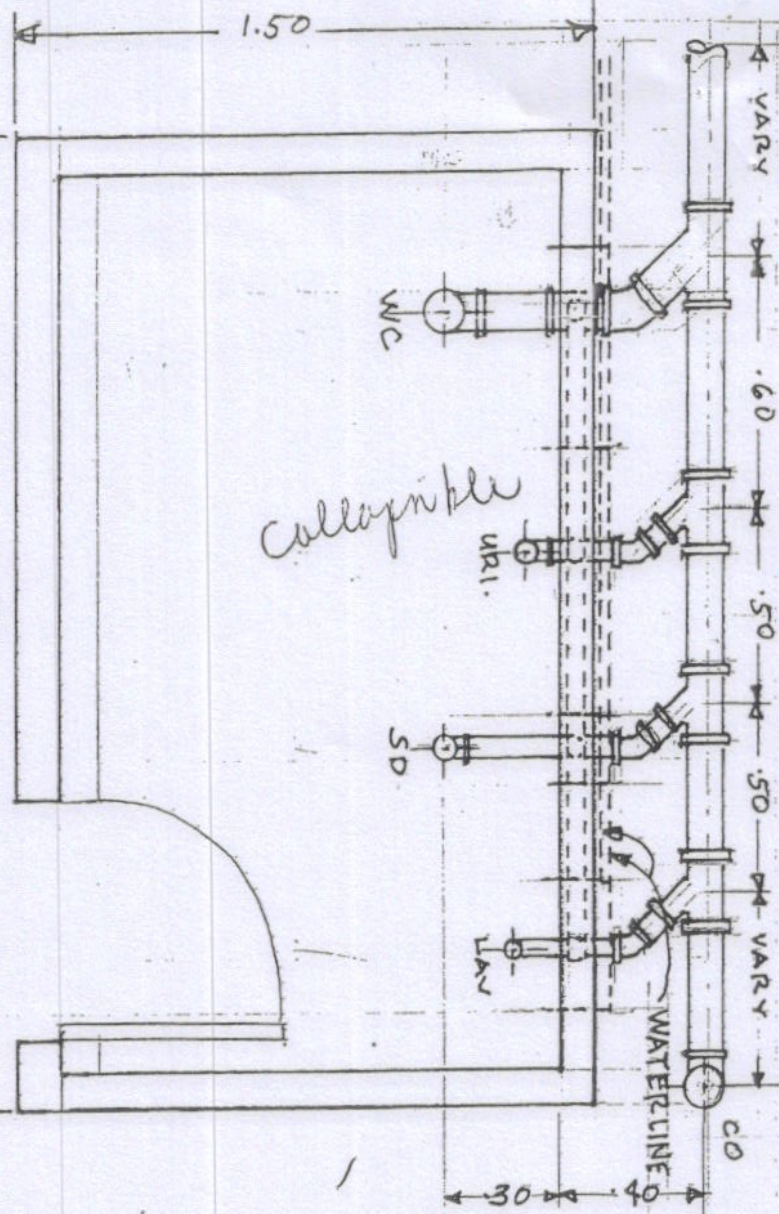
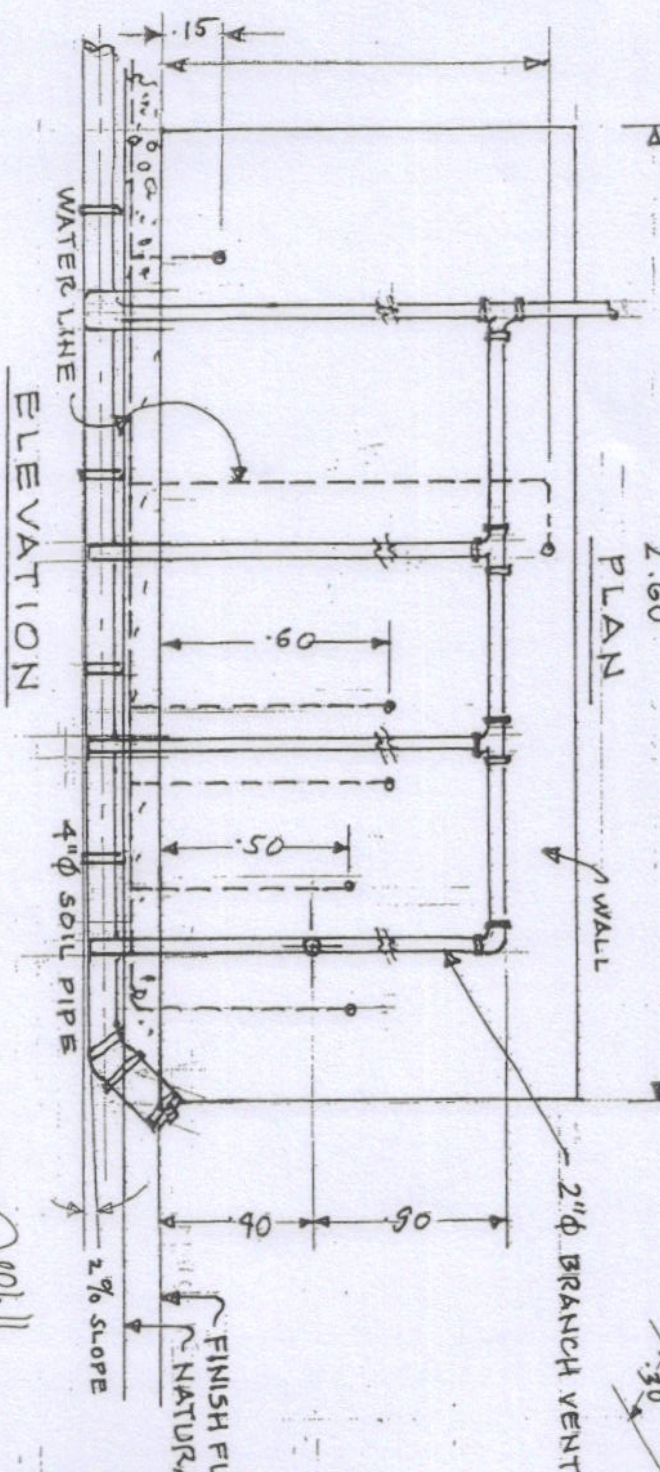

NOTE: ALL MEASUREMENTS
ARE IN CENTIMETERS

Handwritten signature

WASTE LINE
 ISOMETRIC PLUMBING DIAGRAM

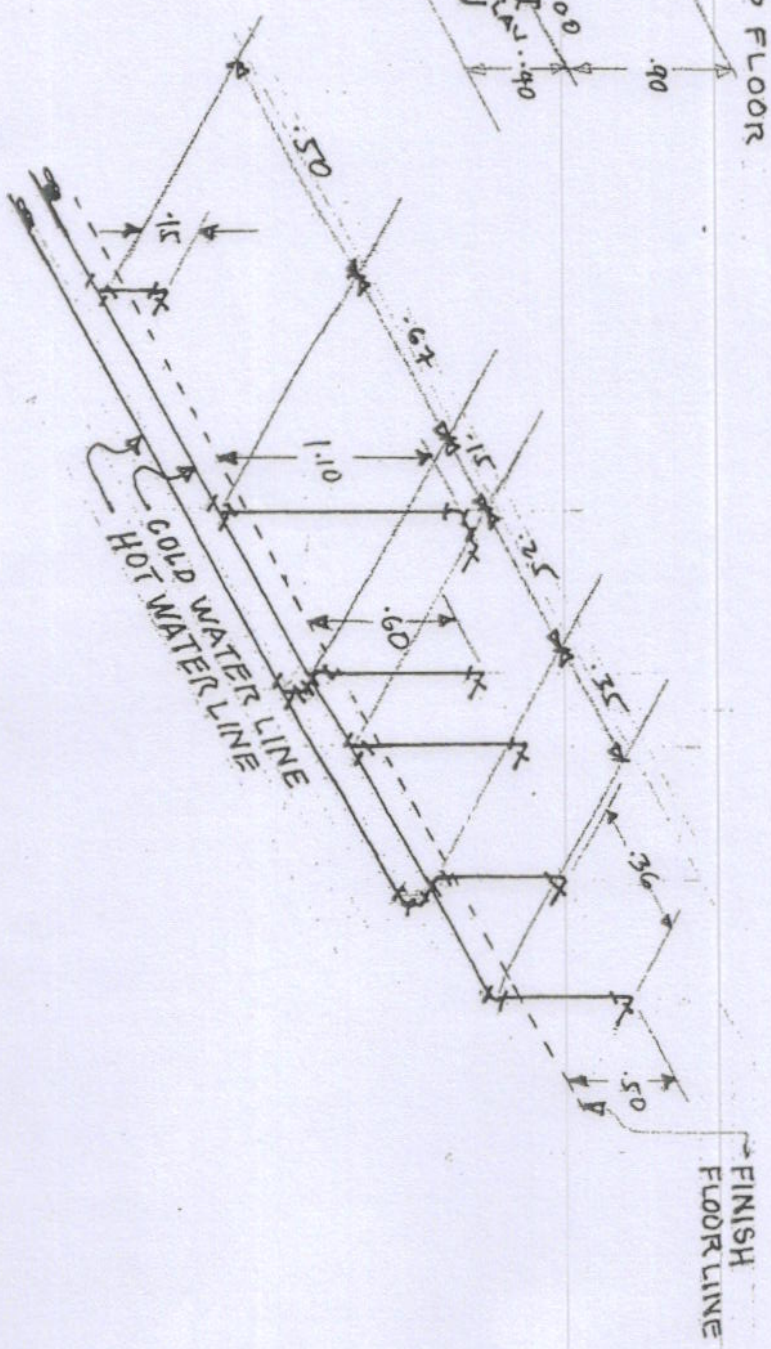
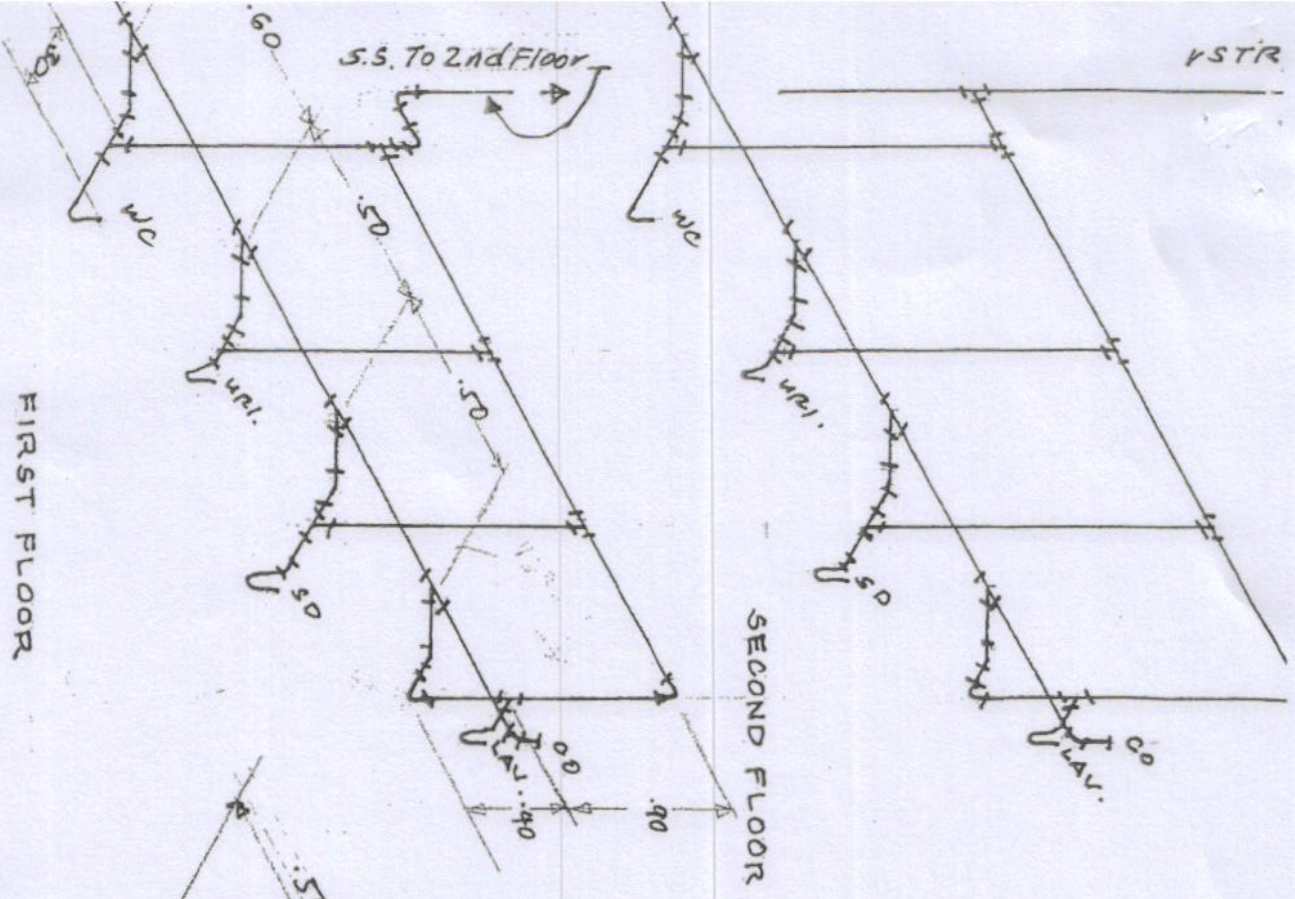

WATER LINE

Handwritten signature

Handwritten initials and date

COMPARATIVE TECHNICAL SPECIFICATION

| Lot. No. 18 - Small Engine Repair Tools and Equipment Mock-up | | TESDA'S SPECIFICATIONS | | BIDDER'S SPECIFICATIONS | |
|---|---|-----------------------------|------------------|-------------------------|--|
| No. | Item | Specifications | Item/Brand/Model | Specifications | |
| 1 | Motorcycle/Small Engine Collapsible Mock-Up | | | | |
| 2 | Auto wire | stranded # 16 | | | |
| 3 | Electrical tape | large black | | | |
| 4 | Head light assembly | 12 volts rectangular | | | |
| 5 | signal light assembly | 12 volts | | | |
| 6 | Horn | 12 volts | | | |
| 7 | Stop light switch | push button | | | |
| 8 | Signal light switch | double throw, toggle switch | | | |
| 9 | Ignition switch | gas engine type | | | |
| 10 | Signal light relay | 12 volts | | | |
| 11 | Push button switch | for horn | | | |
| 12 | Motorcycle storage battery | 12 volts maintenance free | | | |
| 13 | Harness cover | 3/8" diameter (140/4) | | | |
| 14 | Harness connector | 6 terminals | | | |
| 15 | Male terminal | flat | | | |
| 16 | Female terminal | flat | | | |

M7
 pd
 TB

COMPARATIVE TECHNICAL SPECIFICATION

| | | | | |
|----|-----------------------------------|-----------------------------------|--|--|
| 17 | Headlight switch or toggle switch | single throw | | |
| 18 | Crocodile clip | medium, red and black | | |
| 19 | stove bolt | 3/16" diameter X 3/4" , stainless | | |
| 20 | eye terminal | 3/16" diameter hole | | |
| 21 | Four stroke motorcycle engine | 125 or 155cc, surplus | | |

Name of Bidder: _____

Name and Signature of Authorized Representative: _____
 Position/Designation: _____
 Date: _____

9/1/12

Handwritten marks in the top right corner, possibly initials or a signature.

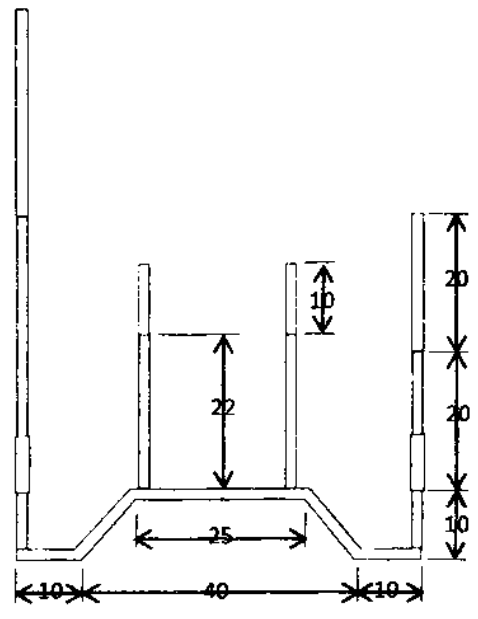
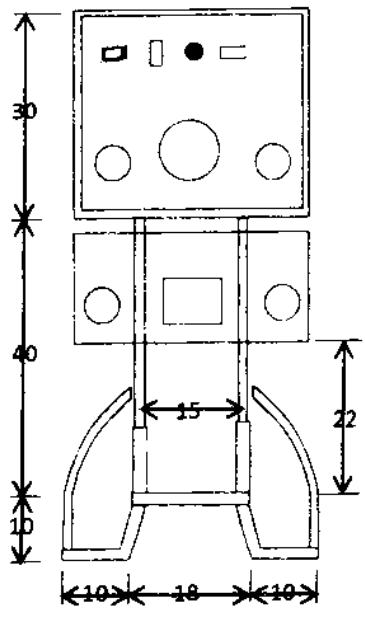
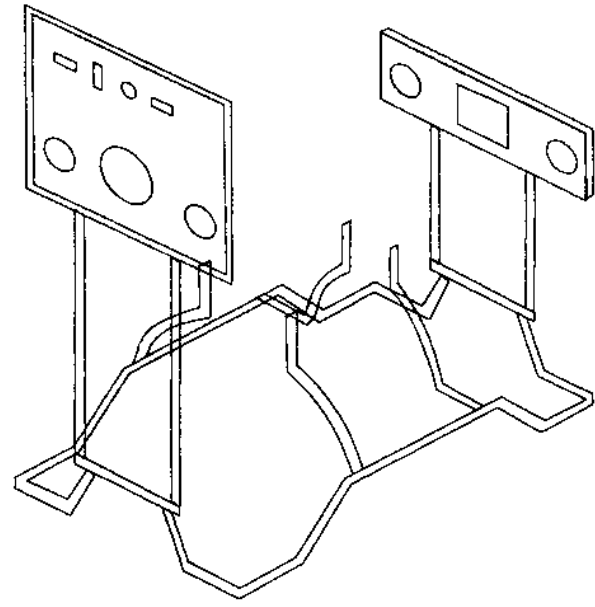
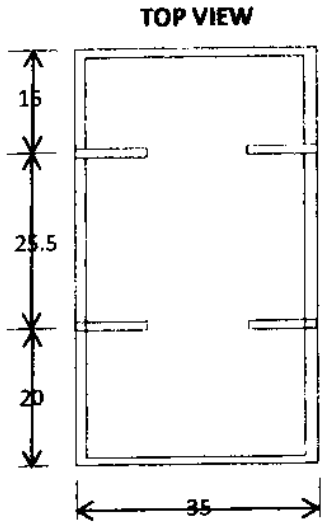

Unit of Measurement = Centimeters
Not Scaled

**MOCK-UP FOR MOTORCYCLE ENGINE
PATTERNED FROM HONDA TMX 155 FRAME**

Handwritten mark at the bottom right corner, possibly initials or a signature.

Handwritten initials and a signature in the top right corner.

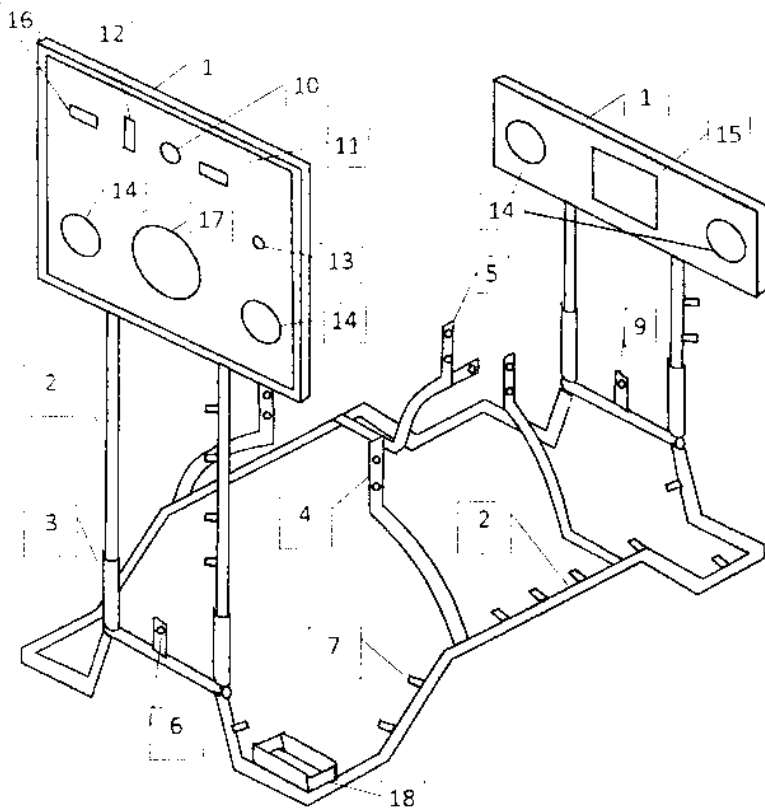

Parts Detail

- 1. G.I. sheet #22
- 2. G.I. pipe 1/2" diameter schedule 40
- 3. G.I. 3/8" diameter schedule 40
- 4. Flat bar, 1/4" x 1 1/4" with 3/8" dia. holes
- 5. Hanger for exhaust pipe
- 6. Provision for stop light switch with 3/8" dia. holes
- 7. Clips for harness 1/8" x 1/4" x 1 1/2", flat bar
- 8. Angle bar, 1/8" x 3/4"
- 9. Provision for horn
- 10. Provision for ignition switch
- 11. Provision for signal light switch
- 12. Provision for dimmer switch
- 13. Provision for signal light relay 3/16" dia.
- 14. Provision for signal light
- 15. Provision for head light
- 16. Provision for head light switch
- 17. Provision for stop light/tail lights
- 18. Provision for battery/ battery holder

BILL OF MATERIALS

- 1 pc 30 cm. x 35 cm. gauge 22, G.I. sheet, for front electrical lighting panel
- 2 pcs 1/8" x 3/4" x 14" } Angle bar, to be assembled into a frame for front
- 2 pcs 1/8" x 3/4" x 12" } electrical lighting panel.
- 1 pc 20 cm. x 35 cm. gauge 22, G. I. sheet, for rear electrical lighting panel.
- 2 pcs 1/8" x 3/4" x 8" } Angle bar, to be assembled into a frame for rear
- 2 pcs 1/8" x 3/4" x 14" } electrical lighting panel.
- 2 pcs 50 cm. x 1/2" dia. G.I. pipe, schedule 40, to support the front electrical lighting panel.
- 2 pcs 30 cm. x 1/2" dia. G.I. pipe, schedule 40, to support the rear electrical lighting panel
- 4 pcs 15 cm. x 3/8" dia. G.I. pipe, schedule 40
- 2 pcs 110 cm. x 1/2" dia. Schedule 40, bent to provide the base support.
- 2 pcs 1/4" x 1 1/4" x 15" with 3/8" holes to mount the front of motorcycle engine support base.
- 2 pcs 1/4" x 1 1/4" x 15" with 3/8" inch holes to mount the rear motorcycle engine support base
- 18 pcs 1/8" x 1/2" x 1 1/2" to serve as clips for harness.
- 2 pcs 3/16" x 1" x 6" angle bar } for battery holder
- 2 pcs 3/16" x 1" x 3" angle bar }
- 2 pcs 5/16" dia. X 4" } machinist's bolt
- 12 pcs 3/8" dia. X 4" }

Equipment

- 1 pc. Four stroke motorcycle engine, 125cc or 155cc

Handwritten signature or initials at the bottom right of the page.

✓
1/2/20
JZGMSAT

Electrical supplies for motorcycle/small engine per mock-up

- 1 roll auto wire, stranded, #16
- 2 pcs electrical tape, large
- 1 pc head light assembly, 12 volts, rectangular
- 2 pairs signal light assembly, 12 volts
- 1 pc tail/stop light assembly, 12 volts
- 1 pc horn, 12 volts
- 1 pc stop light switch,
- 2 pcs signal light switch, double-throw, toggle switch
- 1 pc ignition switch, gas engine type
- 1 pc signal light relay, Bosch/surplus, 12 volts
- 1 pc push button switch for horn
- 1 pc motorcycle storage battery, 12 v., maintenance free
- 4 meters harnesscover, plastic, 3/8" diameter
- 4 pcs harness connector, 6 terminals
- 30 pcs male terminal, flat, utilux
- 30 pcs female terminal, flat, utilux
- 1 pc headlight switch or toggle switch, single-throw

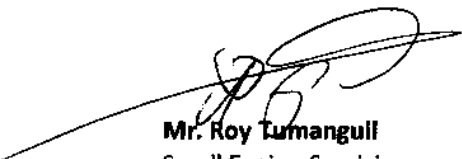

Mr. Roy Tumangull
Small Engine Servicing
JZGMSAT

SUMMARY OF COMPUTATION

Approved Budget for the Contract per Lot

MOBILE TRAINING LABORATORY for Storage Purposes of Tools and Equipment, Multimedia & Accessories and Mock-up

| Lot No. | Box No. | Qty. | Unit | Item / Description | Agency Estimate per Unit/Item | No. of Boxes | Total Agency Estimate | |
|--------------|---------|------|------|--|-------------------------------|--------------|-----------------------|---------------------|
| 1 | 1 | 1 | unit | Common Box for Multimedia Equipment & Accessories and Mock-up | 32,158.99 | 88 | 2,829,991.12 | |
| 2 | 2 | 1 | unit | Appliance Repair NC II with Toolbox | 37,160.54 | 10 | 371,605.40 | |
| 3 | 3 | 1 | unit | Bread and Pastry NC II | 33,495.35 | 9 | 301,458.15 | |
| | 4 | 1 | unit | Bread and Pastry NC II | 33,495.35 | 9 | 301,458.15 | |
| 4 | 5 | 1 | unit | Cookery NC II with Plastic Box | 36,147.23 | 16 | 578,355.68 | |
| 5 | 6 | 1 | unit | Electrical Installation and Maintenance NC II with Toolbox | 37,160.54 | 9 | 334,444.86 | |
| 6 | 7 | 1 | unit | Food Processing NC II with Plastic Box | 35,845.82 | 12 | 430,149.84 | |
| 7 | 8 | 1 | unit | Plumbing NC II | 32,387.08 | 8 | 259,096.64 | |
| 8 | 9 | 1 | unit | Small Engine Repair (Motorcycle/Small Engine Servicing NC II) with Toolbox | 38,431.12 | 10 | 384,311.21 | |
| | 10 | 1 | unit | Small Engine Repair (Motorcycle/Small Engine Servicing NC II) with Toolbox | 36,404.50 | 10 | 364,045.00 | |
| TOTAL | | | | | | | | 6,154,916.05 |

TAN
96
af

MOBILE TRAINING LAB (MTL) TOOLS AND EQUIPMENT
Approved Budget for the Contract per Lot

| Item No. | Qty | Unit | ITEM | AGENCY SPECS | AMOUNT | NO. OF BENEFICIARIES | TOTAL COST |
|---|-----|------|--|---|--------|----------------------|------------|
| Lot No. 9 - Appliance Repair NC II Tools and Equipment (for training purposes) | | | | | | | |
| 1 | 25 | unit | Soldering Iron | dual wattage, 25 watts/ 120watts, 220 volt 80 Hz, with long life tip, "gun type" | | | |
| 2 | 25 | unit | Desoldering Tools | desoldering pump with precision regulated return, replacement tip compact, metal housing | | | |
| 3 | 5 | set | Screw driver assorted (Phillips and slotted) | 12x7x1 Inches, 6 pieces per set, plastic handle | | | |
| 4 | 5 | pc | Long Nose Plier | dyna grip, 152mm/6" inches carbon steel | | | |
| 5 | 5 | pc | Diagonal Cutting Plier | dyna grip, 152mm/6" inches carbon steel | | | |
| 6 | 5 | set | Nut Drivers | rust-resistant, nickel-plated bar, hexagonal shank, includes: 5mm, 6mm, 7mm, 8mm, 9mm, 10mm, 11mm | | | |
| 7 | 5 | set | Wrench, Combination | 6mm,8mm,10mm,11mm,12mm,13mm,14mm,15mm,16mm,17mm,19mm,21mm,22mm, 24 mm, chrome vanadium steel | | | |
| 8 | 10 | pc | Wire Stripper | automatic, cap. 1.5mm to 3.5mm | | | |
| 9 | 5 | pc | Ballpeen hammer | 12 oz., 11 1/2" overall length forged steel construction, hardened and tempered, wooden handle | | | |
| 10 | 5 | pc | Flashlight | LED, 3 volts/6 volts, rechargeable | | | |
| 11 | 5 | pc | Detector Light | test light, 220 volts | | | |
| 12 | 25 | pc | Paint Brush | 4 inches width, wooden handle | | | |
| 13 | 1 | unit | Microwave Oven | power capacity: 220V 1300 watts, interior capacity 20 litres, 8 programmes, defrost option, 26cm diameter rotating turntable, digital | | | |
| 14 | 1 | unit | Washing Machine with dryer | power capacity: 500w, 220V, rust proof body, gear drive system, dolphin drive pulsator, washing capacity (dry weight) 7.5kg, spinning capacity (dry weight) 5.5kg, width should be more than 50 cm and length of not more than 100 cm | | | |
| 15 | 1 | unit | Electric Fan | power capacity: 220V, 100w, 60Hz, 3 speed rotary switch, 18 inch metal blade, round/stable plastic base, thermal fuse protection, adjustable height stand fan | | | |
| 16 | 1 | unit | Electric Rice Cooker | power capacity: 700w, 220V, 60Hz, automatic cooking feature, auto shutoff, glass lid, non-stick coated aluminum pan, includes measuring cup and rice scoop | | | |
| 17 | 1 | unit | Electric Flat Iron | power capacity: 1000w, 220V, 60 Hz, non-stick teflon soleplate, thermal fuse protected, variable temperature control, automatic thermostat Control, pilot lamp indicator | | | |
| 18 | 1 | unit | Coffee Maker | power capacity: 550w, 220V, 60Hz, glass pitcher, anti-drip feature, 6 cup water capacity, water level indicator, swing-out filter basket | | | |

Handwritten initials and signature in the bottom right corner.

| Item No. | Qty | Unit | ITEM | AGENCY SPECS | AMOUNT | NO. OF BENEFICIARIES | TOTAL COST |
|----------|-----|------|----------------|---|--------|----------------------|------------|
| 19 | 1 | unit | Oven Toaster | power capacity: 1000w, 220V, 60Hz, stainless steel, 8 liter capacity, 15 minute timer, slide out chrome crumb rack, includes baking tray | | | |
| 20 | 1 | unit | Blender | 1.5 liter capacity, rated voltage, 230V, 60Hz, power consumption: 300 watts, sharp stainless steel blade, safety lock switch, with plastic stirrer for easy mixing | | | |
| 21 | 25 | unit | Multi Tester | analog, standard size analog multimeter for measuring voltage, current and resistance. An auxiliary connector is also provided for checking transistors. SPECIFICATION: <ul style="list-style-type: none"> •DC Voltage Range: 0 to 1000V in seven ranges •AC Voltage Range: 0 to 1000V in five ranges •DC Current Range: 0 to 250mA in four ranges •Resistance Range: x1 to 200MEG in four ranges •Transistor hFE Range: -0 to 1000 •Transistors Leakage Current (ICEO) Range: -0 to 150mAAF Output Range: -10dB to +22dB | | | |
| 22 | 25 | unit | Multi Tester | Digital Multi meters are standard digital multimeter for measuring voltage, current, and resistance with 3-1/2 digit LCD display. This meter measures only 138mm x 70mm x 32mm and weighs approximately 140 grams, including battery. SPECIFICATION: <ul style="list-style-type: none"> •DC Voltage Range: 200mV to 600V in five ranges (auto ranging) •AC Voltage Range: 2V to 600V in four ranges (auto ranging) •DC Current Range: 200mA to 10A in six ranges •Resistance Range: 200 Ohms to 20M in six ranges Transistor hFE Test Range: 0 to 2000 | | | |
| 23 | 1 | unit | Laptop | 15.6", Core i7, 1.40GHz, wide screen, 1TB hard drive, 8GB DDR3 memory, NVIDIA GTX 670MX graphic processor, 3GB video memory, Gigabit 10/100/1000Mbps IEEE802.11b/g/n Wireless LAN, web camera, HDMI, Bluetooth, USB2.0, USB3.0, with Windows 8 OS, up to 6 hours charge-in-use battery, DVDRW super Multi with 1 year warranty | | | |
| 24 | 1 | unit | MS Office 2013 | Home & Student 1 user | | | |
| 25 | 1 | unit | Projector | LCD Projector Portable, RGB liquid crystal shutter projection system (3LCD), White Light Output 2,600 lumens, Colour Light Output 2,600 lumens, XGA Resolution, lightweight: less than 2 kgs. | | | |
| 26 | 1 | pc | HDMI cable | 3 meters, v1.4A HDMI cable for Projector | | | |
| 27 | 1 | pc | Whiteboard | wooden whiteboard (2' x 3') with frame, 1 meter collapsible high stand | | | |
| 28 | 1 | unit | PA System | 550W Portable with Trolley, with 2 wireless mics, 220V, RCA port, with warranty | | | |
| 29 | 1 | unit | Megaphone | with speak and music switch and volume control, 25w | | | |

7
N 96
af

| Item No. | Qty | Unit | ITEM | AGENCY SPECS | AMOUNT | NO. OF BENEFICIARIES | TOTAL COST |
|--|-----|---------|-----------------------|--|-------------|----------------------|---------------|
| 30 | 1 | package | First Aid Kit | First Aid Kit with the contents: betadine, alcohol, adhesive strips, band-aid, disposable gloves, hypoallergenic medical tape (1.25 cm x 9.1m), conforming bandage (5cm), triangular bandage (110m x 110cm), wound dressing no. 15, swab antiseptic, tweezers metal 8 cm, scissors disposable, safety pins assorted (12 pcs), hot and cold compress pack, first aid quick reference guide. | | | |
| This include tools and equipment required to maintain and repair electronically controlled domestic appliances | | | | | 395,931.426 | 10 | 3,959,314.256 |
| Lot No. 10 - Bread and Pastry NC II Tools and Equipment (for training purposes) | | | | | | | |
| 1 | 12 | pc | Measuring Cup, dry | stainless steel, 4 pcs/set (1c, 1/2c, 1/3c & 1/4c) | | | |
| 2 | 12 | pc | Measuring Cup, liquid | glass graduated, 250 ml capacity | | | |
| 3 | 12 | set | Measuring Spoon | Stainless steel 6 pcs/set(1/8 tsp, 1/4 tsp, 1/2tsp, 1 tsp 1/2 tbsp, 1 tbsp) | | | |
| 4 | 10 | pc | Cake Turn Table | plastic cake turntable with locking switch, rubberized feet, white, 12.6x12.6x3.54 inches (LxWxH) | | | |
| 5 | 25 | set | Decorating Tips | stainless steel, 24-piece cake decorating tip set, package size: 17cm x 12cm x 5cm (6.69 x 4.72 x 1.97inches) | | | |
| 6 | 25 | pc | Rolling Pin | wooden, size 33.5 x 5cm, light weight comfortable grip | | | |
| 7 | 10 | pc | Pie Plate, size 6" | aluminum pie pan, 6" diameter x 5/8 in deep, heavy weight round pan | | | |
| 8 | 10 | pc | Pie Plate, size 8" | pie pan, 8" aluminum deep dish pie pan, standard weight aluminum, 8" top outside diameter | | | |
| 9 | 10 | pc | Pie Plate, size 10" | deep aluminum pie pan, 10" diameter, depth 1-1/4", made of 0.7mm thick satin finished aluminum | | | |
| 10 | 10 | pc | Jelly Roll Pan | aluminum, dimension: 2' x 13 x 8' (HxWxD) | | | |
| 11 | 10 | pc | Cake Spring Form Pan | heavy aluminum spring form pan, heavy duty frame, spring form sides for easy removal, size 9 x 3" | | | |
| 12 | 10 | pc | Pie Cutter | triple riveted pizza cutter, made of stainless steel, rolling wheel slicer, 6" | | | |
| 13 | 25 | pc | Rubber Scraper | rubber head, high heat resistant, flexible, 12", color white | | | |
| 14 | 25 | pc | Spatula | Stainless steel straight blade, 14 inches long with wood handle | | | |
| 15 | 6 | set | Cake Stand with tier | 3 tier cake round acrylic cake stand, 3 plates clear, size: 15cm, 20cm, 25cm, 10 inches gap between each tier | | | |
| 16 | 15 | pc | Saucepan | Stainless steel with cover and handle 28cm | | | |
| 17 | 10 | pc | Ladle | stainless steel, 12 inches, comes with brush finished handle, hole in the handle for easy hanging | | | |
| 18 | 12 | pc | Chef Knife | 8 inch, stainless steel full tang blade with plastic handle | | | |
| 19 | 10 | pc | Chopping Board | 12 x 17 inches, polyethylene, easy grip handle, white color | | | |
| 20 | 6 | pc | Weighing Scale | manual, maximum weight capacity 2kg, graduated by grams, removable and washable tray | | | |

[Handwritten signature]

| Item No. | Qty | Unit | ITEM | AGENCY SPECS | AMOUNT | NO. OF BENEFICIARIES | TOTAL COST |
|----------|-----|------|---------------------|--|--------|----------------------|------------|
| 21 | 10 | pc | Grater | made of nonreactive stainless steel easy grip handle | | | |
| 22 | 25 | pc | Wooden Spoon | wooden turner, size 12 inches | | | |
| 23 | 25 | pc | Piping Bag | 12 inches , light weight, reusable, flexible polyester, coated can be boiled, dishwasher safe | | | |
| 24 | 15 | pc | Mixing Bowl | 12 inches diameter ,8-9 quarts capacity, stainless | | | |
| 25 | 25 | pc | Wire Whisk | 8"/20cm, aluminum, balloon style | | | |
| 26 | 5 | unit | Electric Mixer | 4 qt. stainless steel bowl, 5 speeds & quick burst button, bowl rest TM mixer stabilizer, doubles as a hand mixer, 220V, 290-watts peak power, versatile attachment set includes traditional beaters, whisk and dough hooks, brushed stainless steel | | | |
| 27 | 10 | pc | Dough Cutter | dough scraper 8" wide x 4", high polished stainless steel blade | | | |
| 28 | 1 | unit | Oven (gas) | stainless door, 2 trays oven with tempered glass window,22-25" collapsible stand | | | |
| 29 | 10 | pc | Pastry Brush | pastry/basting brush, natural wood handle brushes, 1.5" size | | | |
| 30 | 10 | pc | Bread Knife | 8", serrated edge stain free high -carbon steel blade texture red polypropylene handle | | | |
| 31 | 10 | pc | Flour Sifter | stainless steel mesh flour sifter strainer,12" | | | |
| 32 | 15 | pc | Baking Sheet | aluminum ,13" x 18" | | | |
| 33 | 25 | pc | Muffin Pans | 12 holes, 3 oz. capacity per holes, aluminum | | | |
| 34 | 4 | pc | Working Table | high quality stainless steel foldable tables dimension: 3ft x 3ft | | | |
| 35 | 2 | pc | Gas Stove with tank | 2 burner, made from stainless top body, automatic ignition, with complete accessories | | | |
| 36 | 1 | pc | Kitchen Sink | Kitchen sink, portable single bowl sink stainless steel, with steel collapsible frame legs, with drain hose, Dimension 50cmx50cmx30cm | | | |
| 37 | 5 | pc | Weighing Scale | digital, 1000g, maximum weight capacity, battery operated (AAA battery) 0.1 g to 1000g , LCD display battery included. | | | |
| 38 | 1 | unit | Laptop | 15.6", Core i7, 1.40GHz, wide screen, 1TB hard drive, 8GB DDR3 memory, NVIDIA GTX 670MX graphic processor, 3GB video memory, Gigabit 10/100/1000Mbps IEEE802.11b/g/n Wireless LAN, web camera, HDMI, Bluetooth, USB2.0, USB3.0, with Windows 8 OS, up to 6 hours charge-in-use battery, DVDRW super Multi with 1 year warranty | | | |
| 39 | 1 | unit | MS Office 2013 | Home & Student 1 user | | | |
| 40 | 1 | unit | Projector | LCD Projector Portable, RGB liquid crystal shutter projection system (3LCD), White Light Output 2,600 lumens, Colour Light Output 2,600 lumens, XGA Resolution, lightweight: less than 2 kgs. | | | |
| 41 | 1 | pc | HDMI cable | 3 meters, v1.4A HDMI cable for Projector | | | |
| 42 | 1 | pc | Whiteboard | wooden whiteboard (2' x 3') with frame, 1 meter collapsible high stand | | | |

N
7
2013
09

| Item No. | Qty | Unit | ITEM | AGENCY SPECS | AMOUNT | NO. OF BENEFICIARIES | TOTAL COST |
|---|-----|---------|--------------------------|--|-------------|----------------------|---------------|
| 43 | 1 | unit | PA System | 550W Portable with Trolley, with 2 wireless mics, 220V, RCA port, with warranty | | | |
| 44 | 1 | unit | Megaphone | with speak and music switch and volume control, 25w | | | |
| 45 | 1 | package | First Aid Kit | First Aid Kit with the contents: betadine, alcohol, adhesive strips, band-aid, disposable gloves, hypoallergenic medical tape (1.25 cm x 9.1m), conforming bandage (5cm), triangular bandage (110m x 110cm), wound dressing no. 15, swab antiseptic, tweezers metal 8 cm, scissors disposable, safety pins assorted (12 pcs), hot and cold compress pack, first aid quick reference guide. | | | |
| This include tools and equipment required in bread making, pastry making, cake making and petits fours making | | | | | 484,823.380 | 9 | 5,408,083.620 |
| Lot No. 11 - Cookery NC II Tools and Equipment (for training purposes) | | | | | | | |
| 1 | 10 | pc | Chef Knife | 8 inch, stainless steel full tang blade with plastic handle | | | |
| 2 | 8 | pc | Boning Knife | 8 inches, stainless steel with sharp cutting edge with plastic handle | | | |
| 3 | 4 | pc | Oyster Knife | 7 inches length (3 inches blade and 4 inches handle), stainless steel blade, with comfortable plastic handle | | | |
| 4 | 2 | pc | Cleaver Knife | 7 inches, stain resistant carbon steel blade | | | |
| 5 | 8 | pc | Tenderizer | with flat and textured side, non slip, 10 inches 25.5 cm, solid aluminum construction | | | |
| 6 | 8 | pc | Skimmer | fine, extra fine mesh, 6 inches diameter, with stainless handle | | | |
| 7 | 8 | pc | Wire Skimmer | small, nickel plated wire oil skimmer, 16 inches long overall, 5 inches diameter bowl | | | |
| 8 | 8 | pc | Skimmer | spider, 5 inches diameter, natural bamboo handle, constructed of durable stainless steel with versatile woven design | | | |
| 9 | 8 | pc | Strainer, small | fine, 6" diameter, with stainless handle | | | |
| 10 | 8 | pc | Siever | small 12" diameter, stainless | | | |
| 11 | 8 | pc | Strainer, medium | medium, fine stainless steel mesh, 9 inches diameter with stainless handle | | | |
| 12 | 8 | pc | Turner | solid, stainless steel, with handy loop for hanging, 12 inches long | | | |
| 13 | 8 | pc | Spatula | Stainless steel straight blade, 14 inches long with wood handle | | | |
| 14 | 8 | pc | Wooden Spatula | large comfortable handle, 12 inches long, wooden | | | |
| 15 | 8 | pc | Piping Bag | 12 inches, light weight, reusable, flexible polyester, coated, can be boiled, dishwasher safe | | | |
| 16 | 8 | set | Pastry Tubes | steel stainless, set of 24 pcs, different/assorted icing nozzles medium size, constructed of 18/8 quality stainless steel, comes in plastic storage box with lid | | | |
| 17 | 3 | pc | Strainer, chinois medium | medium, 8 inches diameter, stainless steel including handle | | | |
| 18 | 2 | pc | Strainer, chinois small | small, 5 inches diameter, stainless steel including handle | | | |

Handwritten signature/initials

| Item No. | Qty | Unit | ITEM | AGENCY SPECS | AMOUNT | NO. OF BENEFICIARIES | TOTAL COST |
|----------|-----|------|------------------------|--|--------|----------------------|------------|
| 19 | 4 | set | Funnel | general purpose, hard plastic, comes in 4 different sizes (small, medium, large, extra large) | | | |
| 20 | 8 | set | Measuring Spoon | Stainless steel 6 pcs/set(1/8 tsp, 1/4 tsp, 1/2tsp, 1 tsp 1/2 tbsp, 1 tbsp) | | | |
| 21 | 8 | pc | Food Tong | 12 inches long, stainless steel, and wide shell head with locking | | | |
| 22 | 8 | pc | Measuring Cup, liquid | glass graduated, 250 ml capacity | | | |
| 23 | 2 | set | Ice Cream Scooper | set of three, stainless steel (2 oz, 4 oz and 6 oz) | | | |
| 24 | 10 | pc | Cheese Cloth | 100% cotton 1 yard | | | |
| 25 | 24 | pc | Serving Spoon | stainless steel, 9 inches long | | | |
| 26 | 4 | pc | Pepper and Salt Mill | 2 in 1, wooden, 8" | | | |
| 27 | 2 | unit | Weighing Scale | analog weighing scale ; maximum weight capacity . 5 kg, graduated by grams , removable and washable tray | | | |
| 28 | 2 | unit | Weighing Scale | digital, 1000g, maximum weight capacity, battery operated (AAA battery) 0.1 g to 1000g , LCD display battery included. | | | |
| 29 | 4 | pc | Apple Corer | corer head comfortable on slip handle, corer head is stainless steel | | | |
| 30 | 8 | pc | Wire Whisk | 8"/20cm, aluminum, balloon style | | | |
| 31 | 8 | pc | Wire Whisk, medium | medium, 10 inches/25 cm, aluminum, balloon style | | | |
| 32 | 2 | pc | Wire Whisk, large | heavy duty, stainless steel, 14 inches, balloon style | | | |
| 33 | 1 | set | Measuring Cup, dry | stainless steel, 4 pcs/set (1c, 1/2c, 1/3c & 1/4c) | | | |
| 34 | 10 | pc | Chopping Board | 12 x17 inches, polyethylene, easy grip handle, white color | | | |
| 35 | 8 | pc | Kitchen Scissors | stainless steel blade, size 2 cm x 12 cm x 27 cm, durable and sturdy handle with comfortable grip | | | |
| 36 | 8 | pc | Soup Ladle | 3 oz capacity, stainless steel, with handle, round bottom | | | |
| 37 | 8 | pc | Soup Ladle | 8 oz capacity, stainless steel handle, round bottom | | | |
| 38 | 3 | pc | Soup Ladle | 8 oz capacity, stainless steel handle, round bottom | | | |
| 39 | 2 | pc | Soup Ladle | 12 oz capacity, stainless handle, round bottom, | | | |
| 40 | 10 | pc | Mixing Bowl | 12 inches diameter, 8-9 quarts capacity , stainless | | | |
| 41 | 8 | pc | Kitchen Spoon | solid, stainless steel handle, comfortable non slip handle, round handle 4.5 x2.5 inches | | | |
| 42 | 8 | pc | Kitchen Spoon | slotted, stainless steel, comfortable non slip handle, round handle 10 x 2.5 inches w/ hole | | | |
| 43 | 8 | pc | Kitchen Fork | 7.5 cm x 4.5 cm x 37 cm or 10.5 inches, stainless steel, with 2 prongs, round handle | | | |
| 44 | 3 | pc | Carving Fork | 10.5 inches, stainless steel, with 2 prongs, round handle | | | |
| 45 | 3 | pc | Pocket Pin Thermometer | analog, temperature range from 0oF to 220 of, dial type | | | |
| 46 | 8 | pc | Peeler | Straight blade type dual stainless steel blade, metal handle 5", 2" handle, 3" blade | | | |

TN

| Item No. | Qty | Unit | ITEM | AGENCY SPECS | AMOUNT | NO. OF BENEFICIARIES | TOTAL COST |
|----------|-----|------|---------------------|--|--------|----------------------|------------|
| 47 | 2 | pc | Stockpot | stainless, 17 quarts capacity (22.7 lit), 12 inches diameter (30.5 cm), depth 31 cm, 4 mm thickness | | | |
| 48 | 2 | pc | Frying pan | pan, large, non stick, 26 cm diameter | | | |
| 49 | 2 | pc | Colander | medium, stainless steel, 8 quarts capacity, with base | | | |
| 50 | 1 | pc | Fish Poacher | medium, 18 inches (L) and 6 inches (w), stainless steel, with handle | | | |
| 51 | 8 | pc | Casserole | small, stainless steel, 20 cm diameter, with cover | | | |
| 52 | 4 | pc | Casserole | medium, stainless steel, 24 cm diameter with cover | | | |
| 53 | 1 | pc | Double Boiler | medium, made from stainless steel, 2 quarts capacity, with lid cover | | | |
| 54 | 4 | pc | Paellara | 40 cm diameter, (50 cm with handle), constructed of carbon steel, riveted secure melt handle, safe for all heating surfaces including induction | | | |
| 55 | 8 | pc | Baking Tray | small, main material is carbon, rectangular, size 14 x 10 inches | | | |
| 56 | 12 | pc | Utility Tray | hard plastic tray, rectangular 14x18 inches | | | |
| 57 | 1 | unit | Fire Extinguisher | cylinder type, multipurpose ABC dry chemical, powder aluminum valve coated, rechargeable, 5 lbs capacity, with pressure gauge that allows for immediate pressure status check, with wall hanger, meets requirements for underwriter laboratory (UJ) | | | |
| 58 | 1 | unit | Blender | 1.5 liter capacity, rated voltage, 230V, 60Hz, power consumption: 300 watts, sharp stainless steel blade, safety lock switch, with plastic stirrer for easy mixing | | | |
| 59 | 1 | pc | Pressure Cooker | aluminum, 2 mm, 6 quarts capacity, pressured handle, central pressure valve with self locking mechanism | | | |
| 60 | 4 | unit | Gas Stove with tank | 2 burner, made from stainless top body, automatic ignition, with complete accessories | | | |
| 61 | 4 | pc | Working Table | high quality stainless steel foldable tables dimension: 3ft x 3ft | | | |
| 62 | 1 | unit | Kitchen Sink | Kitchen sink, portable single bowl sink stainless steel, with steel collapsible frame legs, with drain hose, Dimension 50cmx50cmx30cm | | | |
| 63 | 1 | unit | Laptop | 15.6", Core i7, 1.40GHz, wide screen, 1TB hard drive, 8GB DDR3 memory, NVIDIA GTX 870MX graphic processor, 3GB video memory, Gigabit 10/100/1000Mbps IEEE802.11b/g/n Wireless LAN, web camera, HDMI, Bluetooth, USB2.0, USB3.0, with Windows 8 OS, up to 6 hours charge-in-use battery, DVDRW super Multi with 1 year warranty | | | |
| 64 | 1 | unit | MS Office 2013 | Home & Student 1 user | | | |
| 65 | 1 | unit | Projector | LCD Projector Portable, RGB liquid crystal shutter projection system (3LCD), White Light Output 2,600 lumens, Colour Light Output 2,600 lumens, XGA Resolution, lightweight: less than 2 kgs. | | | |
| 66 | 1 | pc | HDMI cable | 3 meters, v1.4A HDMI cable for Projector | | | |

7/11/16

| Item No. | Qty | Unit | ITEM | AGENCY SPECS | AMOUNT | NO. OF BENEFICIARIES | TOTAL COST |
|---|-----|---------|-----------------------|--|-------------|----------------------|---------------|
| 67 | 1 | pc | Whiteboard | wooden whiteboard (2' x 3') with frame, 1 meter collapsible high stand | | | |
| 68 | 1 | unit | PA System | 550W Portable with Trolley, with 2 wireless mics, 220V, RCA port, with warranty | | | |
| 69 | 1 | unit | Megaphone | with speak and music switch and volume control, 25w | | | |
| 70 | 1 | package | First Aid Kit | First Aid Kit with the contents: betadine, alcohol, adhesive strips, band-aid, disposable gloves, hypoallergenic medical tape (1.25 cm x 9.1m), conforming bandage (5cm), triangular bandage (110m x 110cm), wound dressing no. 15, swab antiseptic, tweezers metal 8 cm, scissors disposable, safety pins assorted (12 pcs), hot and cold compress pack, first aid quick reference guide. | | | |
| This include tools and equipment in preparing and cooking hot meals | | | | | 408,140.436 | 8 | 3,249,123.488 |
| Lot No. 12 - Electrical Installation and Maintenance NC II Tools and Equipment (for training purposes) | | | | | | | |
| 1 | 1 | pc | Spirit Level | high impact plastic; magnetic; 3 vials; Length:24" | | | |
| 2 | 5 | pc | Hacksaw | adjustable hacksaw frame with bi-metal hacksaw blade, 24 TPI, aluminum alloy frame and handle | | | |
| 3 | 2 | pc | Pipe Cutter | max. capacity 1/8-2" for steel or ductile iron pipes with steel handle | | | |
| 4 | 2 | pc | Pipe Reamer | 2" capacity, ratchet type with steel handle, 1/8-2" capacity, suitable for use with power drives | | | |
| 5 | 2 | unit | Pipe Threader | drop head with 3 sets of head and dies, sizes (1/2", 3/4", 1") | | | |
| 6 | 2 | unit | Pipe Bender | manual, 1/2-3/4 inch bending radius, ductile high strength iron | | | |
| 7 | 25 | pc | Electricians Plier | overall length 6, knife length: 5/8", material: carbon steel handle finished: plastic dipped | | | |
| 8 | 25 | pc | Long Nose Plier | dyna grip, 152mm/6" inches carbon steel | | | |
| 9 | 25 | set | Phillips Screw Driver | 1x75, PH 2 x 100, PH 2x125 plastic and rubberized handle chrome vanadium, shank 4" | | | |
| 10 | 25 | set | Flat Screw Driver | 3x75, 5x100, 6x125 plastic and rubberized handle chrome vanadium shank 4" | | | |
| 11 | 5 | set | Wrench, Combination | 6mm,8mm,10mm,11mm,12mm,13mm,14mm,15mm,16mm,17mm,19mm,21mm,22mm, 24 mm, chrome vanadium steel | | | |
| 12 | 10 | pc | Wire Stripper | automatic, cap. 1.5mm to 3.5mm | | | |
| 13 | 25 | pc | Electrician Knife | blade length 3", taper ground cutlery single steel blade, ergonomically designed slip resistant grip | | | |
| 14 | 25 | pc | Tool Holster | leather, 3 pocket & 4 holes with belt | | | |

Y/N 96
08

| Item No. | Qty | Unit | ITEM | AGENCY SPECS | AMOUNT | NO. OF BENEFICIARIES | TOTAL COST |
|----------|-----|------|----------------|--|--------|----------------------|------------|
| 15 | 25 | pc | Pull Push Rule | blade length 6 mtrs, blade width 1", high impact ABS case with durable rubber corrosion resistant tru-zero end | | | |
| 16 | 10 | pc | Claw Hammer | 16 oz., forged steel construction, hardened and tempered steel head, smooth face, wooden handle | | | |
| 17 | 2 | unit | Heat Gun | 1600 watts, 230v,60 Hz, 12.5 amp. dual temperature, with different nozzle | | | |
| 18 | 2 | unit | Power Drill | drilling cap.:10mm, cap. wood: 20mm, wattage 350w, no load speed: 0-2500rpm, weight 1.1 kg., Rev.- for rotation, 3/8"capacity, 220VAC, 60Hz | | | |
| 19 | 5 | unit | Multi-Tester | analog, standard-size analog multimeter for measuring voltage, current, and resistance. An auxiliary connector is also provided for checking transistors. Specifications: •DC Voltage Range: 0 to 1000V in seven ranges •AC Voltage Range: 0 to 1000V in five ranges •DC Current Range: 0 to 250mA in four ranges •Resistance Range: x1 to 20KW in four ranges •Transistor hFE Range: -0 to 1000 •Transistors Leakage Current (ICEO) Range: -0 to 150mAAF Output Range: -10dB to +22dB | | | |
| 20 | 2 | unit | Clamp Ammeter | digital max. AC voltage measurement 600V, max. AC current measurement 400Aac, max. DC voltage measurement 600Vdc, max. resistance measurement 400ohms, battery type AAA, clamp meter type, continuity current, frequency, resistance, voltage, display type LCD, jaw capacity, busbars 10x34mm, safety category voltage, 300V, 600V | | | |
| 21 | 2 | pc | Pipe Vise | capacity 2", material steel, d with swivel base with dual locking nuts, 360 degrees of rotation. | | | |
| 22 | 1 | unit | Laptop | 15.6", Core i7, 1.40GHz, wide screen, 1TB hard drive, 8GB DDR3 memory, NVIDIA GTX 670MX graphic processor, 3GB video memory, Gigabit 10/100/1000Mbps IEEE802.11b/g/n Wireless LAN, web camera, HDMI, Bluetooth, USB2.0, USB3.0, with Windows 8 OS, up to 6 hours charge-in-use battery, DVDRW super Multi with 1 year warranty | | | |
| 23 | 1 | unit | MS Office 2013 | Home & Student 1 user | | | |
| 24 | 1 | unit | Projector | LCD Projector Portable, RGB liquid crystal shutter projection system (3LCD), White Light Output 2,600 lumens, Colour Light Output 2,600 lumens, XGA Resolution, lightweight: less than 2 kgs. | | | |
| 25 | 1 | pc | HDMI cable | 3 meters, v1.4A HDMI cable for Projector | | | |
| 26 | 1 | pc | Whiteboard | wooden whiteboard (2' x 3') with frame, 1 meter collapsible high stand | | | |
| 27 | 1 | unit | PA System | 550W Portable with Trolley, with 2 wireless mics, 220V, RCA port, with warranty | | | |
| 28 | 1 | unit | Megaphone | with speak and music switch and volume control, 25w | | | |

7/10/14
09

| Item No. | Qty | Unit | ITEM | AGENCY SPECS | AMOUNT | NO. OF BENEFICIARIES | TOTAL COST |
|---|-----|---------|-----------------------|--|-------------|----------------------|---------------|
| 29 | 1 | package | First Aid Kit | First Aid Kit with the contents: betadine, alcohol, adhesive strips, band-aid, disposable gloves, hypoallergenic medical tape (1.25 cm x 9.1m), conforming bandage (5cm), triangular bandage (110m x 110cm), wound dressing no. 15, swab antiseptic, tweezers metal 8 cm, scissors disposable, safety pins assorted (12 pcs), hot and cold compress pack, first aid quick reference guide. | | | |
| This include tools and equipment in installing wiring devices for floor and ground fault current interrupting outlets and installing electrical lighting systems on auxilliary outlet and lighting fixtures | | | | | 608,687.855 | 9 | 4,578,180.695 |
| Lot No. 13 - Food Processing Tools and Equipment (for training purposes) | | | | | | | |
| 1 | 5 | unit | Weighing Scale | Manual weighing scale, maximum weight capacity, 5 kg., graduated by grams, removable and washable tray | | | |
| 2 | 5 | unit | Weighing Scale | digital, 1000g, maximum weight capacity, battery operated (AAA battery) 0.1 g to 1000g, LCD display battery included. | | | |
| 3 | 25 | pc | Paring Knives | stainless steel blade, 4 inches | | | |
| 4 | 12 | pc | Peeler | Straight blade type, dual stainless steel blade, metal handle 5", 2" handle, 3" blade | | | |
| 5 | 6 | set | Measuring Spoon | Stainless steel 6 pcs/set (1/8 tsp, 1/4 tsp, 1/2 tsp, 1 tsp 1/2 tbs, 1 tbs) | | | |
| 6 | 6 | set | Measuring Cup, dry | stainless steel, 4 pcs/set (1c, 1/2c, 1/3c & 1/4c) | | | |
| 7 | 6 | pc | Measuring Cup, liquid | glass graduated, 250 ml capacity | | | |
| 8 | 5 | pc | Clocks/Timer | digital, battery operated, with convenient clip, battery included. | | | |
| 9 | 12 | set | Mixing Bowl | 12 inches diameter, 8-9 quarts capacity, stainless | | | |
| 10 | 3 | set | Chopping Board | 12x17 inches, polyethylene, easy grip handle, white color | | | |
| 11 | 5 | pc | Dial Thermometer | stainless steel, 12" stem, stainless clip | | | |
| 12 | 4 | unit | Osterizers | 8 speed with pulse, 500 watts, 220 volts 60 hertz, stainless steel ice crusher blade, 6 cups glass jar capacity, with warranty. | | | |
| 13 | 5 | pc | Jar Lifter | non slip handle, rubberized 5" full expansion | | | |
| 14 | 1 | unit | Food Processors | with exact slice system, 2 in one wide mouth feed tube, with high, low, pulse, off operation, adjustable stainless steel slicing disc and ultra tight seal, 220 volts, 60 hertz, 700 watts | | | |
| 15 | 5 | pc | Wire Baskets | stainless steel, rectangular, with handle, 4" x 17.75" x 14" (HxWxD) | | | |
| 16 | 5 | pc | Casseroles | stainless steel, with cover, 5 quarts capacity, with long handles | | | |
| 17 | 5 | pc | Saucepan | stainless steel, with cover and handle, 26 cm | | | |
| 18 | 15 | pc | Spoon, wooden | wooden turner, size 12 inches | | | |
| 19 | 15 | pc | Spoon, basting | 12" long, 100% solid wood, strong and durable. | | | |

TN H
08

| Item No. | Qty | Unit | ITEM | AGENCY SPECS | AMOUNT | NO. OF BENEFICIARIES | TOTAL COST |
|----------|-----|------|----------------------------|--|--------|----------------------|------------|
| 20 | 4 | pc | Paddle, wooden | solid wood, 24 inches length x 3-1/2 inches width | | | |
| 21 | 14 | pc | Food Tong | 12 inches long, stainless steel, and wide shell head with locking | | | |
| 22 | 12 | pc | Kitchen Scissors | stainless steel blade, size 2 cm x 12 cm x 27 cm, durable and sturdy handle with comfortable grip | | | |
| 23 | 4 | pc | Steamer | 8 quarts base pan doubles as a stock pot, aluminum, with cover, 3 layer, 30 cm | | | |
| 24 | 5 | pc | Fermented Containers (pa#) | hard plastic, with 16 liter capacity, with cover | | | |
| 25 | 20 | pc | Utility Tray | hard plastic tray, rectangular 14x18 inches | | | |
| 26 | 10 | pc | Colander | medium, stainless steel, 8 quarts capacity, with base | | | |
| 27 | 1 | unit | Smoke House | Width - 25" Height - 40" Length - 15", 3 Layers of Pariya inside, 1" for Tray above the Charcoal, 2" for the box of Charcoal, Gauge of Stainless - 1.0 Mirror | | | |
| 28 | 3 | unit | Gas Stove with tank | 2 burner, made from stainless top body, automatic ignition, with complete accessories | | | |
| 29 | 2 | unit | Polytemperature Sealer | 300mm long, 220 volts, 60 Hz, 400W | | | |
| 30 | 2 | pc | Pressure Canner | 25 quarts, stainless steel | | | |
| 31 | 3 | pc | Pressure Cooker | 8 quarts, stainless steel | | | |
| 32 | 1 | unit | Electric Oven | 220 V, 60 Hz., 1000W, 18 L capacity, with warranty | | | |
| 33 | 1 | unit | Meat Grinder | (size in cm) 49 x 23 x 29.5, stainless main materials, 220 volts, 60 Hz., 1/2 HP, with warranty | | | |
| 34 | 4 | pc | Casseroles | stainless steel, 10" diameter, with lid | | | |
| 35 | 4 | pc | Working Table | high quality stainless steel foldable tables dimension: 3ft x 3ft | | | |
| 36 | 10 | pc | Chef Knife | 8 inch, stainless steel full tang blade with plastic handle | | | |
| 37 | 1 | unit | Laptop | 15.6", Core i7, 1.40GHz, wide screen, 1TB hard drive, 8GB DDR3 memory, NVIDIA GTX 670MX graphic processor, 3GB video memory, Gigabit 10/100/1000Mbps IEEE802.11b/g/n Wireless LAN, web camera, HDMI, Bluetooth, USB2.0, USB3.0, with Windows 8 OS, up to 6 hours charge-in-use battery, DVDRW super Multi with 1 year warranty | | | |
| 38 | 1 | unit | MS Office 2013 | Home & Student 1 user | | | |
| 39 | 1 | unit | Projector | LCD Projector Portable, RGB liquid crystal shutter projection system (3LCD), White Light Output 2,600 lumens, Colour Light Output 2,600 lumens, XGA Resolution, lightweight: less than 2 kgs. | | | |
| 40 | 1 | pc | HDMI cable | 3 meters, v1.4A HDMI cable for Projector | | | |
| 41 | 1 | pc | Whiteboard | wooden whiteboard (2' x 3') with frame, 1 meter collapsible high stand | | | |

Handwritten signature/initials

| Item No. | Qty | Unit | ITEM | AGENCY SPECS | AMOUNT | NO. OF BENEFICIARIES | TOTAL COST |
|--|-----|---------|-------------------------------|--|-------------|----------------------|---------------|
| 42 | 1 | unit | PA System | 550W Portable with Trolley, with 2 wireless mics, 220V, RCA port, with warranty | | | |
| 43 | 1 | unit | Megaphone | with speak and music switch and volume control, 25w | | | |
| 44 | 1 | package | First Aid Kit | First Aid Kit with the contents: betadine, alcohol, adhesive strips, band-aid, disposable gloves, hypoallergenic medical tape (1.25 cm x 9.1m), conforming bandage (5cm), triangular bandage (110m x 110cm), wound dressing no. 15, swab antiseptic, tweezers metal 8 cm, scissors disposable, safety pins assorted (12 pcs), hot and cold compress pack, first aid quick reference guide. | | | |
| This include tools and equipment required in preparing process food by salting, curing, smoking, fermentation and pickling and sugar concentration | | | | | 445,929.470 | 8 | 2,675,576.820 |
| Lot No. 14 - Plumbing NC II Tools and Equipment (for training purposes) | | | | | | | |
| 1 | 5 | pc | Pipe Wrench | 12" straight, heavy duty, forged alloy steel 12", pipe capacity 2" or 50mm, weight 1.2 kg, cast-iron housing and I-beam handle with full floating forged hook jaw, featuring self cleaning threads with replaceable hook and heel jaws | | | |
| 2 | 5 | pc | Pipe Wrench | 14" straight, heavy duty, forged alloy steel 12", pipe capacity 2" or 50mm, weight 1.6 kg, cast-iron housing and I-beam handle with full floating forged hook jaw, featuring self cleaning threads with replaceable hook and heel jaws | | | |
| 3 | 10 | pc | Pull Push Rule | blade length 8 mtrs, blade width 1", high impact ABS case with durable rubber corrosion resistant in-zero end | | | |
| 4 | 5 | pc | Hacksaw | adjustable hacksaw frame with bi-metal hacksaw blade, 24 TPI, aluminum alloy frame and handle | | | |
| 5 | 5 | pc | Spirit Level | high impact plastic; magnetic; 3 vials; Length:24" | | | |
| 6 | 5 | pc | Pipe Reamer | 2" capacity, ratchet type with steel handle, 1/8-2" capacity, suitable for use with power drives | | | |
| 7 | 5 | pc | Pipe Cutter | max. capacity 1/8-2" for steel or ductile iron pipes with steel handle | | | |
| 8 | 5 | pc | Adjustable Wrench | alloy steel, 0 - 2" jaw opening, 10" length | | | |
| 9 | 5 | pc | Mechanical Plier | mechanical, plastic dipped insulated handle, 8" length, rust-resistant chrome finish, two position adjustable joint pliers | | | |
| 10 | 2 | pc | Pipe Vise | capacity 2", material steel, d with swivel base with dual locking nuts, 360 degrees of rotation. | | | |
| 11 | 2 | pc | Pipe Threader | drop head with 3 sets of head and dies, sizes (1/2", 3/4", 1") | | | |
| 12 | 3 | pc | Portable Tri-stand Chain Vise | 1/8 to 6 in., rear pipe support, rugged tool tray capacity: 1/8" - 6", leg locking: over center tool tray | | | |
| 13 | 1 | pc | Manual Pressure Test Pump | 6 mpa, 860 pal max. pressure, 12 L. capacity, with brass pump valve | | | |
| 14 | 2 | pc | Socket Fusion Machine | 20 mm - 32 mm cap, 3/4", 1", 1-1/4" and 1-1/2". 220V, 1600w | | | |
| 15 | 5 | pc | Ballpeen hammer | 12 oz., 11 1/2" overall length forged steel construction, hardened and tempered, wooden handle | | | |

TN *[signature]*
[initials]

| Item No. | Qty | Unit | ITEM | AGENCY SPECS | AMOUNT | NO. OF BENEFICIARIES | TOTAL COST |
|----------|-----|------|---------------------------|--|--------|----------------------|------------|
| 16 | 2 | pc | Angle Grinder | 4" diameter, wheel cap, 220V, 60 Hz, single phase, 11,000 rpm, all-ball bearing design and metal gear | | | |
| 17 | 1 | pc | Electric Portable Drill | 1/2" bit jaw capacity, 220V, single phase, variable speed (0-550 rpm), heavy duty, 1/2" drill chuck | | | |
| 18 | 4 | pc | Carpenter Steel Square | high tempered aluminum steel, 2" x 16" x 24", 5-60 and 30-degree angle markings, high tempered aluminum for maximum durability, 1/8-inch graduations for long-term visibility, body: 24 by 2-inches, tongue: 16 by 1-1/2" | | | |
| 19 | 5 | pc | Claw Hammer | 16 oz., forged steel construction, hardened and tempered steel head, smooth face, wooden handle | | | |
| 20 | 10 | pc | Paint Brush | 1/2" round trim brush soft bristle, tin-plated ferrules | | | |
| 21 | 25 | pc | Hand Gloves | 5 finger, poly/cotton blend with a latex coated palm | | | |
| 22 | 25 | pc | Safety Hard Hat | V-rib, yellow ball-cap style hard hat with 6 point ratchet-type headgear, 2 point chin strap and V rib on top, polyethylene material | | | |
| 23 | 25 | pc | Safety Shoes | heavy duty steel toe cap, waterproof, anti static (sizes 40-42) its anti-static and heat resistant (up to 300 degree C/572 degree F) with TPU SAFETY cell construction steel toe cap | | | |
| 24 | 25 | pc | Safety Goggles | clear polycarbonate, woven elastic strap (adjustable) | | | |
| 25 | 1 | pc | Water Meter | multi jet plastic meter, 1/2" NPT, 20 gpm, brass body | | | |
| 26 | 1 | pc | Water Closet | flush type, ceramic, dimension (LxWxH): 684x430x787 mm, flushing action: siphonic, single/dual flush: single flush, flush Volume: 6L, flushing activation: front lever, rough-in: 305mm, discharge: floor cover | | | |
| 27 | 2 | pc | Lavatory with Faucet | center hole, with mixing hot and cold faucet, ceramic, wall hung type, wall hung sink, 4-inch center faucet holes, front overflow, self-draining deck area with contoured back and side splash shields | | | |
| 28 | 1 | pc | Kitchen Sink with Faucet | stainless steel, rust and heat resistant, grade 304, 74 cm x 51.5 cm, 16.2 mm outlet hole | | | |
| 29 | 2 | pc | Single Point Water Heater | 4.5kw, 220V, 60 Hz, 2 psi min water pressure, 55 psi, 2 L/min minimum waterflow, 1/2" BSP | | | |
| 30 | 1 | unit | Laptop | 15.6", Core i7, 1.40GHz, wide screen, 1TB hard drive, 8GB DDR3 memory, NVIDIA GTX 670MX graphic processor, 3GB video memory, Gigabit 10/100/1000Mbps IEEE802.11b/g/n Wireless LAN, web camera, HDMI, Bluetooth, USB2.0, USB3.0, with Windows 8 OS, up to 8 hours charge-in-use battery, DVDRW super Multi with 1 year warranty | | | |
| 31 | 1 | unit | MS Office 2013 | Home & Student 1 user | | | |
| 32 | 1 | unit | Projector | LCD Projector Portable, RGB liquid crystal shutter projection system (3LCD), White Light Output 2,800 lumens, Colour Light Output 2,800 lumens, XGA Resolution, lightweight: less than 2 kgs. | | | |

7/11/14

| Item No. | Qty | Unit | ITEM | AGENCY SPECS | AMOUNT | NO. OF BENEFICIARIES | TOTAL COST |
|---|-----|---------|----------------------------|--|-------------|----------------------|---------------|
| 33 | 1 | pc | HDMI cable | 3 meters, v1.4A HDMI cable for Projector | | | |
| 34 | 1 | pc | Whiteboard | wooden whiteboard (2' x 3') with frame, 1 meter collapsible high stand | | | |
| 35 | 1 | unit | PA System | 550W Portable with Trolley, with 2 wireless mics, 220V, RCA port, with warranty | | | |
| 36 | 1 | unit | Megaphone | with speak and music switch and volume control, 25w | | | |
| 37 | 1 | package | First Aid Kit | First Aid Kit with the contents: betadine, alcohol, adhesive strips, band-aid, disposable gloves, hypoallergenic medical tape (1.25 cm x 9.1m), conforming bandage (5cm), triangular bandage (110m x 110cm), wound dressing no. 15, swab antiseptic, tweezers metal 8 cm, scissors disposable, safety pins assorted (12 pcs), hot and cold compress pack, first aid quick reference guide. | | | |
| This include tools and equipment required in making piping joints and performing single unit plumbing installation and assemblies | | | | | 694,734.373 | 6 | 5,567,874.984 |
| Lot No. 15 - Small Engine Repair (Motorcycle/Small Engine Servicing NC II) | | | | | | | |
| Tools and Equipment (for training purposes) | | | | | | | |
| 1 | 10 | set | Impact Drive Tool | 4pcs, 1/2" Impact Driver Set, heavy duty. | | | |
| 2 | 10 | pc | Multi-Tester | analog, standard-size analog multimeter for measuring voltage, current, and resistance. An auxiliary connector is also provided for checking transistors. Specifications: •DC Voltage Range: 0 to 1000V in seven ranges •AC Voltage Range: 0 to 1000V in five ranges •DC Current Range: 0 to 250mA in four ranges •Resistance Range: x1 to 20KW in four ranges •Transistor hFE Range: -0 to 1000 •Transistors Leakage Current (ICEO) Range: -0 to 150mAAF Output Range: -10dB to +22dB | | | |
| 3 | 10 | pc | Oiler | metal case, 1/2 liter cap | | | |
| 4 | 10 | pc | Steel Brush | wooden handle | | | |
| 5 | 10 | pc | Hacksaw | adjustable hacksaw frame with bi-metal hacksaw blade, 24 TPI, aluminum alloy frame and handle | | | |
| 6 | 10 | pc | Center Punch | high speed steel, 5x125 mm | | | |
| 7 | 10 | pc | Cold Chisel | flat blade, 1" (W), 6" (L), hardened steel | | | |
| 8 | 10 | pc | Fly Wheel/Magneto Puller | universal type, six in one fly wheel/magneto puller | | | |
| 9 | 10 | set | Oil Seal Remover/Installer | pointed tip, hardened steel w/ straight handle, 3 pcs per set | | | |
| 10 | 10 | pc | Piston Ring Compressor | self locking w/ L wrench steel, range 2 1/8" to 5 Inch diameter | | | |
| 11 | 10 | pc | Valve Spring Compressor | spring loaded offset jaw overhead valve spring compressor, steel | | | |
| 12 | 10 | pc | Clutch Assembly Remover | universal compressor clutch hub for removal and installation | | | |
| 13 | 10 | pc | Electricians Plier | overall length 6, knife length: 5/8", material: carbon steel handle finished: plastic dipped | | | |

TW 9/25

| Item No. | Qty | Unit | ITEM | AGENCY SPECS | AMOUNT | NO. OF BENEFICIARIES | TOTAL COST |
|----------|-----|------|------------------------|--|--------|----------------------|------------|
| 14 | 10 | pc | Diagonal Cutting Plier | dyna grip, 152mm/6" inches carbon steel | | | |
| 15 | 10 | pc | Mechanical Plier | 8", insulated handle | | | |
| 16 | 10 | pc | Vise Grippped Plier | 10R straight jaw | | | |
| 17 | 10 | pc | Feeler Gauge | 26 blade feeler gauge set, metric & english marked gauge | | | |
| 18 | 10 | pc | Screwdriver, Flat | 8", magnetic tip, chrome vanadium, plastic handle | | | |
| 19 | 10 | pc | Screwdriver, Philips | 8", magnetic tip, chrome vanadium, plastic handle | | | |
| 20 | 10 | pc | Ballpeen hammer | 12 oz., 11 1/2" overall length forged steel construction, hardened and tempered, wooden handle | | | |
| 21 | 10 | pc | Hammer, Brass/copper | 1 lb., wooden handle | | | |
| 22 | 10 | pc | Hammer, Plastic | 1 lb, wooden handle, plastic tip hammer | | | |
| 23 | 10 | pc | Wrench, Sparkplug | 18x18 mm, hexagonal w/ handle | | | |
| 24 | 10 | set | Wrench, Combination | 6mm,8mm,10mm,11mm,12mm,13mm,14mm,15mm,16mm,17mm,19mm,21mm,22mm, 24 mm, chrome vanadium steel | | | |
| 25 | 10 | set | Wrench, Socket | 6 - 32 mm., black, 1/2" drive | | | |
| 26 | 10 | set | Wrench, T-type | 8, 10, 12, 14 mm | | | |
| 27 | 2 | unit | Hand Tractor Engine | diesel engine, single piston, 4 stroke direct injection, 10-12 hp | | | |
| 28 | 1 | unit | Laptop | 15.6", Core i7, 1.40GHz, wide screen, 1TB hard drive, 8GB DDR3 memory, NVIDIA GTX 670MX graphic processor, 3GB video memory, Gigabit 10/100/1000Mbps IEEE802.11b/g/n Wireless LAN, web camera, HDMI, Bluetooth, USB2.0, USB3.0, with Windows 8 OS, up to 6 hours charge-in-use battery, DVDRW super Multi with 1 year warranty | | | |
| 29 | 1 | unit | MS Office 2013 | Home & Student 1 user | | | |
| 30 | 1 | unit | Projector | LCD Projector Portable, RGB liquid crystal shutter projection system (3LCD), White Light Output 2,600 lumens, Colour Light Output 2,600 lumens, XGA Resolution, lightweight: less than 2 kgs. | | | |
| 31 | 1 | pc | HDMI cable | 3 meters, v1.4A HDMI cable for Projector | | | |
| 32 | 1 | pc | Whiteboard | wooden whiteboard (2' x 3') with frame, 1 meter collapsible high stand | | | |
| 33 | 1 | unit | PA System | 550W Portable with Trolley, with 2 wireless mics, 220V, RCA port, with warranty | | | |
| 34 | 1 | unit | Megaphone | with speak and music switch and volume control, 25w | | | |

TW 96
A

| Item No. | Qty | Unit | ITEM | AGENCY SPECS | AMOUNT | NO. OF BENEFICIARIES | TOTAL COST |
|---|-----|---------|---------------|--|-------------|----------------------|-----------------------|
| 35 | 1 | package | First Aid Kit | First Aid Kit with the contents: betadine, alcohol, adhesive strips, band-aid, disposable gloves, hypoallergenic medical tape (1.25 cm x 9.1m), conforming bandage (5cm), triangular bandage (110m x 110cm), wound dressing no. 15, swab antiseptic, tweezers metal 8 cm, scissors disposable, safety pins assorted (12 pcs), hot and cold compress pack, first aid quick reference guide. | | | |
| This include tools and equipment required in periodic maintenance | | | | | 459,294.978 | 10 | 4,592,949.780 |
| GRAND TOTAL | | | | | | | 30,021,113.643 |

Handwritten signature/initials

**MOBILE TRAINING LAB (MTL) Mock-ups
Approved Budget for the Contract per Lot**

| Lot No. | Qty. | Unit | Item / Description | AMOUNT | NO. OF BENEFICIARIES | TOTAL COST |
|--|--|-------|---|-------------------|----------------------|--------------------|
| Lot. No. 16 - Electrical Installation and Maintenance NC II Mock-up | | | | | | |
| | 1 | lot | Electrical Installation Maintenance (EIM) Mock-Up | | | |
| | | | SUPPLIES AND MATERIALS | | | |
| | 1 | pc | Heat gun, 1200 watts | | | |
| | 20 | pc | PVC adapter with lock nuts | | | |
| | 2 | pc | Circuit breaker, 30A | | | |
| | 2 | meter | 1/2" diameter PVC pipe | | | |
| | 1 | pack | Cable ties, 100 pcs./pack | | | |
| | 5 | pc | Incandescent bulb, 220V, 25W | | | |
| | 5 | pc | One pole switch with plate, flush type | | | |
| | 5 | pc | Three way switch with plate, flush type | | | |
| | 5 | pc | Four way switch with plate, flush type | | | |
| | 5 | pc | Lamp receptacle 4" X 4" surface type | | | |
| | 1 | pc | Photo electrical (photocell) | | | |
| | 5 | pc | Convenience outlet, universal type | | | |
| | 1 | pc | Floor outlet, round type | | | |
| | 1 | pc | Ground fault current interrupter | | | |
| | 1 | pc | Circuit breaker 60A with built in housing | | | |
| | 40 | pc | Terminal block 15A 12 slots | | | |
| | 2 | roll | Automotive Wire #14 AWG (1 solid and 1 stranded) | | | |
| | 150 | pc | Terminal lug, Y type | | | |
| | This include supplies and materials required in the fabrication of mock-up | | | 62,396.779 | 9 | 561,571.011 |
| Lot. No. 17 - Plumbing NC II Mock-up | | | | | | |
| | 1 | lot | Plumbing Mock-up (Labor Cost) | | | |
| | | | SUPPLIES AND MATERIALS | | | |
| | 1 | pc | 4" dia PVC Pipe (Orange) | | | |
| | 1 | pc | 4" dia. PVC Elbow 90 deg. | | | |
| | 1 | pc | 4" dia. PVC Elbow 45 deg. | | | |
| | 1 | pc | 4" dia. PVC Clean Out | | | |
| | 1 | pc | 4" x 3" PVC Wye | | | |
| | 3 | pc | 4" x 2" PVC Wye | | | |
| | 1 | pc | 3" dia. PVC pipe | | | |
| | 1 | pc | 3" PVC Elbow | | | |
| | 1 | pc | 3" PVC Elbow 45 deg. | | | |
| | 1 | pc | 3" x 2" PVC Tee | | | |
| | 1 | pc | 3" x 3" PVC Tee | | | |
| | 2 | pc | 2" dia PVC Pipe | | | |
| | 3 | pc | 2" dia. PVC Elbow 45 deg. | | | |
| | 3 | pc | 2" dia. PVC Elbow 90 deg. | | | |
| | 4 | pc | 2" PVC Tee | | | |
| | 2 | pc | 2" PVC P-trap | | | |
| | 2 | pc | 1/2" dia. PPr pipe | | | |
| | 7 | pc | 1/2" dia. PPr elbow | | | |
| | 4 | pc | 1/2" dia. PPr tee | | | |
| | 6 | pc | 1/2" dia. PPr elbow connector | | | |

98-7
2
9

| Lot No. | Qty. | Unit | Item / Description | AMOUNT | NO. OF BENEFICIARIES | TOTAL COST |
|--|------|-------|--|------------|----------------------|----------------------|
| | 2 | pc | 1/2" dia. PPr male connector | | | |
| | 3 | pc | 1/2" dia. PPr union | | | |
| | 4 | pc | 1/2" dia. PPr coupling | | | |
| | 1 | unit | Urinal 480mm X 730mm X 730mm with complete accessories | | | |
| | 1 | unit | Shower head with complete accessories | | | |
| | 1 | pc | 1/2 x 7/8 flexible hose | | | |
| | 3 | pc | 1/2 x 1/2" angle valve | | | |
| | 1 | pc | 3/4" x 4' x 8' Marine Plywood | | | |
| | 4 | pc | 2" x 2" x 12' Lumber | | | |
| | 10 | pc | Teflon Tape | | | |
| | 3 | pc | Metal hinges 2" X 4", heavy duty | | | |
| This include supplies and materials required in the fabrication of mock-up | | | | 16,674.023 | 8 | 133,392.184 |
| Lot. No. 18 - Small Engine Repair (Motorcycle/Small Engine Servicing NC II) Tools and Equipment Mock-up | | | | | | |
| | 1 | lot | Motorcycle/Small Engine Collapsible Mock-Up | | | |
| | | | SUPPLIES AND MATERIALS: | | | |
| | 1 | roll | Auto wire, stranded # 16 | | | |
| | 2 | pc | Electrical tape, large black | | | |
| | 1 | pc | Head light assembly, 12 volts rectangular | | | |
| | 2 | pair | signal light assembly, 12 volts | | | |
| | 1 | pc | Horn, 12 volts | | | |
| | 1 | pc | Stop light switch, push button | | | |
| | 1 | pc | Signal light switch, double throw, toggle switch | | | |
| | 1 | pc | Ignition switch, gas engine type | | | |
| | 1 | pc | Signal light relay, 12 volts | | | |
| | 1 | pc | Push button switch for horn | | | |
| | 1 | pc | Motorcycle storage battery, 12 volts maintenance free | | | |
| | 4 | meter | Harness cover, 3/8" diameter (140/4) | | | |
| | 4 | pc | Harness connector, 6 terminals | | | |
| | 30 | pc | Male terminal, flat | | | |
| | 30 | pc | Female terminal, flat | | | |
| | 1 | pc | Headlight switch or toggle switch, single throw | | | |
| | 1 | pair | Crocodile clip, medium, red and black | | | |
| | 20 | pc | 3/16" diameter X 3/4" stove bolt, stainless | | | |
| | 10 | pc | 3/16" diameter hole, eye terminal | | | |
| | | | | | | |
| | 1 | unit | Four stroke motorcycle engine, 125 or 155cc, surplus | | | |
| This include supplies and materials required in the fabrication of mock-up | | | | 31,415.116 | 10 | 314,151.160 |
| GRAND TOTAL | | | | | | 1,009,114.355 |

12/16

DETAILED DISTRIBUTION PER PROVINCE

Procurement of Compact Mobile Unit (CMU) Boxes, Tools and Equipment and Mock-ups for the Mobile Training Laboratories (MTLs).

| No. | Province | Qualifications to be Offered | MTL Boxes | | | | | | | | | | TOTAL NO. OF BOXES | | |
|-----|--|---|-----------|-------------------------------------|----------------------------|---------------------------|---------------|---|-----------------------|----------------|---|---|--------------------|----------|-----------|
| | | | Lot 1 | Lot 2 | Lot 3 | | Lot 4 | Lot 5 | Lot 6 | Lot 7 | Lot 8 | | | | |
| | | | Box 1 | Box 2 | Box 3 | Box 4 | Box 5 | Box 6 | Box 7 | Box 8 | Box 9 | Box 10 | | | |
| | | | | Common Box for Multimedia Equipment | Appliance Repair NC II Box | Bread and Pasty NC II Box | Cookery NC II | Electrical Installation and Maintenance (EIM) NC II | Food Processing NC II | Plumbing NC II | Small Engine Repair (Motorcycle/Small Engine Servicing NC II) | Small Engine Repair (Motorcycle/Small Engine Servicing NC II) | | | |
| 1 | TESDA Apayao Provincial Office Pudtol Luna, Apayao | 1 Appliance Repair NC II | | 2 | 1 | | | | | | | | | | 3 |
| | | 2 Bread and Pasty NC II | | 1 | | 1 | 1 | | | | | | | | 3 |
| | | 3 Cookery NC II | | 1 | | | | 2 | | | | | | | 3 |
| | | 4 Electrical Installation and Maintenance (EIM) NC II | | 1 | | | | | 1 | | | | | | 2 |
| | | 5 Plumbing NC II | | 1 | | | | | | | 1 | | | | 3 |
| | | 6 Small Engine Repair (Motorcycle/Small Engine Servicing NC II) | | 1 | | | | | | | | | 1 | 1 | 4 |
| | | Sub total Apayao | | 7 | 1 | 1 | 1 | 2 | 1 | 0 | 1 | 1 | 1 | 1 | 18 |
| 2 | TESDA Masbate Provincial Office Capitol Road, Masbate City | 1 Appliance Repair NC II | | 2 | 1 | | | | | | | | | 3 | |
| | | 2 Bread and Pasty NC II | | 1 | | 1 | 1 | | | | | | | 3 | |
| | | 3 Cookery NC II | | 1 | | | | 2 | | | | | | 3 | |
| | | 4 Electrical Installation and Maintenance (EIM) NC II | | 1 | | | | | 1 | | | | | 2 | |
| | | 5 Food Processing NC II | | 1 | | | | | | 2 | | | | 3 | |
| | | 6 Small Engine Repair (Motorcycle/Small Engine Servicing NC II) | | 1 | | | | | | | | | 1 | 1 | 4 |
| | | Sub total Masbate | | 7 | 1 | 1 | 1 | 2 | 1 | 2 | 0 | 1 | 1 | 1 | 18 |
| 3 | TESDA Eastern Samar Provincial Office Borongon, Eastern Samar | 1 Appliance Repair NC II | | 2 | 1 | | | | | | | | | 3 | |
| | | 2 Bread and Pasty NC II | | 1 | | 1 | 1 | | | | | | | 3 | |
| | | 3 Electrical Installation and Maintenance (EIM) NC II | | 1 | | | | | 1 | | | | | 2 | |
| | | 4 Food Processing NC II | | 1 | | | | | | 2 | | | | 3 | |
| | | 5 Plumbing NC II | | 1 | | | | | | | 1 | | | 3 | |
| | | 6 Small Engine Repair (Motorcycle/Small Engine Servicing NC II) | | 1 | | | | | | | | | 1 | 1 | 4 |
| | | Sub total Eastern Samar | | 7 | 1 | 1 | 1 | 0 | 1 | 2 | 1 | 1 | 1 | 1 | 18 |
| 4 | TESDA Northern Samar Provincial Office UEP Compound, Catarman, Northern Samar | 1 Appliance Repair NC II | | 2 | 1 | | | | | | | | | 3 | |
| | | 2 Bread and Pasty NC II | | 1 | | 1 | 1 | | | | | | | 3 | |
| | | 3 Cookery NC II | | 1 | | | | 2 | | | | | | 3 | |
| | | 4 Electrical Installation and Maintenance (EIM) NC II | | 1 | | | | | 1 | | | | | 2 | |
| | | 5 Food Processing NC II | | 1 | | | | | | 2 | | | | 3 | |
| | | 6 Small Engine Repair (Motorcycle/Small Engine Servicing NC II) | | 1 | | | | | | | | | 1 | 1 | 4 |
| | | Sub total Northern Samar | | 7 | 1 | 1 | 1 | 2 | 1 | 2 | 0 | 1 | 1 | 1 | 18 |
| 5 | TESDA Zamboanga del Norte Provincial Office Olingan, Dipolog City Zamboanga del Norte | 1 Appliance Repair NC II | | 2 | 1 | | | | | | | | | 3 | |
| | | 2 Bread and Pasty NC II | | 1 | | 1 | 1 | | | | | | | 3 | |
| | | 3 Electrical Installation and Maintenance (EIM) NC II | | 1 | | | | | 1 | | | | | 2 | |
| | | 4 Food Processing NC II | | 1 | | | | | | 2 | | | | 3 | |
| | | 5 Plumbing NC II | | 1 | | | | | | | 1 | | | 3 | |
| | | 6 Small Engine Repair (Motorcycle/Small Engine Servicing NC II) | | 1 | | | | | | | | | 1 | 1 | 4 |
| | | Sub total Zamboanga del Norte | | 7 | 1 | 1 | 1 | 0 | 1 | 2 | 1 | 1 | 1 | 1 | 18 |
| 6 | TESDA Camiguin Provincial Office Mabini St. Poblacion Mambajao, Camiguin | 1 Appliance Repair NC II | | 2 | 1 | | | | | | | | | 3 | |
| | | 2 Bread and Pasty NC II | | 1 | | 1 | 1 | | | | | | | 3 | |
| | | 3 Cookery NC II | | 1 | | | | 2 | | | | | | 3 | |
| | | 4 Food Processing NC II | | 1 | | | | | | 2 | | | | 3 | |
| | | 5 Plumbing NC II | | 1 | | | | | | | 1 | | | 3 | |
| | | 6 Small Engine Repair (Motorcycle/Small Engine Servicing NC II) | | 1 | | | | | | | | | 1 | 1 | 4 |
| | | Sub total Camiguin | | 7 | 1 | 1 | 1 | 2 | 0 | 2 | 1 | 1 | 1 | 1 | 19 |

1 N
gr
etc

DETAILED DISTRIBUTION PER PROVINCE
Procurement of Compact Mobile Unit (CMU) Boxes, Tools and Equipment and Mock-ups for the Mobile Training Laboratories (MTLs).

| No. | Province | Qualifications to be Offered | MTL Boxes | | | | | | | | | | TOTAL NO. OF BOXES | | |
|--------------------------|---|---|-----------|-------------------------------------|----------------------------|---------------------------|---------------|---|-----------------------|----------------|---|---|--------------------|---|---|
| | | | Lot 1 | Lot 2 | Lot 3 | | Lot 4 | Lot 5 | Lot 6 | Lot 7 | Lot 8 | | | | |
| | | | Box 1 | Box 2 | Box 3 | Box 4 | Box 5 | Box 6 | Box 7 | Box 8 | Box 9 | Box 10 | | | |
| | | | | Common Box for Multimedia Equipment | Appliance Repair NC II Box | Bread and Pasty NC II Box | Cookery NC II | Electrical Installation and Maintenance (EIM) NC II | Food Processing NC II | Plumbing NC II | Small Engine Repair (Motorcycle/Small Engine Servicing NC II) | Small Engine Repair (Motorcycle/Small Engine Servicing NC II) | | | |
| 7 | TESDA North Cotabato Provincial Office Capitol HI-way, Amas, Kidapawan City | 1 Appliance Repair NC II | 2 | 1 | | | | | | | | | | 3 | |
| | | 2 Cookery NC II | 1 | | | | 2 | | | | | | | 3 | |
| | | 3 Electrical Installation and Maintenance (EIM) NC II | 1 | | | | | | 1 | | | | | | 2 |
| | | 4 Food Processing NC II | 1 | | | | | | | 2 | | | | | 3 |
| | | 5 Plumbing NC II | 1 | | | | | | | | 1 | | | | 3 |
| | | 6 Small Engine Repair (Motorcycle/Small Engine Servicing NC II) | 1 | | | | | | | | | | 1 | 1 | 4 |
| Sub total North Cotabato | | | 7 | 1 | 0 | 0 | 2 | 1 | 2 | 1 | 1 | 1 | 18 | | |
| 8 | TESDA Sarangani Provincial Office Door 6-7, 2nd Floor One Roma Square Aparante Aves., City Heights, General Santos City | 1 Appliance Repair NC II | 2 | 1 | | | | | | | | | | 3 | |
| | | 2 Bread and Pasty NC II | 1 | | 1 | 1 | | | | | | | | 3 | |
| | | 3 Cookery NC II | 1 | | | | 2 | | | | | | | 3 | |
| | | 4 Electrical Installation and Maintenance (EIM) NC II | 1 | | | | | | 1 | | | | | | 2 |
| | | 5 Plumbing NC II | 1 | | | | | | | | 1 | | | | 3 |
| | | 6 Small Engine Repair (Motorcycle/Small Engine Servicing NC II) | 1 | | | | | | | | | | 1 | 1 | 4 |
| Sub total Sarangani | | | 7 | 1 | 1 | 1 | 2 | 1 | 0 | 1 | 1 | 1 | 18 | | |
| 9 | TESDA Lanao Del Sur Provincial Office 3rd Floor, Line Agencies Bldg., New Provincial Capitol, Compound Marawi City | 1 Appliance Repair NC II | 2 | 1 | | | | | | | | | | 3 | |
| | | 2 Bread and Pasty NC II | 1 | | 1 | 1 | | | | | | | | 3 | |
| | | 3 Cookery NC II | 1 | | | | 2 | | | | | | | 3 | |
| | | 4 Electrical Installation and Maintenance (EIM) NC II | 1 | | | | | | 1 | | | | | | 2 |
| | | 5 Plumbing NC II | 1 | | | | | | | | 1 | | | | 3 |
| | | 6 Small Engine Repair (Motorcycle/Small Engine Servicing NC II) | 1 | | | | | | | | | | 1 | 1 | 4 |
| Sub total Lanao del Sur | | | 7 | 1 | 1 | 1 | 2 | 1 | 0 | 1 | 1 | 1 | 18 | | |
| 10 | TESDA Maguindanao 2 Provincial Office Unit 1 2nd Floor, ACB Residences, Notre dame Avenue Cotabato City | 1 Appliance Repair NC II | 2 | 1 | | | | | | | | | | 3 | |
| | | 2 Bread and Pasty NC II | 1 | | 1 | 1 | | | | | | | | 3 | |
| | | 3 Cookery NC II | 1 | | | | 2 | | | | | | | 3 | |
| | | 4 Electrical Installation and Maintenance (EIM) NC II | 1 | | | | | | 1 | | | | | | 2 |
| | | 5 Plumbing NC II | 1 | | | | | | | | 1 | | | | 3 |
| | | 6 Small Engine Repair (Motorcycle/Small Engine Servicing NC II) | 1 | | | | | | | | | | 1 | 1 | 4 |
| Sub total Maguindanao | | | 7 | 1 | 1 | 1 | 2 | 1 | 0 | 1 | 1 | 1 | 18 | | |
| TOTAL | | | 70 | 10 | 9 | 9 | 16 | 9 | 12 | 8 | 10 | 10 | 181 | | |

7/21

Procurement of CMU Boxes, Tools and Equipment and Mock-ups for the Mobile Training Laboratories (MTLs).

**TESDA Apayao Provincial Office
Pudtol Luna, Apayao**

| NO. | ITEM | AGENCY SPECS | QTY | UNIT | No. Of Box |
|---|--|---|-----|------|------------|
| Appliance Repair NC II Tools and Equipment (for training purposes) | | | | | |
| 1 | Soldering Iron | dual wattage, 25 watts/ 120watts, 220 volt 60 Hz, with long life tip, "gun type" | 25 | unit | 3 |
| 2 | Desoldering Tools | desoldering pump with precision regulated return, replacement tip compact, metal housing | 25 | unit | 3 |
| 3 | Screw driver assorted (Phillips and slotted) | 12x7x1 inches, 6 pieces per set, plastic handle | 5 | set | 3 |
| 4 | Long Nose Plier | dyna grip, 152mm/6" inches carbon steel | 5 | pc | 3 |
| 5 | Diagonal Cutting Plier | dyna grip, 152mm/6" inches carbon steel | 5 | pc | 3 |
| 6 | Nut Drivers | rust-resistant, nickel-plated bar, hexagonal shank, includes: 5mm, 6mm, 7mm, 8mm, 9mm, 10mm, 11mm | 5 | set | 3 |
| 7 | Wrench, Combination | 6mm,8mm,10mm,11mm,12mm,13mm,14mm,15mm, 16mm,17mm,19mm, 21mm,22mm, 24 mm, chrome vanadium steel | 5 | set | 3 |
| 8 | Wire Stripper | automatic, cap. 1.5mm to 3.5mm | 10 | pc | 3 |
| 9 | Ballpeen hammer | 12 oz., 11 1/2" overall length forged steel construction, hardened and tempered, wooden handle | 5 | pc | 3 |
| 10 | Flashlight | LED, 3 volts/6 volts, rechargeable | 5 | pc | 3 |
| 11 | Detector Light | test light, 220 volts | 5 | pc | 3 |
| 12 | Paint Brush | 4 inches width, wooden handle | 25 | pc | 3 |
| 13 | Microwave Oven | power capacity: 220V 1300 watts, interior capacity 20 liters, 8 programmes, defrost option, 26cm diameter rotating turntable, digital | 1 | unit | 3 |
| 14 | Washing Machine with dryer | power capacity: 500w, 220V, rust proof body, gear drive system, dolphin drive pulsator, washing capacity (dry weight) 7.5kg, spinning capacity (dry weight) 5.5kg, width should be more than 50 cm and length of not more than 100 cm | 1 | unit | 3 |
| 15 | Electric Fan | power capacity: 220V, 100w, 60Hz, 3 speed rotary switch, 18 inch metal blade, round/stable plastic base, thermal fuse protection, adjustable height stand fan | 1 | unit | 3 |
| 16 | Electric Rice Cooker | power capacity: 700w, 220V, 60Hz, automatic cooking feature, auto shutoff, glass lid, non-stick coated aluminum pan, includes measuring cup and rice scoop | 1 | unit | 3 |

1
N
/

Procurement of CMU Boxes, Tools and Equipment and Mock-ups for the Mobile Training Laboratories (MTLs).

**TESDA Apayao Provincial Office
Pudtol Luna, Apayao**

| NO. | ITEM | AGENCY SPECS | QTY | UNIT | No. Of Box |
|-----|--------------------|---|-----|------|------------|
| 17 | Electric Flat Iron | power capacity:1000w, 220V, 60 Hz, non-stick Teflon soleplate, thermal fuse protected, variable temperature control, automatic thermostal Control, pilot lamp indicator | 1 | unit | 3 |
| 18 | Coffee Maker | power capacity: 550w, 220V, 60Hz, glass pitcher, anti-drip feature, 6 cup water capacity, water level indicator, swing-out filter basket | 1 | unit | 3 |
| 19 | Oven Toaster | power capacity: 1000w, 220V, 60Hz, stainless steel, 8 liter capacity, 15 minute timer, slide out chrome crumb rack, includes baking tray | 1 | unit | 3 |
| 20 | Blender | 1.5 liter capacity, rated voltage, 230V, 60Hz, power consumption: 300 watts, sharp stainless steel blade, safety lock switch, with plastic stirrer for easy mixing | 1 | unit | 3 |
| 21 | Multi Tester | analog, standard size analog multimeter for measuring voltage, current and resistance. An auxiliary connector is also provided for checking transistors. SPECIFICATION: <ul style="list-style-type: none"> •DC Voltage Range: 0 to 1000V in seven ranges •AC Voltage Range: 0 to 1000V in five ranges •DC Current Range: 0 to 250mA in four ranges •Resistance Range: x1 to 200MEG in four ranges •Transistor hFE Range: -0 to 1000 •Transistors Leakage Current (ICEO) Range: -0 to 150mAAF Output Range: -10dB to +22dB | 25 | unit | 3 |
| 22 | Multi Tester | Digital Multi meters are standard digital multimeter for measuring voltage, current, and resistance with 3-1/2 digit LCD display. This meter measures only 138mm x 70mm x 32mm and weighs approximately 140 grams, including battery. SPECIFICATION: <ul style="list-style-type: none"> •DC Voltage Range: 200mV to 600V in five ranges (auto ranging) •AC Voltage Range: 2V to 600V in four ranges (auto ranging) •DC Current Range: 200mA to 10A in six ranges •Resistance Range: 200 Ohms to 20M in six ranges Transistor hFE Test Range: 0 to 2000 | 25 | unit | 3 |
| 23 | Laptop | 15.6", Core i7, 1.40GHz, wide screen, 1TB hard drive, 8GB DDR3 memory, NVIDIA GTX 670MX graphic processor, 3GB video memory, Gigabit 10/100/1000Mbps IEEE802.11b/g/n Wireless LAN, web camera, HDMI, Bluetooth, USB2.0, USB3.0, with Windows 8 OS, up to 6 hours charge-in-use battery, DVDRW super Multi with 1 year warranty | 1 | unit | 3 |
| 24 | MS Office 2013 | Home & Student 1 user | 1 | unit | 3 |

Handwritten signature and initials

Procurement of CMU Boxes, Tools and Equipment and Mock-ups for the Mobile Training Laboratories (MTLs).

**TESDA Apayao Provincial Office
Pudtol Luna, Apayao**

| NO. | ITEM | AGENCY SPECS | QTY | UNIT | No. Of Box |
|---|-----------------------|--|-----|---------|------------|
| 25 | Projector | LCD Projector Portable, RGB liquid crystal shutter projection system (3LCD), White Light Output 2,600 lumens, Colour Light Output 2,600 lumens, XGA Resolution, lightweight: less than 2 kgs. | 1 | unit | 3 |
| 26 | HDMI cable | 3 meters, v1.4A HDMI cable for Projector | 1 | pc | 3 |
| 27 | Whiteboard | wooden whiteboard (2' x 3') with frame, 1 meter collapsible high stand | 1 | pc | 3 |
| 28 | PA System | 550W Portable with Trolley, with 2 wireless mics, 220V, RCA port, with warranty | 1 | unit | 3 |
| 29 | Megaphone | with speak and music switch and volume control, 25w | 1 | unit | 3 |
| 30 | First Aid Kit | First Aid Kit with the contents: betadine, alcohol, adhesive strips, band-aid, disposable gloves, hypoallergenic medical tape (1.25 cm x 9.1m), conforming bandage (5cm), triangular bandage (110m x 110cm), wound dressing no. 15, swab antiseptic, tweezers metal 8 cm, scissors disposable, safety pins assorted (12 pcs), hot and cold compress pack, first aid quick reference guide. | 1 | package | 3 |
| Bread and Pastry NC II Tools and Equipment (for training purposes) | | | | | |
| 1 | Measuring Cup, dry | stainless steel, 4 pcs/set (1c, 1/2c, 1/3c & 1/4c) | 12 | pc | 3 |
| 2 | Measuring Cup, liquid | glass graduated, 250 ml capacity | 12 | pc | 3 |
| 3 | Measuring Spoon | Stainless steel 6 pcs/set(1/8 tsp, 1/4 tsp, 1/2tsp, 1 tsp 1/2 tbsp, 1 tbsp) | 12 | set | 3 |
| 4 | Cake Turn Table | plastic cake turntable with locking switch, rubberized feet, white, 12.6x12.6x3.54 inches (LxWxH) | 10 | pc | 3 |
| 5 | Decorating Tips | stainless steel, 24-piece cake decorating tip set, package size: 17cm x 12cm x 5cm (6.69 x 4.72 x 1.97inches) | 25 | set | 3 |
| 6 | Rolling Pin | wooden, size 33.5 x 5cm, light weight comfortable grip | 25 | pc | 3 |
| 7 | Pie Plate, size 6" | aluminum pie pan, 6" diameter x 5/8 in deep, heavy weight round pan | 10 | pc | 3 |
| 8 | Pie Plate, size 8" | pie pan, 8" aluminum deep dish pie pan, standard weight aluminum, 8" top outside diameter | 10 | pc | 3 |
| 9 | Pie Plate, size 10" | deep aluminum pie pan, 10" diameter, depth 1-1/4", made of 0.7mm thick satin finished aluminum | 10 | pc | 3 |
| 10 | Jelly Roll Pan | aluminum, dimension: 2" x 13 x 8" (HxWxD) | 10 | pc | 3 |
| 11 | Cake Spring Form Pan | heavy aluminum spring form pan, heavy duty frame, spring form sides for easy removal, size 9 x 3" | 10 | pc | 3 |

Procurement of CMU Boxes, Tools and Equipment and Mock-ups for the Mobile Training Laboratories (MTLs).

**TESDA Apayao Provincial Office
Pudtol Luna, Apayao**

| NO. | ITEM | AGENCY SPECS | QTY | UNIT | No. Of Box |
|-----|----------------------|--|-----|------|------------|
| 12 | Pie Cutter | triple riveted pizza cutter, made of stainless steel, rolling wheel slicer, 6" | 10 | pc | 3 |
| 13 | Rubber Scraper | rubber head, high heat resistant, flexible, 12", color white | 25 | pc | 3 |
| 14 | Spatula | Stainless steel straight blade, 14 inches long with wood handle | 25 | pc | 3 |
| 15 | Cake Stand with tier | 3 tier cake round acrylic cake stand, 3 plates clear, size: 15cm, 20cm, 25cm, 10 inches gap between each tier | 6 | set | 3 |
| 16 | Saucepan | Stainless steel with cover and handle 26cm | 15 | pc | 3 |
| 17 | Ladle | stainless steel, 12 inches, comes with brush finished handle, hole in the handle for easy hanging | 10 | pc | 3 |
| 18 | Chef Knife | 8 inch, stainless steel full tang blade with plastic handle | 12 | pc | 3 |
| 19 | Chopping Board | 12 x 17 inches, polyethylene, easy grip handle, white color | 10 | pc | 3 |
| 20 | Weighing Scale | manual, maximum weight capacity 2kg, graduated by grams, removable and washable tray | 6 | pc | 3 |
| 21 | Grater | made of nonreactive stainless steel easy grip handle | 10 | pc | 3 |
| 22 | Wooden Spoon | wooden turner, size 12 inches | 25 | pc | 3 |
| 23 | Piping Bag | 12 inches, light weight, reusable, flexible polyester, coated can be boiled, dishwasher safe | 25 | pc | 3 |
| 24 | Mixing Bowl | 12 inches diameter, 8-9 quarts capacity, stainless | 15 | pc | 3 |
| 25 | Wire Whisk | 8"/20cm, aluminum, balloon style | 25 | pc | 3 |
| 26 | Electric Mixer | 4 qt. stainless steel bowl, 5 speeds & quick burst button, bowl rest TM mixer stabilizer, doubles as a hand mixer, 220V, 290-watts peak power, versatile attachment set includes traditional beaters, whisk and dough hooks, brushed stainless steel | 5 | unit | 3 |
| 27 | Dough Cutter | dough scraper 6" wide x 4", high polished stainless steel blade | 10 | pc | 3 |
| 28 | Oven (gas) | stainless door, 2 trays oven with tempered glass window, 22-25" collapsible stand | 1 | unit | 3 |
| 29 | Pastry Brush | pastry/basting brush, natural wood handle brushes, 1.5" size | 10 | pc | 3 |
| 30 | Bread Knife | 8", serrated edge stain free high-carbon steel blade texture red polypropylene handle | 10 | pc | 3 |
| 31 | Flour Sifter | stainless steel mesh flour sifter strainer, 12" | 10 | pc | 3 |
| 32 | Baking Sheet | aluminum, 13" x 18" | 15 | pc | 3 |
| 33 | Muffin Pans | 12 holes, 3 oz. capacity per holes, aluminum | 25 | pc | 3 |

Procurement of CMU Boxes, Tools and Equipment and Mock-ups for the Mobile Training Laboratories (MTLs).

**TESDA Apayao Provincial Office
Pudtol Luna, Apayao**

| NO. | ITEM | AGENCY SPECS | QTY | UNIT | No. Of Box |
|--|---------------------|--|-----|---------|------------|
| 34 | Working Table | high quality stainless steel foldable tables dimension: 3ft x 3ft | 4 | pc | 3 |
| 35 | Gas Stove with tank | 2 burner, made from stainless top body, automatic ignition, with complete accessories | 2 | pc | 3 |
| 36 | Kitchen Sink | Kitchen sink, portable single bowl sink stainless steel, with steel collapsible frame legs, with drain hose, Dimension 50cmx50cmx30cm | 1 | pc | 3 |
| 37 | Weighing Scale | digital, 1000g, maximum weight capacity, battery operated (AAA battery) 0.1 g to 1000g , LCD display battery included. | 5 | pc | 3 |
| 38 | Laptop | 15.6", Core i7, 1.40GHz, wide screen, 1TB hard drive, 8GB DDR3 memory, NVIDIA GTX 670MX graphic processor, 3GB video memory, Gigabit 10/100/1000Mbps IEEE802.11b/g/n Wireless LAN, web camera, HDMI, Bluetooth, USB2.0, USB3.0, with Windows 8 OS, up to 6 hours charge-in-use battery, DVDRW super Multi with 1 year warranty | 1 | unit | 3 |
| 39 | MS Office 2013 | Home & Student 1 user | 1 | unit | 3 |
| 40 | Projector | LCD Projector Portable, RGB liquid crystal shutter projection system (3LCD), White Light Output 2,600 lumens, Colour Light Output 2,600 lumens, XGA Resolution, lightweight: less than 2 kgs. | 1 | unit | 3 |
| 41 | HDMI cable | 3 meters, v1.4A HDMI cable for Projector | 1 | pc | 3 |
| 42 | Whiteboard | wooden whiteboard (2' x 3') with frame, 1 meter collapsible high stand | 1 | pc | 3 |
| 43 | PA System | 550W Portable with Trolley, with 2 wireless mics, 220V, RCA port, with warranty | 1 | unit | 3 |
| 44 | Megaphone | with speak and music switch and volume control, 25w | 1 | unit | 3 |
| 45 | First Aid Kit | First Aid Kit with the contents: betadine, alcohol, adhesive strips, band-aid, disposable gloves, hypoallergenic medical tape (1.25 cm x 9.1m), conforming bandage (5cm), triangular bandage (110m x 110cm), wound dressing no. 15, swab antiseptic, tweezers metal 8 cm, scissors disposable, safety pins assorted (12 pcs), hot and cold compress pack, first aid quick reference guide. | 1 | package | 3 |
| Cookery NC II Tools and Equipment (for training purposes) | | | | | |
| 1 | Chef Knife | 8 inch, stainless steel full tang blade with plastic handle | 10 | pc | 3 |
| 2 | Boning Knife | 6 inches, stainless steel with sharp cutting edge with plastic handle | 8 | pc | 3 |
| 3 | Oyster Knife | 7 inches length (3 inches blade and 4 inches handle), stainless steel blade, with comfortable plastic handle | 4 | pc | 3 |

1

Procurement of CMU Boxes, Tools and Equipment and Mock-ups for the Mobile Training Laboratories (MTLs).

**TESDA Apayao Provincial Office
Pudtol Luna, Apayao**

| NO. | ITEM | AGENCY SPECS | QTY | UNIT | No. Of Box |
|-----|--------------------------|--|-----|------|------------|
| 4 | Cleaver Knife | 7 inches, stain resistant carbon steel blade | 2 | pc | 3 |
| 5 | Tenderizer | with flat and textured side, non slip, 10 inches 25.5 cm, solid aluminum construction | 8 | pc | 3 |
| 6 | Skimmer | fine, extra fine mesh, 6 inches diameter, with stainless handle | 8 | pc | 3 |
| 7 | Wire Skimmer | small, nickel plated wire oil skimmer, 16 inches long overall, 5 inches diameter bowl | 8 | pc | 3 |
| 8 | Skimmer | spider, 5 inches diameter, natural bamboo handle, constructed of durable stainless steel with versatile woven design | 8 | pc | 3 |
| 9 | Strainer, small | fine, 6" diameter, with stainless handle | 8 | pc | 3 |
| 10 | Siever | small 12" diameter, stainless | 8 | pc | 3 |
| 11 | Strainer, medium | medium, fine stainless steel mesh, 9 inches diameter with stainless handle | 8 | pc | 3 |
| 12 | Turner | solid, stainless steel, with handy loop for hanging, 12 inches long | 8 | pc | 3 |
| 13 | Spatula | Stainless steel straight blade, 14 inches long with wood handle | 8 | pc | 3 |
| 14 | Wooden Spatula | large comfortable handle, 12 inches long, wooden | 8 | pc | 3 |
| 15 | Piping Bag | 12 inches, light weight, reusable, flexible polyester, coated, can be boiled, dishwasher safe | 8 | pc | 3 |
| 16 | Pastry Tubes | steel stainless, set of 24 pcs, different/assorted icing nozzles medium size, constructed of 18/8 quality stainless steel, comes in plastic storage box with lid | 8 | set | 3 |
| 17 | Strainer, chinois medium | medium, 8 inches diameter, stainless steel including handle | 3 | pc | 3 |
| 18 | Strainer, chinois small | small, 5 inches diameter, stainless steel including handle | 2 | pc | 3 |
| 19 | Funnel | general purpose, hard plastic, comes in 4 different sizes (small, medium, large, extra large) | 4 | set | 3 |
| 20 | Measuring Spoon | Stainless steel 6 pcs/set (1/8 tsp, 1/4 tsp, 1/2 tsp, 1 tsp, 1/2 tbsp, 1 tbsp) | 6 | set | 3 |
| 21 | Food Tong | 12 inches long, stainless steel, and wide shell head with locking | 8 | pc | 3 |
| 22 | Measuring Cup, liquid | glass graduated, 250 ml capacity | 8 | pc | 3 |
| 23 | Ice Cream Scooper | set of three, stainless steel (2 oz, 4 oz and 6 oz) | 2 | set | 3 |
| 24 | Cheese Cloth | 100% cotton 1 yard | 10 | pc | 3 |
| 25 | Serving Spoon | stainless steel, 9 inches long | 24 | pc | 3 |
| 26 | Pepper and Salt Mill | 2 in 1, wooden, 8" | 4 | pc | 3 |

7
N
af go

Procurement of CMU Boxes, Tools and Equipment and Mock-ups for the Mobile Training Laboratories (MTLs).

**TESDA Apayao Provincial Office
Pudtol Luna, Apayao**

| NO. | ITEM | AGENCY SPECS | QTY | UNIT | No. Of Box |
|-----|------------------------|--|-----|------|------------|
| 27 | Weighing Scale | analog weighing scale ; maximum weight capacity , 5 kg, graduated by grams , removable and washable tray | 2 | unit | 3 |
| 28 | Weighing Scale | digital, 1000g, maximum weight capacity, battery operated (AAA battery) 0.1 g to 1000g , LCD display battery included. | 2 | unit | 3 |
| 29 | Apple Corer | corer head comfortable on slip handle, corer head is stainless steel | 4 | pc | 3 |
| 30 | Wire Whisk | 8"/20cm, aluminum, balloon style | 8 | pc | 3 |
| 31 | Wire Whisk, medium | medium, 10 inches/25 cm, aluminum, balloon style | 8 | pc | 3 |
| 32 | Wire Whisk, large | heavy duty, stainless steel, 14 inches, balloon style | 2 | pc | 3 |
| 33 | Measuring Cup, dry | stainless steel, 4 pcs/set (1c , 1/2c, 1/3c & 1/4c) | 1 | set | 3 |
| 34 | Chopping Board | 12 x17 inches, polyethylene, easy grip handle, white color | 10 | pc | 3 |
| 35 | Kitchen Scissors | stainless steel blade, size 2 cm x 12 cm x 27 cm, durable and sturdy handle with comfortable grip | 8 | pc | 3 |
| 36 | Soup Ladle | 3 oz capacity, stainless steel, with handle, round bottom | 8 | pc | 3 |
| 37 | Soup Ladle | 6 oz capacity, stainless steel handle, round bottom | 8 | pc | 3 |
| 38 | Soup Ladle | 8 oz capacity, stainless steel handle, round bottom | 3 | pc | 3 |
| 39 | Soup Ladle | 12 oz capacity, stainless handle, round bottom, | 2 | pc | 3 |
| 40 | Mixing Bowl | 12 inches diameter, 8-9 quarts capacity , stainless | 10 | pc | 3 |
| 41 | Kitchen Spoon | solid, stainless steel handle, comfortable non slip handle, round handle 4.5 x2.5 inches | 8 | pc | 3 |
| 42 | Kitchen Spoon | stotted, stainless steel, comfortable non slip handle, round handle 10 x 2.5 inches w/ hole | 8 | pc | 3 |
| 43 | Kitchen Fork | 7.5 cm x 4.5 cm x 37 cm or 10.5 inches, stainless steel, with 2 prongs, round handle | 8 | pc | 3 |
| 44 | Carving Fork | 10.5 inches, stainless steel, with 2 prongs, round handle | 3 | pc | 3 |
| 45 | Pocket Pin Thermometer | analog, temperature range from 0oF to 220 of, dial type | 3 | pc | 3 |
| 46 | Peeler | Straight blade type, dual stainless steel blade, metal handle 5",2"handle,3"blade | 8 | pc | 3 |
| 47 | Stockpot | stainless, 17 quarts capacity (22.7 lit), 12 inches diameter (30.5 cm), depth 31 cm, 4 mm thickness | 2 | pc | 3 |
| 48 | Frying pan | pan, large, non stick, 26 cm diameter | 2 | pc | 3 |

Handwritten signature and initials

Procurement of CMU Boxes, Tools and Equipment and Mock-ups for the Mobile Training Laboratories (MTLs).

**TESDA Apayao Provincial Office
Pudtol Luna, Apayao**

| NO. | ITEM | AGENCY SPECS | QTY | UNIT | No. Of Box |
|-----|---------------------|--|-----|------|------------|
| 49 | Colander | medium, stainless steel, 8 quarts capacity, with base | 2 | pc | 3 |
| 50 | Fish Poacher | medium, 18 inches (L) and 6 inches (w), stainless steel, with handle | 1 | pc | 3 |
| 51 | Casserole | small, stainless steel, 20 cm diameter, with cover | 8 | pc | 3 |
| 52 | Casserole | medium, stainless steel, 24 cm diameter with cover | 4 | pc | 3 |
| 53 | Double Boiler | medium, made from stainless steel, 2 quarts capacity, with lid cover | 1 | pc | 3 |
| 54 | Paellara | 40 cm diameter, (50 cm with handle), constructed of carbon steel, riveted secure melt handle, safe for all heating surfaces including induction | 4 | pc | 3 |
| 55 | Baking Tray | small, main material is carbon, rectangular, size 14 x 10 inches | 8 | pc | 3 |
| 56 | Utility Tray | hard plastic tray, rectangular 14x18 inches | 12 | pc | 3 |
| 57 | Fire Extinguisher | cylinder type, multipurpose ABC dry chemical, powder aluminum valve coated, rechargeable, 5 lbs capacity, with pressure gauge that allows for immediate pressure status check, with wall hanger, meets requirements for underwriter laboratory (UJ) | 1 | unit | 3 |
| 58 | Blender | 1.5 liter capacity, rated voltage, 230V, 60Hz, power consumption: 300 watts, sharp stainless steel blade, safety lock switch, with plastic stirrer for easy mixing | 1 | unit | 3 |
| 59 | Pressure Cooker | aluminum, 2 mm, 6 quarts capacity, pressured handle, central pressure valve with self locking mechanism | 1 | pc | 3 |
| 60 | Gas Stove with tank | 2 burner, made from stainless top body, automatic ignition, with complete accessories | 4 | unit | 3 |
| 61 | Working Table | high quality stainless steel foldable tables dimension: 3ft x 3ft | 4 | pc | 3 |
| 62 | Kitchen Sink | Kitchen sink, portable single bowl sink stainless steel, with steel collapsible frame legs, with drain hose, Dimension 50cmx50cmx30cm | 1 | unit | 3 |
| 63 | Laptop | 15.6", Core i7, 1.40GHz, wide screen, 1TB hard drive, 8GB DDR3 memory, NVIDIA GTX 670MX graphic processor, 3GB video memory, Gigabit 10/100/1000Mbps IEEE802.11b/g/n Wireless LAN, web camera, HDMI, Bluetooth, USB2.0, USB3.0, with Windows 8 OS, up to 6 hours charge-in-use battery, DVDRW super Multi with 1 year warranty | 1 | unit | 3 |
| 64 | MS Office 2013 | Home & Student 1 user | 1 | unit | 3 |
| 65 | Projector | LCD Projector Portable, RGB liquid crystal shutter projection system (3LCD), White Light Output 2,600 lumens, Colour Light Output 2,600 lumens, XGA Resolution, lightweight: less than 2 kgs. | 1 | unit | 3 |

7
N
W

Procurement of CMU Boxes, Tools and Equipment and Mock-ups for the Mobile Training Laboratories (MTLs).

**TESDA Apayao Provincial Office
Pudtol Luna, Apayao**

| NO. | ITEM | AGENCY SPECS | QTY | UNIT | No. Of Box |
|--|-----------------------|--|-----|---------|------------|
| 66 | HDMI cable | 3 meters, v1.4A HDMI cable for Projector | 1 | pc | 3 |
| 67 | Whiteboard | wooden whiteboard (2' x 3') with frame, 1 meter collapsible high stand | 1 | pc | 3 |
| 68 | PA System | 550W Portable with Trolley, with 2 wireless mics, 220V, RCA port, with warranty | 1 | unit | 3 |
| 69 | Megaphone | with speak and music switch and volume control, 25w | 1 | unit | 3 |
| 70 | First Aid Kit | First Aid Kit with the contents: betadine, alcohol, adhesive strips, band-aid, disposable gloves, hypoallergenic medical tape (1.25 cm x 9.1m), conforming bandage (5cm), triangular bandage (110m x 110cm), wound dressing no. 15, swab antiseptic, tweezers metal 8 cm, scissors disposable, safety pins assorted (12 pcs), hot and cold compress pack, first aid quick reference guide. | 1 | package | 3 |
| Electrical Installation and Maintenance (EiM) NC II Tools and Equipment (for training purposes) | | | | | |
| 1 | Spirit Level | high impact plastic; magnetic; 3 vials; Length:24" | 1 | pc | 2 |
| 2 | Hacksaw | adjustable hacksaw frame with bi-metal hacksaw blade, 24 TPI, aluminum alloy frame and handle | 5 | pc | 2 |
| 3 | Pipe Cutter | max. capacity 1/8-2 " for steel or ductile iron pipes with steel handle | 2 | pc | 2 |
| 4 | Pipe Reamer | 2 " capacity, ratchet type with steel handle, 1/8-2 " capacity, suitable for use with power drives | 2 | pc | 2 |
| 5 | Pipe Threader | drop head with 3 sets of head and dies, sizes (1/2", 3/4", 1") | 2 | unit | 2 |
| 6 | Pipe Bender | manual, 1/2-3/4 inch bending radius, ductile high strength iron | 2 | unit | 2 |
| 7 | Electricians Plier | overall length 6, knife length: 5/8", material: carbon steel handle finished: plastic dipped | 25 | pc | 2 |
| 8 | Long Nose Plier | dyna grip, 152mm/6" inches carbon steel | 25 | pc | 2 |
| 9 | Phillips Screw Driver | 1x75, PH 2 x 100, PH 2x125 plastic and rubberized handle chrome vanadium, shank 4" | 25 | set | 2 |
| 10 | Flat Screw Driver | 3x75, 5x100, 6x125 plastic and rubberized handle chrome vanadium shank 4" | 25 | set | 2 |
| 11 | Wrench, Combination | 6mm,8mm,10mm,11mm,12mm,13mm,14mm,15mm, 16mm,17mm,19mm, 21mm,22mm, 24 mm, chrome vanadium steel | 5 | set | 2 |
| 12 | Wire Stripper | automatic, cap. 1.5mm to 3.5mm | 10 | pc | 2 |
| 13 | Electrician Knife | blade length 3", taper ground cutlery single steel blade, ergonomically designed slip resistant grip | 25 | pc | 2 |
| 14 | Tool Holster | leather, 3 pocket & 4 holes with belt | 25 | pc | 2 |
| 15 | Pull Push Rule | blade length 8 mtrs, blade width 1", high impact ABS case with durable rubber corrosion resistant lru-zero end | 25 | pc | 2 |
| 16 | Claw Hammer | 16 oz., forged steel construction, hardened and tempered steel head, smooth face, wooden handle | 10 | pc | 2 |
| 17 | Heat Gun | 1600 watts, 230v,60 Hz, 12.5 amp. dual temperature, with different nozzle | 2 | unit | 2 |

7 - AN

Procurement of CMU Boxes, Tools and Equipment and Mock-ups for the Mobile Training Laboratories (MTLs).

**TESDA Apayao Provincial Office
Pudtol Luna, Apayao**

| NO. | ITEM | AGENCY SPECS | QTY | UNIT | No. Of Box |
|---|----------------|--|-----|---------|------------|
| 18 | Power Drill | drilling cap.:10mm, cap. wood: 20mm, wattage 350w, no load speed: 0-2500rpm, weight 1.1 kg., Rev - for rotation, 3/8"capacity. 220VAC, 60Hz | 2 | unit | 2 |
| 19 | Multi-Tester | analog, standard-size analog multimeter for measuring voltage, current, and resistance. An auxiliary connector is also provided for checking transistors. Specifications: •DC Voltage Range: 0 to 1000V in seven ranges •AC Voltage Range: 0 to 1000V in five ranges •DC Current Range: 0 to 250mA in four ranges •Resistance Range: x1 to 20KW in four ranges •Transistor hFE Range: -0 to 1000 Leakage Current (ICEO) Range: -0 to 150mAAF Output Range: -10dB to +22dB | 5 | unit | 2 |
| 20 | Clamp Ammeter | digital max. AC voltage measurement 600V, max. AC current measurement 400Aac, max. DC voltage measurement 600Vdc, max. resistance measurement 400ohms, battery type AAA, clamp meter type, continuity current, frequency, resistance, voltage, display type LCD, jaw capacity, bus bars 10x34mm, safety category voltage, 300V, 600V | 2 | unit | 2 |
| 21 | Pipe Vise | capacity 2", material steel, d with swivel base with dual locking nuts, 360 degrees of rotation. | 2 | pc | 2 |
| 22 | Laptop | 15.6", Core i7, 1.40GHz, wide screen, 1TB hard drive, 8GB DDR3 memory, NVIDIA GTX 670MX graphic processor, 3GB video memory, Gigabit 10/100/1000Mbps IEEE802.11b/g/n Wireless LAN, web camera, HDMI, Bluetooth, USB2.0, USB3.0, with Windows 8 OS, up to 6 hours charge-in-use battery, DVDRW super Multi with 1 year warranty | 1 | unit | 2 |
| 23 | MS Office 2013 | Home & Student 1 user | 1 | unit | 2 |
| 24 | Projector | LCD Projector Portable, RGB liquid crystal shutter projection system (3LCD). White Light Output 2,600 lumens, Colour Light Output 2,600 lumens, XGA Resolution, lightweight: less than 2 kgs. | 1 | unit | 2 |
| 25 | HDMI cable | 3 meters, v1.4A HDMI cable for Projector | 1 | pc | 2 |
| 26 | Whiteboard | wooden whiteboard (2' x 3') with frame, 1 meter collapsible high stand | 1 | pc | 2 |
| 27 | PA System | 550W Portable with Trolley, with 2 wireless mics, 220V, RCA port, with warranty | 1 | unit | 2 |
| 28 | Megaphone | with speak and music switch and volume control, 25w | 1 | unit | 2 |
| 29 | First Aid Kit | First Aid Kit with the contents: betadine, alcohol, adhesive strips, band-aid, disposable gloves, hypoallergenic medical tape (1.25 cm x 9.1m), conforming bandage (5cm), triangular bandage (110m x 110cm), wound dressing no. 15, swab antiseptic, tweezers metal 8 cm, scissors disposable, safety pins assorted (12 pcs), hot and cold compress pack, first aid quick reference guide. | 1 | package | 2 |
| Plumbing NC II Tools and Equipment (for training purposes) | | | | | |

T W
dy

Procurement of CMU Boxes, Tools and Equipment and Mock-ups for the Mobile Training Laboratories (MTLs).

**TESDA Apayao Provincial Office
Puttol Luna, Apayao**

| NO. | ITEM | AGENCY SPECS | QTY | UNIT | No. Of Box |
|-----|-------------------------------|--|-----|------|------------|
| 1 | Pipe Wrench | 12" straight, heavy duty, forged alloy steel 12", pipe capacity 2" or 50mm, weight 1.2 kg. cast-iron housing and I-beam handle with full floating forged hook jaw, featuring self cleaning threads with replaceable hook and heel jaws | 5 | pc | 3 |
| 2 | Pipe Wrench | 14" straight, heavy duty, forged alloy steel 12", pipe capacity 2" or 50mm, weight 1.6 kg. cast-iron housing and I-beam handle with full floating forged hook jaw, featuring self cleaning threads with replaceable hook and heel jaws | 5 | pc | 3 |
| 3 | Pull Push Rule | blade length 8 mtrs, blade width 1", high impact ABS case with durable rubber corrosion resistant Iru-zero end | 10 | pc | 3 |
| 4 | Hacksaw | adjustable hacksaw frame with bi-metal hacksaw blade, 24 TPI, aluminum alloy frame and handle | 5 | pc | 3 |
| 5 | Spirit Level | high impact plastic, magnetic, 3 vials; Length:24" | 5 | pc | 3 |
| 6 | Pipe Reamer | 2 " capacity, ratchet type with steel handle, 1/8-2 " capacity, suitable for use with power drives | 5 | pc | 3 |
| 7 | Pipe Cutter | max. capacity 1/8-2 " for steel or ductile iron pipes with steel handle | 5 | pc | 3 |
| 8 | Adjustable Wrench | alloy steel, 0 - 2 " jaw opening, 10" length | 5 | pc | 3 |
| 9 | Mechanical Plier | mechanical, plastic dipped insulated handle, 6 " length, rust-resistant chrome finish, two position adjustable joint pliers | 5 | pc | 3 |
| 10 | Pipe Vise | capacity 2", material steel, d with swivel base with dual locking nuts, 360 degrees of rotation. | 2 | pc | 3 |
| 11 | Pipe Threader | drop head with 3 sets of head and dies, sizes (1/2", 3/4", 1") | 2 | pc | 3 |
| 12 | Portable Tri-stand Chain Vise | 1/8 to 6 in., rear pipe support, rugged tool tray capacity: 1/8" - 6", leg locking: over center tool tray | 3 | pc | 3 |
| 13 | Manual Pressure Test Pump | 6 mpa, 860 psi max. pressure, 12 L. capacity, with brass pump valve | 1 | pc | 3 |
| 14 | Socket Fusion Machine | 20 mm - 32 mm cap, 3/4", 1", 1-1/4" and 1-1/2", 220V, 1600w | 2 | pc | 3 |
| 15 | Ballpeen hammer | 12 oz., 11 1/2" overall length forged steel construction, hardened and tempered, wooden handle | 5 | pc | 3 |
| 16 | Angle Grinder | 4 "diameter, wheel cap, 220V, 60 Hz, single phase, 11,000 rpm, all-ball bearing design and metal gear | 2 | pc | 3 |
| 17 | Electric Portable Drill | 1/2 " bit jaw capacity, 220V, single phase, variable speed (0-550 rpm), heavy duty, 1/2" drill chuck | 1 | pc | 3 |
| 18 | Carpenter Steel Square | high tempered aluminum steel, 2" x 16" x 24", 5-60 and 30-degree angle markings, high tempered aluminum for maximum durability, 1/8-inch graduations for long-term visibility, body: 24 by 2-inches, tongue: 16 by 1-1/2" | 4 | pc | 3 |
| 19 | Claw Hammer | 16 oz., forged steel construction, hardened and tempered steel head, smooth face, wooden handle | 5 | pc | 3 |
| 20 | Paint Brush | 1/2" round trim brush soft bristle, tin-plated ferrules | 10 | pc | 3 |
| 21 | Hand Gloves | 5 finger, poly/cotton blend with a latex coated palm | 25 | pc | 3 |

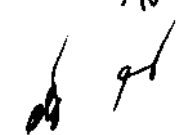
1

Procurement of CMU Boxes, Tools and Equipment and Mock-ups for the Mobile Training Laboratories (MTLs).

**TESDA Apayao Provincial Office
Pudtol Luna, Apayao**

| NO. | ITEM | AGENCY SPECS | QTY | UNIT | No. Of Box |
|--|---------------------------|--|-----|---------|------------|
| 22 | Safety Hard Hat | V-rib, yellow ball-cap style hard hat with 6 point ratchet-type headgear, 2 point chin strap and V rib on top, polyethylene material | 25 | pc | 3 |
| 23 | Safety Shoes | heavy duty steel toe cap, waterproof, anti static (sizes 40-42) Its anti-static and heat resistant (up to 300 degree C/572 degree F) with TPU SAFETY cell construction steel toe cap | 25 | pc | 3 |
| 24 | Safety Goggles | clear polycarbonate, woven elastic strap (adjustable) | 25 | pc | 3 |
| 25 | Water Meter | multi jet plastic meter, 1/2" NPT, 20 gpm, brass body | 1 | pc | 3 |
| 26 | Water Closet | flush type, ceramic, dimension (LxVxH): 684x430x787 mm, flushing action: siphonic, single/dual flush: single flush, flush Volume: 6L, flushing activation: front lever, rough-in: 305mm, discharge: floor cover | 1 | pc | 3 |
| 27 | Lavatory with Faucet | center hole, with mixing hot and cold faucet, ceramic, wall hung type, wall hung sink, 4-inch center faucet holes, front overflow, self-draining deck area with contoured back and side splash shields | 2 | pc | 3 |
| 28 | Kitchen Sink with Faucet | stainless steel, rust and heat resistant, grade 304, 74 cm x 51.5 cm, 16.2 mm outlet hole | 1 | pc | 3 |
| 29 | Single Point Water Heater | 4.5kw, 220V, 60 Hz, 2 psi min water pressure, 55 psi, 2 L/min minimum water flow, 1/2" BSP | 2 | pc | 3 |
| 30 | Laptop | 15.6", Core i7, 1.40GHz, wide screen, 1TB hard drive, 8GB DDR3 memory, NVIDIA GTX 670MX graphic processor, 3GB video memory, Gigabit 10/100/1000Mbps IEEE802.11b/g/n Wireless LAN, web camera, HDMI, Bluetooth, USB2.0, USB3.0, with Windows 8 OS, up to 6 hours charge-in-use battery, DVDRW super Multi with 1 year warranty | 1 | unit | 3 |
| 31 | MS Office 2013 | Home & Student 1 user | 1 | unit | 3 |
| 32 | Projector | LCD Projector Portable, RGB liquid crystal shutter projection system (3LCD), White Light Output 2,600 lumens, Colour Light Output 2,600 lumens, XGA Resolution, lightweight: less than 2 kgs. | 1 | unit | 3 |
| 33 | HDMI cable | 3 meters, v1.4A HDMI cable for Projector | 1 | pc | 3 |
| 34 | Whiteboard | wooden whiteboard (2' x 3') with frame, 1 meter collapsible high stand | 1 | pc | 3 |
| 35 | PA System | 550W Portable with Trolley, with 2 wireless mics, 220V, RCA port, with warranty | 1 | unit | 3 |
| 36 | Megaphone | with speak and music switch and volume control, 25w | 1 | unit | 3 |
| 37 | First Aid Kit | First Aid Kit with the contents: betadine, alcohol, adhesive strips, band-aid, disposable gloves, hypoallergenic medical tape (1.25 cm x 9.1m), conforming bandage (5cm), triangular bandage (110m x 110cm), wound dressing no. 15, swab antiseptic, tweezers metal 8 cm, scissors disposable, safety pins assorted (12 pcs), hot and cold compress pack, first aid quick reference guide. | 1 | package | 3 |
| Small Engine Repair (Motorcycle/Small Engine Servicing NC II) Tools and Equipment (for training purposes) | | | | | |
| 1 | Impact Drive Tool | 4pcs, 1/2" Impact Driver Set, heavy duty. | 10 | set | 4 |

1
Handwritten initials and signature

Procurement of CMU Boxes, Tools and Equipment and Mock-ups for the Mobile Training Laboratories (MTLs).

**TESDA Apayao Provincial Office
Puttol Luna, Apayao**

| NO. | ITEM | AGENCY SPECS | QTY | UNIT | No. Of Box |
|-----|----------------------------|---|-----|------|------------|
| 2 | Multi-Tester | analog, standard-size analog multimeter for measuring voltage, current, and resistance. An auxiliary connector is also provided for checking transistors. Specifications: •DC Voltage Range: 0 to 1000V in seven ranges •AC Voltage Range: 0 to 1000V in five ranges •DC Current Range: 0 to 250mA in four ranges •Resistance Range: x1 to 20KW in four ranges •Transistor hFE Range: -0 to 1000 •Transistors Leakage Current (ICEO) Range: -0 to 150mAAF Output Range: -10dB to +22dB | 10 | pc | 4 |
| 3 | Oiler | metal case, 1/2 liter cap | 10 | pc | 4 |
| 4 | Steel Brush | wooden handle | 10 | pc | 4 |
| 5 | Hacksaw | adjustable hacksaw frame with bi-metal hacksaw blade, 24 TPI, aluminum alloy frame and handle | 10 | pc | 4 |
| 6 | Center Punch | high speed steel, 5x125 mm | 10 | pc | 4 |
| 7 | Cold Chisel | flat blade, 1" (W), 6" (L), hardened steel | 10 | pc | 4 |
| 8 | Fly Wheel/Magneto Puller | universal type, six in one fly wheel/ magneto puller | 10 | pc | 4 |
| 9 | Oil Seal Remover/Installer | pointed tip, hardened steel w/ straight handle, 3 pcs per set | 10 | set | 4 |
| 10 | Piston Ring Compressor | self locking w/ L wrench steel, range 2 1/8" to 5 inch diameter | 10 | pc | 4 |
| 11 | Valve Spring Compressor | spring loaded offset jaw overhead valve spring compressor, steel | 10 | pc | 4 |
| 12 | Clutch Assembly Remover | universal compressor clutch hub for removal and installation | 10 | pc | 4 |
| 13 | Electricians Plier | overall length 6, knife length: 5/8", material: carbon steel handle finished: plastic dipped | 10 | pc | 4 |
| 14 | Diagonal Cutting Plier | dyna grip, 152mm/6" inches carbon steel | 10 | pc | 4 |
| 15 | Mechanical Plier | 8", insulated handle | 10 | pc | 4 |
| 16 | Vise Grippd Plier | 10R straight jaw | 10 | pc | 4 |
| 17 | Feeler Gauge | 26 blade feeler gauge set, metric & English marked gauge | 10 | pc | 4 |
| 18 | Screwdriver, Flat | 8", magnetic tip, chrome vanadium, plastic handle | 10 | pc | 4 |
| 19 | Screwdriver, Philips | 8", magnetic tip, chrome vanadium, plastic handle | 10 | pc | 4 |
| 20 | Ballpeen hammer | 12 oz., 11 1/2" overall length forged steel construction, hardened and tempered, wooden handle | 10 | pc | 4 |
| 21 | Hammer, Brass/copper | 1 lb., wooden handle | 10 | pc | 4 |
| 22 | Hammer, Plastic | 1 lb, wooden handle, plastic tip hammer | 10 | pc | 4 |
| 23 | Wrench, Sparkplug | 19x16 mm, hexagonal w/ handle | 10 | pc | 4 |
| 24 | Wrench, Combination | 6mm,8mm,10mm,11mm,12mm,13mm,14mm,15mm, 16mm,17mm,19mm, 21mm,22mm, 24 mm, chrome vanadium steel | 10 | set | 4 |
| 25 | Wrench, Socket | 8 - 32 mm., black, 1/2" drive | 10 | set | 4 |
| 26 | Wrench, T-type | 8, 10, 12, 14 mm | 10 | set | 4 |
| 27 | Hand Tractor Engine | diesel engine, single piston, 4 stroke direct injection, 10-12 hp | 2 | unit | 4 |

9
get ✓
alf

Procurement of CMU Boxes, Tools and Equipment and Mock-ups for the Mobile Training Laboratories (MTLs).

**TESDA Apayao Provincial Office
Puttol Luna, Apayao**

| NO. | ITEM | AGENCY SPECS | QTY | UNIT | No. Of Box |
|-----|----------------|--|-----|---------|------------|
| 28 | Laptop | 15.6", Core i7, 1.40GHz, wide screen, 1TB hard drive, 8GB DDR3 memory, NVIDIA GTX 670MX graphic processor, 3GB video memory, Gigabit 10/100/1000Mbps IEEE802.11b/g/n Wireless LAN, web camera, HDMI, Bluetooth, USB2.0, USB3.0, with Windows 8 OS, up to 6 hours charge-in-use battery, DVDRW super Multi with 1 year warranty | 1 | unit | 4 |
| 29 | MS Office 2013 | Home & Student 1 user | 1 | unit | 4 |
| 30 | Projector | LCD Projector Portable, RGB liquid crystal shutter projection system (3LCD), White Light Output 2,600 lumens, Colour Light Output 2,600 lumens, XGA Resolution, lightweight: less than 2 kgs. | 1 | unit | 4 |
| 31 | HDMI cable | 3 meters, v1.4A HDMI cable for Projector | 1 | pc | 4 |
| 32 | Whiteboard | wooden whiteboard (2' x 3') with frame, 1 meter collapsible high stand | 1 | pc | 4 |
| 33 | PA System | 550W Portable with Trolley, with 2 wireless mics, 220V, RCA port, with warranty | 1 | unit | 4 |
| 34 | Megaphone | with speak and music switch and volume control, 25w | 1 | unit | 4 |
| 35 | First Aid Kit | First Aid Kit with the contents: betadine, alcohol, adhesive strips, band-aid, disposable gloves, hypoallergenic medical tape (1.25 cm x 9.1m), conforming bandage (5cm), triangular bandage (110m x 110cm), wound dressing no. 15, swab antiseptic, tweezers metal 8 cm, scissors disposable, safety pins assorted (12 pcs), hot and cold compress pack, first aid quick reference guide. | 1 | package | 4 |

7

**Procurement of CMU Boxes, Tools and Equipment and Mock-ups for
the Mobile Training Laboratories (MTLs).**

**TESDA Apayao Provincial Office
Pudtol Luna, Apayao**

| No. | Item / Description | Qty. | Unit | No. of Mock-up |
|--|---|------|-------|----------------|
| Electrical Installation and Maintenance (EIM) NC II Mock-up | | | | |
| 1 | Electrical Installation Maintenance (EIM) Mock-Up | 1 | lot | 1 |
| SUPPLIES AND MATERIALS | | | | |
| 2 | Heat gun, 1200 watts | 1 | pc | 1 |
| 3 | PVC adapter with lock nuts | 20 | pc | 1 |
| 4 | Circuit breaker, 30A | 2 | pc | 1 |
| 5 | 1/2" diameter PVC pipe | 2 | meter | 1 |
| 6 | Cable ties, 100 pcs./pack | 1 | pack | 1 |
| 7 | Incandescent bulb, 220V, 25W | 5 | pc | 1 |
| 8 | One pole switch with plate, flush type | 5 | pc | 1 |
| 9 | Three way switch with plate, flush type | 5 | pc | 1 |
| 10 | Four way switch with plate, flush type | 5 | pc | 1 |
| 11 | Lamp receptacle 4" X 4" surface type | 5 | pc | 1 |
| 12 | Photo electrical (photocell) | 1 | pc | 1 |
| 13 | Convenience outlet, universal type | 5 | pc | 1 |
| 14 | Floor outlet, round type | 1 | pc | 1 |
| 15 | Ground fault current interrupter | 1 | pc | 1 |
| 16 | Circuit breaker 60A with built in housing | 1 | pc | 1 |
| 17 | Terminal block 15A 12 slots | 40 | pc | 1 |
| 18 | Automotive Wire #14 AWG (1 solid and 1 stranded) | 2 | roll | 1 |
| 19 | Terminal lug, Y type | 150 | pc | 1 |
| This include supplies and materials required in the fabrication of mock-up | | | | |
| Plumbing NC II Mock-up | | | | |
| 1 | Plumbing Mock-up (Labor Cost) | 1 | lot | 1 |
| SUPPLIES AND MATERIALS | | | | |
| 2 | 4" dia PVC Pipe (Orange) | 1 | pc | 1 |
| 3 | 4" dia. PVC Elbow 90 deg. | 1 | pc | 1 |
| 4 | 4" dia. PVC Elbow 45 deg. | 1 | pc | 1 |
| 5 | 4" dia. PVC Clean Out | 1 | pc | 1 |
| 6 | 4" x 3" PVC Wye | 1 | pc | 1 |
| 7 | 4" x 2" PVC Wye | 3 | pc | 1 |
| 8 | 3" dia. PVC pipe | 1 | pc | 1 |
| 9 | 3" PVC Elbow | 1 | pc | 1 |
| 10 | 3" PVC Elbow 45 deg. | 1 | pc | 1 |
| 11 | 3" x 2" PVC Tee | 1 | pc | 1 |
| 12 | 3" x 3" PVC Tee | 1 | pc | 1 |
| 13 | 2" dia PVC Pipe | 2 | pc | 1 |
| 14 | 2" dia. PVC Elbow 45 deg. | 3 | pc | 1 |

7
N
af

**Procurement of CMU Boxes, Tools and Equipment and Mock-ups for
the Mobile Training Laboratories (MTLs).**

**TESDA Apayao Provincial Office
Pudtol Luna, Apayao**

| No. | Item / Description | Qty. | Unit | No. of Mock-up |
|--|--|------|-------|----------------|
| 15 | 2" dia. PVC Elbow 90 deg. | 3 | pc | 1 |
| 16 | 2" PVC Tee | 4 | pc | 1 |
| 17 | 2" PVC P-trap | 2 | pc | 1 |
| 18 | 1/2" dia. PPr pipe | 2 | pc | 1 |
| 19 | 1/2" dia. PPr elbow | 7 | pc | 1 |
| 20 | 1/2" dia. PPr tee | 4 | pc | 1 |
| 21 | 1/2" dia. PPr elbow connector | 6 | pc | 1 |
| 22 | 1/2" dia. PPr male connector | 2 | pc | 1 |
| 23 | 1/2" dia. PPr union | 3 | pc | 1 |
| 24 | 1/2" dia. PPr coupling | 4 | pc | 1 |
| 25 | Urinal 480mm X 730mm X 730mm with complete accessories | 1 | unit | 1 |
| 26 | Shower head with complete accessories | 1 | unit | 1 |
| 27 | 1/2 x 7/8 flexible hose | 1 | pc | 1 |
| 28 | 1/2 x 1/2" angle valve | 3 | pc | 1 |
| 29 | 3/4" x 4' x 8' Marine Plywood | 1 | pc | 1 |
| 30 | 2" x 2" x 12' Lumber | 4 | pc | 1 |
| 31 | Teflon Tape | 10 | pc | 1 |
| 32 | Metal hinges 2" X 4", heavy duty | 3 | pc | 1 |
| This include supplies and materials required in the fabrication of mock-up | | | | |
| Small Engine Repair (Motorcycle/Small Engine Servicing NC II) Tools and Equipment Mock-up | | | | |
| 1 | Motorcycle/Small Engine Collapsible Mock-Up | 1 | lot | 1 |
| SUPPLIES AND MATERIALS: | | | | |
| 2 | Auto wire, stranded # 16 | 1 | roll | 1 |
| 3 | Electrical tape, large black | 2 | pc | 1 |
| 4 | Head light assembly, 12 volts rectangular | 1 | pc | 1 |
| 5 | signal light assembly, 12 volts | 2 | pair | 1 |
| 6 | Horn, 12 volts | 1 | pc | 1 |
| 7 | Stop light switch, push button | 1 | pc | 1 |
| 8 | Signal light switch, double throw, toggle switch | 1 | pc | 1 |
| 9 | Ignition switch, gas engine type | 1 | pc | 1 |
| 10 | Signal light relay, 12 volts | 1 | pc | 1 |
| 11 | Push button switch for horn | 1 | pc | 1 |
| 12 | Motorcycle storage battery, 12 volts maintenance free | 1 | pc | 1 |
| 13 | Harness cover, 3/8" diameter (140/4) | 4 | meter | 1 |
| 14 | Harness connector, 6 terminals | 4 | pc | 1 |
| 15 | Male terminal, flat | 30 | pc | 1 |
| 16 | Female terminal, flat | 30 | pc | 1 |
| 17 | Headlight switch or toggle switch, single throw | 1 | pc | 1 |
| 18 | Crocodile clip, medium, red and black | 1 | pair | 1 |
| 19 | 3/16" diameter X 3/4" stove bolt, stainless | 20 | pc | 1 |
| 20 | 3/16" diameter hole, eye terminal | 10 | pc | 1 |
| 21 | Four stroke motorcycle engine, 125 or 155cc, surplus | 1 | unit | 1 |
| This include supplies and materials required in the fabrication of mock-up | | | | |

7
9/27
af

Procurement of CMU Boxes, Tools and Equipment and Mock-ups for the Mobile Training Laboratories (MTLs).

**TESDA Masbate Provincial Office
Capitol Road, Masbate City**

| NO. | ITEM | AGENCY SPECS | QTY | UNIT | No. Of Box |
|---|--|---|-----|------|------------|
| Appliance Repair NC II Tools and Equipment (for training purposes) | | | | | |
| 1 | Soldering Iron | dual wattage, 25 watts/ 120watts, 220 volt 60 Hz, with long life tip, "gun type" | 25 | unit | 3 |
| 2 | Desoldering Tools | desoldering pump with precision regulated return, replacement tip compact, metal housing | 25 | unit | 3 |
| 3 | Screw driver assorted (Phillips and slotted) | 12x7x1 inches, 6 pieces per set, plastic handle | 5 | set | 3 |
| 4 | Long Nose Plier | dyna grip, 152mm/6" inches carbon steel | 5 | pc | 3 |
| 5 | Diagonal Cutting Plier | dyna grip, 152mm/6" inches carbon steel | 5 | pc | 3 |
| 6 | Nut Drivers | rust-resistant, nickel-plated bar, hexagonal shank, includes: 5mm, 6mm, 7mm, 8mm, 9mm, 10mm, 11mm | 5 | set | 3 |
| 7 | Wrench, Combination | 6mm, 8mm, 10mm, 11mm, 12mm, 13mm, 14mm, 15mm, 16mm, 17mm, 19mm, 21mm, 22mm, 24 mm, chrome vanadium steel | 5 | set | 3 |
| 8 | Wire Stripper | automatic, cap. 1.5mm to 3.5mm | 10 | pc | 3 |
| 9 | Ballpeen hammer | 12 oz., 11 1/2" overall length forged steel construction, hardened and tempered, wooden handle | 5 | pc | 3 |
| 10 | Flashlight | LED, 3 volts/6 volts, rechargeable | 5 | pc | 3 |
| 11 | Detector Light | test light, 220 volts | 5 | pc | 3 |
| 12 | Paint Brush | 4 inches width, wooden handle | 25 | pc | 3 |
| 13 | Microwave Oven | power capacity: 220V 1300 watts, interior capacity 20 liters, 8 programmes, defrost option, 26cm diameter rotating turntable, digital | 1 | unit | 3 |
| 14 | Washing Machine with dryer | power capacity: 500w, 220V, rust proof body, gear drive system, dolphin drive pulsator, washing capacity (dry weight) 7.5kg, spinning capacity (dry weight) 5.5kg, width should be more than 50 cm and length of not more than 100 cm | 1 | unit | 3 |
| 15 | Electric Fan | power capacity: 220V, 100w, 60Hz, 3 speed rotary switch, 18 inch metal blade, round/stable plastic base, thermal fuse protection, adjustable height stand fan | 1 | unit | 3 |
| 16 | Electric Rice Cooker | power capacity: 700w, 220V, 60Hz, automatic cooking feature, auto shutoff, glass lid, non-stick coated aluminum pan, includes measuring cup and rice scoop | 1 | unit | 3 |

Handwritten marks:
 7 9
 25 2

Procurement of CMU Boxes, Tools and Equipment and Mock-ups for the Mobile Training Laboratories (MTLs).

**TESDA Masbate Provincial Office
Capitol Road, Masbate City**

| NO. | ITEM | AGENCY SPECS | QTY | UNIT | No. Of Box |
|-----|--------------------|---|-----|------|------------|
| 17 | Electric Flat Iron | power capacity: 1000w, 220V, 60 Hz, non-stick Teflon soleplate, thermal fuse protected, variable temperature control, automatic thermostat Control, pilot lamp indicator | 1 | unit | 3 |
| 18 | Coffee Maker | power capacity: 550w, 220V, 60Hz, glass pitcher, anti-drip feature, 6 cup water capacity, water level indicator, swing-out filter basket | 1 | unit | 3 |
| 19 | Oven Toaster | power capacity: 1000w, 220V, 60Hz, stainless steel, 8 liter capacity, 15 minute timer, slide out chrome crumb rack, includes baking tray | 1 | unit | 3 |
| 20 | Blender | 1.5 liter capacity, rated voltage, 230V, 60Hz, power consumption: 300 watts, sharp stainless steel blade, safety lock switch, with plastic stirrer for easy mixing | 1 | unit | 3 |
| 21 | Multi Tester | analog, standard size analog multimeter for measuring voltage, current and resistance. An auxiliary connector is also provided for checking transistors. SPECIFICATION: <ul style="list-style-type: none"> •DC Voltage Range: 0 to 1000V in seven ranges •AC Voltage Range: 0 to 1000V in five ranges •DC Current Range: 0 to 250mA in four ranges •Resistance Range: x1 to 200MEG in four ranges •Transistor hFE Range: -0 to 1000 •Transistors Leakage Current (ICEO) Range: -0 to 150mAAF Output Range: -10dB to +22dB | 25 | unit | 3 |
| 22 | Multi Tester | Digital Multi meters are standard digital multimeter for measuring voltage, current, and resistance with 3-1/2 digit LCD display. This meter measures only 138mm x 70mm x 32mm and weighs approximately 140 grams, including battery. SPECIFICATION: <ul style="list-style-type: none"> •DC Voltage Range: 200mV to 600V in five ranges (auto ranging) •AC Voltage Range: 2V to 600V in four ranges (auto ranging) •DC Current Range: 200mA to 10A in six ranges •Resistance Range: 200 Ohms to 20M in six ranges Transistor hFE Test Range: 0 to 2000 | 25 | unit | 3 |
| 23 | Laptop | 15.6", Core i7, 1.40GHz, wide screen, 1TB hard drive, 8GB DDR3 memory, NVIDIA GTX 670MX graphic processor, 3GB video memory, Gigabit 10/100/1000Mbps IEEE802.11b/g/n Wireless LAN, web camera, HDMI, Bluetooth, USB2.0, USB3.0, with Windows 8 OS, up to 6 hours charge-in-use battery, DVDRW super Multi with 1 year warranty | 1 | unit | 3 |

Handwritten signature and initials

Procurement of CMU Boxes, Tools and Equipment and Mock-ups for the Mobile Training Laboratories (MTLs).

**TESDA Masbate Provincial Office
Capitol Road, Masbate City**

| NO. | ITEM | AGENCY SPECS | QTY | UNIT | No. Of Box |
|---|-----------------------|--|-----|---------|------------|
| 24 | MS Office 2013 | Home & Student 1 user | 1 | unit | 3 |
| 25 | Projector | LCD Projector Portable, RGB liquid crystal shutter projection system (3LCD), White Light Output 2,600 lumens, Colour Light Output 2,600 lumens, XGA Resolution, lightweight: less than 2 kgs. | 1 | unit | 3 |
| 26 | HDMI cable | 3 meters, v1.4A HDMI cable for Projector | 1 | pc | 3 |
| 27 | Whiteboard | wooden whiteboard (2' x 3') with frame, 1 meter collapsible high stand | 1 | pc | 3 |
| 28 | PA System | 550W Portable with Trolley, with 2 wireless mics, 220V, RCA port, with warranty | 1 | unit | 3 |
| 29 | Megaphone | with speak and music switch and volume control, 25w | 1 | unit | 3 |
| 30 | First Aid Kit | First Aid Kit with the contents: betadine, alcohol, adhesive strips, band-aid, disposable gloves, hypoallergenic medical tape (1.25 cm x 9.1m), conforming bandage (5cm), triangular bandage (110m x 110cm), wound dressing no. 15, swab antiseptic, tweezers metal 8 cm, scissors disposable, safety pins assorted (12 pcs), hot and cold compress pack, first aid quick reference guide. | 1 | package | 3 |
| Bread and Pastry NC II Tools and Equipment (for training purposes) | | | | | |
| 1 | Measuring Cup, dry | stainless steel, 4 pcs/set (1c, 1/2c, 1/3c & 1/4c) | 12 | pc | 3 |
| 2 | Measuring Cup, liquid | glass graduated, 250 ml capacity | 12 | pc | 3 |
| 3 | Measuring Spoon | Stainless steel 6 pcs/set(1/8 tsp,1/4 tsp,1/2tsp,1 tsp 1/2 tbsp,1 tbsp) | 12 | set | 3 |
| 4 | Cake Turn Table | plastic cake turntable with locking switch, rubberized feet, white, 12.6x12.6x3.54 inches (LxWxH) | 10 | pc | 3 |
| 5 | Decorating Tips | stainless steel, 24-piece cake decorating tip set, package size: 17cm x 12cm x 5cm (6.69 x 4.72 x 1.97inches) | 25 | set | 3 |
| 6 | Rolling Pin | wooden, size 33.5 x 5cm, light weight comfortable grip | 25 | pc | 3 |
| 7 | Pie Plate, size 6" | aluminum pie pan, 6" diameter x 5/8 in deep, heavy weight round pan | 10 | pc | 3 |
| 8 | Pie Plate, size 8" | pie pan, 8" aluminum deep dish pie pan, standard weight aluminum, 8" top outside diameter | 10 | pc | 3 |
| 9 | Pie Plate, size 10" | deep aluminum pie pan, 10" diameter, depth 1-1/4", made of 0.7mm thick satin finished aluminum | 10 | pc | 3 |
| 10 | Jelly Roll Pan | aluminum, dimension: 2" x 13 x 8' (HxWxD) | 10 | pc | 3 |

T W gu
afg

Procurement of CMU Boxes, Tools and Equipment and Mock-ups for the Mobile Training Laboratories (MTLs).

**TESDA Masbate Provincial Office
Capitol Road, Masbate City**

| NO. | ITEM | AGENCY SPECS | QTY | UNIT | No. Of Box |
|-----|----------------------|--|-----|------|------------|
| 11 | Cake Spring Form Pan | heavy aluminum spring form pan, heavy duty frame, spring form sides for easy removal, size 9 x 3" | 10 | pc | 3 |
| 12 | Pie Cutter | triple riveted pizza cutter, made of stainless steel, rolling wheel slicer, 6" | 10 | pc | 3 |
| 13 | Rubber Scraper | rubber head, high heat resistant, flexible, 12", color white | 25 | pc | 3 |
| 14 | Spatula | Stainless steel straight blade, 14 inches long with wood handle | 25 | pc | 3 |
| 15 | Cake Stand with tier | 3 tier cake round acrylic cake stand, 3 plates clear, size: 15cm, 20cm, 25cm, 10 inches gap between each tier | 6 | set | 3 |
| 16 | Saucepan | Stainless steel with cover and handle 26cm | 15 | pc | 3 |
| 17 | Ladle | stainless steel, 12 inches, comes with brush finished handle, hole in the handle for easy hanging | 10 | pc | 3 |
| 18 | Chef Knife | 8 inch, stainless steel full tang blade with plastic handle | 12 | pc | 3 |
| 19 | Chopping Board | 12 x 17 inches, polyethylene, easy grip handle, white color | 10 | pc | 3 |
| 20 | Weighing Scale | manual, maximum weight capacity 2kg, graduated by grams, removable and washable tray | 6 | pc | 3 |
| 21 | Grater | made of nonreactive stainless steel easy grip handle | 10 | pc | 3 |
| 22 | Wooden Spoon | wooden turner, size 12 inches | 25 | pc | 3 |
| 23 | Piping Bag | 12 inches, light weight, reusable, flexible polyester, coated can be boiled, dishwasher safe | 25 | pc | 3 |
| 24 | Mixing Bowl | 12 inches diameter, 8-9 quarts capacity, stainless | 15 | pc | 3 |
| 25 | Wire Whisk | 8"/20cm, aluminum, balloon style | 25 | pc | 3 |
| 26 | Electric Mixer | 4 qt. stainless steel bowl, 5 speeds & quick burst button, bowl rest TM mixer stabilizer, doubles as a hand mixer, 220V, 290-watts peak power, versatile attachment set includes traditional beaters, whisk and dough hooks, brushed stainless steel | 5 | unit | 3 |
| 27 | Dough Cutter | dough scraper 6" wide x 4", high polished stainless steel blade | 10 | pc | 3 |
| 28 | Oven (gas) | stainless door, 2 trays oven with tempered glass window, 22-25" collapsible stand | 1 | unit | 3 |
| 29 | Pastry Brush | pastry/basting brush, natural wood handle brushes, 1.5" size | 10 | pc | 3 |
| 30 | Bread Knife | 8", serrated edge stain free high-carbon steel blade texture red polypropylene handle | 10 | pc | 3 |

Procurement of CMU Boxes, Tools and Equipment and Mock-ups for the Mobile Training Laboratories (MTLs).

**TESDA Masbate Provincial Office
Capitol Road, Masbate City**

| NO. | ITEM | AGENCY SPECS | QTY | UNIT | No. Of Box |
|--|---------------------|--|-----|---------|------------|
| 31 | Flour Sifter | stainless steel mesh flour sifter strainer, 12" | 10 | pc | 3 |
| 32 | Baking Sheet | aluminum , 13" x 18" | 15 | pc | 3 |
| 33 | Muffin Pans | 12 holes, 3 oz. capacity per holes, aluminum | 25 | pc | 3 |
| 34 | Working Table | high quality stainless steel foldable tables dimension: 3ft x 3ft | 4 | pc | 3 |
| 35 | Gas Stove with tank | 2 burner, made from stainless top body, automatic ignition, with complete accessories | 2 | pc | 3 |
| 36 | Kitchen Sink | Kitchen sink, portable single bowl sink stainless steel, with steel collapsible frame legs, with drain hose, Dimension 50cmx50cmx30cm | 1 | pc | 3 |
| 37 | Weighing Scale | digital, 1000g, maximum weight capacity, battery operated (AAA battery) 0.1 g to 1000g , LCD display battery included. | 5 | pc | 3 |
| 38 | Laptop | 15.6", Core i7, 1.40GHz, wide screen, 1TB hard drive, 8GB DDR3 memory, NVIDIA GTX 670MX graphic processor, 3GB video memory, Gigabit 10/100/1000Mbps IEEE802.11b/g/n Wireless LAN, web camera, HDMI, Bluetooth, USB2.0, USB3.0, with Windows 8 OS, up to 6 hours charge-in-use battery, DVDRW super Multi with 1 year warranty | 1 | unit | 3 |
| 39 | MS Office 2013 | Home & Student 1 user | 1 | unit | 3 |
| 40 | Projector | LCD Projector Portable, RGB liquid crystal shutter projection system (3LCD), White Light Output 2,600 lumens, Colour Light Output 2,600 lumens, XGA Resolution, lightweight: less than 2 kgs. | 1 | unit | 3 |
| 41 | HDMI cable | 3 meters, v1.4A HDMI cable for Projector | 1 | pc | 3 |
| 42 | Whiteboard | wooden whiteboard (2' x 3') with frame, 1 meter collapsible high stand | 1 | pc | 3 |
| 43 | PA System | 550W Portable with Trolley, with 2 wireless mics, 220V, RCA port, with warranty | 1 | unit | 3 |
| 44 | Megaphone | with speak and music switch and volume control, 25w | 1 | unit | 3 |
| 45 | First Aid Kit | First Aid Kit with the contents: betadine, alcohol, adhesive strips, band-aid, disposable gloves, hypoallergenic medical tape (1.25 cm x 9.1m), conforming bandage (5cm), triangular bandage (110m x 110cm), wound dressing no. 15, swab antiseptic, tweezers metal 8 cm, scissors disposable, safety pins assorted (12 pcs), hot and cold compress pack, first aid quick reference guide. | 1 | package | 3 |
| Cookery NC II Tools and Equipment (for training purposes) | | | | | |
| 1 | Chef Knife | 8 inch, stainless steel full tang blade with plastic handle | 10 | pc | 3 |

Procurement of CMU Boxes, Tools and Equipment and Mock-ups for the Mobile Training Laboratories (MTLs).

**TESDA Masbate Provincial Office
Capitol Road, Masbate City**

| NO. | ITEM | AGENCY SPECS | QTY | UNIT | No. Of Box |
|-----|--------------------------|--|-----|------|------------|
| 2 | Boning Knife | 6 inches, stainless steel with sharp cutting edge with plastic handle | 8 | pc | 3 |
| 3 | Oyster Knife | 7 inches length (3 inches blade and 4 inches handle), stainless steel blade, with comfortable plastic handle | 4 | pc | 3 |
| 4 | Cleaver Knife | 7 inches, stain resistant carbon steel blade | 2 | pc | 3 |
| 5 | Tenderizer | with flat and textured side, non slip, 10 inches 25.5 cm, solid aluminum construction | 8 | pc | 3 |
| 6 | Skimmer | fine, extra fine mesh, 6 inches diameter, with stainless handle | 8 | pc | 3 |
| 7 | Wire Skimmer | small, nickel plated wire oil skimmer, 16 inches long overall, 5 inches diameter bowl | 8 | pc | 3 |
| 8 | Skimmer | spider, 5 inches diameter, natural bamboo handle, constructed of durable stainless steel with versatile woven design | 8 | pc | 3 |
| 9 | Strainer, small | fine, 6" diameter, with stainless handle | 8 | pc | 3 |
| 10 | Siever | small 12" diameter, stainless | 8 | pc | 3 |
| 11 | Strainer, medium | medium, fine stainless steel mesh, 9 inches diameter with stainless handle | 8 | pc | 3 |
| 12 | Turner | solid, stainless steel, with handy loop for hanging, 12 inches long | 8 | pc | 3 |
| 13 | Spatula | Stainless steel straight blade, 14 inches long with wood handle | 8 | pc | 3 |
| 14 | Wooden Spatula | large comfortable handle, 12 inches long, wooden | 8 | pc | 3 |
| 15 | Piping Bag | 12 inches, light weight, reusable, flexible polyester, coated, can be boiled, dishwasher safe | 8 | pc | 3 |
| 16 | Pastry Tubes | steel stainless, set of 24 pcs, different/assorted icing nozzles medium size, constructed of 18/8 quality stainless steel, comes in plastic storage box with lid | 8 | set | 3 |
| 17 | Strainer, chinois medium | medium, 8 inches diameter, stainless steel including handle | 3 | pc | 3 |
| 18 | Strainer, chinois small | small, 5 inches diameter, stainless steel including handle | 2 | pc | 3 |
| 19 | Funnel | general purpose, hard plastic, comes in 4 different sizes (small, medium, large, extra large) | 4 | set | 3 |
| 20 | Measuring Spoon | Stainless steel 6 pcs/set (1/8 tsp, 1/4 tsp, 1/2 tsp, 1 tsp, 1/2 tbsp, 1 tbsp) | 6 | set | 3 |
| 21 | Food Tong | 12 inches long, stainless steel, and wide shell head with locking | 8 | pc | 3 |
| 22 | Measuring Cup, liquid | glass graduated, 250 ml capacity | 8 | pc | 3 |
| 23 | Ice Cream Scooper | set of three, stainless steel (2 oz, 4 oz and 6 oz) | 2 | set | 3 |

TIN
dy

Procurement of CMU Boxes, Tools and Equipment and Mock-ups for the Mobile Training Laboratories (MTLs).

**TESDA Masbate Provincial Office
Capitol Road, Masbate City**

| NO. | ITEM | AGENCY SPECS | QTY | UNIT | No. Of Box |
|-----|------------------------|--|-----|------|------------|
| 24 | Cheese Cloth | 100% cotton 1 yard | 10 | pc | 3 |
| 25 | Serving Spoon | stainless steel , 9 inches long | 24 | pc | 3 |
| 26 | Pepper and Salt Mill | 2 in 1, wooden, 8" | 4 | pc | 3 |
| 27 | Weighing Scale | analog weighing scale ; maximum weight capacity , 5 kg, graduated by grams , removable and washable tray | 2 | unit | 3 |
| 28 | Weighing Scale | digital, 1000g, maximum weight capacity, battery operated (AAA battery) 0.1 g to 1000g , LCD display battery included. | 2 | unit | 3 |
| 29 | Apple Corer | corer head comfortable on slip handle, corer head is stainless steel | 4 | pc | 3 |
| 30 | Wire Whisk | 8"/20cm, aluminum, balloon style | 8 | pc | 3 |
| 31 | Wire Whisk, medium | medium, 10 inches/25 cm, aluminum, balloon style | 8 | pc | 3 |
| 32 | Wire Whisk, large | heavy duty, stainless steel, 14 inches, balloon style | 2 | pc | 3 |
| 33 | Measuring Cup, dry | stainless steel, 4 pcs/set (1c , 1/2c, 1/3c & 1/4c) | 1 | set | 3 |
| 34 | Chopping Board | 12 x17 inches, polyethylene, easy grip handle, white color | 10 | pc | 3 |
| 35 | Kitchen Scissors | stainless steel blade, size 2 cm x 12 cm x 27 cm, durable and sturdy handle with comfortable grip | 8 | pc | 3 |
| 36 | Soup Ladle | 3 oz capacity, stainless steel, with handle, round bottom | 8 | pc | 3 |
| 37 | Soup Ladle | 6 oz capacity, stainless steel handle, round bottom | 8 | pc | 3 |
| 38 | Soup Ladle | 8 oz capacity, stainless steel handle, round bottom | 3 | pc | 3 |
| 39 | Soup Ladle | 12 oz capacity, stainless handle, round bottom, | 2 | pc | 3 |
| 40 | Mixing Bowl | 12 inches diameter, 8-9 quarts capacity , stainless | 10 | pc | 3 |
| 41 | Kitchen Spoon | solid, stainless steel handle, comfortable non slip handle, round handle 4.5 x2.5 inches | 8 | pc | 3 |
| 42 | Kitchen Spoon | slotted, stainless steel, comfortable non slip handle, round handle 10 x 2.5 inches w/ hole | 8 | pc | 3 |
| 43 | Kitchen Fork | 7.5 cm x 4.5 cm x 37 cm or 10.5 inches, stainless steel, with 2 prongs, round handle | 8 | pc | 3 |
| 44 | Carving Fork | 10.5 inches, stainless steel, with 2 prongs, round handle | 3 | pc | 3 |
| 45 | Pocket Pin Thermometer | analog, temperature range from 0oF to 220 of, dial type | 3 | pc | 3 |
| 46 | Peeler | Straight blade type, dual stainless steel blade, metal handle 5", 2" handle, 3"blade | 8 | pc | 3 |

1
N
91
09

Procurement of CMU Boxes, Tools and Equipment and Mock-ups for the Mobile Training Laboratories (MTLs).

**TESDA Masbate Provincial Office
Capitol Road, Masbate City**

| NO. | ITEM | AGENCY SPECS | QTY | UNIT | No. Of Box |
|-----|---------------------|--|-----|------|------------|
| 47 | Stockpot | stainless, 17 quarts capacity (22.7 lit), 12 inches diameter (30.5 cm), depth 31 cm, 4 mm thickness | 2 | pc | 3 |
| 48 | Frying pan | pan, large, non slick, 26 cm diameter | 2 | pc | 3 |
| 49 | Colander | medium, stainless steel, 8 quarts capacity, with base | 2 | pc | 3 |
| 50 | Fish Poacher | medium, 18 inches (L) and 6 inches(w), stainless steel, with handle | 1 | pc | 3 |
| 51 | Casserole | small, stainless steel, 20 cm diameter, with cover | 8 | pc | 3 |
| 52 | Casserole | medium, stainless steel, 24 cm diameter with cover | 4 | pc | 3 |
| 53 | Double Boiler | medium, made from stainless steel, 2 quarts capacity, with lid cover | 1 | pc | 3 |
| 54 | Paellara | 40 cm diameter, (50 cm with handle), constructed of carbon steel, riveted secure melt handle, safe for all heating surfaces including induction | 4 | pc | 3 |
| 55 | Baking Tray | small, main material is carbon, rectangular, size 14 x 10 inches | 8 | pc | 3 |
| 56 | Utility Tray | hard plastic tray, rectangular 14x18 inches | 12 | pc | 3 |
| 57 | Fire Extinguisher | cylinder type, multipurpose ABC dry chemical, powder aluminum valve coated, rechargeable, 5 lbs capacity, with pressure gauge that allows for immediate pressure status check, with wall hanger, meets requirements for underwriter laboratory (UJ) | 1 | unit | 3 |
| 58 | Blender | 1.5 liter capacity, rated voltage, 230V, 60Hz, power consumption: 300 watts, sharp stainless steel blade, safety lock switch, with plastic stirrer for easy mixing | 1 | unit | 3 |
| 59 | Pressure Cooker | aluminum, 2 mm, 6 quarts capacity, pressured handle, central pressure valve with self locking mechanism | 1 | pc | 3 |
| 60 | Gas Stove with tank | 2 burner, made from stainless top body, automatic ignition, with complete accessories | 4 | unit | 3 |
| 61 | Working Table | high quality stainless steel foldable tables dimension: 3ft x 3ft | 4 | pc | 3 |
| 62 | Kitchen Sink | Kitchen sink, portable single bowl sink stainless steel, with steel collapsible frame legs, with drain hose, Dimension 50cmx50cmx30cm | 1 | unit | 3 |
| 63 | Laptop | 15.6", Core i7, 1.40GHz, wide screen, 1TB hard drive, 8GB DDR3 memory, NVIDIA GTX 670MX graphic processor, 3GB video memory, Gigabit 10/100/1000Mbps IEEE802.11b/g/n Wireless LAN, web camera, HDMI, Bluetooth, USB2.0, USB3.0, with Windows 8 OS, up to 8 hours charge-in-use battery, DVDRW super Multi with 1 year warranty | 1 | unit | 3 |

7
N
96
04

Procurement of CMU Boxes, Tools and Equipment and Mock-ups for the Mobile Training Laboratories (MTLs).

**TESDA Masbate Provincial Office
Capitol Road, Masbate City**

| NO. | ITEM | AGENCY SPECS | QTY | UNIT | No. Of Box |
|--|-----------------------|--|-----|---------|------------|
| 64 | MS Office 2013 | Home & Student 1 user | 1 | unit | 3 |
| 65 | Projector | LCD Projector Portable, RGB liquid crystal shutter projection system (3LCD), White Light Output 2,600 lumens, Colour Light Output 2,600 lumens, XGA Resolution, lightweight: less than 2 kgs. | 1 | unit | 3 |
| 66 | HDMI cable | 3 meters, v1.4A HDMI cable for Projector | 1 | pc | 3 |
| 67 | Whiteboard | wooden whiteboard (2' x 3') with frame, 1 meter collapsible high stand | 1 | pc | 3 |
| 68 | PA System | 550W Portable with Trolley, with 2 wireless mics, 220V, RCA port, with warranty | 1 | unit | 3 |
| 69 | Megaphone | with speak and music switch and volume control, 25w | 1 | unit | 3 |
| 70 | First Aid Kit | First Aid Kit with the contents: betadine, alcohol, adhesive strips, band-aid, disposable gloves, hypoallergenic medical tape (1.25 cm x 9.1m), conforming bandage (5cm), triangular bandage (110m x 110cm), wound dressing no. 15, swab antiseptic, tweezers metal 8 cm, scissors disposable, safety pins assorted (12 pcs), hot and cold compress pack, first aid quick reference guide. | 1 | package | 3 |
| Electrical Installation and Maintenance (EIM) NC II Tools and Equipment (for training purposes) | | | | | |
| 1 | Spirit Level | high impact plastic; magnetic; 3 vials; Length:24" | 1 | pc | 2 |
| 2 | Hacksaw | adjustable hacksaw frame with bi-metal hacksaw blade, 24 TPI, aluminum alloy frame and handle | 5 | pc | 2 |
| 3 | Pipe Cutter | max. capacity 1/8-2 " for steel or ductile iron pipes with steel handle | 2 | pc | 2 |
| 4 | Pipe Reamer | 2 " capacity, ratchet type with steel handle, 1/8-2 " capacity, suitable for use with power drives | 2 | pc | 2 |
| 5 | Pipe Threader | drop head with 3 sets of head and dies, sizes (1/2", 3/4", 1") | 2 | unit | 2 |
| 6 | Pipe Bender | manual, 1/2-3/4 inch bending radius, ductile high strength iron | 2 | unit | 2 |
| 7 | Electricians Plier | overall length 6, knife length: 5/8", material: carbon steel handle finished: plastic dipped | 25 | pc | 2 |
| 8 | Long Nose Plier | dyna grip, 152mm/6" inches carbon steel | 25 | pc | 2 |
| 9 | Phillips Screw Driver | 1x75, PH 2 x 100, PH 2x125 plastic and rubberized handle chrome vanadium, shank 4" | 25 | set | 2 |
| 10 | Flat Screw Driver | 3x75, 5x100, 6x125 plastic and rubberized handle chrome vanadium shank 4" | 25 | set | 2 |
| 11 | Wrench, Combination | 6mm,8mm,10mm,11mm,12mm,13mm,14mm,15mm,16mm,17mm,19mm, 21mm,22mm, 24 mm, chrome vanadium steel | 5 | set | 2 |
| 12 | Wire Stripper | automatic, cap. 1.5mm to 3.5mm | 10 | pc | 2 |
| 13 | Electrician Knife | blade length 3", taper ground cutlery single steel blade, ergonomically designed slip resistant grip | 25 | pc | 2 |

Handwritten initials/signature

Procurement of CMU Boxes, Tools and Equipment and Mock-ups for the Mobile Training Laboratories (MTLs).

**TESDA Masbate Provincial Office
Capitol Road, Masbate City**

| NO. | ITEM | AGENCY SPECS | QTY | UNIT | No. Of Box |
|-----|----------------|---|-----|------|------------|
| 14 | Tool Holster | leather, 3 pocket & 4 holes with belt | 25 | pc | 2 |
| 15 | Pull Push Rule | blade length 8 mtrs, blade width 1", high impact ABS case with durable rubber corrosion resistant Inu-zero end | 25 | pc | 2 |
| 16 | Claw Hammer | 16 oz., forged steel construction, hardened and tempered steel head, smooth face, wooden handle | 10 | pc | 2 |
| 17 | Heat Gun | 1600 watts, 230v, 60 Hz, 12.5 amp. dual temperature, with different nozzle | 2 | unit | 2 |
| 18 | Power Drill | drilling cap.:10mm, cap. wood: 20mm, wattage 350w, no load speed: 0-2500rpm, weight 1.1 kg., Rev.- for rotation, 3/8" capacity. 220VAC, 60Hz | 2 | unit | 2 |
| 19 | Multi-Tester | analog, standard-size analog multimeter for measuring voltage, current, and resistance. An auxiliary connector is also provided for checking transistors. Specifications: -DC Voltage Range: 0 to 1000V in seven ranges -AC Voltage Range: 0 to 1000V in five ranges -DC Current Range: 0 to 250mA in four ranges -Resistance Range: x1 to 20KW in four ranges -Transistor hFE Range: -0 to 1000 -Transistors Leakage Current (ICEO) Range: -0 to 150mAAF Output Range: -10dB to +22dB | 5 | unit | 2 |
| 20 | Clamp Ammeter | digital max. AC voltage measurement 600V, max. AC current measurement 400Aac, max. DC voltage measurement 600Vdc, max. resistance measurement 400ohms, battery type AAA, clamp meter type, continuity current, frequency, resistance, voltage, display type LCD, jaw capacity, bus bars 10x34mm, safety category voltage, 300V, 600V | 2 | unit | 2 |
| 21 | Pipe Vise | capacity 2", material steel, d with swivel base with dual locking nuts, 360 degrees of rotation. | 2 | pc | 2 |
| 22 | Laptop | 15.6", Core i7, 1.40GHz, wide screen, 1TB hard drive, 8GB DDR3 memory, NVIDIA GTX 670MX graphic processor, 3GB video memory, Gigabit 10/100/1000Mbps IEEE802.11b/g/n Wireless LAN, web camera, HDMI, Bluetooth, USB2.0, USB3.0, with Windows 8 OS, up to 6 hours charge-in-use battery, DVDRW super Multi with 1 year warranty | 1 | unit | 2 |
| 23 | MS Office 2013 | Home & Student 1 user | 1 | unit | 2 |
| 24 | Projector | LCD Projector Portable, RGB liquid crystal shutter projection system (3LCD), White Light Output 2,600 lumens, Colour Light Output 2,600 lumens, XGA Resolution, lightweight: less than 2 kgs. | 1 | unit | 2 |
| 25 | HDMI cable | 3 meters, v1.4A HDMI cable for Projector | 1 | pc | 2 |
| 26 | Whiteboard | wooden whiteboard (2' x 3') with frame, 1 meter collapsible high stand | 1 | pc | 2 |
| 27 | PA System | 550W Portable with Trolley, with 2 wireless mics, 220V, RCA port, with warranty | 1 | unit | 2 |
| 28 | Megaphone | with speak and music switch and volume control, 25w | 1 | unit | 2 |

TN 91
as

Procurement of CMU Boxes, Tools and Equipment and Mock-ups for the Mobile Training Laboratories (MTLs).

**TESDA Masbate Provincial Office
Capitol Road, Masbate City**

| NO. | ITEM | AGENCY SPECS | QTY | UNIT | No. Of Box |
|--|-----------------------|--|-----|---------|------------|
| 29 | First Aid Kit | First Aid Kit with the contents: betadine, alcohol, adhesive strips, band-aid, disposable gloves, hypoallergenic medical tape (1.25 cm x 9.1m), conforming bandage (5cm), triangular bandage (110m x 110cm), wound dressing no. 15, swab antiseptic, tweezers metal 8 cm, scissors disposable, safety pins assorted (12 pcs), hot and cold compress pack, first aid quick reference guide. | 1 | package | 2 |
| Food Processing NC II Tools and Equipment (for training purposes) | | | | | |
| 1 | Weighing Scale | Manual weighing scale; maximum weight capacity, 5 kg., graduated by grams, removable and washable tray | 5 | unit | 3 |
| 2 | Weighing Scale | digital, 1000g, maximum weight capacity, battery operated (AAA battery) 0.1 g to 1000g , LCD display battery included. | 5 | unit | 3 |
| 3 | Paring Knives | stainless steel blade, 4 inches | 25 | pc | 3 |
| 4 | Peeler | Straight blade type, dual stainless steel blade, metal handle 5", 2" handle, 3" blade | 12 | pc | 3 |
| 5 | Measuring Spoon | Stainless steel 6 pcs/set (1/8 tsp, 1/4 tsp, 1/2 tsp, 1 tsp 1/2 tsp, 1 tbsp) | 6 | set | 3 |
| 6 | Measuring Cup, dry | stainless steel, 4 pcs/set (1c , 1/2c, 1/3c & 1/4c) | 6 | set | 3 |
| 7 | Measuring Cup, liquid | glass graduated, 250 ml capacity | 6 | pc | 3 |
| 8 | Clocks/Timer | digital, battery operated, with convenient clip, battery included. | 5 | pc | 3 |
| 9 | Mixing Bowl | 12 inches diameter, 8-9 quarts capacity, stainless | 12 | set | 3 |
| 10 | Chopping Board | 12x17 inches, polyethylene, easy grip handle, white color | 3 | set | 3 |
| 11 | Dial Thermometer | stainless steel, 12" stem, stainless clip | 5 | pc | 3 |
| 12 | Osterizers | 8 speed with pulse, 500 watts, 220 volts 60 hertz, stainless steel ice crusher blade, 6 cups glass jar capacity, with warranty. | 4 | unit | 3 |
| 13 | Jar Lifter | non slip handle, rubberized 5" full expansion | 5 | pc | 3 |
| 14 | Food Processors | with exact slice system, 2 in one wide mouth feed tube, with high, low, pulse, off operation, adjustable stainless steel slicing disc and ultra tight seal, 220 volts , 60 hertz, 700 watts | 1 | unit | 3 |
| 15 | Wire Baskets | stainless steel, rectangular, with handle, 4" x 17.75" x 14" (HxWxD) | 5 | pc | 3 |
| 16 | Casseroles | stainless steel, with cover, 5 quarts capacity, with long handles | 5 | pc | 3 |
| 17 | Saucepan | stainless steel, with cover and handle, 26 cm | 5 | pc | 3 |
| 18 | Spoon, wooden | wooden turner; size 12 inches | 15 | pc | 3 |
| 19 | Spoon, basting | 12" long, 100% solid wood, strong and durable. | 15 | pc | 3 |
| 20 | Paddle, wooden | solid wood, 24 inches length x 3-1/2 inches width | 4 | pc | 3 |
| 21 | Food Tong | 12 inches long, stainless steel, and wide shell head with locking | 14 | pc | 3 |
| 22 | Kitchen Scissors | stainless steel blade, size 2 cm x 12 cm x 27 cm, durable and sturdy handle with comfortable grip | 12 | pc | 3 |
| 23 | Steamer | 6 quarts base pan doubles as a stock pot, aluminum, with cover, 3 layer ,30 cm | 4 | pc | 3 |

Procurement of CMU Boxes, Tools and Equipment and Mock-ups for the Mobile Training Laboratories (MTLs).

**TESDA Masbate Provincial Office
Capitol Road, Masbate City**

| NO. | ITEM | AGENCY SPECS | QTY | UNIT | No. Of Box |
|-----|-----------------------------|--|-----|---------|------------|
| 24 | Fermented Containers (pail) | hard plastic, with 16 liter capacity, with cover | 5 | pc | 3 |
| 25 | Utility Tray | hard plastic tray, rectangular 14x18 inches | 20 | pc | 3 |
| 26 | Colander | medium, stainless steel, 8 quarts capacity, with base | 10 | pc | 3 |
| 27 | Smoke House | Width - 25" Height - 40" Length - 15", 3 Layers of Parilya inside, 1" for Tray above the Charcoal, 2" for the box of Charcoal, Gauge of Stainless - 1.0 Mirror | 1 | unit | 3 |
| 28 | Gas Stove with tank | 2 burner, made from stainless top body, automatic ignition, with complete accessories | 3 | unit | 3 |
| 29 | Polytemperature Sealer | 300mm long, 220 volts, 60 Hz, 400W | 2 | unit | 3 |
| 30 | Pressure Canner | 25 quarts, stainless steel | 2 | pc | 3 |
| 31 | Pressure Cooker | 8 quarts, stainless steel | 3 | pc | 3 |
| 32 | Electric Oven | 220 V, 60 Hz., 1000W, 18 L capacity, with warranty | 1 | unit | 3 |
| 33 | Meat Grinder | (size in cm) 49 x 23 x 29.5, stainless main materials, 220 volts, 60 Hz., 1/2 HP, with warranty | 1 | unit | 3 |
| 34 | Casseroles | stainless steel, 10" diameter, with lid | 4 | pc | 3 |
| 35 | Working Table | high quality stainless steel foldable tables dimension: 3ft x 3ft | 4 | pc | 3 |
| 36 | Chef Knife | 8 inch, stainless steel full tang blade with plastic handle | 10 | pc | 3 |
| 37 | Laptop | 15.6", Core i7, 1.40GHz, wide screen, 1TB hard drive, 8GB DDR3 memory, NVIDIA GTX 870MX graphic processor, 3GB video memory, Gigabit 10/100/1000Mbps IEEE802.11b/g/n Wireless LAN, web camera, HDMI, Bluetooth, USB2.0, USB3.0, with Windows 8 OS, up to 6 hours charge-in-use battery, DVDRW super Multi with 1 year warranty | 1 | unit | 3 |
| 38 | MS Office 2013 | Home & Student 1 user | 1 | unit | 3 |
| 39 | Projector | LCD Projector Portable, RGB liquid crystal shutter projection system (3LCD), White Light Output 2,600 lumens, Colour Light Output 2,600 lumens, XGA Resolution, lightweight: less than 2 kgs. | 1 | unit | 3 |
| 40 | HDMI cable | 3 meters, v1.4A HDMI cable for Projector | 1 | pc | 3 |
| 41 | Whiteboard | wooden whiteboard (2' x 3') with frame, 1 meter collapsible high stand | 1 | pc | 3 |
| 42 | PA System | 550W Portable with Trolley, with 2 wireless mics, 220V, RCA port, with warranty | 1 | unit | 3 |
| 43 | Megaphone | with speak and music switch and volume control, 25w | 1 | unit | 3 |
| 44 | First Aid Kit | First Aid Kit with the contents: betadine, alcohol, adhesive strips, band-aid, disposable gloves, hypoallergenic medical tape (1.25 cm x 9.1m), conforming bandage (5cm), triangular bandage (110m x 110cm), wound dressing no. 15, swab antiseptic, tweezers metal 8 cm, scissors disposable, safety pins assorted (12 pcs), hot and cold compress pack, first aid quick reference guide. | 1 | package | 3 |

Small Engine Repair (Motorcycle/Small Engine Servicing NC II) Tools and Equipment (for training purposes)

7 N
of 1

Procurement of CMU Boxes, Tools and Equipment and Mock-ups for the Mobile Training Laboratories (MTLs).

**TESDA Masbate Provincial Office
Capitol Road, Masbate City**

| NO. | ITEM | AGENCY SPECS | QTY | UNIT | No. Of Box |
|-----|----------------------------|---|-----|------|------------|
| 1 | Impact Drive Tool | 4pcs, 1/2" Impact Driver Set, heavy duty. | 10 | set | 4 |
| 2 | Multi-Tester | analog, standard-size analog multimeter for measuring voltage, current, and resistance. An auxiliary connector is also provided for checking transistors. Specifications: •DC Voltage Range: 0 to 1000V in seven ranges •AC Voltage Range: 0 to 1000V in five ranges •DC Current Range: 0 to 250mA in four ranges •Resistance Range: x1 to 20KW in four ranges •Transistor hFE Range: -0 to 1000 •Transistors Leakage Current (ICEO) Range: -0 to 150mAAF Output Range: -10dB to +22dB | 10 | pc | 4 |
| 3 | Oiler | metal case, 1/2 liter cap | 10 | pc | 4 |
| 4 | Steel Brush | wooden handle | 10 | pc | 4 |
| 5 | Hacksaw | adjustable hacksaw frame with bi-metal hacksaw blade, 24 TPI, aluminum alloy frame and handle | 10 | pc | 4 |
| 6 | Center Punch | high speed steel, 5x125 mm | 10 | pc | 4 |
| 7 | Cold Chisel | flat blade, 1" (W), 6" (L), hardened steel | 10 | pc | 4 |
| 8 | Fly Wheel/Magneto Puller | universal type, six in one fly wheel/ magneto puller | 10 | pc | 4 |
| 9 | Oil Seal Remover/Installer | pointed tip, hardened steel w/ straight handle, 3 pcs per set | 10 | set | 4 |
| 10 | Piston Ring Compressor | self locking w/ L wrench steel, range 2 1/8" to 5 inch diameter | 10 | pc | 4 |
| 11 | Valve Spring Compressor | spring loaded offset jaw overhead valve spring compressor, steel | 10 | pc | 4 |
| 12 | Clutch Assembly Remover | universal compressor clutch hub for removal and installation | 10 | pc | 4 |
| 13 | Electricians Plier | overall length 6, knife length: 5/8", material: carbon steel handle finished: plastic dipped | 10 | pc | 4 |
| 14 | Diagonal Cutting Plier | dyna grip, 152mm/6" inches carbon steel | 10 | pc | 4 |
| 15 | Mechanical Plier | 8", insulated handle | 10 | pc | 4 |
| 16 | Vise Gripped Plier | 10R straight jaw | 10 | pc | 4 |
| 17 | Feeler Gauge | 26 blade feeler gauge set, metric & English marked gauge | 10 | pc | 4 |
| 18 | Screwdriver, Flat | 8", magnetic tip, chrome vanadium, plastic handle | 10 | pc | 4 |

Handwritten signature and initials

Procurement of CMU Boxes, Tools and Equipment and Mock-ups for the Mobile Training Laboratories (MTLs).

**TESDA Masbate Provincial Office
Capitol Road, Masbate City**

| NO. | ITEM | AGENCY SPECS | QTY | UNIT | No. Of Box |
|-----|----------------------|--|-----|------|------------|
| 19 | Screwdriver, Philips | 8", magnetic tip, chrome vanadium, plastic handle | 10 | pc | 4 |
| 20 | Ballpeen hammer | 12 oz., 11 1/2" overall length forged steel construction, hardened and tempered, wooden handle | 10 | pc | 4 |
| 21 | Hammer, Brass/copper | 1 lb., wooden handle | 10 | pc | 4 |
| 22 | Hammer, Plastic | 1 lb, wooden handle, plastic tip hammer | 10 | pc | 4 |
| 23 | Wrench, Sparkplug | 19x16 mm, hexagonal w/ handle | 10 | pc | 4 |
| 24 | Wrench, Combination | 6mm,8mm,10mm,11mm,12mm,13mm,14mm,15mm,16mm,17mm,19mm, 21mm,22mm, 24 mm, chrome vanadium steel | 10 | set | 4 |
| 25 | Wrench, Socket | 8 - 32 mm., black, 1/2" drive | 10 | set | 4 |
| 26 | Wrench, T-type | 8, 10, 12, 14 mm | 10 | set | 4 |
| 27 | Hand Tractor Engine | diesel engine, single piston, 4 stroke direct injection, 10-12 hp | 2 | unit | 4 |
| 28 | Laptop | 15.6", Core i7, 1.40GHz, wide screen, 1TB hard drive, 8GB DDR3 memory, NVIDIA GTX 670MX graphic processor, 3GB video memory, Gigabit 10/100/1000Mbps IEEE802.11b/g/n Wireless LAN, web camera, HDMI, Bluetooth, USB2.0, USB3.0, with Windows 8 OS, up to 6 hours charge-in-use battery, DVDRW super Multi with 1 year warranty | 1 | unit | 4 |
| 29 | MS Office 2013 | Home & Student 1 user | 1 | unit | 4 |
| 30 | Projector | LCD Projector Portable, RGB liquid crystal shutter projection system (3LCD), White Light Output 2,600 lumens, Colour Light Output 2,600 lumens, XGA Resolution, lightweight: less than 2 kgs. | 1 | unit | 4 |
| 31 | HDMI cable | 3 meters, v1.4A HDMI cable for Projector | 1 | pc | 4 |
| 32 | Whiteboard | wooden whiteboard (2' x 3') with frame, 1 meter collapsible high stand | 1 | pc | 4 |
| 33 | PA System | 550W Portable with Trolley, with 2 wireless mics, 220V, RCA port, with warranty | 1 | unit | 4 |
| 34 | Megaphone | with speak and music switch and volume control, 25w | 1 | unit | 4 |

T. N. P.
df

Procurement of CMU Boxes, Tools and Equipment and Mock-ups for the Mobile Training Laboratories (MTLs).

**TESDA Masbate Provincial Office
Capitol Road, Masbate City**

| NO. | ITEM | AGENCY SPECS | QTY | UNIT | No. Of Box |
|-----|---------------|--|-----|---------|------------|
| 35 | First Aid Kit | First Aid Kit with the contents: betadine, alcohol, adhesive strips, band-aid, disposable gloves, hypoallergenic medical tape (1.25 cm x 9.1m), conforming bandage (5cm), triangular bandage (110m x 110cm), wound dressing no. 15, swab antiseptic, tweezers metal 8 cm, scissors disposable, safety pins assorted (12 pcs), hot and cold compress pack, first aid quick reference guide. | 1 | package | 4 |

Handwritten initials/signature

Procurement of CMU Boxes, Tools and Equipment and Mock-ups for the Mobile Training Laboratories (MTLs).

**TESDA Masbate Provincial Office
Capitol Road, Masbate City**

| No. | Item / Description | Qty. | Unit | No. of Mock-up |
|--|---|------|-------|----------------|
| Electrical Installation and Maintenance (EIM) NC II Mock-up | | | | |
| 1 | Electrical Installation Maintenance (EIM) Mock-Up | 1 | lot | 1 |
| SUPPLIES AND MATERIALS | | | | |
| 2 | Heat gun, 1200 watts | 1 | pc | 1 |
| 3 | PVC adapter with lock nuts | 20 | pc | 1 |
| 4 | Circuit breaker, 30A | 2 | pc | 1 |
| 5 | 1/2" diameter PVC pipe | 2 | meter | 1 |
| 6 | Cable ties, 100 pcs./pack | 1 | pack | 1 |
| 7 | Incandescent bulb, 220V, 25W | 5 | pc | 1 |
| 8 | One pole switch with plate, flush type | 5 | pc | 1 |
| 9 | Three way switch with plate, flush type | 5 | pc | 1 |
| 10 | Four way switch with plate, flush type | 5 | pc | 1 |
| 11 | Lamp receptacle 4" X 4" surface type | 5 | pc | 1 |
| 12 | Photo electrical (photocell) | 1 | pc | 1 |
| 13 | Convenience outlet, universal type | 5 | pc | 1 |
| 14 | Floor outlet, round type | 1 | pc | 1 |
| 15 | Ground fault current interrupter | 1 | pc | 1 |
| 16 | Circuit breaker 60A with built in housing | 1 | pc | 1 |
| 17 | Terminal block 15A 12 slots | 40 | pc | 1 |
| 18 | Automotive Wire #14 AWG (1 solid and 1 stranded) | 2 | roll | 1 |
| 19 | Terminal lug, Y type | 150 | pc | 1 |
| This include supplies and materials required in the fabrication of mock-up | | | | |
| Small Engine Repair (Motorcycle/Small Engine Servicing NC II) Tools and Equipment Mock-up | | | | |
| 1 | Motorcycle/Small Engine Collapsible Mock-Up | 1 | lot | 1 |
| SUPPLIES AND MATERIALS: | | | | |
| 2 | Auto wire, stranded # 16 | 1 | roll | 1 |
| 3 | Electrical tape, large black | 2 | pc | 1 |
| 4 | Head light assembly, 12 volts rectangular | 1 | pc | 1 |
| 5 | signal light assembly, 12 volts | 2 | pair | 1 |
| 6 | Horn, 12 volts | 1 | pc | 1 |
| 7 | Stop light switch, push button | 1 | pc | 1 |
| 8 | Signal light switch, double throw, toggle switch | 1 | pc | 1 |
| 9 | Ignition switch, gas engine type | 1 | pc | 1 |
| 10 | Signal light relay, 12 volts | 1 | pc | 1 |
| 11 | Push button switch for horn | 1 | pc | 1 |

12
pb
atj

Procurement of CMU Boxes, Tools and Equipment and Mock-ups for the Mobile Training Laboratories (MTLs).

**TESDA Masbate Provincial Office
Capitol Road, Masbate City**

| No. | Item / Description | Qty. | Unit | No. of Mock-up |
|--|---|------|-------|----------------|
| 12 | Motorcycle storage battery, 12 volts maintenance free | 1 | pc | 1 |
| 13 | Harness cover, 3/8" diameter (140/4) | 4 | meter | 1 |
| 14 | Harness connector, 6 terminals | 4 | pc | 1 |
| 15 | Male terminal, flat | 30 | pc | 1 |
| 16 | Female terminal, flat | 30 | pc | 1 |
| 17 | Headlight switch or toggle switch, single throw | 1 | pc | 1 |
| 18 | Crocodile clip, medium, red and black | 1 | pair | 1 |
| 19 | 3/16" diameter X 3/4" stove bolt, stainless | 20 | pc | 1 |
| 20 | 3/16" diameter hole, eye terminal | 10 | pc | 1 |
| 21 | Four stroke motorcycle engine, 125 or 155cc, surplus | 1 | unit | 1 |
| This include supplies and materials required in the fabrication of mock-up | | | | |

T.M.
96

Procurement of CMU Boxes, Tools and Equipment and Mock-ups for the Mobile Training Laboratories (MTLs).

**TESDA Eastern Samar Provincial Office
Borongan, Eastern Samar**

| NO. | ITEM | AGENCY SPECS | QTY | UNIT | No. Of Box |
|---|--|---|-----|------|------------|
| Appliance Repair NC II Tools and Equipment (for training purposes) | | | | | |
| 1 | Soldering Iron | dual wattage, 25 watts/ 120watts, 220 volt 60 Hz, with long life tip, "gun type" | 25 | unit | 3 |
| 2 | Desoldering Tools | desoldering pump with precision regulated return, replacement tip compact, metal housing | 25 | unit | 3 |
| 3 | Screw driver assorted (Phillips and slotted) | 12x7x1 inches, 6 pieces per set, plastic handle | 5 | set | 3 |
| 4 | Long Nose Plier | dyna grip, 152mm/6" inches carbon steel | 5 | pc | 3 |
| 5 | Diagonal Cutting Plier | dyna grip, 152mm/6" inches carbon steel | 5 | pc | 3 |
| 6 | Nut Drivers | rust-resistant, nickel-plated bar, hexagonal shank, includes: 5mm, 6mm, 7mm, 8mm, 9mm, 10mm, 11mm | 5 | set | 3 |
| 7 | Wrench, Combination | 6mm,8mm,10mm,11mm,12mm,13mm,14mm,15mm, 16mm,17mm,19mm, 21mm,22mm, 24 mm, chrome vanadium steel | 5 | set | 3 |
| 8 | Wire Stripper | automatic, cap. 1.5mm to 3.5mm | 10 | pc | 3 |
| 9 | Ballpeen hammer | 12 oz., 11 1/2" overall length forged steel construction, hardened and tempered, wooden handle | 5 | pc | 3 |
| 10 | Flashlight | LED, 3 volts/6 volts, rechargeable | 5 | pc | 3 |
| 11 | Detector Light | test light, 220 volts | 5 | pc | 3 |
| 12 | Paint Brush | 4 inches width, wooden handle | 25 | pc | 3 |
| 13 | Microwave Oven | power capacity: 220V 1300 watts, interior capacity 20 liters, 8 programmes, defrost option, 26cm diameter rotating turntable, digital | 1 | unit | 3 |
| 14 | Washing Machine with dryer | power capacity: 500w, 220V, rust proof body, gear drive system, dolphin drive pulsator, washing capacity (dry weight) 7.5kg, spinning capacity (dry weight) 5.5kg, width should be more than 50 cm and length of not more than 100 cm | 1 | unit | 3 |
| 15 | Electric Fan | power capacity: 220V, 100w, 60Hz, 3 speed rotary switch, 18 inch metal blade, round/stable plastic base, thermal fuse protection, adjustable height stand fan | 1 | unit | 3 |
| 16 | Electric Rice Cooker | power capacity: 700w, 220V, 60Hz, automatic cooking feature, auto shutoff, glass lid, non-stick coated aluminum pan, includes measuring cup and rice scoop | 1 | unit | 3 |

TN
of

Procurement of CMU Boxes, Tools and Equipment and Mock-ups for the Mobile Training Laboratories (MTLs).

**TESDA Eastern Samar Provincial Office
Borongan, Eastern Samar**

| NO. | ITEM | AGENCY SPECS | QTY | UNIT | No. Of Box |
|-----|--------------------|--|-----|------|------------|
| 17 | Electric Flat Iron | power capacity:1000w, 220V, 60 Hz, non-stick Teflon soleplate, thermal fuse protected, variable temperature control, automatic thermostat Control, pilot lamp indicator | 1 | unit | 3 |
| 18 | Coffee Maker | power capacity: 550w, 220V, 60Hz, glass pitcher, anti-drip feature, 6 cup water capacity, water level indicator, swing-out filter basket | 1 | unit | 3 |
| 19 | Oven Toaster | power capacity: 1000w, 220V, 60Hz, stainless steel, 8 liter capacity, 15 minute timer, slide out chrome crumb rack, includes baking tray | 1 | unit | 3 |
| 20 | Blender | 1.5 liter capacity, rated voltage, 230V, 60Hz, power consumption: 300 watts, sharp stainless steel blade, safety lock switch, with plastic stirrer for easy mixing | 1 | unit | 3 |
| 21 | Multi Tester | analog, standard size analog multimeter for measuring voltage, current and resistance. An auxiliary connector is also provided for checking transistors. SPECIFICATION: <ul style="list-style-type: none"> •DC Voltage Range: 0 to 1000V in seven ranges •AC Voltage Range: 0 to 1000V in five ranges •DC Current Range: 0 to 250mA in four ranges •Resistance Range: x1 to 200MEG in four ranges •Transistor hFE Range: -0 to 1000 •Transistors Leakage Current (ICEO) Range: -0 to 150mAAF •Output Range: -10dB to +22dB | 25 | unit | 3 |
| 22 | Multi Tester | Digital Multi meters are standard digital multimeter for measuring voltage, current, and resistance with 3-1/2 digit LCD display. This meter measures only 138mm x 70mm x 32mm and weighs approximately 140 grams, including battery. SPECIFICATION: <ul style="list-style-type: none"> •DC Voltage Range: 200mV to 600V in five ranges (auto ranging) •AC Voltage Range: 2V to 600V in four ranges (auto ranging) •DC Current Range: 200mA to 10A in six ranges •Resistance Range: 200 Ohms to 20M in six ranges •Transistor hFE Test Range: 0 to 2000 | 25 | unit | 3 |
| 23 | Laptop | 15.6", Core i7, 1.40GHz, wide screen, 1TB hard drive, 8GB DDR3 memory, NVIDIA GTX 670MX graphic processor, 3GB video memory, Gigabit 10/100/1000Mbps IEEE802.11b/g/n Wireless LAN, web camera, HDMI, Bluetooth, USB2.0, USB3.0, with Windows 8 OS, up to 6 hours charge-in-use battery, DVDRW super Multl with 1 year warranty | 1 | unit | 3 |

Handwritten signature and initials

Procurement of CMU Boxes, Tools and Equipment and Mock-ups for the Mobile Training Laboratories (MTLs).

**TESDA Eastern Samar Provincial Office
Borongan, Eastern Samar**

| NO. | ITEM | AGENCY SPECS | QTY | UNIT | No. Of Box |
|---|-----------------------|--|-----|---------|------------|
| 24 | MS Office 2013 | Home & Student 1 user | 1 | unit | 3 |
| 25 | Projector | LCD Projector Portable, RGB liquid crystal shutter projection system (3LCD), White Light Output 2,600 lumens, Colour Light Output 2,600 lumens, XGA Resolution, lightweight: less than 2 kgs. | 1 | unit | 3 |
| 26 | HDMI cable | 3 meters, v1.4A HDMI cable for Projector | 1 | pc | 3 |
| 27 | Whiteboard | wooden whiteboard (2' x 3') with frame, 1 meter collapsible high stand | 1 | pc | 3 |
| 28 | PA System | 550W Portable with Trolley, with 2 wireless mics, 220V, RCA port, with warranty | 1 | unit | 3 |
| 29 | Megaphone | with speak and music switch and volume control, 25w | 1 | unit | 3 |
| 30 | First Aid Kit | First Aid Kit with the contents: betadine, alcohol, adhesive strips, band-aid, disposable gloves, hypoallergenic medical tape (1.25 cm x 9.1m), conforming bandage (5cm), triangular bandage (110m x 110cm), wound dressing no. 15, swab antiseptic, tweezers metal 8 cm, scissors disposable, safety pins assorted (12 pcs), hot and cold compress pack, first aid quick reference guide. | 1 | package | 3 |
| Bread and Pastry NC II Tools and Equipment (for training purposes) | | | | | |
| 1 | Measuring Cup, dry | stainless steel, 4 pcs/set (1c, 1/2c, 1/3c & 1/4c) | 12 | pc | 3 |
| 2 | Measuring Cup, liquid | glass graduated, 250 ml capacity | 12 | pc | 3 |
| 3 | Measuring Spoon | Stainless steel 6 pcs/set(1/8 tsp, 1/4 tsp, 1/2tsp, 1 tsp 1/2 tbsp, 1 tbsp) | 12 | set | 3 |
| 4 | Cake Turn Table | plastic cake turntable with locking switch, rubberized feet, white, 12.6x12.6x3.54 inches (LxWxH) | 10 | pc | 3 |
| 5 | Decorating Tips | stainless steel, 24-piece cake decorating tip set, package size: 17cm x 12cm x 5cm (6.69 x 4.72 x 1.97inches) | 25 | set | 3 |
| 6 | Rolling Pin | wooden, size 33.5 x 5cm, light weight comfortable grip | 25 | pc | 3 |
| 7 | Pie Plate, size 6" | aluminum pie pan, 6" diameter x 5/8 in deep, heavy weight round pan | 10 | pc | 3 |
| 8 | Pie Plate, size 8" | pie pan, 8" aluminum deep dish pie pan, standard weight aluminum, 8" top outside diameter | 10 | pc | 3 |
| 9 | Pie Plate, size 10" | deep aluminum pie pan, 10" diameter, depth 1-1/4", made of 0.7mm thick satin finished aluminum | 10 | pc | 3 |
| 10 | Jelly Roll Pan | aluminum, dimension: 2" x 13 x 8' (HxWxD) | 10 | pc | 3 |

Procurement of CMU Boxes, Tools and Equipment and Mock-ups for the Mobile Training Laboratories (MTLs).

**TESDA Eastern Samar Provincial Office
Borongan, Eastern Samar**

| NO. | ITEM | AGENCY SPECS | QTY | UNIT | No. Of Box |
|-----|----------------------|--|-----|------|------------|
| 11 | Cake Spring Form Pan | heavy aluminum spring form pan, heavy duty frame, spring form sides for easy removal, size 9 x 3" | 10 | pc | 3 |
| 12 | Pie Cutter | triple riveted pizza cutter, made of stainless steel, rolling wheel slicer, 6" | 10 | pc | 3 |
| 13 | Rubber Scraper | rubber head, high heat resistant, flexible, 12", color white | 25 | pc | 3 |
| 14 | Spatula | Stainless steel straight blade, 14 inches long with wood handle | 25 | pc | 3 |
| 15 | Cake Stand with tier | 3 tier cake round acrylic cake stand, 3 plates clear, size: 15cm, 20cm, 25cm, 10 inches gap between each tier | 6 | set | 3 |
| 16 | Saucepan | Stainless steel with cover and handle 26cm | 15 | pc | 3 |
| 17 | Ladle | stainless steel, 12 inches, comes with brush finished handle, hole in the handle for easy hanging | 10 | pc | 3 |
| 18 | Chef Knife | 8 inch, stainless steel full tang blade with plastic handle | 12 | pc | 3 |
| 19 | Chopping Board | 12 x 17 inches, polyethylene, easy grip handle, white color | 10 | pc | 3 |
| 20 | Weighing Scale | manual, maximum weight capacity 2kg, graduated by grams, removable and washable tray | 6 | pc | 3 |
| 21 | Grater | made of nonreactive stainless steel easy grip handle | 10 | pc | 3 |
| 22 | Wooden Spoon | wooden turner, size 12 inches | 25 | pc | 3 |
| 23 | Piping Bag | 12 inches, light weight, reusable, flexible polyester, coated can be boiled, dishwasher safe | 25 | pc | 3 |
| 24 | Mixing Bowl | 12 inches diameter, 8-9 quarts capacity, stainless | 15 | pc | 3 |
| 25 | Wire Whisk | 8"/20cm, aluminum, balloon style | 25 | pc | 3 |
| 26 | Electric Mixer | 4 qt. stainless steel bowl, 5 speeds & quick burst button, bowl rest TM mixer stabilizer, doubles as a hand mixer, 220V, 290-watts peak power, versatile attachment set includes traditional beaters, whisk and dough hooks, brushed stainless steel | 5 | unit | 3 |
| 27 | Dough Cutter | dough scraper 6" wide x 4", high polished stainless steel blade | 10 | pc | 3 |
| 28 | Oven (gas) | stainless door, 2 trays oven with tempered glass window, 22-25" collapsible stand | 1 | unit | 3 |
| 29 | Pastry Brush | pastry/basting brush, natural wood handle brushes, 1.5" size | 10 | pc | 3 |
| 30 | Bread Knife | 8", serrated edge stain free high-carbon steel blade texture red polypropylene handle | 10 | pc | 3 |

JW
af 96

Procurement of CMU Boxes, Tools and Equipment and Mock-ups for the Mobile Training Laboratories (MTLs).

**TESDA Eastern Samar Provincial Office
Borongan, Eastern Samar**

| NO. | ITEM | AGENCY SPECS | QTY | UNIT | No. Of Box |
|--|---------------------|--|-----|---------|------------|
| 31 | Flour Sifter | stainless steel mesh flour sifter strainer, 12" | 10 | pc | 3 |
| 32 | Baking Sheet | aluminum, 13" x 18" | 15 | pc | 3 |
| 33 | Muffin Pans | 12 holes, 3 oz. capacity per holes, aluminum | 25 | pc | 3 |
| 34 | Working Table | high quality stainless steel foldable tables dimension: 3ft x 3ft | 4 | pc | 3 |
| 35 | Gas Stove with tank | 2 burner, made from stainless top body, automatic ignition, with complete accessories | 2 | pc | 3 |
| 36 | Kitchen Sink | Kitchen sink, portable single bowl sink stainless steel, with steel collapsible frame legs, with drain hose, Dimension 50cmx50cmx30cm | 1 | pc | 3 |
| 37 | Weighing Scale | digital, 1000g, maximum weight capacity, battery operated (AAA battery) 0.1 g to 1000g, LCD display battery included. | 5 | pc | 3 |
| 38 | Laptop | 15.6", Core i7, 1.40GHz, wide screen, 1TB hard drive, 8GB DDR3 memory, NVIDIA GTX 670MX graphic processor, 3GB video memory, Gigabit 10/100/1000Mbps IEEE802.11b/g/n Wireless LAN, web camera, HDMI, Bluetooth, USB2.0, USB3.0, with Windows 8 OS, up to 6 hours charge-in-use battery, DVDRW super Multi with 1 year warranty | 1 | unit | 3 |
| 39 | MS Office 2013 | Home & Student 1 user | 1 | unit | 3 |
| 40 | Projector | LCD Projector Portable, RGB liquid crystal shutter projection system (3LCD), White Light Output 2,600 lumens, Colour Light Output 2,600 lumens, XGA Resolution, lightweight: less than 2 kgs. | 1 | unit | 3 |
| 41 | HDMI cable | 3 meters, v1.4A HDMI cable for Projector | 1 | pc | 3 |
| 42 | Whiteboard | wooden whiteboard (2' x 3') with frame, 1 meter collapsible high stand | 1 | pc | 3 |
| 43 | PA System | 550W Portable with Trolley, with 2 wireless mics, 220V, RCA port, with warranty | 1 | unit | 3 |
| 44 | Megaphone | with speak and music switch and volume control, 25w | 1 | unit | 3 |
| 45 | First Aid Kit | First Aid Kit with the contents: betadine, alcohol, adhesive strips, band-aid, disposable gloves, hypoallergenic medical tape (1.25 cm x 9.1m), conforming bandage (5cm), triangular bandage (110m x 110cm), wound dressing no. 15, swab antiseptic, tweezers metal 8 cm, scissors disposable, safety pins assorted (12 pcs), hot and cold compress pack, first aid quick reference guide. | 1 | package | 3 |
| Electrical Installation and Maintenance (EIM) NC II Tools and Equipment (for training purposes) | | | | | |
| 1 | Spirit Level | high impact plastic; magnetic; 3 vials; Length:24" | 1 | pc | 2 |
| 2 | Hacksaw | adjustable hacksaw frame with bi-metal hacksaw blade, 24 TPI, aluminum alloy frame and handle | 5 | pc | 2 |

Handwritten signature/initials

Procurement of CMU Boxes, Tools and Equipment and Mock-ups for the Mobile Training Laboratories (MTLs).

**TESDA Eastern Samar Provincial Office
Borongan, Eastern Samar**

| NO. | ITEM | AGENCY SPECS | QTY | UNIT | No. Of Box |
|-----|-----------------------|--|-----|------|------------|
| 3 | Pipe Cutter | max. capacity 1/8-2 " for steel or ductile iron pipes with steel handle | 2 | pc | 2 |
| 4 | Pipe Reamer | 2 " capacity, ratchet type with steel handle, 1/8-2 " capacity, suitable for use with power drives | 2 | pc | 2 |
| 5 | Pipe Threader | drop head with 3 sets of head and dies, sizes (1/2",3/4",1") | 2 | unit | 2 |
| 6 | Pipe Bender | manual, 1/2-3/4 inch bending radius, ductile high strength iron | 2 | unit | 2 |
| 7 | Electricians Plier | overall length 6, knife length: 5/8", material: carbon steel handle finished: plastic dipped | 25 | pc | 2 |
| 8 | Long Nose Plier | dyna grip, 152mm/6" inches carbon steel | 25 | pc | 2 |
| 9 | Phillips Screw Driver | 1x75, PH 2 x 100, PH 2x125 plastic and rubberized handle chrome vanadium, shank 4" | 25 | set | 2 |
| 10 | Flat Screw Driver | 3x75, 5x100, 6x125 plastic and rubberized handle chrome vanadium shank 4" | 25 | set | 2 |
| 11 | Wrench, Combination | 6mm,8mm,10mm,11mm,12mm,13mm,14mm,15mm, 16mm,17mm,19mm, 21mm,22mm, 24 mm, chrome vanadium steel | 5 | set | 2 |
| 12 | Wire Stripper | automatic, cap. 1.5mm to 3.5mm | 10 | pc | 2 |
| 13 | Electrician Knife | blade length 3", taper ground cutlery single steel blade, ergonomically designed slip resistant grip | 25 | pc | 2 |
| 14 | Tool Holster | leather, 3 pocket & 4 holes with belt | 25 | pc | 2 |
| 15 | Pull Push Rule | blade length 8 mtrs, blade width 1", high impact ABS case with durable rubber corrosion resistant lru-zero end | 25 | pc | 2 |
| 16 | Claw Hammer | 16 oz., forged steel construction, hardened and tempered steel head, smooth face, wooden handle | 10 | pc | 2 |
| 17 | Heat Gun | 1600 watts, 230v, 60 Hz, 12.5 amp. dual temperature, with different nozzle | 2 | unit | 2 |
| 18 | Power Drill | drilling cap.:10mm, cap. wood: 20mm, wattage 350w, no load speed: 0-2500rpm, weight 1.1 kg., Rev.- for rotation, 3/8" capacity. 220VAC, 60Hz | 2 | unit | 2 |
| 19 | Multi-Tester | analog, standard-size analog multimeter for measuring voltage, current, and resistance. An auxiliary connector is also provided for checking transistors. Specifications: •DC Voltage Range: 0 to 1000V in seven ranges •AC Voltage Range: 0 to 1000V in five ranges •DC Current Range: 0 to 250mA in four ranges •Resistance Range: x1 to 20KW in four ranges •Transistor hFE Range: -0 to 1000 -Transistors Leakage Current (ICEO) Range: -0 to 150mAAF Output Range: -10dB to +22dB | 5 | unit | 2 |
| 20 | Clamp Ammeter | digital max. AC voltage measurement 600V, max. AC current measurement 400Aac, max. DC voltage measurement 600Vdc, max. resistance measurement 400ohms, battery type AAA, clamp meter type, continuity current, frequency, resistance, voltage, display type LCD, jaw capacity, bus bars 10x34mm, safety category voltage, 300V, 600V | 2 | unit | 2 |
| 21 | Pipe Vise | capacity 2", material steel, d with swivel base with dual locking nuts, 360 degrees of rotation. | 2 | pc | 2 |

Procurement of CMU Boxes, Tools and Equipment and Mock-ups for the Mobile Training Laboratories (MTLs).

**TESDA Eastern Samar Provincial Office
Borongan, Eastern Samar**

| NO. | ITEM | AGENCY SPECS | QTY | UNIT | No. Of Box |
|--|-----------------------|--|-----|---------|------------|
| 22 | Laptop | 15.6", Core i7, 1.40GHz, wide screen, 1TB hard drive, 8GB DDR3 memory, NVIDIA GTX 670MX graphic processor, 3GB video memory, Gigabit 10/100/1000Mbps IEEE802.11b/g/n Wireless LAN, web camera, HDMI, Bluetooth, USB2.0, USB3.0, with Windows 8 OS, up to 6 hours charge-in-use battery, DVDRW super Multi with 1 year warranty | 1 | unit | 2 |
| 23 | MS Office 2013 | Home & Student 1 user | 1 | unit | 2 |
| 24 | Projector | LCD Projector Portable, RGB liquid crystal shutter projection system (3LCD), White Light Output 2,600 lumens, Colour Light Output 2,600 lumens, XGA Resolution, lightweight: less than 2 kgs. | 1 | unit | 2 |
| 25 | HDMI cable | 3 meters, v1.4A HDMI cable for Projector | 1 | pc | 2 |
| 26 | Whiteboard | wooden whiteboard (2' x 3') with frame, 1 meter collapsible high stand | 1 | pc | 2 |
| 27 | PA System | 550W Portable with Trolley, with 2 wireless mics, 220V, RCA port, with warranty | 1 | unit | 2 |
| 28 | Megaphone | with speak and music switch and volume control, 25w | 1 | unit | 2 |
| 29 | First Aid Kit | First Aid Kit with the contents: betadine, alcohol, adhesive strips, band-aid, disposable gloves, hypoallergenic medical tape (1.25 cm x 9.1m), conforming bandage (5cm), triangular bandage (110m x 110cm), wound dressing no. 15, swab antiseptic, tweezers metal 8 cm, scissors disposable, safety pins assorted (12 pcs), hot and cold compress pack, first aid quick reference guide. | 1 | package | 2 |
| Food Processing NC II Tools and Equipment (for training purposes) | | | | | |
| 1 | Weighing Scale | Manual weighing scale; maximum weight capacity, 5 kg., graduated by grams, removable and washable tray | 5 | unit | 3 |
| 2 | Weighing Scale | digital, 1000g, maximum weight capacity, battery operated (AAA battery) 0.1 g to 1000g , LCD display battery included. | 5 | unit | 3 |
| 3 | Paring Knives | stainless steel blade, 4 Inches | 25 | pc | 3 |
| 4 | Peeler | Straight blade type, dual stainless steel blade, metal handle 5", 2" handle, 3" blade | 12 | pc | 3 |
| 5 | Measuring Spoon | Stainless steel 6 pcs/set (1/8 tsp, 1/4 tsp, 1/2tsp, 1 tsp 1/2 tbsp, 1 tbsp) | 6 | set | 3 |
| 6 | Measuring Cup, dry | stainless steel, 4 pcs/set (1c , 1/2c, 1/3c & 1/4c) | 6 | set | 3 |
| 7 | Measuring Cup, liquid | glass graduated, 250 ml capacity | 6 | pc | 3 |
| 8 | Clocks/Timer | digital, battery operated, with convenient clip, battery included. | 5 | pc | 3 |
| 9 | Mixing Bowl | 12 inches diameter, 8-9 quarts capacity , stainless | 12 | set | 3 |
| 10 | Chopping Board | 12x17 inches, polyethylene, easy grip handle, white color | 3 | set | 3 |
| 11 | Dial Thermometer | stainless steel, 12" stem, stainless clip | 5 | pc | 3 |
| 12 | Osterizers | 8 speed with pulse, 500 watts, 220 volts 60 hertz, stainless steel ice crusher blade, 6 cups glass jar capacity, with warranty. | 4 | unit | 3 |
| 13 | Jar Lifter | non slip handle, rubberized 5" full expansion | 5 | pc | 3 |

Handwritten signature and initials

Procurement of CMU Boxes, Tools and Equipment and Mock-ups for the Mobile Training Laboratories (MTLs).

**TESDA Eastern Samar Provincial Office
Borongan, Eastern Samar**

| NO. | ITEM | AGENCY SPECS | QTY | UNIT | No. Of Box |
|-----|-----------------------------|--|-----|------|------------|
| 14 | Food Processors | with exact slice system, 2 in one wide mouth feed tube, with high, low, pulse, off operation, adjustable stainless steel slicing disc and ultra tight seal, 220 volts, 60 hertz, 700 watts | 1 | unit | 3 |
| 15 | Wire Baskets | stainless steel, rectangular, with handle, 4" x 17.75" x 14" (HxWxD) | 5 | pc | 3 |
| 16 | Casserole | stainless steel, with cover, 5 quarts capacity, with long handles | 5 | pc | 3 |
| 17 | Saucepan | stainless steel, with cover and handle, 26 cm | 5 | pc | 3 |
| 18 | Spoon, wooden | wooden turner, size 12 inches | 15 | pc | 3 |
| 19 | Spoon, basting | 12" long, 100% solid wood, strong and durable. | 15 | pc | 3 |
| 20 | Paddle, wooden | solid wood, 24 inches length x 3-1/2 inches width | 4 | pc | 3 |
| 21 | Food Tong | 12 inches long, stainless steel, and wide shell head with locking | 14 | pc | 3 |
| 22 | Kitchen Scissors | stainless steel blade, size 2 cm x 12 cm x 27 cm, durable and sturdy handle with comfortable grip | 12 | pc | 3 |
| 23 | Steamer | 6 quarts base pan doubles as a stock pot, aluminum, with cover, 3 layer, 30 cm | 4 | pc | 3 |
| 24 | Fermented Containers (pail) | hard plastic, with 16 liter capacity, with cover | 5 | pc | 3 |
| 25 | Utility Tray | hard plastic tray, rectangular 14x18 inches | 20 | pc | 3 |
| 26 | Colander | medium, stainless steel, 8 quarts capacity, with base | 10 | pc | 3 |
| 27 | Smoke House | Width - 25" Height - 40" Length - 15", 3 Layers of Parilya inside, 1" for Tray above the Charcoal, 2" for the box of Charcoal, Gauge of Stainless - 1.0 Mirror | 1 | unit | 3 |
| 28 | Gas Stove with tank | 2 burner, made from stainless top body, automatic ignition, with complete accessories | 3 | unit | 3 |
| 29 | Polytemperature Sealer | 300mm long, 220 volts, 60 Hz, 400W | 2 | unit | 3 |
| 30 | Pressure Canner | 25 quarts, stainless steel | 2 | pc | 3 |
| 31 | Pressure Cooker | 8 quarts, stainless steel | 3 | pc | 3 |
| 32 | Electric Oven | 220 V, 60 Hz., 1000W, 18 L capacity, with warranty | 1 | unit | 3 |
| 33 | Meat Grinder | (size in cm) 49 x 23 x 29.5, stainless main materials, 220 volts, 60 Hz., 1/2 HP, with warranty | 1 | unit | 3 |
| 34 | Casserole | stainless steel, 10" diameter, with lid | 4 | pc | 3 |
| 35 | Working Table | high quality stainless steel foldable tables dimension: 3ft x 3ft | 4 | pc | 3 |
| 36 | Chef Knife | 8 inch, stainless steel full tang blade with plastic handle | 10 | pc | 3 |
| 37 | Laptop | 15.6", Core i7, 1.40GHz, wide screen, 1TB hard drive, 8GB DDR3 memory, NVIDIA GTX 670MX graphic processor, 3GB video memory, Gigabit 10/100/1000Mbps IEEE802.11b/g/n Wireless LAN, web camera, HDMI, Bluetooth, USB2.0, USB3.0, with Windows 8 OS, up to 6 hours charge-in-use battery, DVDRW super Multi with 1 year warranty | 1 | unit | 3 |
| 38 | MS Office 2013 | Home & Student 1 user | 1 | unit | 3 |
| 39 | Projector | LCD Projector Portable, RGB liquid crystal shutter projection system (3LCD), White Light Output 2,600 lumens, Colour Light Output 2,600 lumens, XGA Resolution, lightweight: less than 2 kgs. | 1 | unit | 3 |
| 40 | HDMI cable | 3 meters, v1.4A HDMI cable for Projector | 1 | pc | 3 |

Handwritten initials/signature

Procurement of CMU Boxes, Tools and Equipment and Mock-ups for the Mobile Training Laboratories (MTLs).

**TESDA Eastern Samar Provincial Office
Borongan, Eastern Samar**

| NO. | ITEM | AGENCY SPECS | QTY | UNIT | No. Of Box |
|---|-------------------------------|--|-----|---------|------------|
| 41 | Whiteboard | wooden whiteboard (2' x 3') with frame, 1 meter collapsible high stand | 1 | pc | 3 |
| 42 | PA System | 550W Portable with Trolley, with 2 wireless mics, 220V, RCA port, with warranty | 1 | unit | 3 |
| 43 | Megaphone | with speak and music switch and volume control, 25w | 1 | unit | 3 |
| 44 | First Aid Kit | First Aid Kit with the contents: betadine, alcohol, adhesive strips, band-aid, disposable gloves, hypoallergenic medical tape (1.25 cm x 9.1m), conforming bandage (5cm), triangular bandage (110m x 110cm), wound dressing no. 15, swab antiseptic, tweezers metal 8 cm, scissors disposable, safety pins assorted (12 pcs), hot and cold compress pack, first aid quick reference guide. | 1 | package | 3 |
| Plumbing NC II Tools and Equipment (for training purposes) | | | | | |
| 1 | Pipe Wrench | 12" straight, heavy duty, forged alloy steel 12", pipe capacity 2" or 50mm, weight 1.2 kg. cast-iron housing and I-beam handle with full floating forged hook jaw, featuring self cleaning threads with replaceable hook and heel jaws | 5 | pc | 3 |
| 2 | Pipe Wrench | 14" straight, heavy duty, forged alloy steel 12", pipe capacity 2" or 50mm, weight 1.6 kg. cast-iron housing and I-beam handle with full floating forged hook jaw, featuring self cleaning threads with replaceable hook and heel jaws | 5 | pc | 3 |
| 3 | Pull Push Rule | blade length 8 mtrs, blade width 1", high impact ABS case with durable rubber corrosion resistant Iru-zero end | 10 | pc | 3 |
| 4 | Hacksaw | adjustable hacksaw frame with bi-metal hacksaw blade, 24 TPI, aluminum alloy frame and handle | 5 | pc | 3 |
| 5 | Spirit Level | high impact plastic; magnetic; 3 vials; Length:24" | 5 | pc | 3 |
| 6 | Pipe Reamer | 2 " capacity, ratchet type with steel handle, 1/8-2 " capacity, suitable for use with power drives | 5 | pc | 3 |
| 7 | Pipe Cutter | max. capacity 1/8-2 " for steel or ductile iron pipes with steel handle | 5 | pc | 3 |
| 8 | Adjustable Wrench | alloy steel, 0 - 2 " jaw opening, 10" length | 5 | pc | 3 |
| 9 | Mechanical Plier | mechanical, plastic dipped insulated handle, 6 " length, rust-resistant chrome finish, two position adjustable joint pliers | 5 | pc | 3 |
| 10 | Pipe Vise | capacity 2", material steel, d with swivel base with dual locking nuts, 360 degrees of rotation. | 2 | pc | 3 |
| 11 | Pipe Threader | drop head with 3 sets of head and dies, sizes (1/2", 3/4", 1") | 2 | pc | 3 |
| 12 | Portable Tri-stand Chain Vise | 1/8 to 6 in., rear pipe support, rugged tool tray capacity: 1/8" - 6", leg locking: over center tool tray | 3 | pc | 3 |
| 13 | Manual Pressure Test Pump | 6 mpa, 860 psi max. pressure, 12 L. capacity, with brass pump valve | 1 | pc | 3 |
| 14 | Socket Fusion Machine | 20 mm - 32 mm cap. 3/4", 1", 1-1/4" and 1-1/2", 220V, 1600w | 2 | pc | 3 |
| 15 | Ballpeen hammer | 12 oz., 11 1/2" overall length forged steel construction, hardened and tempered, wooden handle | 5 | pc | 3 |

Procurement of CMU Boxes, Tools and Equipment and Mock-ups for the Mobile Training Laboratories (MTLs).

**TESDA Eastern Samar Provincial Office
Borongan, Eastern Samar**

| NO. | ITEM | AGENCY SPECS | QTY | UNIT | No. Of Box |
|-----|---------------------------|--|-----|------|------------|
| 16 | Angle Grinder | 4 "diameter, wheel cap, 220V, 60 Hz, single phase, 11,000 rpm, all-ball bearing design and metal gear | 2 | pc | 3 |
| 17 | Electric Portable Drill | 1/2 " bit jaw capacity, 220V, single phase, variable speed (0-550 rpm), heavy duty, 1/2" drill chuck | 1 | pc | 3 |
| 18 | Carpenter Steel Square | high tempered aluminum steel, 2" x 16" x 24", 5-60 and 30-degree angle markings, high tempered aluminum for maximum durability, 1/8-inch graduations for long-term visibility, body: 24 by 2-inches, tongue: 16 by 1-1/2" | 4 | pc | 3 |
| 19 | Claw Hammer | 16 oz., forged steel construction, hardened and tempered steel head, smooth face, wooden handle | 5 | pc | 3 |
| 20 | Paint Brush | 1/2" round trim brush soft bristle, tin-plated ferrules | 10 | pc | 3 |
| 21 | Hand Gloves | 5 finger, poly/cotton blend with a latex coated palm | 25 | pc | 3 |
| 22 | Safety Hard Hat | V-rib, yellow ball-cap style hard hat with 6 point ratchet-type headgear, 2 point chin strap and V rib on top, polyethylene material | 25 | pc | 3 |
| 23 | Safety Shoes | heavy duty steel toe cap, waterproof, anti static (sizes 40-42) lts anti-static and heat resistant (up to 300 degree C/572 degree F) with TPU SAFETY cell construction steel toe cap | 25 | pc | 3 |
| 24 | Safety Goggles | clear polycarbonate, woven elastic strap (adjustable) | 25 | pc | 3 |
| 25 | Water Meter | multi jet plastic meter, 1/2" NPT, 20 gpm, brass body | 1 | pc | 3 |
| 26 | Water Closet | flush type, ceramic, dimension (LxWxH): 684x430x787 mm, flushing action: siphonic, single/dual flush: single flush, flush Volume: 6L, flushing activation: front lever, rough-in: 305mm, discharge: floor cover | 1 | pc | 3 |
| 27 | Lavatory with Faucet | center hole, with mixing hot and cold faucet, ceramic, wall hung type, wall hung sink, 4-inch center faucet holes, front overflow, self-draining deck area with contoured back and side splash shields | 2 | pc | 3 |
| 28 | Kitchen Sink with Faucet | stainless steel, rust and heat resistant, grade 304, 74 cm x 51.5 cm, 16.2 mm outlet hole | 1 | pc | 3 |
| 29 | Single Point Water Heater | 4.5kw, 220V, 60 Hz, 2 psi min water pressure, 55 psi, 2 L/min minimum water flow, 1/2" BSP | 2 | pc | 3 |
| 30 | Laptop | 15.6", Core i7, 1.40GHz, wide screen, 1TB hard drive, 8GB DDR3 memory, NVIDIA GTX 670MX graphic processor, 3GB video memory, Gigabit 10/100/1000Mbps IEEE802.11b/g/n Wireless LAN, web camera, HDMI, Bluetooth, USB2.0, USB3.0, with Windows 8 OS, up to 6 hours charge-in-use battery, DVDRW super Multi with 1 year warranty | 1 | unit | 3 |
| 31 | MS Office 2013 | Home & Student 1 user | 1 | unit | 3 |
| 32 | Projector | LCD Projector Portable, RGB liquid crystal shutter projection system (3LCD), White Light Output 2,600 lumens, Colour Light Output 2,600 lumens, XGA Resolution, lightweight: less than 2 kgs. | 1 | unit | 3 |
| 33 | HDMI cable | 3 meters, v1.4A HDMI cable for Projector | 1 | pc | 3 |

2
1/2
1/2

Procurement of CMU Boxes, Tools and Equipment and Mock-ups for the Mobile Training Laboratories (MTLs).

**TESDA Eastern Samar Provincial Office
Borongan, Eastern Samar**

| NO. | ITEM | AGENCY SPECS | QTY | UNIT | No. Of Box |
|--|----------------------------|--|-----|---------|------------|
| 34 | Whiteboard | wooden whiteboard (2' x 3') with frame, 1 meter collapsible high stand | 1 | pc | 3 |
| 35 | PA System | 550W Portable with Trolley, with 2 wireless mics, 220V, RCA port, with warranty | 1 | unit | 3 |
| 36 | Megaphone | with speak and music switch and volume control, 25w | 1 | unit | 3 |
| 37 | First Aid Kit | First Aid Kit with the contents: betadine, alcohol, adhesive strips, band-aid, disposable gloves, hypoallergenic medical tape (1.25 cm x 9.1m), conforming bandage (5cm), triangular bandage (110m x 110cm), wound dressing no. 15, swab antiseptic, tweezers metal 8 cm, scissors disposable, safety pins assorted (12 pcs), hot and cold compress pack, first aid quick reference guide. | 1 | package | 3 |
| Small Engine Repair (Motorcycle/Small Engine Servicing NC II) Tools and Equipment (for training purposes) | | | | | |
| 1 | Impact Drive Tool | 4pcs, 1/2" Impact Driver Set, heavy duty. | 10 | set | 4 |
| 2 | Multi-Tester | analog, standard-size analog multimeter for measuring voltage, current, and resistance. An auxiliary connector is also provided for checking transistors. Specifications: •DC Voltage Range: 0 to 1000V in seven ranges •AC Voltage Range: 0 to 1000V in five ranges •DC Current Range: 0 to 250mA in four ranges •Resistance Range: x1 to 20KW in four ranges •Transistor hFE Range: -0 to 1000 •Transistors Leakage Current (ICEO) Range: -0 to 150mAAF Output Range: -10dB to +22dB | 10 | pc | 4 |
| 3 | Oiler | metal case, 1/2 liter cap | 10 | pc | 4 |
| 4 | Steel Brush | wooden handle | 10 | pc | 4 |
| 5 | Hacksaw | adjustable hacksaw frame with bi-metal hacksaw blade, 24 TPI, aluminum alloy frame and handle | 10 | pc | 4 |
| 6 | Center Punch | high speed steel, 5x125 mm | 10 | pc | 4 |
| 7 | Cold Chisel | flat blade, 1" (W), 6" (L), hardened steel | 10 | pc | 4 |
| 8 | Fly Wheel/Magneto Puller | universal type, six in one fly wheel/ magneto puller | 10 | pc | 4 |
| 9 | Oil Seal Remover/Installer | pointed tip, hardened steel w/ straight handle, 3 pcs per set | 10 | set | 4 |
| 10 | Piston Ring Compressor | self locking w/ L wrench steel, range 2 1/8" to 5 inch diameter | 10 | pc | 4 |
| 11 | Valve Spring Compressor | spring loaded offset jaw overhead valve spring compressor, steel | 10 | pc | 4 |
| 12 | Clutch Assembly Remover | universal compressor clutch hub for removal and installation | 10 | pc | 4 |

Procurement of CMU Boxes, Tools and Equipment and Mock-ups for the Mobile Training Laboratories (MTLs).

**TESDA Eastern Samar Provincial Office
Borongan, Eastern Samar**

| NO. | ITEM | AGENCY SPECS | QTY | UNIT | No. Of Box |
|-----|------------------------|--|-----|------|------------|
| 13 | Electricians Plier | overall length 6, knife length: 5/8", material: carbon steel handle finished: plastic dipped | 10 | pc | 4 |
| 14 | Diagonal Cutting Plier | dyna grip, 152mm/6" inches carbon steel | 10 | pc | 4 |
| 15 | Mechanical Plier | 8", insulated handle | 10 | pc | 4 |
| 16 | Vise Gripped Plier | 10R straight jaw | 10 | pc | 4 |
| 17 | Feeler Gauge | 26 blade feeler gauge set, metric & English marked gauge | 10 | pc | 4 |
| 18 | Screwdriver, Flat | 8", magnetic tip, chrome vanadium, plastic handle | 10 | pc | 4 |
| 19 | Screwdriver, Philips | 8", magnetic tip, chrome vanadium, plastic handle | 10 | pc | 4 |
| 20 | Ballpeen hammer | 12 oz., 11 1/2" overall length forged steel construction, hardened and tempered, wooden handle | 10 | pc | 4 |
| 21 | Hammer, Brass/copper | 1 lb., wooden handle | 10 | pc | 4 |
| 22 | Hammer, Plastic | 1 lb, wooden handle, plastic tip hammer | 10 | pc | 4 |
| 23 | Wrench, Sparkplug | 19x16 mm, hexagonal w/ handle | 10 | pc | 4 |
| 24 | Wrench, Combination | 6mm,8mm,10mm,11mm,12mm,13mm,14mm,15mm,16mm,17mm,19mm, 21mm,22mm, 24 mm, chrome vanadium steel | 10 | set | 4 |
| 25 | Wrench, Socket | 8 - 32 mm., black, 1/2" drive | 10 | set | 4 |
| 26 | Wrench, T-type | 8, 10, 12, 14 mm | 10 | set | 4 |
| 27 | Hand Tractor Engine | diesel engine, single piston, 4 stroke direct injection, 10-12 hp | 2 | unit | 4 |
| 28 | Laptop | 15.6". Core i7, 1.40GHz, wide screen, 1TB hard drive, 8GB DDR3 memory, NVIDIA GTX 670MX graphic processor, 3GB video memory, Gigabit 10/100/1000Mbps IEEE802.11b/g/n Wireless LAN, web camera, HDMI, Bluetooth, USB2.0, USB3.0, with Windows 8 OS, up to 6 hours charge-in-use battery, DVDRW super Multi with 1 year warranty | 1 | unit | 4 |
| 29 | MS Office 2013 | Home & Student 1 user | 1 | unit | 4 |

Procurement of CMU Boxes, Tools and Equipment and Mock-ups for the Mobile Training Laboratories (MTLs).

**TESDA Eastern Samar Provincial Office
Borongan, Eastern Samar**

| NO. | ITEM | AGENCY SPECS | QTY | UNIT | No. Of Box |
|-----|---------------|--|-----|---------|------------|
| 30 | Projector | LCD Projector Portable, RGB liquid crystal shutter projection system (3LCD), White Light Output 2,600 lumens, Colour Light Output 2,600 lumens, XGA Resolution, lightweight: less than 2 kgs. | 1 | unit | 4 |
| 31 | HDMI cable | 3 meters, v1.4A HDMI cable for Projector | 1 | pc | 4 |
| 32 | Whiteboard | wooden whiteboard (2' x 3') with frame, 1 meter collapsible high stand | 1 | pc | 4 |
| 33 | PA System | 550W Portable with Trolley, with 2 wireless mics, 220V, RCA port, with warranty | 1 | unit | 4 |
| 34 | Megaphone | with speak and music switch and volume control, 25w | 1 | unit | 4 |
| 35 | First Aid Kit | First Aid Kit with the contents: betadine, alcohol, adhesive strips, band-aid, disposable gloves, hypoallergenic medical tape (1.25 cm x 9.1m), conforming bandage (5cm), triangular bandage (110m x 110cm), wound dressing no. 15, swab antiseptic, tweezers metal 8 cm, scissors disposable, safety pins assorted (12 pcs), hot and cold compress pack, first aid quick reference guide. | 1 | package | 4 |

Handwritten signature/initials

**Procurement of CMU Boxes, Tools and Equipment and Mock-ups for
the Mobile Training Laboratories (MTLs).**

**TESDA Eastern Samar Provincial Office
Borongan, Eastern Samar**

| Lot No. | Item / Description | Qty. | Unit | No. of Mock-up |
|--|---|------|-------|----------------|
| Electrical Installation and Maintenance (EIM) NC II Mock-up | | | | |
| 1 | Electrical Installation Maintenance (EIM) Mock-Up | 1 | lot | 1 |
| SUPPLIES AND MATERIALS | | | | |
| 2 | Heat gun, 1200 watts | 1 | pc | 1 |
| 3 | PVC adapter with lock nuts | 20 | pc | 1 |
| 4 | Circuit breaker, 30A | 2 | pc | 1 |
| 5 | 1/2" diameter PVC pipe | 2 | meter | 1 |
| 6 | Cable ties, 100 pcs./pack | 1 | pack | 1 |
| 7 | Incandescent bulb, 220V, 25W | 5 | pc | 1 |
| 8 | One pole switch with plate, flush type | 5 | pc | 1 |
| 9 | Three way switch with plate, flush type | 5 | pc | 1 |
| 10 | Four way switch with plate, flush type | 5 | pc | 1 |
| 11 | Lamp receptacle 4" X 4" surface type | 5 | pc | 1 |
| 12 | Photo electrical (photo cell) | 1 | pc | 1 |
| 13 | Convenience outlet, universal type | 5 | pc | 1 |
| 14 | Floor outlet, round type | 1 | pc | 1 |
| 15 | Ground fault current interrupter | 1 | pc | 1 |
| 16 | Circuit breaker 60A with built in housing | 1 | pc | 1 |
| 17 | Terminal block 15A 12 slots | 40 | pc | 1 |
| 18 | Automotive Wire #14 AWG (1 solid and 1 stranded) | 2 | roll | 1 |
| 19 | Terminal lug, Y type | 150 | pc | 1 |
| This include supplies and materials required in the fabrication of mock-up | | | | |
| Plumbing NC II Mock-up | | | | |
| 1 | Plumbing Mock-up (Labor Cost) | 1 | lot | 1 |
| SUPPLIES AND MATERIALS | | | | |
| 2 | 4" dia PVC Pipe (Orange) | 1 | pc | 1 |
| 3 | 4" dia. PVC Elbow 90 deg. | 1 | pc | 1 |
| 4 | 4" dia. PVC Elbow 45 deg. | 1 | pc | 1 |
| 5 | 4" dia. PVC Clean Out | 1 | pc | 1 |
| 6 | 4" x 3" PVC Wye | 1 | pc | 1 |
| 7 | 4" x 2" PVC Wye | 3 | pc | 1 |
| 8 | 3" dia. PVC pipe | 1 | pc | 1 |
| 9 | 3" PVC Elbow | 1 | pc | 1 |
| 10 | 3" PVC Elbow 45 deg. | 1 | pc | 1 |
| 11 | 3" x 2" PVC Tee | 1 | pc | 1 |
| 12 | 3" x 3" PVC Tee | 1 | pc | 1 |
| 13 | 2" dia PVC Pipe | 2 | pc | 1 |
| 14 | 2" dia. PVC Elbow 45 deg. | 3 | pc | 1 |
| 15 | 2" dia. PVC Elbow 90 deg. | 3 | pc | 1 |
| 16 | 2" PVC Tee | 4 | pc | 1 |
| 17 | 2" PVC P-trap | 2 | pc | 1 |
| 18 | 1/2" dia. PPr pipe | 2 | pc | 1 |
| 19 | 1/2" dia. PPr elbow | 7 | pc | 1 |
| 20 | 1/2" dia. PPr tee | 4 | pc | 1 |
| 21 | 1/2" dia. PPr elbow connector | 6 | pc | 1 |
| 22 | 1/2" dia. PPr male connector | 2 | pc | 1 |
| 23 | 1/2" dia. PPr union | 3 | pc | 1 |
| 24 | 1/2" dia. PPr coupling | 4 | pc | 1 |

2
1
9/

**Procurement of CMU Boxes, Tools and Equipment and Mock-ups for
the Mobile Training Laboratories (MTLs).**

**TESDA Eastern Samar Provincial Office
Borongan, Eastern Samar**

| Lot No. | Item / Description | Qty. | Unit | No. of Mock-up |
|--|--|------|-------|----------------|
| 25 | Urinal 480mm X 730mm X 730mm with complete accessories | 1 | unit | 1 |
| 26 | Shower head with complete accessories | 1 | unit | 1 |
| 27 | 1/2 x 7/8 flexible hose | 1 | pc | 1 |
| 28 | 1/2 x 1/2" angle valve | 3 | pc | 1 |
| 29 | 3/4" x 4' x 8' Marine Plywood | 1 | pc | 1 |
| 30 | 2" x 2" x 12' Lumber | 4 | pc | 1 |
| 31 | Teflon Tape | 10 | pc | 1 |
| 32 | Metal hinges 2" X 4", heavy duty | 3 | pc | 1 |
| This include supplies and materials required in the fabrication of mock-up | | | | |
| Small Engine Repair (Motorcycle/Small Engine Servicing NC II) Tools and Equipment Mock-up | | | | |
| 1 | Motorcycle/Small Engine Collapsible Mock-Up | 1 | lot | 1 |
| SUPPLIES AND MATERIALS: | | | | |
| 2 | Auto wire, stranded # 16 | 1 | roll | 1 |
| 3 | Electrical tape, large black | 2 | pc | 1 |
| 4 | Head light assembly, 12 volts rectangular | 1 | pc | 1 |
| 5 | signal light assembly, 12 volts | 2 | pair | 1 |
| 6 | Horn, 12 volts | 1 | pc | 1 |
| 7 | Stop light switch, push button | 1 | pc | 1 |
| 8 | Signal light switch, double throw, toggle switch | 1 | pc | 1 |
| 9 | Ignition switch, gas engine type | 1 | pc | 1 |
| 10 | Signal light relay, 12 volts | 1 | pc | 1 |
| 11 | Push button switch for horn | 1 | pc | 1 |
| 12 | Motorcycle storage battery, 12 volts maintenance free | 1 | pc | 1 |
| 13 | Harness cover, 3/8" diameter (140/4) | 4 | meter | 1 |
| 14 | Harness connector, 6 terminals | 4 | pc | 1 |
| 15 | Male terminal, flat | 30 | pc | 1 |
| 16 | Female terminal, flat | 30 | pc | 1 |
| 17 | Headlight switch or toggle switch, single throw | 1 | pc | 1 |
| 18 | Crocodile clip, medium, red and black | 1 | pair | 1 |
| 19 | 3/16" diameter X 3/4" stove bolt, stainless | 20 | pc | 1 |
| 20 | 3/16" diameter hole, eye terminal | 10 | pc | 1 |
| 21 | Four stroke motorcycle engine, 125 or 155cc, surplus | 1 | unit | 1 |
| This include supplies and materials required in the fabrication of mock-up | | | | |

7/2
OK 9/1

Procurement of CMU Boxes, Tools and Equipment and Mock-ups for the Mobile Training Laboratories (MTLs).

**TESDA Northern Samar Provincial Office
UEP Compound, Catarman, Northern Samar**

| NO. | ITEM | AGENCY SPECS | QTY | UNIT | No. Of Box |
|---|--|---|-----|------|------------|
| Appliance Repair NC II Tools and Equipment (for training purposes) | | | | | |
| 1 | Soldering Iron | dual wattage, 25 watts/ 120watts, 220 volt 60 Hz, with long life tip, "gun type" | 25 | unit | 3 |
| 2 | Desoldering Tools | desoldering pump with precision regulated return, replacement tip compact, metal housing | 25 | unit | 3 |
| 3 | Screw driver assorted (Phillips and slotted) | 12x7x1 inches, 6 pieces per set, plastic handle | 5 | set | 3 |
| 4 | Long Nose Plier | dyna grip, 152mm/6" inches carbon steel | 5 | pc | 3 |
| 5 | Diagonal Cutting Plier | dyna grip, 152mm/6" inches carbon steel | 5 | pc | 3 |
| 6 | Nut Drivers | rust-resistant, nickel-plated bar, hexagonal shank, includes: 5mm, 6mm, 7mm, 8mm, 9mm, 10mm, 11mm | 5 | set | 3 |
| 7 | Wrench, Combination | 6mm,8mm,10mm,11mm,12mm,13mm,14mm,15mm, 16mm,17mm,19mm, 21mm,22mm, 24 mm, chrome vanadium steel | 5 | set | 3 |
| 8 | Wire Stripper | automatic, cap. 1.5mm to 3.5mm | 10 | pc | 3 |
| 9 | Ballpeen hammer | 12 oz., 11 1/2" overall length forged steel construction, hardened and tempered, wooden handle | 5 | pc | 3 |
| 10 | Flashlight | LED, 3 volts/6 volts, rechargeable | 5 | pc | 3 |
| 11 | Detector Light | test light, 220 volts | 5 | pc | 3 |
| 12 | Paint Brush | 4 inches width, wooden handle | 25 | pc | 3 |
| 13 | Microwave Oven | power capacity: 220V 1300 watts, interior capacity 20 liters, 8 programmes, defrost option, 26cm diameter rotating turntable, digital | 1 | unit | 3 |
| 14 | Washing Machine with dryer | power capacity: 500w, 220V, rust proof body, gear drive system, dolphin drive pulsator, washing capacity (dry weight) 7.5kg, spinning capacity (dry weight) 5.5kg, width should be more than 50 cm and length of not more than 100 cm | 1 | unit | 3 |
| 15 | Electric Fan | power capacity: 220V, 100w, 60Hz, 3 speed rotary switch, 18 inch metal blade, round/stable plastic base, thermal fuse protection, adjustable height stand fan | 1 | unit | 3 |
| 16 | Electric Rice Cooker | power capacity: 700w, 220V, 60Hz, automatic cooking feature, auto shutoff, glass lid, non-stick coated aluminum pan, includes measuring cup and rice scoop | 1 | unit | 3 |
| 17 | Electric Flat Iron | power capacity:1000w, 220V, 60 Hz, non-stick Teflon soleplate, thermal fuse protected, variable temperature control, automatic thermostat Control, pilot lamp indicator | 1 | unit | 3 |

TN
OK

Procurement of CMU Boxes, Tools and Equipment and Mock-ups for the Mobile Training Laboratories (MTLs).

**TESDA Northern Samar Provincial Office
UEP Compound, Catarman, Northern Samar**

| NO. | ITEM | AGENCY SPECS | QTY | UNIT | No. Of Box |
|-----|--------------------|---|-----|------|------------|
| 17 | Electric Flat Iron | power capacity:1000w, 220V, 60 Hz, non-stick Teflon soleplate, thermal fuse protected, variable temperature control, automatic thermostat Control, pilot lamp indicator | 1 | unit | 3 |
| 18 | Coffee Maker | power capacity: 550w, 220V, 60Hz, glass pitcher, anti-drip feature, 6 cup water capacity, water level indicator, swing-out filter basket | 1 | unit | 3 |
| 19 | Oven Toaster | power capacity: 1000w, 220V, 60Hz, stainless steel, 8 liter capacity, 15 minute timer, slide out chrome crumb rack, includes baking tray | 1 | unit | 3 |
| 20 | Blender | 1.5 liter capacity, rated voltage, 230V, 60Hz, power consumption: 300 watts, sharp stainless steel blade, safety lock switch, with plastic stirrer for easy mixing | 1 | unit | 3 |
| 21 | Multi Tester | analog, standard size analog multimeter for measuring voltage, current and resistance. An auxiliary connector is also provided for checking transistors. SPECIFICATION: •DC Voltage Range: 0 to 1000V in seven ranges •AC Voltage Range: 0 to 1000V in five ranges •DC Current Range: 0 to 250mA in four ranges •Resistance Range: x1 to 200MEG in four ranges •Transistor hFE Range: -0 to 1000 •Transistors Leakage Current (ICEO) Range: -0 to 150mAAF Output Range: -10dB to +22dB | 25 | unit | 3 |
| 22 | Multi Tester | Digital Multi meters are standard digital multimeter for measuring voltage, current, and resistance with 3-1/2 digit LCD display. This meter measures only 138mm x 70mm x 32mm and weighs approximately 140 grams, including battery. SPECIFICATION: •DC Voltage Range: 200mV to 600V in five ranges (auto ranging) •AC Voltage Range: 2V to 600V in four ranges (auto ranging) •DC Current Range: 200mA to 10A in six ranges •Resistance Range: 200 Ohms to 20M In six ranges Transistor hFE Test Range: 0 to 2000 | 25 | unit | 3 |
| 23 | Laptop | 15.6", Core i7, 1.40GHz, wide screen, 1TB hard drive, 8GB DDR3 memory, NVIDIA GTX 670MX graphic processor, 3GB video memory, Gigabit 10/100/1000Mbps IEEE802.11b/g/n Wireless LAN, web camera, HDMI, Bluetooth, USB2.0, USB3.0, with Windows 8 OS, up to 6 hours charge-in-use battery, DVDRW super Multi with 1 year warranty | 1 | unit | 3 |

Handwritten signature and initials in the bottom right corner of the page.

Procurement of CMU Boxes, Tools and Equipment and Mock-ups for the Mobile Training Laboratories (MTLs).

**TESDA Northern Samar Provincial Office
UEP Compound, Catarman, Northern Samar**

| NO. | ITEM | AGENCY SPECS | QTY | UNIT | No. Of Box |
|---|-----------------------|--|-----|---------|------------|
| 24 | MS Office 2013 | Home & Student 1 user | 1 | unit | 3 |
| 25 | Projector | LCD Projector Portable, RGB liquid crystal shutter projection system (3LCD), White Light Output 2,600 lumens, Colour Light Output 2,600 lumens, XGA Resolution, lightweight: less than 2 kgs. | 1 | unit | 3 |
| 26 | HDMI cable | 3 meters, v1.4A HDMI cable for Projector | 1 | pc | 3 |
| 27 | Whiteboard | wooden whiteboard (2' x 3') with frame, 1 meter collapsible high stand | 1 | pc | 3 |
| 28 | PA System | 550W Portable with Trolley, with 2 wireless mics, 220V, RCA port, with warranty | 1 | unit | 3 |
| 29 | Megaphone | with speak and music switch and volume control, 25w | 1 | unit | 3 |
| 30 | First Aid Kit | First Aid Kit with the contents: betadine, alcohol, adhesive strips, band-aid, disposable gloves, hypoallergenic medical tape (1.25 cm x 9.1m), conforming bandage (5cm), triangular bandage (110m x 110cm), wound dressing no. 15, swab antiseptic, tweezers metal 8 cm, scissors disposable, safety pins assorted (12 pcs), hot and cold compress pack, first aid quick reference guide. | 1 | package | 3 |
| Bread and Pastry NC II Tools and Equipment (for training purposes) | | | | | |
| 1 | Measuring Cup, dry | stainless steel, 4 pcs/set (1c, 1/2c, 1/3c & 1/4c) | 12 | pc | 3 |
| 2 | Measuring Cup, liquid | glass graduated, 250 ml capacity | 12 | pc | 3 |
| 3 | Measuring Spoon | Stainless steel 6 pcs/set(1/8 tsp, 1/4 tsp, 1/2tsp, 1 tsp 1/2 tbsp, 1 tbsp) | 12 | set | 3 |
| 4 | Cake Turn Table | plastic cake turntable with locking switch, rubberized feet, white, 12.6x12.6x3.54 inches (LxWxD) | 10 | pc | 3 |
| 5 | Decorating Tips | stainless steel, 24-piece cake decorating tip set, package size: 17cm x 12cm x 5cm (6.69 x 4.72 x 1.97inches) | 25 | set | 3 |
| 6 | Rolling Pin | wooden, size 33.5 x 5cm, light weight comfortable grip | 25 | pc | 3 |
| 7 | Pie Plate, size 6" | aluminum pie pan, 6" diameter x 5/8 in deep, heavy weight round pan | 10 | pc | 3 |
| 8 | Pie Plate, size 8" | pie pan, 8" aluminum deep dish pie pan, standard weight aluminum, 8" top outside diameter | 10 | pc | 3 |
| 9 | Pie Plate, size 10" | deep aluminum pie pan, 10" diameter, depth 1-1/4", made of 0.7mm thick satin finished aluminum | 10 | pc | 3 |
| 10 | Jelly Roll Pan | aluminum, dimension: 2" x 13 x 8" (HxWxD) | 10 | pc | 3 |

*T
N
off*

Procurement of CMU Boxes, Tools and Equipment and Mock-ups for the Mobile Training Laboratories (MTLs).

**TESDA Northern Samar Provincial Office
UEP Compound, Catarman, Northern Samar**

| NO. | ITEM | AGENCY SPECS | QTY | UNIT | No. Of Box |
|-----|----------------------|--|-----|------|------------|
| 11 | Cake Spring Form Pan | heavy aluminum spring form pan, heavy duty frame, spring form sides for easy removal, size 9 x 3" | 10 | pc | 3 |
| 12 | Pie Cutter | triple riveted pizza cutter, made of stainless steel, rolling wheel slicer, 6" | 10 | pc | 3 |
| 13 | Rubber Scraper | rubber head, high heat resistant, flexible, 12", color white | 25 | pc | 3 |
| 14 | Spatula | Stainless steel straight blade, 14 inches long with wood handle | 25 | pc | 3 |
| 15 | Cake Stand with tier | 3 tier cake round acrylic cake stand, 3 plates clear, size: 15cm, 20cm, 25cm, 10 inches gap between each tier | 6 | set | 3 |
| 16 | Saucepan | Stainless steel with cover and handle 26cm | 15 | pc | 3 |
| 17 | Ladle | stainless steel, 12 inches, comes with brush finished handle, hole in the handle for easy hanging | 10 | pc | 3 |
| 18 | Chef Knife | 8 inch, stainless steel full tang blade with plastic handle | 12 | pc | 3 |
| 19 | Chopping Board | 12 x 17 inches, polyethylene, easy grip handle, white color | 10 | pc | 3 |
| 20 | Weighing Scale | manual, maximum weight capacity 2kg, graduated by grams, removable and washable tray | 6 | pc | 3 |
| 21 | Grater | made of nonreactive stainless steel easy grip handle | 10 | pc | 3 |
| 22 | Wooden Spoon | wooden turner, size 12 inches | 25 | pc | 3 |
| 23 | Piping Bag | 12 inches, light weight, reusable, flexible polyester, coated can be boiled, dishwasher safe | 25 | pc | 3 |
| 24 | Mixing Bowl | 12 inches diameter, 8-9 quarts capacity, stainless | 15 | pc | 3 |
| 25 | Wire Whisk | 8"/20cm, aluminum, balloon style | 25 | pc | 3 |
| 26 | Electric Mixer | 4 qt. stainless steel bowl, 5 speeds & quick burst button, bowl rest TM mixer stabilizer, doubles as a hand mixer, 220V, 290-watts peak power, versatile attachment set includes traditional beaters, whisk and dough hooks, brushed stainless steel | 5 | unit | 3 |
| 27 | Dough Cutter | dough scraper 6" wide x 4", high polished stainless steel blade | 10 | pc | 3 |
| 28 | Oven (gas) | stainless door, 2 trays oven with tempered glass window, 22-25" collapsible stand | 1 | unit | 3 |
| 29 | Pastry Brush | pastry/basting brush, natural wood handle brushes, 1.5" size | 10 | pc | 3 |
| 30 | Bread Knife | 8", serrated edge stain free high-carbon steel blade texture red polypropylene handle | 10 | pc | 3 |

Handwritten signature/initials

Procurement of CMU Boxes, Tools and Equipment and Mock-ups for the Mobile Training Laboratories (MTLs).

**TESDA Northern Samar Provincial Office
UEP Compound, Catarman, Northern Samar**

| NO. | ITEM | AGENCY SPECS | QTY | UNIT | No. Of Box |
|--|---------------------|--|-----|---------|------------|
| 31 | Flour Sifter | stainless steel mesh flour sifter strainer, 12" | 10 | pc | 3 |
| 32 | Baking Sheet | aluminum, 13" x 18" | 15 | pc | 3 |
| 33 | Muffin Pans | 12 holes, 3 oz. capacity per holes, aluminum | 25 | pc | 3 |
| 34 | Working Table | high quality stainless steel foldable tables dimension: 3ft x 3ft | 4 | pc | 3 |
| 35 | Gas Stove with tank | 2 burner, made from stainless top body, automatic ignition, with complete accessories | 2 | pc | 3 |
| 36 | Kitchen Sink | Kitchen sink, portable single bowl sink stainless steel, with steel collapsible frame legs, with drain hose, Dimension 50cmx50cmx30cm | 1 | pc | 3 |
| 37 | Weighing Scale | digital, 1000g, maximum weight capacity, battery operated (AAA battery) 0.1 g to 1000g, LCD display battery included. | 5 | pc | 3 |
| 38 | Laptop | 15.6", Core i7, 1.40GHz, wide screen, 1TB hard drive, 8GB DDR3 memory, NVIDIA GTX 670MX graphic processor, 3GB video memory, Gigabit 10/100/1000Mbps IEEE802.11b/g/n Wireless LAN, web camera, HDMI, Bluetooth, USB2.0, USB3.0, with Windows 8 OS, up to 6 hours charge-in-use battery, DVDRW super Multi with 1 year warranty | 1 | unit | 3 |
| 39 | MS Office 2013 | Home & Student 1 user | 1 | unit | 3 |
| 40 | Projector | LCD Projector Portable, RGB liquid crystal shutter projection system (3LCD), White Light Output 2,600 lumens, Colour Light Output 2,600 lumens, XGA Resolution, lightweight: less than 2 kgs. | 1 | unit | 3 |
| 41 | HDMI cable | 3 meters, v1.4A HDMI cable for Projector | 1 | pc | 3 |
| 42 | Whiteboard | wooden whiteboard (2' x 3') with frame, 1 meter collapsible high stand | 1 | pc | 3 |
| 43 | PA System | 550W Portable with Trolley, with 2 wireless mics, 220V, RCA port, with warranty | 1 | unit | 3 |
| 44 | Megaphone | with speak and music switch and volume control, 25w | 1 | unit | 3 |
| 45 | First Aid Kit | First Aid Kit with the contents: betadine, alcohol, adhesive strips, band-aid, disposable gloves, hypoallergenic medical tape (1.25 cm x 9.1m), conforming bandage (5cm), triangular bandage (110m x 110cm), wound dressing no. 15, swab antiseptic, tweezers metal 8 cm, scissors disposable, safety pins assorted (12 pcs), hot and cold compress pack, first aid quick reference guide. | 1 | package | 3 |
| Cookery NC II Tools and Equipment (for training purposes) | | | | | |
| 1 | Chef Knife | 8 inch, stainless steel full tang blade with plastic handle | 10 | pc | 3 |

Handwritten signature/initials

Procurement of CMU Boxes, Tools and Equipment and Mock-ups for the Mobile Training Laboratories (MTLs).

**TESDA Northern Samar Provincial Office
UEP Compound, Catarman, Northern Samar**

| NO. | ITEM | AGENCY SPECS | QTY | UNIT | No. Of Box |
|-----|--------------------------|--|-----|------|------------|
| 2 | Boning Knife | 6 inches, stainless steel with sharp cutting edge with plastic handle | 8 | pc | 3 |
| 3 | Oyster Knife | 7 inches length (3 inches blade and 4 inches handle), stainless steel blade, with comfortable plastic handle | 4 | pc | 3 |
| 4 | Cleaver Knife | 7 inches, stain resistant carbon steel blade | 2 | pc | 3 |
| 5 | Tenderizer | with flat and textured side, non slip, 10 inches 25.5 cm, solid aluminum construction | 8 | pc | 3 |
| 6 | Skimmer | fine, extra fine mesh, 6 inches diameter, with stainless handle | 8 | pc | 3 |
| 7 | Wire Skimmer | small, nickel plated wire oil skimmer, 16 inches long overall, 5 inches diameter bowl | 8 | pc | 3 |
| 8 | Skimmer | spider, 5 inches diameter, natural bamboo handle, constructed of durable stainless steel with versatile woven design | 8 | pc | 3 |
| 9 | Strainer, small | fine, 6" diameter, with stainless handle | 8 | pc | 3 |
| 10 | Siever | small 12" diameter, stainless | 8 | pc | 3 |
| 11 | Strainer, medium | medium, fine stainless steel mesh, 9 inches diameter with stainless handle | 8 | pc | 3 |
| 12 | Turner | solid, stainless steel, with handy loop for hanging, 12 inches long | 8 | pc | 3 |
| 13 | Spatula | Stainless steel straight blade, 14 inches long with wood handle | 8 | pc | 3 |
| 14 | Wooden Spatula | large comfortable handle, 12 inches long, wooden | 8 | pc | 3 |
| 15 | Piping Bag | 12 inches, light weight, reusable, flexible polyester, coated, can be boiled, dishwasher safe | 8 | pc | 3 |
| 16 | Pastry Tubes | steel stainless, set of 24 pcs, different/assorted icing nozzles medium size, constructed of 18/8 quality stainless steel, comes in plastic storage box with lid | 8 | set | 3 |
| 17 | Strainer, chinois medium | medium, 8 inches diameter, stainless steel including handle | 3 | pc | 3 |
| 18 | Strainer, chinois small | small, 5 inches diameter, stainless steel including handle | 2 | pc | 3 |
| 19 | Funnel | general purpose, hard plastic, comes in 4 different sizes (small, medium, large, extra large) | 4 | set | 3 |
| 20 | Measuring Spoon | Stainless steel 6 pcs/set (1/8 tsp, 1/4 tsp, 1/2 tsp, 1 tsp, 1/2 tbsp, 1 tbsp) | 6 | set | 3 |
| 21 | Food Tong | 12 inches long, stainless steel, and wide shell head with locking | 8 | pc | 3 |
| 22 | Measuring Cup, liquid | glass graduated, 250 ml capacity | 8 | pc | 3 |
| 23 | Ice Cream Scooper | set of three, stainless steel (2 oz, 4 oz and 6 oz) | 2 | set | 3 |

Handwritten initials and numbers: 1, 2, 3, 4, 5, 6, 7, 8, 9, 10, 11, 12, 13, 14, 15, 16, 17, 18, 19, 20, 21, 22, 23, 24, 25, 26, 27, 28, 29, 30, 31, 32, 33, 34, 35, 36, 37, 38, 39, 40, 41, 42, 43, 44, 45, 46, 47, 48, 49, 50, 51, 52, 53, 54, 55, 56, 57, 58, 59, 60, 61, 62, 63, 64, 65, 66, 67, 68, 69, 70, 71, 72, 73, 74, 75, 76, 77, 78, 79, 80, 81, 82, 83, 84, 85, 86, 87, 88, 89, 90, 91, 92, 93, 94, 95, 96, 97, 98, 99, 100.

Procurement of CMU Boxes, Tools and Equipment and Mock-ups for the Mobile Training Laboratories (MTLs).

**TESDA Northern Samar Provincial Office
UEP Compound, Cataman, Northern Samar**

| NO. | ITEM | AGENCY SPECS | QTY | UNIT | No. Of Box |
|-----|------------------------|--|-----|------|------------|
| 24 | Cheese Cloth | 100% cotton 1 yard | 10 | pc | 3 |
| 25 | Serving Spoon | stainless steel , 9 inches long | 24 | pc | 3 |
| 26 | Pepper and Salt Mill | 2 in 1, wooden, 8" | 4 | pc | 3 |
| 27 | Weighing Scale | analog weighing scale ; maximum weight capacity , 5 kg, graduated by grams , removable and washable tray | 2 | unit | 3 |
| 28 | Weighing Scale | digital, 1000g, maximum weight capacity, battery operated (AAA battery) 0.1 g to 1000g , LCD display battery included. | 2 | unit | 3 |
| 29 | Apple Corer | corer head comfortable on slip handle, corer head is stainless steel | 4 | pc | 3 |
| 30 | Wire Whisk | 8"/20cm, aluminum, balloon style | 8 | pc | 3 |
| 31 | Wire Whisk, medium | medium, 10 inches/25 cm, aluminum, balloon style | 8 | pc | 3 |
| 32 | Wire Whisk, large | heavy duty, stainless steel, 14 inches, balloon style | 2 | pc | 3 |
| 33 | Measuring Cup, dry | stainless steel, 4 pcs/set (1c , 1/2c, 1/3c & 1/4c) | 1 | set | 3 |
| 34 | Chopping Board | 12 x17 inches, polyethylene, easy grip handle, white color | 10 | pc | 3 |
| 35 | Kitchen Scissors | stainless steel blade, size 2 cm x 12 cm x 27 cm, durable and sturdy handle with comfortable grip | 8 | pc | 3 |
| 36 | Soup Ladle | 3 oz capacity, stainless steel, with handle, round bottom | 8 | pc | 3 |
| 37 | Soup Ladle | 6 oz capacity, stainless steel handle, round bottom | 8 | pc | 3 |
| 38 | Soup Ladle | 8 oz capacity, stainless steel handle, round bottom | 3 | pc | 3 |
| 39 | Soup Ladle | 12 oz capacity, stainless handle, round bottom, | 2 | pc | 3 |
| 40 | Mixing Bowl | 12 inches diameter, 8-9 quarts capacity , stainless | 10 | pc | 3 |
| 41 | Kitchen Spoon | solid, stainless steel handle, comfortable non slip handle, round handle 4.5 x2.5 inches | 8 | pc | 3 |
| 42 | Kitchen Spoon | slotted, stainless steel, comfortable non slip handle, round handle 10 x 2.5 inches w/ hole | 8 | pc | 3 |
| 43 | Kitchen Fork | 7.5 cm x 4.5 cm x 37 cm or 10.5 inches, stainless steel, with 2 prongs, round handle | 8 | pc | 3 |
| 44 | Carving Fork | 10.5 inches, stainless steel, with 2 prongs, round handle | 3 | pc | 3 |
| 45 | Pocket Pin Thermometer | analog, temperature range from 0oF to 220 of, dial type | 3 | pc | 3 |
| 46 | Peeler | Straight blade type, dual stainless steel blade, metal handle 5",2"handle,3"blade | 8 | pc | 3 |

Procurement of CMU Boxes, Tools and Equipment and Mock-ups for the Mobile Training Laboratories (MTLs).

**TESDA Northern Samar Provincial Office
UEP Compound, Cataman, Northern Samar**

| NO. | ITEM | AGENCY SPECS | QTY | UNIT | No. Of Box |
|-----|---------------------|--|-----|------|------------|
| 47 | Stockpot | stainless, 17 quarts capacity (22.7 lit), 12 inches diameter (30.5 cm), depth 31 cm, 4 mm thickness | 2 | pc | 3 |
| 48 | Frying pan | pan, large, non stick, 26 cm diameter | 2 | pc | 3 |
| 49 | Colander | medium, stainless steel, 8 quarts capacity, with base | 2 | pc | 3 |
| 50 | Fish Poacher | medium, 18 inches (L) and 6 inches(w), stainless steel, with handle | 1 | pc | 3 |
| 51 | Casserole | small, stainless steel, 20 cm diameter, with cover | 8 | pc | 3 |
| 52 | Casserole | medium, stainless steel, 24 cm diameter with cover | 4 | pc | 3 |
| 53 | Double Boiler | medium, made from stainless steel, 2 quarts capacity, with lid cover | 1 | pc | 3 |
| 54 | Paellara | 40 cm diameter, (50 cm with handle), constructed of carbon steel, riveted secure melt handle, safe for all heating surfaces including induction | 4 | pc | 3 |
| 55 | Baking Tray | small, main material is carbon, rectangular, size 14 x 10 inches | 8 | pc | 3 |
| 56 | Utility Tray | hard plastic tray, rectangular 14x18 inches | 12 | pc | 3 |
| 57 | Fire Extinguisher | cylinder type, multipurpose ABC dry chemical, powder aluminum valve coated, rechargeable, 5 lbs capacity, with pressure gauge that allows for immediate pressure status check, with wall hanger, meets requirements for underwriter laboratory (UJ) | 1 | unit | 3 |
| 58 | Blender | 1.5 liter capacity, rated voltage, 230V, 60Hz, power consumption: 300 watts, sharp stainless steel blade, safety lock switch, with plastic stirrer for easy mixing | 1 | unit | 3 |
| 59 | Pressure Cooker | aluminum, 2 mm, 6 quarts capacity, pressured handle, central pressure valve with self locking mechanism | 1 | pc | 3 |
| 60 | Gas Stove with tank | 2 burner, made from stainless top body, automatic ignition, with complete accessories | 4 | unit | 3 |
| 61 | Working Table | high quality stainless steel foldable tables dimension: 3ft x 3ft | 4 | pc | 3 |
| 62 | Kitchen Sink | Kitchen sink, portable single bowl sink stainless steel, with steel collapsible frame legs, with drain hose, Dimension 50cmx50cmx30cm | 1 | unit | 3 |
| 63 | Laptop | 15.6", Core i7, 1.40GHz, wide screen, 1TB hard drive, 8GB DDR3 memory, NVIDIA GTX 670MX graphic processor, 3GB video memory, Gigabit 10/100/1000Mbps IEEE802.11b/g/n Wireless LAN, web camera, HDMI, Bluetooth, USB2.0, USB3.0, with Windows 8 OS, up to 6 hours charge-in-use battery, DVDRW super Multi with 1 year warranty | 1 | unit | 3 |

Handwritten signature/initials

Procurement of CMU Boxes, Tools and Equipment and Mock-ups for the Mobile Training Laboratories (MTLs).

**TESDA Northern Samar Provincial Office
UEP Compound, Catarman, Northern Samar**

| NO. | ITEM | AGENCY SPECS | QTY | UNIT | No. Of Box |
|--|-----------------------|--|-----|---------|------------|
| 64 | MS Office 2013 | Home & Student 1 user | 1 | unit | 3 |
| 65 | Projector | LCD Projector Portable, RGB liquid crystal shutter projection system (3LCD), White Light Output 2,600 lumens, Colour Light Output 2,600 lumens, XGA Resolution, lightweight: less than 2 kgs. | 1 | unit | 3 |
| 66 | HDMI cable | 3 meters, v1.4A HDMI cable for Projector | 1 | pc | 3 |
| 67 | Whiteboard | wooden whiteboard (2' x 3') with frame, 1 meter collapsible high stand | 1 | pc | 3 |
| 68 | PA System | 550W Portable with Trolley, with 2 wireless mics, 220V, RCA port, with warranty | 1 | unit | 3 |
| 69 | Megaphone | with speak and music switch and volume control, 25w | 1 | unit | 3 |
| 70 | First Aid Kit | First Aid Kit with the contents: betadine, alcohol, adhesive strips, band-aid, disposable gloves, hypoallergenic medical tape (1.25 cm x 9.1m), conforming bandage (5cm), triangular bandage (110m x 110cm), wound dressing no. 15, swab antiseptic, tweezers metal 8 cm, scissors disposable, safety pins assorted (12 pcs), hot and cold compress pack, first aid quick reference guide. | 1 | package | 3 |
| Electrical Installation and Maintenance NC II Tools and Equipment (for training purposes) | | | | | |
| 1 | Spirit Level | high impact plastic; magnetic; 3 vials; Length:24" | 1 | pc | 2 |
| 2 | Hacksaw | adjustable hacksaw frame with bi-metal hacksaw blade, 24 TPI, aluminum alloy frame and handle | 5 | pc | 2 |
| 3 | Pipe Cutter | max. capacity 1/8-2 " for steel or ductile iron pipes with steel handle | 2 | pc | 2 |
| 4 | Pipe Reamer | 2 " capacity, ratchet type with steel handle, 1/8-2 " capacity, suitable for use with power drives | 2 | pc | 2 |
| 5 | Pipe Threader | drop head with 3 sets of head and dies, sizes (1/2", 3/4", 1") | 2 | unit | 2 |
| 6 | Pipe Bender | manual, 1/2-3/4 inch bending radius, ductile high strength iron | 2 | unit | 2 |
| 7 | Electricians Plier | overall length 6, knife length: 5/8", material: carbon steel handle finished: plastic dipped | 25 | pc | 2 |
| 8 | Long Nose Plier | dyna grip, 152mm/6" inches carbon steel | 25 | pc | 2 |
| 9 | Phillips Screw Driver | 1x75, PH 2 x 100, PH 2x125 plastic and rubberized handle chrome vanadium, shank 4" | 25 | set | 2 |
| 10 | Flat Screw Driver | 3x75, 5x100, 6x125 plastic and rubberized handle chrome vanadium shank 4" | 25 | set | 2 |
| 11 | Wrench, Combination | 6mm,8mm,10mm,11mm,12mm,13mm,14mm,15mm,16mm,17mm,19mm, 21mm,22mm, 24 mm, chrome vanadium steel | 5 | set | 2 |
| 12 | Wire Stripper | automatic, cap. 1.5mm to 3.5mm | 10 | pc | 2 |
| 13 | Electrician Knife | blade length 3", taper ground cutlery single steel blade, ergonomically designed slip resistant grip | 25 | pc | 2 |
| 14 | Tool Holster | leather, 3 pocket & 4 holes with belt | 25 | pc | 2 |

Handwritten signature/initials

Procurement of CMU Boxes, Tools and Equipment and Mock-ups for the Mobile Training Laboratories (MTLs).

**TESDA Northern Samar Provincial Office
UEP Compound, Catarman, Northern Samar**

| NO. | ITEM | AGENCY SPECS | QTY | UNIT | No. Of Box |
|-----|----------------|---|-----|------|------------|
| 15 | Pull Push Rule | blade length 8 mtrs, blade width 1", high impact ABS case with durable rubber corrosion resistant Iru-zero end | 25 | pc | 2 |
| 16 | Claw Hammer | 16 oz., forged steel construction, hardened and tempered steel head, smooth face, wooden handle | 10 | pc | 2 |
| 17 | Heat Gun | 1600 watts, 230v, 60 Hz, 12.5 amp. dual temperature, with different nozzle | 2 | unit | 2 |
| 18 | Power Drill | drilling cap.:10mm, cap. wood: 20mm, wattage 350w, no load speed: 0-2500rpm, weight 1.1 kg., Rev.- for rotation, 3/8" capacity. 220VAC, 60Hz | 2 | unit | 2 |
| 19 | Multi-Tester | analog, standard-size analog multimeter for measuring voltage, current, and resistance. An auxiliary connector is also provided for checking transistors. Specifications: •DC Voltage Range: 0 to 1000V in seven ranges •AC Voltage Range: 0 to 1000V in five ranges •DC Current Range: 0 to 250mA in four ranges •Resistance Range: x1 to 20KW in four ranges •Transistor hFE Range: -0 to 1000 •Transistors Leakage Current (ICEO) Range: -0 to 150mAAF Output Range: -10dB to +22dB | 5 | unit | 2 |
| 20 | Clamp Ammeter | digital max. AC voltage measurement 600V, max. AC current measurement 400Aac, max. DC voltage measurement 600Vdc, max. resistance measurement 400ohms, battery type AAA, clamp meter type, continuity current, frequency, resistance, voltage, display type LCD, jaw capacity, bus bars 10x34mm, safety category voltage, 300V, 600V | 2 | unit | 2 |
| 21 | Pipe Vise | capacity 2", material steel, d with swivel base with dual locking nuts, 360 degrees of rotation. | 2 | pc | 2 |
| 22 | Laptop | 15.6", Core i7, 1.40GHz, wide screen, 1TB hard drive, 8GB DDR3 memory, NVIDIA GTX 670MX graphic processor, 3GB video memory, Gigabit 10/100/1000Mbps IEEE802.11b/g/n Wireless LAN, web camera, HDMI, Bluetooth, USB2.0, USB3.0, with Windows 8 OS, up to 6 hours charge-in-use battery, DVDRW super Multi with 1 year warranty | 1 | unit | 2 |
| 23 | MS Office 2013 | Home & Student 1 user | 1 | unit | 2 |
| 24 | Projector | LCD Projector Portable, RGB liquid crystal shutter projection system (3LCD), White Light Output 2,600 lumens, Colour Light Output 2,600 lumens, XGA Resolution, lightweight: less than 2 kgs. | 1 | unit | 2 |
| 25 | HDMI cable | 3 meters, v1.4A HDMI cable for Projector | 1 | pc | 2 |
| 26 | Whiteboard | wooden whiteboard (2' x 3') with frame, 1 meter collapsible high stand | 1 | pc | 2 |
| 27 | PA System | 550W Portable with Trolley, with 2 wireless mics, 220V, RCA port, with warranty | 1 | unit | 2 |
| 28 | Megaphone | with speak and music switch and volume control, 25w | 1 | unit | 2 |

Handwritten signature and initials

Procurement of CMU Boxes, Tools and Equipment and Mock-ups for the Mobile Training Laboratories (MTLs).

**TESDA Northern Samar Provincial Office
UEP Compound, Catarman, Northern Samar**

| NO. | ITEM | AGENCY SPECS | QTY | UNIT | No. Of Box |
|--|-----------------------------|--|-----|---------|------------|
| 29 | First Aid Kit | First Aid Kit with the contents: betadine, alcohol, adhesive strips, band-aid, disposable gloves, hypoallergenic medical tape (1.25 cm x 9.1m), conforming bandage (5cm), triangular bandage (110m x 110cm), wound dressing no. 15, swab antiseptic, tweezers metal 8 cm, scissors disposable, safety pins assorted (12 pcs), hot and cold compress pack, first aid quick reference guide. | 1 | package | 2 |
| Food Processing NC II Tools and Equipment (for training purposes) | | | | | |
| 1 | Weighing Scale | Manual weighing scale; maximum weight capacity, 5 kg., graduated by grams, removable and washable tray | 5 | unit | 3 |
| 2 | Weighing Scale | digital, 1000g, maximum weight capacity, battery operated (AAA battery) 0.1 g to 1000g , LCD display battery included. | 5 | unit | 3 |
| 3 | Paring Knives | stainless steel blade, 4 inches | 25 | pc | 3 |
| 4 | Peeler | Straight blade type, dual stainless steel blade, metal handle 5", 2" handle, 3" blade | 12 | pc | 3 |
| 5 | Measuring Spoon | Stainless steel 6 pcs/set (1/8 tsp, 1/4 tsp, 1/2 tsp, 1 tsp, 1/2 tbsp, 1 tbsp) | 6 | set | 3 |
| 6 | Measuring Cup, dry | stainless steel, 4 pcs/set (1c, 1/2c, 1/3c & 1/4c) | 6 | set | 3 |
| 7 | Measuring Cup, liquid | glass graduated, 250 ml capacity | 6 | pc | 3 |
| 8 | Clocks/Timer | digital, battery operated, with convenient clip, battery included. | 5 | pc | 3 |
| 9 | Mixing Bowl | 12 inches diameter, 8-9 quarts capacity , stainless | 12 | set | 3 |
| 10 | Chopping Board | 12x17 inches, polyethylene, easy grip handle, white color | 3 | set | 3 |
| 11 | Dial Thermometer | stainless steel, 12" stem, stainless clip | 5 | pc | 3 |
| 12 | Osterizers | 8 speed with pulse, 500 watts, 220 volts 60 hertz, stainless steel ice crusher blade, 6 cups glass jar capacity, with warranty. | 4 | unit | 3 |
| 13 | Jar Lifter | non slip handle, rubberized 5" full expansion | 5 | pc | 3 |
| 14 | Food Processors | with exact slice system, 2 in one wide mouth feed tube, with high, low, pulse, off operation, adjustable stainless steel slicing disc and ultra tight seal, 220 volts , 60 hertz, 700 watts | 1 | unit | 3 |
| 15 | Wire Baskets | stainless steel, rectangular, with handle, 4" x 17.75" x 14" (HxWxD) | 5 | pc | 3 |
| 16 | Casseroles | stainless steel, with cover, 5 quarts capacity, with long handles | 5 | pc | 3 |
| 17 | Saucepan | stainless steel, with cover and handle, 26 cm | 5 | pc | 3 |
| 18 | Spoon, wooden | wooden turner; size 12 inches | 15 | pc | 3 |
| 19 | Spoon, basting | 12" long, 100% solid wood, strong and durable. | 15 | pc | 3 |
| 20 | Paddle, wooden | solid wood, 24 inches length x 3-1/2 inches width | 4 | pc | 3 |
| 21 | Food Tong | 12 inches long, stainless steel, and wide shell head with locking | 14 | pc | 3 |
| 22 | Kitchen Scissors | stainless steel blade, size 2 cm x 12 cm x 27 cm, durable and sturdy handle with comfortable grip | 12 | pc | 3 |
| 23 | Steamer | 6 quarts base pan doubles as a stock pot, aluminum, with cover, 3 layer, 30 cm | 4 | pc | 3 |
| 24 | Fermented Containers (pail) | hard plastic, with 16 liter capacity, with cover | 5 | pc | 3 |
| 25 | Utility Tray | hard plastic tray, rectangular 14x18 inches | 20 | pc | 3 |

1
N
pd
df

Procurement of CMU Boxes, Tools and Equipment and Mock-ups for the Mobile Training Laboratories (MTLs).

**TESDA Northern Samar Provincial Office
UEP Compound, Catarman, Northern Samar**

| NO. | ITEM | AGENCY SPECS | QTY | UNIT | No. Of Box |
|--|------------------------|--|-----|---------|------------|
| 26 | Colander | medium, stainless steel, 8 quarts capacity, with base | 10 | pc | 3 |
| 27 | Smoke House | Width - 25" Height - 40" Length - 15", 3 Layers of Parilya inside, 1" for Tray above the Charcoal, 2" for the box of Charcoal, Gauge of Stainless - 1.0 Mirror | 1 | unit | 3 |
| 28 | Gas Stove with tank | 2 burner, made from stainless top body, automatic ignition, with complete accessories | 3 | unit | 3 |
| 29 | Polytemperature Sealer | 300mm long, 220 volts, 60 Hz, 400W | 2 | unit | 3 |
| 30 | Pressure Canner | 25 quarts, stainless steel | 2 | pc | 3 |
| 31 | Pressure Cooker | 8 quarts, stainless steel | 3 | pc | 3 |
| 32 | Electric Oven | 220 V, 60 Hz., 1000W, 18 L capacity, with warranty | 1 | unit | 3 |
| 33 | Meat Grinder | (size in cm) 49 x 23 x 29.5, stainless main materials, 220 volts, 60 Hz., 1/2 HP, with warranty | 1 | unit | 3 |
| 34 | Casseroles | stainless steel, 10" diameter, with lid | 4 | pc | 3 |
| 35 | Working Table | high quality stainless steel foldable tables dimension: 3ft x 3ft | 4 | pc | 3 |
| 36 | Chef Knife | 8 Inch, stainless steel full tang blade with plastic handle | 10 | pc | 3 |
| 37 | Laptop | 15.6", Core i7, 1.40GHz, wide screen, 1TB hard drive, 8GB DDR3 memory, NVIDIA GTX 670MX graphic processor, 3GB video memory, Gigabit 10/100/1000Mbps IEEE802.11b/g/n Wireless LAN, web camera, HDMI, Bluetooth, USB2.0, USB3.0, with Windows 8 OS, up to 6 hours charge-in-use battery, DVDRW super Multi with 1 year warranty | 1 | unit | 3 |
| 38 | MS Office 2013 | Home & Student 1 user | 1 | unit | 3 |
| 39 | Projector | LCD Projector Portable, RGB liquid crystal shutter projection system (3LCD), White Light Output 2,600 lumens, Colour Light Output 2,600 lumens, XGA Resolution, lightweight: less than 2 kgs. | 1 | unit | 3 |
| 40 | HDMI cable | 3 meters, v1.4A HDMI cable for Projector | 1 | pc | 3 |
| 41 | Whiteboard | wooden whiteboard (2' x 3') with frame, 1 meter collapsible high stand | 1 | pc | 3 |
| 42 | PA System | 550W Portable with Trolley, with 2 wireless mics, 220V, RCA port, with warranty | 1 | unit | 3 |
| 43 | Megaphone | with speak and music switch and volume control, 25w | 1 | unit | 3 |
| 44 | First Aid Kit | First Aid Kit with the contents: betadine, alcohol, adhesive strips, band-aid, disposable gloves, hypoallergenic medical tape (1.25 cm x 9.1m), conforming bandage (5cm), triangular bandage (110m x 110cm), wound dressing no. 15, swab antiseptic, tweezers metal 8 cm, scissors disposable, safety pins assorted (12 pcs), hot and cold compress pack, first aid quick reference guide. | 1 | package | 3 |
| Small Engine Repair (Motorcycle/Small Engine Servicing NC II) Tools and Equipment (for training purposes) | | | | | |
| 1 | Impact Drive Tool | 4pcs, 1/2" Impact Driver Set, heavy duty. | 10 | set | 4 |

7
N
H

Procurement of CMU Boxes, Tools and Equipment and Mock-ups for the Mobile Training Laboratories (MTLs).

**TESDA Northern Samar Provincial Office
UEP Compound, Catarman, Northern Samar**

| NO. | ITEM | AGENCY SPECS | QTY | UNIT | No. Of Box |
|-----|----------------------------|---|-----|------|------------|
| 2 | Multi-Tester | analog, standard-size analog multimeter for measuring voltage, current, and resistance. An auxiliary connector is also provided for checking transistors. Specifications: •DC Voltage Range: 0 to 1000V in seven ranges •AC Voltage Range: 0 to 1000V in five ranges •DC Current Range: 0 to 250mA in four ranges •Resistance Range: x1 to 20KW in four ranges •Transistor hFE Range: -0 to 1000 •Transistors Leakage Current (ICEO) Range: -0 to 150mAAF Output Range: -10dB to +22dB | 10 | pc | 4 |
| 3 | Oiler | metal case, 1/2 liter cap | 10 | pc | 4 |
| 4 | Steel Brush | wooden handle | 10 | pc | 4 |
| 5 | Hacksaw | adjustable hacksaw frame with bi-metal hacksaw blade, 24 TPI, aluminum alloy frame and handle | 10 | pc | 4 |
| 6 | Center Punch | high speed steel, 5x125 mm | 10 | pc | 4 |
| 7 | Cold Chisel | flat blade, 1" (W), 6" (L), hardened steel | 10 | pc | 4 |
| 8 | Fly Wheel/Magneto Puller | universal type, six in one fly wheel/ magneto puller | 10 | pc | 4 |
| 9 | Oil Seal Remover/Installer | pointed tip, hardened steel w/ straight handle, 3 pcs per set | 10 | set | 4 |
| 10 | Piston Ring Compressor | self locking w/ L wrench steel, range 2 1/8" to 5 inch diameter | 10 | pc | 4 |
| 11 | Valve Spring Compressor | spring loaded offset jaw overhead valve spring compressor, steel | 10 | pc | 4 |
| 12 | Clutch Assembly Remover | universal compressor clutch hub for removal and installation | 10 | pc | 4 |
| 13 | Electricians Plier | overall length 6, knife length: 5/8", material: carbon steel handle finished: plastic dipped | 10 | pc | 4 |
| 14 | Diagonal Cutting Plier | dyna grip, 152mm/6" inches carbon steel | 10 | pc | 4 |
| 15 | Mechanical Plier | 8", insulated handle | 10 | pc | 4 |
| 16 | Vise Gripped Plier | 10R straight jaw | 10 | pc | 4 |
| 17 | Feeler Gauge | 26 blade feeler gauge set, metric & English marked gauge | 10 | pc | 4 |
| 18 | Screwdriver, Flat | 8", magnetic tip, chrome vanadium, plastic handle | 10 | pc | 4 |

7
N
J

Procurement of CMU Boxes, Tools and Equipment and Mock-ups for the Mobile Training Laboratories (MTLs).

**TESDA Northern Samar Provincial Office
UEP Compound, Catarman, Northern Samar**

| NO. | ITEM | AGENCY SPECS | QTY | UNIT | No. Of Box |
|-----|----------------------|--|-----|------|------------|
| 19 | Screwdriver, Philips | 8", magnetic tip, chrome vanadium, plastic handle | 10 | pc | 4 |
| 20 | Ballpeen hammer | 12 oz., 11 1/2" overall length forged steel construction, hardened and tempered, wooden handle | 10 | pc | 4 |
| 21 | Hammer, Brass/copper | 1 lb., wooden handle | 10 | pc | 4 |
| 22 | Hammer, Plastic | 1 lb, wooden handle, plastic tip hammer | 10 | pc | 4 |
| 23 | Wrench, Sparkplug | 19x16 mm, hexagonal w/ handle | 10 | pc | 4 |
| 24 | Wrench, Combination | 6mm,8mm,10mm,11mm,12mm,13mm,14mm,15mm,16mm,17mm,19mm,21mm,22mm,24 mm, chrome vanadium steel | 10 | set | 4 |
| 25 | Wrench, Socket | 8 - 32 mm., black, 1/2" drive | 10 | set | 4 |
| 26 | Wrench, T-type | 8, 10, 12, 14 mm | 10 | set | 4 |
| 27 | Hand Tractor Engine | diesel engine, single piston, 4 stroke direct injection, 10-12 hp | 2 | unit | 4 |
| 28 | Laptop | 15.6", Core i7, 1.40GHz, wide screen, 1TB hard drive, 8GB DDR3 memory, NVIDIA GTX 670MX graphic processor, 3GB video memory, Gigabit 10/100/1000Mbps IEEE802.11b/g/n Wireless LAN, web camera, HDMI, Bluetooth, USB2.0, USB3.0, with Windows 8 OS, up to 6 hours charge-in-use battery, DVDRW super Multi with 1 year warranty | 1 | unit | 4 |
| 29 | MS Office 2013 | Home & Student 1 user | 1 | unit | 4 |
| 30 | Projector | LCD Projector Portable, RGB liquid crystal shutter projection system (3LCD), White Light Output 2,600 lumens, Colour Light Output 2,600 lumens, XGA Resolution, lightweight: less than 2 kgs. | 1 | unit | 4 |
| 31 | HDMI cable | 3 meters, v1.4A HDMI cable for Projector | 1 | pc | 4 |
| 32 | Whiteboard | wooden whiteboard (2' x 3') with frame, 1 meter collapsible high stand | 1 | pc | 4 |
| 33 | PA System | 550W Portable with Trolley, with 2 wireless mics, 220V, RCA port, with warranty | 1 | unit | 4 |
| 34 | Megaphone | with speak and music switch and volume control, 25w | 1 | unit | 4 |

1
N
af

Procurement of CMU Boxes, Tools and Equipment and Mock-ups for the Mobile Training Laboratories (MTLs).

**TESDA Northern Samar Provincial Office
UEP Compound, Catarman, Northern Samar**

| NO. | ITEM | AGENCY SPECS | QTY | UNIT | No. Of Box |
|-----|---------------|--|-----|---------|------------|
| 35 | First Aid Kit | First Aid Kit with the contents: betadine, alcohol, adhesive strips, band-aid, disposable gloves, hypoallergenic medical tape (1.25 cm x 9.1m), conforming bandage (5cm), triangular bandage (110m x 110cm), wound dressing no. 15, swab antiseptic, tweezers metal 8 cm, scissors disposable, safety pins assorted (12 pcs), hot and cold compress pack, first aid quick reference guide. | 1 | package | 4 |

1
2
3

**Procurement of CMU Boxes, Tools and Equipment and Mock-ups for
the Mobile Training Laboratories (MTLs).**

**TESDA Northern Samar Provincial Office
UEP Compound, Catarman, Northern Samar**

| Lot No. | Item / Description | Qty. | Unit | No. of Mock-up |
|--|---|------|-------|----------------|
| Electrical Installation and Maintenance (EIM) NC II Mock-up | | | | |
| 1 | Electrical Installation Maintenance (EIM) NC II Mock-Up | 1 | lot | 1 |
| SUPPLIES AND MATERIALS | | | | |
| 2 | Heat gun, 1200 watts | 1 | pc | 1 |
| 3 | PVC adapter with lock nuts | 20 | pc | 1 |
| 4 | Circuit breaker, 30A | 2 | pc | 1 |
| 5 | 1/2" diameter PVC pipe | 2 | meter | 1 |
| 6 | Cable ties, 100 pcs./pack | 1 | pack | 1 |
| 7 | Incandescent bulb, 220V, 25W | 5 | pc | 1 |
| 8 | One pole switch with plate, flush type | 5 | pc | 1 |
| 9 | Three way switch with plate, flush type | 5 | pc | 1 |
| 10 | Four way switch with plate, flush type | 5 | pc | 1 |
| 11 | Lamp receptacle 4" X 4" surface type | 5 | pc | 1 |
| 12 | Photo electrical (photocell) | 1 | pc | 1 |
| 13 | Convenience outlet, universal type | 5 | pc | 1 |
| 14 | Floor outlet, round type | 1 | pc | 1 |
| 15 | Ground fault current interrupter | 1 | pc | 1 |
| 16 | Circuit breaker 60A with built in housing | 1 | pc | 1 |
| 17 | Terminal block 15A 12 slots | 40 | pc | 1 |
| 18 | Automotive Wire #14 AWG (1 solid and 1 stranded) | 2 | roll | 1 |
| 19 | Terminal lug, Y type | 150 | pc | 1 |
| This include supplies and materials required in the fabrication of mock-up | | | | |
| Small Engine Repair (Motorcycle/Small Engine Servicing NC II) Tools and Equipment Mock-up | | | | |
| 1 | Motorcycle/Small Engine Collapsible Mock-Up | 1 | lot | 1 |
| SUPPLIES AND MATERIALS: | | | | |
| 2 | Auto wire, stranded # 16 | 1 | roll | 1 |
| 3 | Electrical tape, large black | 2 | pc | 1 |
| 4 | Head light assembly, 12 volts rectangular | 1 | pc | 1 |
| 5 | signal light assembly, 12 volts | 2 | pair | 1 |
| 6 | Horn, 12 volts | 1 | pc | 1 |
| 7 | Stop light switch, push button | 1 | pc | 1 |
| 8 | Signal light switch, double throw, toggle switch | 1 | pc | 1 |
| 9 | Ignition switch, gas engine type | 1 | pc | 1 |
| 10 | Signal light relay, 12 volts | 1 | pc | 1 |
| 11 | Push button switch for horn | 1 | pc | 1 |
| 12 | Motorcycle storage battery, 12 volts maintenance free | 1 | pc | 1 |
| 13 | Harness cover, 3/8" diameter (140/4) | 4 | meter | 1 |
| 14 | Harness connector, 6 terminals | 4 | pc | 1 |
| 15 | Male terminal, flat | 30 | pc | 1 |
| 16 | Female terminal, flat | 30 | pc | 1 |
| 17 | Headlight switch or toggle switch, single throw | 1 | pc | 1 |
| 18 | Crocodile clip, medium, red and black | 1 | pair | 1 |
| 19 | 3/16" diameter X 3/4" stove bolt, stainless | 20 | pc | 1 |
| 20 | 3/16" diameter hole, eye terminal | 10 | pc | 1 |

7
W go
af

| Procurement of CMU Boxes, Tools and Equipment and Mock-ups for the Mobile Training Laboratories (MTLs). | | | | |
|--|--|-------------|-------------|-----------------------|
| TESDA Northern Samar Provincial Office UEP Compound, Catarman, Northern Samar | | | | |
| Lot No. | Item / Description | Qty. | Unit | No. of Mock-up |
| 21 | Four stroke motorcycle engine, 125 or 155cc, surplus | 1 | unit | 1 |
| This include supplies and materials required in the fabrication of mock-up | | | | |

Handwritten signature or initials in the bottom right corner.

Procurement of CMU Boxes, Tools and Equipment and Mock-ups for the Mobile Training Laboratories (MTLs).

**TESDA Zamboanga del Norte Provincial Office
Olingan, Dipolog City Zamboanga del Norte**

| NO. | ITEM | AGENCY SPECS | QTY | UNIT | No. Of Box |
|---|--|---|-----|------|------------|
| Appliance Repair NC II Tools and Equipment (for training purposes) | | | | | |
| 1 | Soldering Iron | dual wattage, 25 watts/ 120watts, 220 volt 60 Hz, with long life tip, "gun type" | 25 | unit | 3 |
| 2 | Desoldering Tools | desoldering pump with precision regulated return, replacement tip compact, metal housing | 25 | unit | 3 |
| 3 | Screw driver assorted (Phillips and slotted) | 12x7x1 inches, 6 pieces per set, plastic handle | 5 | set | 3 |
| 4 | Long Nose Plier | dyna grip, 152mm/6" inches carbon steel | 5 | pc | 3 |
| 5 | Diagonal Cutting Plier | dyna grip, 152mm/6" inches carbon steel | 5 | pc | 3 |
| 6 | Nut Drivers | rust-resistant, nickel-plated bar, hexagonal shank, includes: 5mm, 6mm, 7mm, 8mm, 9mm, 10mm, 11mm | 5 | set | 3 |
| 7 | Wrench, Combination | 6mm,8mm,10mm,11mm,12mm,13mm,14mm,15mm, 16mm,17mm,19mm, 21mm,22mm, 24 mm, chrome vanadium steel | 5 | set | 3 |
| 8 | Wire Stripper | automatic, cap. 1.5mm to 3.5mm | 10 | pc | 3 |
| 9 | Ballpeen hammer | 12 oz., 11 1/2" overall length forged steel construction, hardened and tempered, wooden handle | 5 | pc | 3 |
| 10 | Flashlight | LED, 3 volts/6 volts, rechargeable | 5 | pc | 3 |
| 11 | Detector Light | test light, 220 volts | 5 | pc | 3 |
| 12 | Paint Brush | 4 inches width, wooden handle | 25 | pc | 3 |
| 13 | Microwave Oven | power capacity: 220V 1300 watts, interior capacity 20 liters, 8 programmes, defrost option, 26cm diameter rotating turntable, digital | 1 | unit | 3 |
| 14 | Washing Machine with dryer | power capacity: 500w, 220V, rust proof body, gear drive system, dolphin drive pulsator, washing capacity (dry weight) 7.5kg, spinning capacity (dry weight) 5.5kg, width should be more than 50 cm and length of not more than 100 cm | 1 | unit | 3 |
| 15 | Electric Fan | power capacity: 220V, 100w, 60Hz, 3 speed rotary switch, 18 inch metal blade, round/stable plastic base, thermal fuse protection, adjustable height stand fan | 1 | unit | 3 |
| 16 | Electric Rice Cooker | power capacity: 700w, 220V, 60Hz, automatic cooking feature, auto shutoff, glass lid, non-stick coated aluminum pan, Includes measuring cup and rice scoop | 1 | unit | 3 |

Handwritten initials/signature

Procurement of CMU Boxes, Tools and Equipment and Mock-ups for the Mobile Training Laboratories (MTLs).

**TESDA Zamboanga del Norte Provincial Office
Olingan, Dipolog City Zamboanga del Norte**

| NO. | ITEM | AGENCY SPECS | QTY | UNIT | No. Of Box |
|-----|--------------------|---|-----|------|------------|
| 17 | Electric Flat Iron | power capacity: 1000w, 220V, 60 Hz, non-stick Teflon soleplate, thermal fuse protected, variable temperature control, automatic thermostat Control, pilot lamp indicator | 1 | unit | 3 |
| 18 | Coffee Maker | power capacity: 550w, 220V, 60Hz, glass pitcher, anti-drip feature, 6 cup water capacity, water level indicator, swing-out filter basket | 1 | unit | 3 |
| 19 | Oven Toaster | power capacity: 1000w, 220V, 60Hz, stainless steel, 8 liter capacity, 15 minute timer, slide out chrome crumb rack, includes baking tray | 1 | unit | 3 |
| 20 | Blender | 1.5 liter capacity, rated voltage, 230V, 60Hz, power consumption: 300 watts, sharp stainless steel blade, safety lock switch, with plastic stirrer for easy mixing | 1 | unit | 3 |
| 21 | Multi Tester | analog, standard size analog multimeter for measuring voltage, current and resistance. An auxiliary connector is also provided for checking transistors. SPECIFICATION: •DC Voltage Range: 0 to 1000V in seven ranges •AC Voltage Range: 0 to 1000V in five ranges •DC Current Range: 0 to 250mA in four ranges •Resistance Range: x1 to 200MEG in four ranges •Transistor hFE Range: -0 to 1000 •Transistors Leakage Current (ICEO) Range: -0 to 150mAAF Output Range: -10dB to +22dB | 25 | unit | 3 |
| 22 | Multi Tester | Digital Multi meters are standard digital multimeter for measuring voltage, current, and resistance with 3-1/2 digit LCD display. This meter measures only 138mm x 70mm x 32mm and weighs approximately 140 grams, including battery. SPECIFICATION: •DC Voltage Range: 200mV to 600V in five ranges (auto ranging) •AC Voltage Range: 2V to 600V in four ranges (auto ranging) •DC Current Range: 200mA to 10A in six ranges •Resistance Range: 200 Ohms to 20M in six ranges Transistor hFE Test Range: 0 to 2000 | 25 | unit | 3 |
| 23 | Laptop | 15.6", Core i7, 1.40GHz, wide screen, 1TB hard drive, 8GB DDR3 memory, NVIDIA GTX 670MX graphic processor, 3GB video memory, Gigabit 10/100/1000Mbps IEEE802.11b/g/n Wireless LAN, web camera, HDMI, Bluetooth, USB2.0, USB3.0, with Windows 8 OS, up to 8 hours charge-in-use battery, DVDRW super Multi with 1 year warranty | 1 | unit | 3 |

7
M
H

Procurement of CMU Boxes, Tools and Equipment and Mock-ups for the Mobile Training Laboratories (MTLs).

**TESDA Zamboanga del Norte Provincial Office
Olingan, Dipolog City Zamboanga del Norte**

| NO. | ITEM | AGENCY SPECS | QTY | UNIT | No. Of Box |
|---|-----------------------|--|-----|---------|------------|
| 24 | MS Office 2013 | Home & Student f user | 1 | unit | 3 |
| 25 | Projector | LCD Projector Portable, RGB liquid crystal shutter projection system (3LCD), White Light Output 2,600 lumens, Colour Light Output 2,600 lumens, XGA Resolution, lightweight: less than 2 kgs. | 1 | unit | 3 |
| 26 | HDMI cable | 3 meters, v1.4A HDMI cable for Projector | 1 | pc | 3 |
| 27 | Whiteboard | wooden whiteboard (2' x 3') with frame, 1 meter collapsible high stand | 1 | pc | 3 |
| 28 | PA System | 550W Portable with Trolley, with 2 wireless mics, 220V, RCA port, with warranty | 1 | unit | 3 |
| 29 | Megaphone | with speak and music switch and volume control, 25w | 1 | unit | 3 |
| 30 | First Aid Kit | First Aid Kit with the contents: betadine, alcohol, adhesive strips, band-aid, disposable gloves, hypoallergenic medical tape (1.25 cm x 9.1m), conforming bandage (5cm), triangular bandage (110m x 110cm), wound dressing no. 15, swab antiseptic, tweezers metal 8 cm, scissors disposable, safety pins assorted (12 pcs), hot and cold compress pack, first aid quick reference guide. | 1 | package | 3 |
| Bread and Pastry NC II Tools and Equipment (for training purposes) | | | | | |
| 1 | Measuring Cup, dry | stainless steel, 4 pcs/set (1c , 1/2c, 1/3c & 1/4c) | 12 | pc | 3 |
| 2 | Measuring Cup, liquid | glass graduated, 250 ml capacity | 12 | pc | 3 |
| 3 | Measuring Spoon | Stainless steel 6 pcs/set(1/8 tsp, 1/4 tsp, 1/2tsp, 1 tsp 1/2 tbsp, 1 tbsp) | 12 | set | 3 |
| 4 | Cake Turn Table | plastic cake turntable with locking switch, rubberized feet, white, 12.6x12.6x3.54 inches (LxWxD) | 10 | pc | 3 |
| 5 | Decorating Tips | stainless steel, 24-piece cake decorating tip set, package size: 17cm x 12cm x 5cm (6.69 x 4.72 x 1.97inches) | 25 | set | 3 |
| 6 | Rolling Pin | wooden, size 33.5 x 5cm, light weight comfortable grip | 25 | pc | 3 |
| 7 | Pie Plate, size 6" | aluminum pie pan, 6" diameter x 5/8 in deep, heavy weight round pan | 10 | pc | 3 |
| 8 | Pie Plate, size 8" | pie pan, 8" aluminum deep dish pie pan, standard weight aluminum, 8" top outside diameter | 10 | pc | 3 |
| 9 | Pie Plate, size 10" | deep aluminum pie pan, 10" diameter, depth 1-1/4", made of 0.7mm thick satin finished aluminum | 10 | pc | 3 |
| 10 | Jelly Roll Pan | aluminum, dimension: 2" x 13 x 8" (HxWxD) | 10 | pc | 3 |

TN
AS

Procurement of CMU Boxes, Tools and Equipment and Mock-ups for the Mobile Training Laboratories (MTLs).

**TESDA Zamboanga del Norte Provincial Office
Olingan, Dipolog City Zamboanga del Norte**

| NO. | ITEM | AGENCY SPECS | QTY | UNIT | No. Of Box |
|-----|----------------------|--|-----|------|------------|
| 11 | Cake Spring Form Pan | heavy aluminum spring form pan, heavy duty frame, spring form sides for easy removal, size 9 x 3" | 10 | pc | 3 |
| 12 | Pie Cutter | triple riveled pizza cutter, made of stainless steel, rolling wheel slicer, 6" | 10 | pc | 3 |
| 13 | Rubber Scraper | rubber head, high heat resistant, flexible, 12", color white | 25 | pc | 3 |
| 14 | Spatula | Stainless steel straight blade, 14 inches long with wood handle | 25 | pc | 3 |
| 15 | Cake Stand with tier | 3 tier cake round acrylic cake stand, 3 plates clear, size: 15cm, 20cm, 25cm, 10 inches gap between each tier | 6 | set | 3 |
| 16 | Saucepan | Stainless steel with cover and handle 26cm | 15 | pc | 3 |
| 17 | Ladle | stainless steel, 12 inches, comes with brush finished handle, hole in the handle for easy hanging | 10 | pc | 3 |
| 18 | Chef Knife | 8 inch, stainless steel full tang blade with plastic handle | 12 | pc | 3 |
| 19 | Chopping Board | 12 x17 inches, polyethylene, easy grip handle, white color | 10 | pc | 3 |
| 20 | Weighing Scale | manual, maximum weight capacity 2kg, graduated by grams, removable and washable tray | 6 | pc | 3 |
| 21 | Grater | made of nonreactive stainless steel easy grip handle | 10 | pc | 3 |
| 22 | Wooden Spoon | wooden turner, size 12 inches | 25 | pc | 3 |
| 23 | Piping Bag | 12 inches , light weight, reusable, flexible polyester, coated can be boiled, dishwasher safe | 25 | pc | 3 |
| 24 | Mixing Bowl | 12 inches diameter ,8-9 quarts capacity, stainless | 15 | pc | 3 |
| 25 | Wire Whisk | 8"/20cm, aluminum, balloon style | 25 | pc | 3 |
| 26 | Electric Mixer | 4 qt. stainless steel bowl, 5 speeds & quick burst button, bowl rest TM mixer stabilizer, doubles as a hand mixer, 220V, 290-watts peak power, versatile attachment set includes traditional beaters, whisk and dough hooks, brushed stainless steel | 5 | unit | 3 |
| 27 | Dough Cutter | dough scraper 6" wide x 4", high polished stainless steel blade | 10 | pc | 3 |
| 28 | Oven (gas) | stainless door, 2 trays oven with tempered glass window, 22-25" collapsible stand | 1 | unit | 3 |
| 29 | Pastry Brush | pastry/basting brush, natural wood handle brushes, 1.5" size | 10 | pc | 3 |
| 30 | Bread Knife | 8", serrated edge stain free high -carbon steel blade texture red polypropylene handle | 10 | pc | 3 |

*P N
af*

Procurement of CMU Boxes, Tools and Equipment and Mock-ups for the Mobile Training Laboratories (MTLs).

**TESDA Zamboanga del Norte Provincial Office
Olingan, Dipolog City Zamboanga del Norte**

| NO. | ITEM | AGENCY SPECS | QTY | UNIT | No. Of Box |
|--|---------------------|--|-----|---------|------------|
| 31 | Flour Sifter | stainless steel mesh flour sifter strainer, 12" | 10 | pc | 3 |
| 32 | Baking Sheet | aluminum, 13" x 18" | 15 | pc | 3 |
| 33 | Muffin Pans | 12 holes, 3 oz. capacity per holes, aluminum | 25 | pc | 3 |
| 34 | Working Table | high quality stainless steel foldable tables dimension: 3ft x 3ft | 4 | pc | 3 |
| 35 | Gas Stove with tank | 2 burner, made from stainless top body, automatic ignition, with complete accessories | 2 | pc | 3 |
| 36 | Kitchen Sink | Kitchen sink, portable single bowl sink stainless steel, with steel collapsible frame legs, with drain hose, Dimension 50cmx50cmx30cm | 1 | pc | 3 |
| 37 | Weighing Scale | digital, 1000g, maximum weight capacity, battery operated (AAA battery) 0.1 g to 1000g, LCD display battery included. | 5 | pc | 3 |
| 38 | Laptop | 15.6", Core i7, 1.40GHz, wide screen, 1TB hard drive, 8GB DDR3 memory, NVIDIA GTX 670MX graphic processor, 3GB video memory, Gigabit 10/100/1000Mbps IEEE802.11b/g/n Wireless LAN, web camera, HDMI, Bluetooth, USB2.0, USB3.0, with Windows 8 OS, up to 6 hours charge-in-use battery, DVDRW super Multi with 1 year warranty | 1 | unit | 3 |
| 39 | MS Office 2013 | Home & Student 1 user | 1 | unit | 3 |
| 40 | Projector | LCD Projector Portable, RGB liquid crystal shutter projection system (3LCD), White Light Output 2,600 lumens, Colour Light Output 2,600 lumens, XGA Resolution, lightweight: less than 2 kgs. | 1 | unit | 3 |
| 41 | HDMI cable | 3 meters, v1.4A HDMI cable for Projector | 1 | pc | 3 |
| 42 | Whiteboard | wooden whiteboard (2' x 3') with frame, 1 meter collapsible high stand | 1 | pc | 3 |
| 43 | PA System | 550W Portable with Trolley, with 2 wireless mics, 220V, RCA port, with warranty | 1 | unit | 3 |
| 44 | Megaphone | with speak and music switch and volume control, 25w | 1 | unit | 3 |
| 45 | First Aid Kit | First Aid Kit with the contents: betadine, alcohol, adhesive strips, band-aid, disposable gloves, hypoallergenic medical tape (1.25 cm x 9.1m), conforming bandage (5cm), triangular bandage (110m x 110cm), wound dressing no. 15, swab antiseptic, tweezers metal 8 cm, scissors disposable, safety pins assorted (12 pcs), hot and cold compress pack, first aid quick reference guide. | 1 | package | 3 |
| Electrical Installation and Maintenance NC II Tools and Equipment (for training purposes) | | | | | |
| 1 | Spirit Level | high impact plastic; magnetic; 3 vials; Length:24" | 1 | pc | 2 |
| 2 | Hacksaw | adjustable hacksaw frame with bi-metal hacksaw blade, 24 TPI, aluminum alloy frame and handle | 5 | pc | 2 |

Handwritten signature and initials

Procurement of CMU Boxes, Tools and Equipment and Mock-ups for the Mobile Training Laboratories (MTLs).

**TESDA Zamboanga del Norte Provincial Office
Olingan, Dipolog City Zamboanga del Norte**

| NO. | ITEM | AGENCY SPECS | QTY | UNIT | No. Of Box |
|-----|-----------------------|--|-----|------|------------|
| 3 | Pipe Cutter | max. capacity 1/8-2 " for steel or ductile iron pipes with steel handle | 2 | pc | 2 |
| 4 | Pipe Reamer | 2 " capacity, ratchet type with steel handle, 1/8-2 " capacity, suitable for use with power drives | 2 | pc | 2 |
| 5 | Pipe Threader | drop head with 3 sets of head and dies, sizes (1/2", 3/4", 1") | 2 | unit | 2 |
| 6 | Pipe Bender | manual, 1/2-3/4 inch bending radius, ductile high strength iron | 2 | unit | 2 |
| 7 | Electricians Plier | overall length 6, knife length: 5/8", material: carbon steel handle finished: plastic dipped | 25 | pc | 2 |
| 8 | Long Nose Plier | dyna grip, 152mm/6" inches carbon steel | 25 | pc | 2 |
| 9 | Phillips Screw Driver | 1x75, PH 2 x 100, PH 2x125 plastic and rubberized handle chrome vanadium, shank 4" | 25 | set | 2 |
| 10 | Flat Screw Driver | 3x75, 5x100, 6x125 plastic and rubberized handle chrome vanadium shank 4" | 25 | set | 2 |
| 11 | Wrench, Combination | 6mm,8mm,10mm,11mm,12mm,13mm,14mm,15mm, 16mm,17mm,19mm, 21mm,22mm, 24 mm, chrome vanadium steel | 5 | set | 2 |
| 12 | Wire Stripper | automatic, cap. 1.5mm to 3.5mm | 10 | pc | 2 |
| 13 | Electrician Knife | blade length 3", taper ground cutlery single steel blade, ergonomically designed slip resistant grip | 25 | pc | 2 |
| 14 | Tool Holster | leather, 3 pocket & 4 holes with belt | 25 | pc | 2 |
| 15 | Pull Push Rule | blade length 8 mtrs, blade width 1", high impact ABS case with durable rubber corrosion resistant lru-zero end | 25 | pc | 2 |
| 16 | Claw Hammer | 16 oz., forged steel construction, hardened and tempered steel head, smooth face, wooden handle | 10 | pc | 2 |
| 17 | Heat Gun | 1600 watts, 230v, 60 Hz, 12.5 amp. dual temperature, with different nozzle | 2 | unit | 2 |
| 18 | Power Drill | drilling cap.:10mm, cap. wood: 20mm, wattage 350w, no load speed: 0-2500rpm, weight 1.1 kg., Rev.- for rotation, 3/8" capacity. 220VAC, 60Hz | 2 | unit | 2 |
| 19 | Multi-Tester | analog, standard-size analog multimeter for measuring voltage, current, and resistance. An auxiliary connector is also provided for checking transistors. Specifications: •DC Voltage Range: 0 to 1000V in seven ranges •AC Voltage Range: 0 to 1000V in five ranges •DC Current Range: 0 to 250mA in four ranges •Resistance Range: x1 to 20KW in four ranges •Transistor hFE Range: -0 to 1000 •Transistors Leakage Current (ICEO) Range: -0 to 150mAAF Output Range: -10dB to +22dB | 5 | unit | 2 |
| 20 | Clamp Ammeter | digital max. AC voltage measurement 600V, max. AC current measurement 400Aac, max. DC voltage measurement 600Vdc, max. resistance measurement 400ohms, battery type AAA, clamp meter type, continuity current, frequency, resistance, voltage, display type LCD, jaw capacity, bus bars 10x34mm, safety category voltage, 300V, 600V | 2 | unit | 2 |
| 21 | Pipe Vise | capacity 2", material steel, d with swivel base with dual locking nuts, 360 degrees of rotation. | 2 | pc | 2 |

Handwritten marks:
N
of

Procurement of CMU Boxes, Tools and Equipment and Mock-ups for the Mobile Training Laboratories (MTLs).

**TESDA Zamboanga del Norte Provincial Office
Olingan, Dipolog City Zamboanga del Norte**

| NO. | ITEM | AGENCY SPECS | QTY | UNIT | No. Of Box |
|--|-----------------------|--|-----|---------|------------|
| 22 | Laptop | 15.6", Core i7, 1.40GHz, wide screen, 1TB hard drive, 8GB DDR3 memory, NVIDIA GTX 670MX graphic processor, 3GB video memory, Gigabit 10/100/1000Mbps IEEE802.11b/g/n Wireless LAN, web camera, HDMI, Bluetooth, USB2.0, USB3.0, with Windows 8 OS, up to 6 hours charge-in-use battery, DVDRW super Multi with 1 year warranty | 1 | unit | 2 |
| 23 | MS Office 2013 | Home & Student 1 user | 1 | unit | 2 |
| 24 | Projector | LCD Projector Portable, RGB liquid crystal shutter projection system (3LCD), White Light Output 2,600 lumens, Colour Light Output 2,600 lumens, XGA Resolution, lightweight: less than 2 kgs. | 1 | unit | 2 |
| 25 | HDMI cable | 3 meters, v1.4A HDMI cable for Projector | 1 | pc | 2 |
| 26 | Whiteboard | wooden whiteboard (2' x 3') with frame, 1 meter collapsible high stand | 1 | pc | 2 |
| 27 | PA System | 550W Portable with Trolley, with 2 wireless mics, 220V, RCA port, with warranty | 1 | unit | 2 |
| 28 | Megaphone | with speak and music switch and volume control, 25w | 1 | unit | 2 |
| 29 | First Aid Kit | First Aid Kit with the contents: betadine, alcohol, adhesive strips, band-aid, disposable gloves, hypoallergenic medical tape (1.25 cm x 9.1m), conforming bandage (5cm), triangular bandage (110m x 110cm), wound dressing no. 15, swab antiseptic, tweezers metal 8 cm, scissors disposable, safety pins assorted (12 pcs), hot and cold compress pack, first aid quick reference guide. | 1 | package | 2 |
| Food Processing NC II Tools and Equipment (for training purposes) | | | | | |
| 1 | Weighing Scale | Manual weighing scale; maximum weight capacity, 5 kg., graduated by grams, removable and washable tray | 5 | unit | 3 |
| 2 | Weighing Scale | digital, 1000g, maximum weight capacity, battery operated (AAA battery) 0.1 g to 1000g , LCD display battery included. | 5 | unit | 3 |
| 3 | Paring Knives | stainless steel blade, 4 inches | 25 | pc | 3 |
| 4 | Peeler | Straight blade type, dual stainless steel blade, metal handle 5", 2" handle, 3" blade | 12 | pc | 3 |
| 5 | Measuring Spoon | Stainless steel 6 pcs/set (1/8 tsp, 1/4 tsp, 1/2 tsp, 1 tsp 1/2 tbsp, 1 tbsp) | 6 | set | 3 |
| 6 | Measuring Cup, dry | stainless steel, 4 pcs/set (1c , 1/2c, 1/3c & 1/4c) | 6 | set | 3 |
| 7 | Measuring Cup, liquid | glass graduated, 250 ml capacity | 6 | pc | 3 |
| 8 | Clocks/Timer | digital, battery operated, with convenient clip, battery included. | 5 | pc | 3 |
| 9 | Mixing Bowl | 12 inches diameter, 8-9 quarts capacity , stainless | 12 | set | 3 |
| 10 | Chopping Board | 12x17 inches, polyethylene, easy grip handle, white color | 3 | set | 3 |
| 11 | Dial Thermometer | stainless steel, 12" stem, stainless clip | 5 | pc | 3 |
| 12 | Osterizers | 8 speed with pulse, 500 watts, 220 volts 60 hertz, stainless steel ice crusher blade, 6 cups glass jar capacity, with warranty. | 4 | unit | 3 |
| 13 | Jar Lifter | non slip handle, rubberized 5" full expansion | 5 | pc | 3 |

TN
dg

Procurement of CMU Boxes, Tools and Equipment and Mock-ups for the Mobile Training Laboratories (MTLs).

**TESDA Zamboanga del Norte Provincial Office
Olingan, Dipolog City Zamboanga del Norte**

| NO. | ITEM | AGENCY SPECS | QTY | UNIT | No. Of Box |
|-----|-----------------------------|--|-----|------|------------|
| 14 | Food Processors | with exact slice system, 2 in one wide mouth feed tube, with high, low, pulse, off operation, adjustable stainless steel slicing disc and ultra tight seal, 220 volts, 60 hertz, 700 watts | 1 | unit | 3 |
| 15 | Wire Baskets | stainless steel, rectangular, with handle, 4" x 17.75" x 14" (HxWxD) | 5 | pc | 3 |
| 16 | Casseroles | stainless steel, with cover, 5 quarts capacity, with long handles | 5 | pc | 3 |
| 17 | Saucepan | stainless steel, with cover and handle, 26 cm | 5 | pc | 3 |
| 18 | Spoon, wooden | wooden turner, size 12 inches | 15 | pc | 3 |
| 19 | Spoon, basting | 12" long, 100% solid wood, strong and durable. | 15 | pc | 3 |
| 20 | Paddle, wooden | solid wood, 24 inches length x 3-1/2 inches width | 4 | pc | 3 |
| 21 | Food Tong | 12 inches long, stainless steel, and wide shell head with locking | 14 | pc | 3 |
| 22 | Kitchen Scissors | stainless steel blade, size 2 cm x 12 cm x 27 cm, durable and sturdy handle with comfortable grip | 12 | pc | 3 |
| 23 | Steamer | 8 quarts base pan doubles as a stock pot aluminum, with cover, 3 layer, 30 cm | 4 | pc | 3 |
| 24 | Fermented Containers (pail) | hard plastic, with 16 liter capacity, with cover | 5 | pc | 3 |
| 25 | Utility Tray | hard plastic tray, rectangular 14x18 inches | 20 | pc | 3 |
| 26 | Colander | medium, stainless steel, 8 quarts capacity, with base | 10 | pc | 3 |
| 27 | Smoke House | Width - 25" Height - 40" Length - 15", 3 Layers of Parilya inside, 1" for Tray above the Charcoal, 2" for the box of Charcoal, Gauge of Stainless - 1.0 Mirror | 1 | unit | 3 |
| 28 | Gas Stove with tank | 2 burner, made from stainless top body, automatic ignition, with complete accessories | 3 | unit | 3 |
| 29 | Polytemperature Sealer | 300mm long, 220 volts, 60 Hz, 400W | 2 | unit | 3 |
| 30 | Pressure Canner | 25 quarts, stainless steel | 2 | pc | 3 |
| 31 | Pressure Cooker | 8 quarts, stainless steel | 3 | pc | 3 |
| 32 | Electric Oven | 220 V, 60 Hz., 1000W, 18 L capacity, with warranty | 1 | unit | 3 |
| 33 | Meat Grinder | (size in cm) 49 x 23 x 29.5, stainless main materials, 220 volts, 60 Hz., 1/2 HP, with warranty | 1 | unit | 3 |
| 34 | Casseroles | stainless steel, 10" diameter, with lid | 4 | pc | 3 |
| 35 | Working Table | high quality stainless steel foldable tables dimension: 3ft x 3ft | 4 | pc | 3 |
| 36 | Chef Knife | 8 inch, stainless steel full tang blade with plastic handle | 10 | pc | 3 |
| 37 | Laptop | 15.6", Core i7, 1.40GHz, wide screen, 1TB hard drive, 8GB DDR3 memory, NVIDIA GTX 670MX graphic processor, 3GB video memory, Gigabit 10/100/1000Mbps IEEE802.11b/g/n Wireless LAN, web camera, HDMI, Bluetooth, USB2.0, USB3.0, with Windows 8 OS, up to 6 hours charge-in-use battery, DVDRW super Multi with 1 year warranty | 1 | unit | 3 |
| 38 | MS Office 2013 | Home & Student 1 user | 1 | unit | 3 |
| 39 | Projector | LCD Projector Portable, RGB liquid crystal shutter projection system (3LCD), White Light Output 2,600 lumens, Colour Light Output 2,600 lumens, XGA Resolution, lightweight: less than 2 kgs. | 1 | unit | 3 |
| 40 | HDMI cable | 3 meters, v1.4A HDMI cable for Projector | 1 | pc | 3 |

7/2
dy 98

Procurement of CMU Boxes, Tools and Equipment and Mock-ups for the Mobile Training Laboratories (MTLs).

**TESDA Zamboanga del Norte Provincial Office
Olingan, Dipolog City Zamboanga del Norte**

| NO. | ITEM | AGENCY SPECS | QTY | UNIT | No. Of Box |
|--|-------------------------------|--|-----|---------|------------|
| 41 | Whiteboard | wooden whiteboard (2' x 3') with frame, 1 meter collapsible high stand | 1 | pc | 3 |
| 42 | PA System | 550W Portable with Trolley, with 2 wireless mics, 220V, RCA port, with warranty | 1 | unit | 3 |
| 43 | Megaphone | with speak and music switch and volume control, 25w | 1 | unit | 3 |
| 44 | First Aid Kit | First Aid Kit with the contents: betadine, alcohol, adhesive strips, band-aid, disposable gloves, hypoallergenic medical tape (1.25 cm x 9.1m), conforming bandage (5cm), triangular bandage (110m x 110cm), wound dressing no. 15, swab antiseptic, tweezers metal 8 cm, scissors disposable, safety pins assorted (12 pcs), hot and cold compress pack, first aid quick reference guide. | 1 | package | 3 |
| Plumbing NC II A112 Tools and Equipment (for training purposes) | | | | | |
| 1 | Pipe Wrench | 12" straight, heavy duty, forged alloy steel 12", pipe capacity 2" or 50mm, weight 1.2 kg. cast-iron housing and I-beam handle with full floating forged hook jaw, featuring self cleaning threads with replaceable hook and heel jaws | 5 | pc | 3 |
| 2 | Pipe Wrench | 14" straight, heavy duty, forged alloy steel 12", pipe capacity 2" or 50mm, weight 1.8 kg. cast-iron housing and I-beam handle with full floating forged hook jaw, featuring self cleaning threads with replaceable hook and heel jaws | 5 | pc | 3 |
| 3 | Pull Push Rule | blade length 8 mtrs, blade width 1", high impact ABS case with durable rubber corrosion resistant Iru-zero end | 10 | pc | 3 |
| 4 | Hacksaw | adjustable hacksaw frame with bi-metal hacksaw blade, 24 TPI, aluminum alloy frame and handle | 5 | pc | 3 |
| 5 | Spirit Level | high impact plastic; magnetic; 3 vials; Length:24" | 5 | pc | 3 |
| 6 | Pipe Reamer | 2 " capacity, ratchet type with steel handle, 1/8-2 " capacity, suitable for use with power drives | 5 | pc | 3 |
| 7 | Pipe Cutter | max. capacity 1/8-2 " for steel or ductile iron pipes with steel handle | 5 | pc | 3 |
| 8 | Adjustable Wrench | alloy steel, 0 - 2 " jaw opening, 10" length | 5 | pc | 3 |
| 9 | Mechanical Plier | mechanical, plastic dipped insulated handle, 6 " length, rust-resistant chrome finish, two position adjustable joint pliers | 5 | pc | 3 |
| 10 | Pipe Vise | capacity 2", material steel, d with swivel base with dual locking nuts, 360 degrees of rotation. | 2 | pc | 3 |
| 11 | Pipe Threader | drop head with 3 sets of head and dies, sizes (1/2", 3/4", 1") | 2 | pc | 3 |
| 12 | Portable Tri-stand Chain Vise | 1/8 to 6 in., rear pipe support, rugged tool tray capacity: 1/8" - 6", leg locking: over center tool tray | 3 | pc | 3 |
| 13 | Manual Pressure Test Pump | 6 mpa, 860 psi max. pressure, 12 L. capacity, with brass pump valve | 1 | pc | 3 |
| 14 | Socket Fusion Machine | 20 mm - 32 mm cap, 3/4", 1", 1-1/4" and 1-1/2", 220V, 1600w | 2 | pc | 3 |
| 15 | Ballpeen hammer | 12 oz., 11 1/2" overall length forged steel construction, hardened and tempered, wooden handle | 5 | pc | 3 |

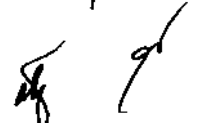
7/11

Procurement of CMU Boxes, Tools and Equipment and Mock-ups for the Mobile Training Laboratories (MTLs).

**TESDA Zamboanga del Norte Provincial Office
Olingan, Dipolog City Zamboanga del Norte**

| NO. | ITEM | AGENCY SPECS | QTY | UNIT | No. Of Box |
|-----|---------------------------|--|-----|------|------------|
| 16 | Angle Grinder | 4 "diameter, wheel cap, 220V, 60 Hz, single phase, 11,000 rpm, all-ball bearing design and metal gear | 2 | pc | 3 |
| 17 | Electric Portable Drill | 1/2" bit jaw capacity, 220V, single phase, variable speed (0-550 rpm), heavy duty, 1/2" drill chuck | 1 | pc | 3 |
| 18 | Carpenter Steel Square | high tempered aluminum steel, 2" x 16" x 24", 5-60 and 30-degree angle markings, high tempered aluminum for maximum durability, 1/8-inch graduations for long-term visibility, body: 24 by 2-inches, tongue: 16 by 1-1/2" | 4 | pc | 3 |
| 19 | Claw Hammer | 16 oz., forged steel construction, hardened and tempered steel head, smooth face, wooden handle | 5 | pc | 3 |
| 20 | Paint Brush | 1/2" round trim brush soft bristle, tin-plated ferrules | 10 | pc | 3 |
| 21 | Hand Gloves | 5 finger, poly/cotton blend with a latex coated palm | 25 | pc | 3 |
| 22 | Safety Hard Hat | V-rib, yellow ball-cap style hard hat with 6 point ratchet-type headgear, 2 point chin strap and V rib on top, polyethylene material | 25 | pc | 3 |
| 23 | Safety Shoes | heavy duty steel toe cap, waterproof, anti static (sizes 40-42) its anti-static and heat resistant (up to 300 degree C/572 degree F) with TPU SAFETY cell construction steel toe cap | 25 | pc | 3 |
| 24 | Safety Goggles | clear polycarbonate, woven elastic strap (adjustable) | 25 | pc | 3 |
| 25 | Water Meter | multi jet plastic meter, 1/2" NPT, 20 gpm, brass body | 1 | pc | 3 |
| 26 | Water Closet | flush type, ceramic, dimension (LxWxH): 684x430x787 mm, flushing action: siphonic, single/dual flush: single flush, flush Volume: 6L, flushing activation: front lever, rough-in: 305mm, discharge: floor cover | 1 | pc | 3 |
| 27 | Lavatory with Faucet | center hole, with mixing hot and cold faucet, ceramic, wall hung type, wall hung sink, 4-inch center faucet holes, front overflow, self-draining deck area with contoured back and side splash shields | 2 | pc | 3 |
| 28 | Kitchen Sink with Faucet | stainless steel, rust and heat resistant, grade 304, 74 cm x 51.5 cm, 16.2 mm outlet hole | 1 | pc | 3 |
| 29 | Single Point Water Heater | 4.5kw, 220V, 60 Hz, 2 psi min water pressure, 55 psi, 2 L/min minimum water flow, 1/2" BSP | 2 | pc | 3 |
| 30 | Laptop | 15.6", Core i7, 1.40GHz, wide screen, 1TB hard drive, 8GB DDR3 memory, NVIDIA GTX 670MX graphic processor, 3GB video memory, Gigabit 10/100/1000Mbps IEEE802.11b/g/n Wireless LAN, web camera, HDMI, Bluetooth, USB2.0, USB3.0, with Windows 8 OS, up to 6 hours charge-in-use battery, DVDRW super Multi with 1 year warranty | 1 | unit | 3 |
| 31 | MS Office 2013 | Home & Student 1 user | 1 | unit | 3 |
| 32 | Projector | LCD Projector Portable, RGB liquid crystal shutter projection system (3LCD), White Light Output 2,600 lumens, Colour Light Output 2,600 lumens, XGA Resolution, lightweight: less than 2 kgs. | 1 | unit | 3 |
| 33 | HDMI cable | 3 meters, v1.4A HDMI cable for Projector | 1 | pc | 3 |

Handwritten signature and initials

Procurement of CMU Boxes, Tools and Equipment and Mock-ups for the Mobile Training Laboratories (MTLs).

**TESDA Zamboanga del Norte Provincial Office
Olingan, Dipolog City Zamboanga del Norte**

| NO. | ITEM | AGENCY SPECS | QTY | UNIT | No. Of Box |
|--|----------------------------|--|-----|---------|------------|
| 34 | Whiteboard | wooden whiteboard (2' x 3') with frame, 1 meter collapsible high stand | 1 | pc | 3 |
| 35 | PA System | 550W Portable with Trolley, with 2 wireless mics, 220V, RCA port, with warranty | 1 | unit | 3 |
| 36 | Megaphone | with speak and music switch and volume control, 25w | 1 | unit | 3 |
| 37 | First Aid Kit | First Aid Kit with the contents: betadine, alcohol, adhesive strips, band-aid, disposable gloves, hypoallergenic medical tape (1.25 cm x 9.1m), conforming bandage (5cm), triangular bandage (110m x 110cm), wound dressing no. 15, swab antiseptic, tweezers metal 8 cm, scissors disposable, safety pins assorted (12 pcs), hot and cold compress pack, first aid quick reference guide. | 1 | package | 3 |
| Small Engine Repair (Motorcycle/Small Engine Servicing NC II) Tools and Equipment (for training purposes) | | | | | |
| 1 | Impact Drive Tool | 4pcs, 1/2" Impact Driver Set, heavy duty. | 10 | set | 4 |
| 2 | Multi-Tester | analog, standard-size analog multimeter for measuring voltage, current, and resistance. An auxiliary connector is also provided for checking transistors. Specifications: •DC Voltage Range: 0 to 1000V in seven ranges •AC Voltage Range: 0 to 1000V in five ranges •DC Current Range: 0 to 250mA in four ranges •Resistance Range: x1 to 20KW in four ranges •Transistor hFE Range: -0 to 1000 •Transistors Leakage Current (ICEO) Range: -0 to 150mAAF Output Range: -10dB to +22dB | 10 | pc | 4 |
| 3 | Oiler | metal case, 1/2 liter cap | 10 | pc | 4 |
| 4 | Steel Brush | wooden handle | 10 | pc | 4 |
| 5 | Hacksaw | adjustable hacksaw frame with bi-metal hacksaw blade, 24 TPI, aluminum alloy frame and handle | 10 | pc | 4 |
| 6 | Center Punch | high speed steel, 5x125 mm | 10 | pc | 4 |
| 7 | Cold Chisel | flat blade, 1" (W), 6" (L), hardened steel | 10 | pc | 4 |
| 8 | Fly Wheel/Magneto Puller | universal type, six in one fly wheel/ magneto puller | 10 | pc | 4 |
| 9 | Oil Seal Remover/Installer | pointed tip, hardened steel w/ straight handle, 3 pcs per set | 10 | set | 4 |
| 10 | Piston Ring Compressor | self locking w/ L wrench steel, range 2 1/8" to 5 inch diameter | 10 | pc | 4 |
| 11 | Valve Spring Compressor | spring loaded offset jaw overhead valve spring compressor, steel | 10 | pc | 4 |
| 12 | Clutch Assembly Remover | universal compressor clutch hub for removal and installation | 10 | pc | 4 |

Procurement of CMU Boxes, Tools and Equipment and Mock-ups for the Mobile Training Laboratories (MTLs).

**TESDA Zamboanga del Norte Provincial Office
Olingan, Dipolog City Zamboanga del Norte**

| NO. | ITEM | AGENCY SPECS | QTY | UNIT | No. Of Box |
|-----|------------------------|--|-----|------|------------|
| 13 | Electricians Plier | overall length 6, knife length: 5/8", material: carbon steel handle finished: plastic dipped | 10 | pc | 4 |
| 14 | Diagonal Cutting Plier | dyna grip, 152mm/6" inches carbon steel | 10 | pc | 4 |
| 15 | Mechanical Plier | 8", insulated handle | 10 | pc | 4 |
| 16 | Vise Gripped Plier | 10R straight jaw | 10 | pc | 4 |
| 17 | Feeler Gauge | 26 blade feeler gauge set, metric & English marked gauge | 10 | pc | 4 |
| 18 | Screwdriver, Flat | 8", magnetic tip, chrome vanadium, plastic handle | 10 | pc | 4 |
| 19 | Screwdriver, Philips | 8", magnetic tip, chrome vanadium, plastic handle | 10 | pc | 4 |
| 20 | Ballpeen hammer | 12 oz., 11 1/2" overall length forged steel construction, hardened and tempered, wooden handle | 10 | pc | 4 |
| 21 | Hammer, Brass/copper | 1 lb., wooden handle | 10 | pc | 4 |
| 22 | Hammer, Plastic | 1 lb, wooden handle, plastic tip hammer | 10 | pc | 4 |
| 23 | Wrench, Sparkplug | 19x16 mm, hexagonal w/ handle | 10 | pc | 4 |
| 24 | Wrench, Combination | 6mm,8mm,10mm,11mm,12mm,13mm,14mm,15mm,16mm,17mm,19mm,21mm,22mm,24 mm, chrome vanadium steel | 10 | set | 4 |
| 25 | Wrench, Socket | 8 - 32 mm., black, 1/2" drive | 10 | set | 4 |
| 26 | Wrench, T-type | 8, 10, 12, 14 mm | 10 | set | 4 |
| 27 | Hand Tractor Engine | diesel engine, single piston, 4 stroke direct injection, 10-12 hp | 2 | unit | 4 |
| 28 | Laptop | 15.6", Core i7, 1.40GHz, wide screen, 1TB hard drive, 8GB DDR3 memory, NVIDIA GTX 670MX graphic processor, 3GB video memory, Gigabit 10/100/1000Mbps IEEE802.11b/g/n Wireless LAN, web camera, HDMI, Bluetooth, USB2.0, USB3.0, with Windows 8 OS, up to 6 hours charge-in-use battery, DVDRW super Multi with 1 year warranty | 1 | unit | 4 |
| 29 | MS Office 2013 | Home & Student 1 user | 1 | unit | 4 |

Handwritten initials and a checkmark.

Procurement of CMU Boxes, Tools and Equipment and Mock-ups for the Mobile Training Laboratories (MTLs).

**TESDA Zamboanga del Norte Provincial Office
Olingan, Dipolog City Zamboanga del Norte**

| NO. | ITEM | AGENCY SPECS | QTY | UNIT | No. Of Box |
|-----|---------------|--|-----|---------|------------|
| 30 | Projector | LCD Projector Portable, RGB liquid crystal shutter projection system (3LCD), White Light Output 2,600 lumens, Colour Light Output 2,600 lumens, XGA Resolution, lightweight: less than 2 kgs. | 1 | unit | 4 |
| 31 | HDMI cable | 3 meters, v1.4A HDMI cable for Projector | 1 | pc | 4 |
| 32 | Whiteboard | wooden whiteboard (2' x 3') with frame, 1 meter collapsible high stand | 1 | pc | 4 |
| 33 | PA System | 550W Portable with Trolley, with 2 wireless mics, 220V, RCA port, with warranty | 1 | unit | 4 |
| 34 | Megaphone | with speak and music switch and volume control, 25w | 1 | unit | 4 |
| 35 | First Aid Kit | First Aid Kit with the contents: betadine, alcohol, adhesive strips, band-aid, disposable gloves, hypoallergenic medical tape (1.25 cm x 9.1m), conforming bandage (5cm), triangular bandage (110m x 110cm), wound dressing no. 15, swab antiseptic, tweezers metal 8 cm, scissors disposable, safety pins assorted (12 pcs), hot and cold compress pack, first aid quick reference guide. | 1 | package | 4 |

TIN
pd
AK

**Procurement of CMU Boxes, Tools and Equipment and Mock-ups for
the Mobile Training Laboratories (MTLs).**

**TESDA Zamboanga del Norte Provincial Office
Olingan, Dipolog City Zamboanga del Norte**

| Lot No. | Item / Description | Qty. | Unit | No. of Mock-up |
|--|---|------|-------|----------------|
| Electrical Installation and Maintenance (EIM) NC II Mock-up | | | | |
| 1 | Electrical Installation Maintenance (EIM) Mock-Up | 1 | lot | 1 |
| SUPPLIES AND MATERIALS | | | | |
| 2 | Heat gun, 1200 watts | 1 | pc | 1 |
| 3 | PVC adapter with lock nuts | 20 | pc | 1 |
| 4 | Circuit breaker, 30A | 2 | pc | 1 |
| 5 | 1/2" diameter PVC pipe | 2 | meter | 1 |
| 6 | Cable ties, 100 pcs./pack | 1 | pack | 1 |
| 7 | Incandescent bulb, 220V, 25W | 5 | pc | 1 |
| 8 | One pole switch with plate, flush type | 5 | pc | 1 |
| 9 | Three way switch with plate, flush type | 5 | pc | 1 |
| 10 | Four way switch with plate, flush type | 5 | pc | 1 |
| 11 | Lamp receptacle 4" X 4" surface type | 5 | pc | 1 |
| 12 | Photo electrical (photocell) | 1 | pc | 1 |
| 13 | Convenience outlet, universal type | 5 | pc | 1 |
| 14 | Floor outlet, round type | 1 | pc | 1 |
| 15 | Ground fault current interrupter | 1 | pc | 1 |
| 16 | Circuit breaker 60A with built in housing | 1 | pc | 1 |
| 17 | Terminal block 15A 12 slots | 40 | pc | 1 |
| 18 | Automotive Wire #14 AWG (1 solid and 1 stranded) | 2 | roll | 1 |
| 19 | Terminal lug, Y type | 150 | pc | 1 |
| This include supplies and materials required in the fabrication of mock-up | | | | |
| Plumbing NC II Mock-up | | | | |
| 1 | Plumbing Mock-up (Labor Cost) | 1 | lot | 1 |
| SUPPLIES AND MATERIALS | | | | |
| 2 | 4" dia PVC Pipe (Orange) | 1 | pc | 1 |
| 3 | 4" dia. PVC Elbow 90 deg. | 1 | pc | 1 |
| 4 | 4" dia. PVC Elbow 45 deg. | 1 | pc | 1 |
| 5 | 4" dia. PVC Clean Out | 1 | pc | 1 |
| 6 | 4" x 3" PVC Wye | 1 | pc | 1 |
| 7 | 4" x 2" PVC Wye | 3 | pc | 1 |
| 8 | 3" dia. PVC pipe | 1 | pc | 1 |
| 9 | 3" PVC Elbow | 1 | pc | 1 |
| 10 | 3" PVC Elbow 45 deg. | 1 | pc | 1 |
| 11 | 3" x 2" PVC Tee | 1 | pc | 1 |
| 12 | 3" x 3" PVC Tee | 1 | pc | 1 |
| 13 | 2" dia PVC Pipe | 2 | pc | 1 |
| 14 | 2" dia. PVC Elbow 45 deg. | 3 | pc | 1 |
| 15 | 2" dia. PVC Elbow 90 deg. | 3 | pc | 1 |
| 16 | 2" PVC Tee | 4 | pc | 1 |
| 17 | 2" PVC P-trap | 2 | pc | 1 |
| 18 | 1/2" dia. PPr pipe | 2 | pc | 1 |
| 19 | 1/2" dia. PPr elbow | 7 | pc | 1 |
| 20 | 1/2" dia. PPr tee | 4 | pc | 1 |
| 21 | 1/2" dia. PPr elbow connector | 6 | pc | 1 |
| 22 | 1/2" dia. PPr male connector | 2 | pc | 1 |
| 23 | 1/2" dia. PPr union | 3 | pc | 1 |
| 24 | 1/2" dia. PPr coupling | 4 | pc | 1 |

PN
pd
abx

**Procurement of CMU Boxes, Tools and Equipment and Mock-ups for
the Mobile Training Laboratories (MTLs).**

**TESDA Zamboanga del Norte Provincial Office
Olingan, Dipolog City Zamboanga del Norte**

| Lot No. | Item / Description | Qty. | Unit | No. of Mock-up |
|--|--|------|-------|----------------|
| 25 | Urinal 480mm X 730mm X 730mm with complete accessories | 1 | unit | 1 |
| 26 | Shower head with complete accessories | 1 | unit | 1 |
| 27 | 1/2 x 7/8 flexible hose | 1 | pc | 1 |
| 28 | 1/2 x 1/2" angle valve | 3 | pc | 1 |
| 29 | 3/4" x 4' x 8' Marine Plywood | 1 | pc | 1 |
| 30 | 2" x 2" x 12' Lumber | 4 | pc | 1 |
| 31 | Teflon Tape | 10 | pc | 1 |
| 32 | Metal hinges 2" X 4", heavy duty | 3 | pc | 1 |
| This include supplies and materials required in the fabrication of mock-up | | | | |
| Small Engine Repair (Motorcycle/Small Engine Servicing NC II) Tools and Equipment Mock-up | | | | |
| 1 | Motorcycle/Small Engine Collapsible Mock-Up | 1 | lot | 1 |
| SUPPLIES AND MATERIALS: | | | | |
| 2 | Auto wire, stranded # 16 | 1 | roll | 1 |
| 3 | Electrical tape, large black | 2 | pc | 1 |
| 4 | Head light assembly, 12 volts rectangular | 1 | pc | 1 |
| 5 | signal light assembly, 12 volts | 2 | pair | 1 |
| 6 | Horn, 12 volts | 1 | pc | 1 |
| 7 | Stop light switch, push button | 1 | pc | 1 |
| 8 | Signal light switch, double throw, toggle switch | 1 | pc | 1 |
| 9 | Ignition switch, gas engine type | 1 | pc | 1 |
| 10 | Signal light relay, 12 volts | 1 | pc | 1 |
| 11 | Push button switch for horn | 1 | pc | 1 |
| 12 | Motorcycle storage battery, 12 volts maintenance free | 1 | pc | 1 |
| 13 | Harness cover, 3/8" diameter (140/4) | 4 | meter | 1 |
| 14 | Harness connector, 6 terminals | 4 | pc | 1 |
| 15 | Male terminal, flat | 30 | pc | 1 |
| 16 | Female terminal, flat | 30 | pc | 1 |
| 17 | Headlight switch or toggle switch, single throw | 1 | pc | 1 |
| 18 | Crocodile clip, medium, red and black | 1 | pair | 1 |
| 19 | 3/16" diameter X 3/4" stove bolt, stainless | 20 | pc | 1 |
| 20 | 3/16" diameter hole, eye terminal | 10 | pc | 1 |
| 21 | Four stroke motorcycle engine, 125 or 155cc, surplus | 1 | unit | 1 |
| This include supplies and materials required in the fabrication of mock-up | | | | |

4
af

Procurement of CMU Boxes, Tools and Equipment and Mock-ups for the Mobile Training Laboratories (MTLs).

**TESDA Camiguin Provincial Office
Mabini St. Poblacion Mambajao, Camiguin**

| NO. | ITEM | AGENCY SPECS | QTY | UNIT | No. Of Box |
|---|--|---|-----|------|------------|
| Appliance Repair NC II Tools and Equipment (for training purposes) | | | | | |
| 1 | Soldering Iron | dual wattage, 25 watts/ 120watts, 220 volt 60 Hz, with long life tip, "gun type" | 25 | unit | 3 |
| 2 | Desoldering Tools | desoldering pump with precision regulated return, replacement tip compact, metal housing | 25 | unit | 3 |
| 3 | Screw driver assorted (Phillips and slotted) | 12x7x1 inches, 6 pieces per set, plastic handle | 5 | set | 3 |
| 4 | Long Nose Plier | dyna grip, 152mm/6" inches carbon steel | 5 | pc | 3 |
| 5 | Diagonal Cutting Plier | dyna grip, 152mm/6" inches carbon steel | 5 | pc | 3 |
| 6 | Nut Drivers | rust-resistant, nickel-plated bar, hexagonal shank, includes: 5mm, 6mm, 7mm, 8mm, 9mm, 10mm, 11mm | 5 | set | 3 |
| 7 | Wrench, Combination | 6mm,8mm,10mm,11mm,12mm,13mm,14mm,15mm, 16mm,17mm,19mm, 21mm,22mm, 24 mm, chrome vanadium steel | 5 | set | 3 |
| 8 | Wire Stripper | automatic, cap. 1.5mm to 3.5mm | 10 | pc | 3 |
| 9 | Ballpeen hammer | 12 oz., 11 1/2" overall length forged steel construction, hardened and tempered, wooden handle | 5 | pc | 3 |
| 10 | Flashlight | LED, 3 volts/6 volts, rechargeable | 5 | pc | 3 |
| 11 | Detector Light | test light, 220 volts | 5 | pc | 3 |
| 12 | Paint Brush | 4 inches width, wooden handle | 25 | pc | 3 |
| 13 | Microwave Oven | power capacity: 220V 1300 watts, interior capacity 20 liters, 8 programmes, defrost option, 26cm diameter rotating turntable, digital | 1 | unit | 3 |
| 14 | Washing Machine with dryer | power capacity: 500w, 220V, rust proof body, gear drive system, dolphin drive pulsator, washing capacity (dry weight) 7.5kg, spinning capacity (dry weight) 5.5kg, width should be more than 50 cm and length of not more than 100 cm | 1 | unit | 3 |
| 15 | Electric Fan | power capacity: 220V, 100w, 60Hz, 3 speed rotary switch, 18 inch metal blade, round/stable plastic base, thermal fuse protection, adjustable height stand fan | 1 | unit | 3 |
| 16 | Electric Rice Cooker | power capacity: 700w, 220V, 60Hz, automatic cooking feature, auto shutoff, glass lid, non-stick coated aluminum pan, includes measuring cup and rice scoop | 1 | unit | 3 |

Handwritten marks:
T
N
pb

Procurement of CMU Boxes, Tools and Equipment and Mock-ups for the Mobile Training Laboratories (MTLs).

**TESDA Camiguin Provincial Office
Mabini St. Poblacion Mambajao, Camiguin**

| NO. | ITEM | AGENCY SPECS | QTY | UNIT | No. Of Box |
|-----|--------------------|--|-----|------|------------|
| 17 | Electric Flat Iron | power capacity:1000w, 220V, 60 Hz, non-stick Teflon soleplate, thermal fuse protected, variable temperature control, automatic thermostat Control, pilot lamp indicator | 1 | unit | 3 |
| 18 | Coffee Maker | power capacity: 550w, 220V, 60Hz, glass pitcher, anti-drip feature, 6 cup water capacity, water level indicator, swing-out filter basket | 1 | unit | 3 |
| 19 | Oven Toaster | power capacity: 1000w, 220V, 60Hz, stainless steel, 8 liter capacity, 15 minute timer, slide out chrome crumb rack, includes baking tray | 1 | unit | 3 |
| 20 | Blender | 1.5 liter capacity, rated voltage, 230V, 60Hz, power consumption: 300 watts, sharp stainless steel blade, safety lock switch, with plastic stirrer for easy mixing | 1 | unit | 3 |
| 21 | Multi Tester | analog, standard size analog multimeter for measuring voltage, current and resistance. An auxiliary connector is also provided for checking transistors. SPECIFICATION: <ul style="list-style-type: none"> •DC Voltage Range: 0 to 1000V in seven ranges •AC Voltage Range: 0 to 1000V in five ranges •DC Current Range: 0 to 250mA in four ranges •Resistance Range: x1 to 200MEG in four ranges •Transistor hFE Range: -0 to 1000 •Transistors Leakage Current (ICEO) Range: -0 to 150mAAF •Output Range: -10dB to +22dB | 25 | unit | 3 |
| 22 | Multi Tester | Digital Multi meters are standard digital multimeter for measuring voltage, current, and resistance with 3-1/2 digit LCD display. This meter measures only 138mm x 70mm x 32mm and weighs approximately 140 grams, including battery. SPECIFICATION: <ul style="list-style-type: none"> •DC Voltage Range: 200mV to 600V in five ranges (auto ranging) •AC Voltage Range: 2V to 600V in four ranges (auto ranging) •DC Current Range: 200mA to 10A in six ranges •Resistance Range: 200 Ohms to 20M in six ranges •Transistor hFE Test Range: 0 to 2000 | 25 | unit | 3 |
| 23 | Laptop | 15.6", Core i7, 1.40GHz, wide screen, 1TB hard drive, 8GB DDR3 memory, NVIDIA GTX 670MX graphic processor, 3GB video memory, Gigabit 10/100/1000Mbps IEEE802.11b/g/n Wireless LAN, web camera, HDMI, Bluetooth, USB2.0, USB3.0, with Windows 8 OS, up to 6 hours charge-in-use battery, DVDRW super Multi with 1 year warranty | 1 | unit | 3 |

1
2
3

Procurement of CMU Boxes, Tools and Equipment and Mock-ups for the Mobile Training Laboratories (MTLs).

**TESDA Camiguin Provincial Office
Mabini St. Poblacion Mambajao, Camiguin**

| NO. | ITEM | AGENCY SPECS | QTY | UNIT | No. Of Box |
|---|-----------------------|--|-----|---------|------------|
| 24 | MS Office 2013 | Home & Student 1 user | 1 | unit | 3 |
| 25 | Projector | LCD Projector Portable, RGB liquid crystal shutter projection system (3LCD), White Light Output 2,600 lumens, Colour Light Output 2,600 lumens, XGA Resolution, lightweight: less than 2 kgs. | 1 | unit | 3 |
| 26 | HDMI cable | 3 meters, v1.4A HDMI cable for Projector | 1 | pc | 3 |
| 27 | Whiteboard | wooden whiteboard (2' x 3') with frame, 1 meter collapsible high stand | 1 | pc | 3 |
| 28 | PA System | 550W Portable with Trolley, with 2 wireless mics, 220V, RCA port, with warranty | 1 | unit | 3 |
| 29 | Megaphone | with speak and music switch and volume control, 25w | 1 | unit | 3 |
| 30 | First Aid Kit | First Aid Kit with the contents: betadine, alcohol, adhesive strips, band-aid, disposable gloves, hypoallergenic medical tape (1.25 cm x 9.1m), conforming bandage (5cm), triangular bandage (110m x 110cm), wound dressing no. 15, swab antiseptic, tweezers metal 8 cm, scissors disposable, safety pins assorted (12 pcs), hot and cold compress pack, first aid quick reference guide. | 1 | package | 3 |
| Bread and Pastry NC II Tools and Equipment (for training purposes) | | | | | |
| 1 | Measuring Cup, dry | stainless steel, 4 pcs/set (1c, 1/2c, 1/3c & 1/4c) | 12 | pc | 3 |
| 2 | Measuring Cup, liquid | glass graduated, 250 ml capacity | 12 | pc | 3 |
| 3 | Measuring Spoon | Stainless steel 6 pcs/set(1/8 tsp, 1/4 tsp, 1/2tsp, 1 tsp 1/2 tbsp, 1 tbsp) | 12 | set | 3 |
| 4 | Cake Turn Table | plastic cake turntable with locking switch, rubberized feet, white, 12.6x12.6x3.54 inches (LxWxH) | 10 | pc | 3 |
| 5 | Decorating Tips | stainless steel, 24-piece cake decorating tip set, package size: 17cm x 12cm x 5cm (6.69 x 4.72 x 1.97inches) | 25 | set | 3 |
| 6 | Rolling Pin | wooden, size 33.5 x 5cm, light weight comfortable grip | 25 | pc | 3 |
| 7 | Pie Plate, size 6" | aluminum pie pan, 6" diameter x 5/8 in deep, heavy weight round pan | 10 | pc | 3 |
| 8 | Pie Plate, size 8" | pie pan, 8" aluminum deep dish pie pan, standard weight aluminum, 8" top outside diameter | 10 | pc | 3 |
| 9 | Pie Plate, size 10" | deep aluminum pie pan, 10" diameter, depth 1-1/4", made of 0.7mm thick satin finished aluminum | 10 | pc | 3 |
| 10 | Jelly Roll Pan | aluminum, dimension: 2" x 13 x 8' (HxWxD) | 10 | pc | 3 |

7
N
25 96

Procurement of CMU Boxes, Tools and Equipment and Mock-ups for the Mobile Training Laboratories (MTLs).

**TESDA Camiguin Provincial Office
Mabini St. Poblacion Mambajao, Camiguin**

| NO. | ITEM | AGENCY SPECS | QTY | UNIT | No. Of Box |
|-----|----------------------|--|-----|------|------------|
| 11 | Cake Spring Form Pan | heavy aluminum spring form pan, heavy duty frame, spring form sides for easy removal, size 9 x 3" | 10 | pc | 3 |
| 12 | Pie Cutter | triple riveted pizza cutter, made of stainless steel, rolling wheel slicer, 6" | 10 | pc | 3 |
| 13 | Rubber Scraper | rubber head, high heat resistant, flexible, 12", color white | 25 | pc | 3 |
| 14 | Spatula | Stainless steel straight blade, 14 inches long with wood handle | 25 | pc | 3 |
| 15 | Cake Stand with tier | 3 tier cake round acrylic cake stand, 3 plates clear, size: 15cm, 20cm, 25cm, 10 inches gap between each tier | 6 | set | 3 |
| 16 | Saucepan | Stainless steel with cover and handle 26cm | 15 | pc | 3 |
| 17 | Ladle | stainless steel, 12 inches, comes with brush finished handle, hole in the handle for easy hanging | 10 | pc | 3 |
| 18 | Chef Knife | 8 inch, stainless steel full tang blade with plastic handle | 12 | pc | 3 |
| 19 | Chopping Board | 12 x 17 inches, polyethylene, easy grip handle, white color | 10 | pc | 3 |
| 20 | Weighing Scale | manual, maximum weight capacity 2kg, graduated by grams, removable and washable tray | 6 | pc | 3 |
| 21 | Grater | made of nonreactive stainless steel easy grip handle | 10 | pc | 3 |
| 22 | Wooden Spoon | wooden turner, size 12 inches | 25 | pc | 3 |
| 23 | Piping Bag | 12 inches, light weight, reusable, flexible polyester, coated can be boiled, dishwasher safe | 25 | pc | 3 |
| 24 | Mixing Bowl | 12 inches diameter, 8-9 quarts capacity, stainless | 15 | pc | 3 |
| 25 | Wire Whisk | 8"/20cm, aluminum, balloon style | 25 | pc | 3 |
| 26 | Electric Mixer | 4 qt. stainless steel bowl, 5 speeds & quick burst button, bowl rest TM mixer stabilizer, doubles as a hand mixer, 220V, 290-watts peak power, versatile attachment set includes traditional beaters, whisk and dough hooks, brushed stainless steel | 5 | unit | 3 |
| 27 | Dough Cutter | dough scraper 6" wide x 4", high polished stainless steel blade | 10 | pc | 3 |
| 28 | Oven (gas) | stainless door, 2 trays oven with tempered glass window, 22-25" collapsible stand | 1 | unit | 3 |
| 29 | Pastry Brush | pastry/basting brush, natural wood handle brushes, 1.5" size | 10 | pc | 3 |
| 30 | Bread Knife | 8", serrated edge stain free high-carbon steel blade texture red polypropylene handle | 10 | pc | 3 |

7
96
W
af

Procurement of CMU Boxes, Tools and Equipment and Mock-ups for the Mobile Training Laboratories (MTLs).

**TESDA Camiguin Provincial Office
Mabini St. Poblacion Mambajao, Camiguin**

| NO. | ITEM | AGENCY SPECS | QTY | UNIT | No. Of Box |
|--|---------------------|--|-----|---------|------------|
| 31 | Flour Sifter | stainless steel mesh flour sifter strainer, 12" | 10 | pc | 3 |
| 32 | Baking Sheet | aluminum , 13" x 18" | 15 | pc | 3 |
| 33 | Muffin Pans | 12 holes, 3 oz. capacity per holes, aluminum | 25 | pc | 3 |
| 34 | Working Table | high quality stainless steel foldable tables dimension: 3ft x 3ft | 4 | pc | 3 |
| 35 | Gas Stove with tank | 2 burner, made from stainless top body, automatic ignition, with complete accessories | 2 | pc | 3 |
| 36 | Kitchen Sink | Kitchen sink, portable single bowl sink stainless steel, with steel collapsible frame legs, with drain hose, Dimension 50cmx50cmx30cm | 1 | pc | 3 |
| 37 | Weighing Scale | digital, 1000g, maximum weight capacity, battery operated (AAA battery) 0.1 g to 1000g , LCD display battery included. | 5 | pc | 3 |
| 38 | Laptop | 15.6", Core i7, 1.40GHz, wide screen, 1TB hard drive, 8GB DDR3 memory, NVIDIA GTX 670MX graphic processor, 3GB video memory, Gigabit 10/100/1000Mbps IEEE802.11b/g/n Wireless LAN, web camera, HDMI, Bluetooth, USB2.0, USB3.0, with Windows 8 OS, up to 6 hours charge-in-use battery, DVDRW super Multi with 1 year warranty | 1 | unit | 3 |
| 39 | MS Office 2013 | Home & Student 1 user | 1 | unit | 3 |
| 40 | Projector | LCD Projector Portable, RGB liquid crystal shutter projection system (3LCD), White Light Output 2,600 lumens, Colour Light Output 2,600 lumens, XGA Resolution, lightweight: less than 2 kgs. | 1 | unit | 3 |
| 41 | HDMI cable | 3 meters, v1.4A HDMI cable for Projector | 1 | pc | 3 |
| 42 | Whiteboard | wooden whiteboard (2' x 3') with frame, 1 meter collapsible high stand | 1 | pc | 3 |
| 43 | PA System | 550W Portable with Trolley, with 2 wireless mics, 220V, RCA port, with warranty | 1 | unit | 3 |
| 44 | Megaphone | with speak and music switch and volume control, 25w | 1 | unit | 3 |
| 45 | First Aid Kit | First Aid Kit with the contents: betadine, alcohol, adhesive strips, band-aid, disposable gloves, hypoallergenic medical tape (1.25 cm x 9.1m), conforming bandage (5cm), triangular bandage (110m x 110cm), wound dressing no. 15, swab antiseptic, tweezers metal 8 cm, scissors disposable, safety pins assorted (12 pcs), hot and cold compress pack, first aid quick reference guide. | 1 | package | 3 |
| Cookery NC II Tools and Equipment (for training purposes) | | | | | |
| 1 | Chef Knife | 8 inch, stainless steel full tang blade with plastic handle | 10 | pc | 3 |

T
N
48 96

Procurement of CMU Boxes, Tools and Equipment and Mock-ups for the Mobile Training Laboratories (MTLs).

**TESDA Camiguin Provincial Office
Mabini St. Poblacion Mambajao, Camiguin**

| NO. | ITEM | AGENCY SPECS | QTY | UNIT | No. Of Box |
|-----|--------------------------|--|-----|------|------------|
| 2 | Boning Knife | 6 inches, stainless steel with sharp cutting edge with plastic handle | 8 | pc | 3 |
| 3 | Oyster Knife | 7 inches length (3 inches blade and 4 inches handle), stainless steel blade, with comfortable plastic handle | 4 | pc | 3 |
| 4 | Cleaver Knife | 7 inches, stain resistant carbon steel blade | 2 | pc | 3 |
| 5 | Tenderizer | with flat and textured side, non slip, 10 inches 25.5 cm, solid aluminum construction | 8 | pc | 3 |
| 6 | Skimmer | fine, extra fine mesh, 6 inches diameter, with stainless handle | 8 | pc | 3 |
| 7 | Wire Skimmer | small, nickel plated wire oil skimmer, 16 inches long overall, 5 inches diameter bowl | 8 | pc | 3 |
| 8 | Skimmer | spider, 5 inches diameter, natural bamboo handle, constructed of durable stainless steel with versatile woven design | 8 | pc | 3 |
| 9 | Strainer, small | fine, 6" diameter, with stainless handle | 8 | pc | 3 |
| 10 | Siever | small 12" diameter, stainless | 8 | pc | 3 |
| 11 | Strainer, medium | medium, fine stainless steel mesh, 9 inches diameter with stainless handle | 8 | pc | 3 |
| 12 | Turner | solid, stainless steel, with handy loop for hanging, 12 inches long | 8 | pc | 3 |
| 13 | Spatula | Stainless steel straight blade, 14 inches long with wood handle | 8 | pc | 3 |
| 14 | Wooden Spatula | large comfortable handle, 12 inches long, wooden | 8 | pc | 3 |
| 15 | Piping Bag | 12 inches, light weight, reusable, flexible polyester, coated, can be boiled, dishwasher safe | 8 | pc | 3 |
| 16 | Pastry Tubes | steel stainless, set of 24 pcs, different/assorted icing nozzles medium size, constructed of 18/8 quality stainless steel, comes in plastic storage box with lid | 8 | set | 3 |
| 17 | Strainer, chinois medium | medium, 8 inches diameter, stainless steel including handle | 3 | pc | 3 |
| 18 | Strainer, chinois small | small, 5 inches diameter, stainless steel including handle | 2 | pc | 3 |
| 19 | Funnel | general purpose, hard plastic, comes in 4 different sizes (small, medium, large, extra large) | 4 | set | 3 |
| 20 | Measuring Spoon | Stainless steel 6 pcs/set (1/8 tsp, 1/4 tsp, 1/2 tsp, 1 tsp, 1/2 tbsp, 1 tbsp) | 6 | set | 3 |
| 21 | Food Tong | 12 inches long, stainless steel, and wide shell head with locking | 8 | pc | 3 |
| 22 | Measuring Cup, liquid | glass graduated, 250 ml capacity | 8 | pc | 3 |
| 23 | Ice Cream Scooper | set of three, stainless steel (2 oz, 4 oz and 6 oz) | 2 | set | 3 |

TN
96
of

Procurement of CMU Boxes, Tools and Equipment and Mock-ups for the Mobile Training Laboratories (MTLs).

**TESDA Camiguin Provincial Office
Mabini St. Poblacion Mambajao, Camiguin**

| NO. | ITEM | AGENCY SPECS | QTY | UNIT | No. Of Box |
|-----|------------------------|--|-----|------|------------|
| 24 | Cheese Cloth | 100% cotton 1 yard | 10 | pc | 3 |
| 25 | Serving Spoon | stainless steel , 9 inches long | 24 | pc | 3 |
| 26 | Pepper and Salt Mill | 2 in 1, wooden, 8" | 4 | pc | 3 |
| 27 | Weighing Scale | analog weighing scale ; maximum weight capacity , 5 kg, graduated by grams , removable and washable tray | 2 | unit | 3 |
| 28 | Weighing Scale | digital, 1000g, maximum weight capacity, battery operated (AAA battery) 0.1 g to 1000g , LCD display battery included. | 2 | unit | 3 |
| 29 | Apple Corer | corer head comfortable on slip handle, corer head is stainless steel | 4 | pc | 3 |
| 30 | Wire Whisk | 8"/20cm, aluminum, balloon style | 8 | pc | 3 |
| 31 | Wire Whisk, medium | medium, 10 inches/25 cm, aluminum, balloon style | 8 | pc | 3 |
| 32 | Wire Whisk, large | heavy duty, stainless steel, 14 inches, balloon style | 2 | pc | 3 |
| 33 | Measuring Cup, dry | stainless steel, 4 pcs/set (1c , 1/2c, 1/3c & 1/4c) | 1 | set | 3 |
| 34 | Chopping Board | 12 x17 inches, polyethylene, easy grip handle, white color | 10 | pc | 3 |
| 35 | Kitchen Scissors | stainless steel blade, size 2 cm x 12 cm x 27 cm, durable and sturdy handle with comfortable grip | 8 | pc | 3 |
| 36 | Soup Ladle | 3 oz capacity, stainless steel, with handle, round bottom | 8 | pc | 3 |
| 37 | Soup Ladle | 6 oz capacity, stainless steel handle, round bottom | 8 | pc | 3 |
| 38 | Soup Ladle | 8 oz capacity, stainless steel handle, round bottom | 3 | pc | 3 |
| 39 | Soup Ladle | 12 oz capacity, stainless handle, round bottom, | 2 | pc | 3 |
| 40 | Mixing Bowl | 12 inches diameter, 8-9 quarts capacity , stainless | 10 | pc | 3 |
| 41 | Kitchen Spoon | solid, stainless steel handle, comfortable non slip handle, round handle 4.5 x2.5 inches | 8 | pc | 3 |
| 42 | Kitchen Spoon | slotted, stainless steel, comfortable non slip handle, round handle 10 x 2.5 inches w/ hole | 8 | pc | 3 |
| 43 | Kitchen Fork | 7.5 cm x 4.5 cm x 37 cm or 10.5 inches, stainless steel, with 2 prongs, round handle | 8 | pc | 3 |
| 44 | Carving Fork | 10.5 inches, stainless steel, with 2 prongs, round handle | 3 | pc | 3 |
| 45 | Pocket Pin Thermometer | analog, temperature range from 0oF to 220 of, dial type | 3 | pc | 3 |
| 46 | Peeler | Straight blade type, dual stainless steel blade, metal handle 5",2"handle,3"blade | 8 | pc | 3 |

7
12
MA

Procurement of CMU Boxes, Tools and Equipment and Mock-ups for the Mobile Training Laboratories (MTLs).

**TESDA Camiguin Provincial Office
Mabini St. Poblacion Mambajao, Camiguin**

| NO. | ITEM | AGENCY SPECS | QTY | UNIT | No. Of Box |
|-----|---------------------|--|-----|------|------------|
| 47 | Stockpot | stainless, 17 quarts capacity (22.7 lit), 12 inches diameter (30.5 cm), depth 31 cm, 4 mm thickness | 2 | pc | 3 |
| 48 | Frying pan | pan, large, non stick, 26 cm diameter | 2 | pc | 3 |
| 49 | Colander | medium, stainless steel, 8 quarts capacity, with base | 2 | pc | 3 |
| 50 | Fish Poacher | medium, 18 inches (L) and 6 inches (w), stainless steel, with handle | 1 | pc | 3 |
| 51 | Casserole | small, stainless steel, 20 cm diameter, with cover | 8 | pc | 3 |
| 52 | Casserole | medium, stainless steel, 24 cm diameter with cover | 4 | pc | 3 |
| 53 | Double Boiler | medium, made from stainless steel, 2 quarts capacity, with lid cover | 1 | pc | 3 |
| 54 | Paellara | 40 cm diameter, (50 cm with handle), constructed of carbon steel, riveted secure melt handle, safe for all heating surfaces including induction | 4 | pc | 3 |
| 55 | Baking Tray | small, main material is carbon, rectangular, size 14 x 10 inches | 8 | pc | 3 |
| 56 | Utility Tray | hard plastic tray, rectangular 14x18 inches | 12 | pc | 3 |
| 57 | Fire Extinguisher | cylinder type, multipurpose ABC dry chemical, powder aluminum valve coated, rechargeable, 5 lbs capacity, with pressure gauge that allows for immediate pressure status check, with wall hanger, meets requirements for underwriter laboratory (UJ) | 1 | unit | 3 |
| 58 | Blender | 1.5 liter capacity, rated voltage, 230V, 60Hz, power consumption: 300 watts, sharp stainless steel blade, safety lock switch, with plastic stirrer for easy mixing | 1 | unit | 3 |
| 59 | Pressure Cooker | aluminum, 2 mm, 6 quarts capacity, pressured handle, central pressure valve with self locking mechanism | 1 | pc | 3 |
| 60 | Gas Stove with tank | 2 burner, made from stainless top body, automatic ignition, with complete accessories | 4 | unit | 3 |
| 61 | Working Table | high quality stainless steel foldable tables dimension: 3ft x 3ft | 4 | pc | 3 |
| 62 | Kitchen Sink | Kitchen sink, portable single bowl sink stainless steel, with steel collapsible frame legs, with drain hose, Dimension 50cmx50cmx30cm | 1 | unit | 3 |
| 63 | Laptop | 15.6", Core i7, 1.40GHz, wide screen, 1TB hard drive, 8GB DDR3 memory, NVIDIA GTX 670MX graphic processor, 3GB video memory, Gigabit 10/100/1000Mbps IEEE802.11b/g/n Wireless LAN, web camera, HDMI, Bluetooth, USB2.0, USB3.0, with Windows 8 OS, up to 6 hours charge-in-use battery, DVDRW super Multi with 1 year warranty | 1 | unit | 3 |

7
N
Pb
at

Procurement of CMU Boxes, Tools and Equipment and Mock-ups for the Mobile Training Laboratories (MTLs).

**TESDA Camiguin Provincial Office
Mabini St. Poblacion Mambajao, Camiguin**

| NO. | ITEM | AGENCY SPECS | QTY | UNIT | No. Of Box |
|--|-----------------------|--|-----|---------|------------|
| 64 | MS Office 2013 | Home & Student 1 user | 1 | unit | 3 |
| 65 | Projector | LCD Projector Portable, RGB liquid crystal shutter projection system (3LCD), White Light Output 2,600 lumens, Colour Light Output 2,600 lumens, XGA Resolution, lightweight: less than 2 kgs. | 1 | unit | 3 |
| 66 | HDMI cable | 3 meters, v1.4A HDMI cable for Projector | 1 | pc | 3 |
| 67 | Whiteboard | wooden whiteboard (2' x 3') with frame, 1 meter collapsible high stand | 1 | pc | 3 |
| 68 | PA System | 550W Portable with Trolley, with 2 wireless mics, 220V, RCA port, with warranty | 1 | unit | 3 |
| 69 | Megaphone | with speak and music switch and volume control, 25w | 1 | unit | 3 |
| 70 | First Aid Kit | First Aid Kit with the contents: betadine, alcohol, adhesive strips, band-aid, disposable gloves, hypoallergenic medical tape (1.25 cm x 9.1m), conforming bandage (5cm), triangular bandage (110m x 110cm), wound dressing no. 15, swab antiseptic, tweezers metal 8 cm, scissors disposable, safety pins assorted (12 pcs), hot and cold compress pack, first aid quick reference guide. | 1 | package | 3 |
| Food Processing NC II Tools and Equipment (for training purposes) | | | | | |
| 1 | Weighing Scale | Manual weighing scale; maximum weight capacity, 5 kg. graduated by grams, removable and washable tray | 5 | unit | 3 |
| 2 | Weighing Scale | digital, 1000g, maximum weight capacity, battery operated (AAA battery) 0.1 g to 1000g, LCD display battery included. | 5 | unit | 3 |
| 3 | Paring Knives | stainless steel blade, 4 inches | 25 | pc | 3 |
| 4 | Peeler | Straight blade type, dual stainless steel blade, metal handle 5", 2" handle, 3" blade | 12 | pc | 3 |
| 5 | Measuring Spoon | Stainless steel 6 pcs/set (1/8 tsp, 1/4 tsp, 1/2 tsp, 1 tsp 1/2 tbsp, 1 tbsp) | 6 | set | 3 |
| 6 | Measuring Cup, dry | stainless steel, 4 pcs/set (1c, 1/2c, 1/3c & 1/4c) | 6 | set | 3 |
| 7 | Measuring Cup, liquid | glass graduated, 250 ml capacity | 6 | pc | 3 |
| 8 | Clocks/Timer | digital, battery operated, with convenient clip, battery included. | 5 | pc | 3 |
| 9 | Mixing Bowl | 12 inches diameter, 8-9 quarts capacity, stainless | 12 | set | 3 |
| 10 | Chopping Board | 12x17 inches, polyethylene, easy grip handle, white color | 3 | set | 3 |
| 11 | Dial Thermometer | stainless steel, 12" stem, stainless clip | 5 | pc | 3 |
| 12 | Osterizers | 8 speed with pulse, 500 watts, 220 volts 60 hertz, stainless steel ice crusher blade, 6 cups glass jar capacity, with warranty. | 4 | unit | 3 |
| 13 | Jar Lifter | non slip handle, rubberized 5" full expansion | 5 | pc | 3 |
| 14 | Food Processors | with exact slice system, 2 in one wide mouth feed tube, with high, low, pulse, off operation, adjustable stainless steel slicing disc and ultra tight seal, 220 volts, 60 hertz, 700 watts | 1 | unit | 3 |

Procurement of CMU Boxes, Tools and Equipment and Mock-ups for the Mobile Training Laboratories (MTLs).

**TESDA Camiguin Provincial Office
Mabini St. Poblacion Mambajao, Camiguin**

| NO. | ITEM | AGENCY SPECS | QTY | UNIT | No. Of Box |
|-----|-----------------------------|--|-----|------|------------|
| 15 | Wire Baskets | stainless steel, rectangular, with handle, 4" x 17.75" x 14" (HxWxD) | 5 | pc | 3 |
| 16 | Casseroles | stainless steel, with cover, 5 quarts capacity, with long handles | 5 | pc | 3 |
| 17 | Saucepan | stainless steel, with cover and handle, 26 cm | 5 | pc | 3 |
| 18 | Spoon, wooden | wooden turner; size 12 inches | 15 | pc | 3 |
| 19 | Spoon, basting | 12" long, 100% solid wood, strong and durable. | 15 | pc | 3 |
| 20 | Paddle, wooden | solid wood, 24 inches length x 3-1/2 inches width | 4 | pc | 3 |
| 21 | Food Tong | 12 inches long, stainless steel, and wide shell head with locking | 14 | pc | 3 |
| 22 | Kitchen Scissors | stainless steel blade, size 2 cm x 12 cm x 27 cm, durable and sturdy handle with comfortable grip | 12 | pc | 3 |
| 23 | Steamer | 6 quarts base pan doubles as a stock pot, aluminum, with cover, 3 layer, 30 cm | 4 | pc | 3 |
| 24 | Fermented Containers (pail) | hard plastic, with 16 liter capacity, with cover | 5 | pc | 3 |
| 25 | Utility Tray | hard plastic tray, rectangular 14x18 inches | 20 | pc | 3 |
| 26 | Colander | medium, stainless steel, 8 quarts capacity, with base | 10 | pc | 3 |
| 27 | Smoke House | Width - 25" Height - 40" Length - 15", 3 Layers of Parliya inside, 1" for Tray above the Charcoal, 2" for the box of Charcoal, Gauge of Stainless - 1.0 Mirror | 1 | unit | 3 |
| 28 | Gas Stove with tank | 2 burner, made from stainless top body, automatic ignition, with complete accessories | 3 | unit | 3 |
| 29 | Polytemperature Sealer | 300mm long, 220 volts, 60 Hz, 400W | 2 | unit | 3 |
| 30 | Pressure Canner | 25 quarts, stainless steel | 2 | pc | 3 |
| 31 | Pressure Cooker | 8 quarts, stainless steel | 3 | pc | 3 |
| 32 | Electric Oven | 220 V, 60 Hz., 1000W, 18 L capacity, with warranty | 1 | unit | 3 |
| 33 | Meat Grinder | (size in cm) 49 x 23 x 29.5, stainless main materials, 220 volts, 60 Hz., 1/2 HP, with warranty | 1 | unit | 3 |
| 34 | Casseroles | stainless steel, 10" diameter, with lid | 4 | pc | 3 |
| 35 | Working Table | high quality stainless steel foldable tables dimension: 3ft x 3ft | 4 | pc | 3 |
| 36 | Chef Knife | 8 inch, stainless steel full tang blade with plastic handle | 10 | pc | 3 |
| 37 | Laptop | 15.6", Core i7, 1.40GHz, wide screen, 1TB hard drive, 8GB DDR3 memory, NVIDIA GTX 670MX graphic processor, 3GB video memory, Gigabit 10/100/1000Mbps IEEE802.11b/g/n Wireless LAN, web camera, HDMI, Bluetooth, USB2.0, USB3.0, with Windows 8 OS, up to 6 hours charge-in-use battery, DVDRW super Multi with 1 year warranty | 1 | unit | 3 |
| 38 | MS Office 2013 | Home & Student 1 user | 1 | unit | 3 |
| 39 | Projector | LCD Projector Portable, RGB liquid crystal shutter projection system (3LCD), White Light Output 2,600 lumens, Colour Light Output 2,600 lumens, XGA Resolution, lightweight: less than 2 kgs. | 1 | unit | 3 |
| 40 | HDMI cable | 3 meters, v1.4A HDMI cable for Projector | 1 | pc | 3 |
| 41 | Whiteboard | wooden whiteboard (2' x 3') with frame, 1 meter collapsible high stand | 1 | pc | 3 |
| 42 | PA System | 550W Portable with Trolley, with 2 wireless mics, 220V, RCA port, with warranty | 1 | unit | 3 |

1
N
96

Procurement of CMU Boxes, Tools and Equipment and Mock-ups for the Mobile Training Laboratories (MTLs).

**TESDA Camiguin Provincial Office
Mabini St. Poblacion Mambajao, Camiguin**

| NO. | ITEM | AGENCY SPECS | QTY | UNIT | No. Of Box |
|---|-------------------------------|--|-----|---------|------------|
| 43 | Megaphone | with speak and music switch and volume control, 25w | 1 | unit | 3 |
| 44 | First Aid Kit | First Aid Kit with the contents: betadine, alcohol, adhesive strips, band-aid, disposable gloves, hypoallergenic medical tape (1.25 cm x 9.1m), conforming bandage (5cm), triangular bandage (110m x 110cm), wound dressing no. 15, swab antiseptic, tweezers metal 8 cm, scissors disposable, safety pins assorted (12 pcs), hot and cold compress pack, first aid quick reference guide. | 1 | package | 3 |
| Plumbing NC II Tools and Equipment (for training purposes) | | | | | |
| 1 | Pipe Wrench | 12" straight, heavy duty, forged alloy steel 12", pipe capacity 2" or 50mm, weight 1.2 kg. cast-iron housing and I-beam handle with full floating forged hook jaw, featuring self cleaning threads with replaceable hook and heel jaws | 5 | pc | 3 |
| 2 | Pipe Wrench | 14" straight, heavy duty, forged alloy steel 12", pipe capacity 2" or 50mm, weight 1.6 kg. cast-iron housing and I-beam handle with full floating forged hook jaw, featuring self cleaning threads with replaceable hook and heel jaws | 5 | pc | 3 |
| 3 | Pull Push Rule | blade length 8 mtrs, blade width 1", high impact ABS case with durable rubber corrosion resistant Iru-zero end | 10 | pc | 3 |
| 4 | Hacksaw | adjustable hacksaw frame with bi-metal hacksaw blade, 24 TPI, aluminum alloy frame and handle | 5 | pc | 3 |
| 5 | Spirit Level | high impact plastic; magnetic; 3 vials; Length:24" | 5 | pc | 3 |
| 6 | Pipe Reamer | 2 " capacity, ratchet type with steel handle, 1/8-2 " capacity, suitable for use with power drives | 5 | pc | 3 |
| 7 | Pipe Cutter | max. capacity 1/8-2 " for steel or ductile iron pipes with steel handle | 5 | pc | 3 |
| 8 | Adjustable Wrench | alloy steel, 0 - 2 " jaw opening, 10" length | 5 | pc | 3 |
| 9 | Mechanical Plier | mechanical, plastic dipped insulated handle, 6 " length, rust-resistant chrome finish, two position adjustable joint pliers | 5 | pc | 3 |
| 10 | Pipe Vise | capacity 2", material steel, d with swivel base with dual locking nuts, 360 degrees of rotation. | 2 | pc | 3 |
| 11 | Pipe Threader | drop head with 3 sets of head and dies, sizes (1/2", 3/4", 1") | 2 | pc | 3 |
| 12 | Portable Tri-stand Chain Vise | 1/8 to 6 in., rear pipe support, rugged tool tray capacity: 1/8" - 6", leg locking: over center tool tray | 3 | pc | 3 |
| 13 | Manual Pressure Test Pump | 6 mpa, 860 psi max. pressure, 12 L. capacity, with brass pump valve | 1 | pc | 3 |
| 14 | Socket Fusion Machine | 20 mm - 32 mm cap, 3/4", 1", 1-1/4" and 1-1/2", 220V, 1600w | 2 | pc | 3 |
| 15 | Ballpeen hammer | 12 oz., 11 1/2" overall length forged steel construction, hardened and tempered, wooden handle | 5 | pc | 3 |
| 16 | Angle Grinder | 4 "diameter, wheel cap, 220V, 60 Hz, single phase, 11,000 rpm, all-ball bearing design and metal gear | 2 | pc | 3 |
| 17 | Electric Portable Drill | 1/2 " bit jaw capacity, 220V, single phase, variable speed (0-550 rpm), heavy duty, 1/2" drill chuck | 1 | pc | 3 |

7
2
9
10

Procurement of CMU Boxes, Tools and Equipment and Mock-ups for the Mobile Training Laboratories (MTLs).

**TESDA Camiguin Provincial Office
Mabini St. Poblacion Mambajao, Camiguin**

| NO. | ITEM | AGENCY SPECS | QTY | UNIT | No. Of Box |
|-----|---------------------------|--|-----|------|------------|
| 18 | Carpenter Steel Square | high tempered aluminum steel, 2" x 16" x 24", 5-60 and 30-degree angle markings, high tempered aluminum for maximum durability, 1/8-inch graduations for long-term visibility, body: 24 by 2-inches, tongue: 16 by 1-1/2" | 4 | pc | 3 |
| 19 | Claw Hammer | 16 oz., forged steel construction, hardened and tempered steel head, smooth face, wooden handle | 5 | pc | 3 |
| 20 | Paint Brush | 1/2" round trim brush soft bristle, tin-plated ferrules | 10 | pc | 3 |
| 21 | Hand Gloves | 5 finger, poly/cotton blend with a latex coated palm | 25 | pc | 3 |
| 22 | Safety Hard Hat | V-rib, yellow ball-cap style hard hat with 6 point ratchet-type headgear, 2 point chin strap and V rib on top, polyethylene material | 25 | pc | 3 |
| 23 | Safety Shoes | heavy duty steel toe cap, waterproof, anti static (sizes 40-42) Its anti-static and heat resistant (up to 300 degree C/572 degree F) with TPU SAFETY cell construction steel toe cap | 25 | pc | 3 |
| 24 | Safety Goggles | clear polycarbonate, woven elastic strap (adjustable) | 25 | pc | 3 |
| 25 | Water Meter | multi jet plastic meter, 1/2" NPT, 20 gpm, brass body | 1 | pc | 3 |
| 26 | Water Closet | flush type, ceramic, dimension (LxWxH): 684x430x787 mm, flushing action: siphonic, single/dual flush: single flush, flush Volume: 6L, flushing activation: front lever, rough-in: 305mm, discharge: floor cover | 1 | pc | 3 |
| 27 | Lavatory with Faucet | center hole, with mixing hot and cold faucet, ceramic, wall hung type, wall hung sink, 4-inch center faucet holes, front overflow, self-draining deck area with contoured back and side splash shields | 2 | pc | 3 |
| 28 | Kitchen Sink with Faucet | stainless steel, rust and heat resistant, grade 304, 74 cm x 51.5 cm, 16.2 mm outlet hole | 1 | pc | 3 |
| 29 | Single Point Water Heater | 4.5kw, 220V, 60 Hz, 2 psi min water pressure, 55 psi, 2 L/min minimum water flow, 1/2" BSP | 2 | pc | 3 |
| 30 | Laptop | 15.6", Core i7, 1.40GHz, wide screen, 1TB hard drive, 8GB DDR3 memory, NVIDIA GTX 670MX graphic processor, 3GB video memory, Gigabit 10/100/1000Mbps IEEE802.11b/g/n Wireless LAN, web camera, HDMI, Bluetooth, USB2.0, USB3.0, with Windows 8 OS, up to 6 hours charge-in-use battery, DVDRW super Multi with 1 year warranty | 1 | unit | 3 |
| 31 | MS Office 2013 | Home & Student 1 user | 1 | unit | 3 |
| 32 | Projector | LCD Projector Portable, RGB liquid crystal shutter projection system (3LCD), White Light Output 2,600 lumens, Colour Light Output 2,600 lumens, XGA Resolution, lightweight: less than 2 kgs. | 1 | unit | 3 |
| 33 | HDMI cable | 3 meters, v1.4A HDMI cable for Projector | 1 | pc | 3 |
| 34 | Whiteboard | wooden whiteboard (2' x 3') with frame, 1 meter collapsible high stand | 1 | pc | 3 |
| 35 | PA System | 550W Portable with Trolley, with 2 wireless mics, 220V, RCA port, with warranty | 1 | unit | 3 |
| 36 | Megaphone | with speak and music switch and volume control, 25w | 1 | unit | 3 |

*T
N
pd
atg*

Procurement of CMU Boxes, Tools and Equipment and Mock-ups for the Mobile Training Laboratories (MTLs).

**TESDA Camiguin Provincial Office
Mabini St. Poblacion Mambajao, Camiguin**

| NO. | ITEM | AGENCY SPECS | QTY | UNIT | No. Of Box |
|--|----------------------------|--|-----|---------|------------|
| 37 | First Aid Kit | First Aid Kit with the contents: betadine, alcohol, adhesive strips, band-aid, disposable gloves, hypoallergenic medical tape (1.25 cm x 9.1m), conforming bandage (5cm), triangular bandage (110m x 110cm), wound dressing no. 15, swab antiseptic, tweezers metal 8 cm, scissors disposable, safety pins assorted (12 pcs), hot and cold compress pack, first aid quick reference guide. | 1 | package | 3 |
| Small Engine Repair (Motorcycle/Small Engine Servicing NC II) Tools and Equipment (for training purposes) | | | | | |
| 1 | Impact Drive Tool | 4pcs, 1/2" Impact Driver Set, heavy duty. | 10 | set | 4 |
| 2 | Multi-Tester | analog, standard-size analog multimeter for measuring voltage, current, and resistance. An auxiliary connector is also provided for checking transistors. Specifications: •DC Voltage Range: 0 to 1000V in seven ranges •AC Voltage Range: 0 to 1000V in five ranges •DC Current Range: 0 to 250mA in four ranges •Resistance Range: x1 to 20KW in four ranges •Transistor hFE Range: -0 to 1000 •Transistors Leakage Current (ICEO) Range: -0 to 150mAAF Output Range: -10dB to +22dB | 10 | pc | 4 |
| 3 | Oiler | metal case, 1/2 liter cap | 10 | pc | 4 |
| 4 | Steel Brush | wooden handle | 10 | pc | 4 |
| 5 | Hacksaw | adjustable hacksaw frame with bi-metal hacksaw blade, 24 TPI, aluminum alloy frame and handle | 10 | pc | 4 |
| 6 | Center Punch | high speed steel, 5x125 mm | 10 | pc | 4 |
| 7 | Cold Chisel | flat blade, 1" (W), 6" (L), hardened steel | 10 | pc | 4 |
| 8 | Fly Wheel/Magneto Puller | universal type, six in one fly wheel/ magneto puller | 10 | pc | 4 |
| 9 | Oil Seal Remover/Installer | pointed tip, hardened steel w/ straight handle, 3 pcs per set | 10 | set | 4 |
| 10 | Piston Ring Compressor | self locking w/ L wrench steel, range 2 1/8" to 5 inch diameter | 10 | pc | 4 |
| 11 | Valve Spring Compressor | spring loaded offset jaw overhead valve spring compressor, steel | 10 | pc | 4 |
| 12 | Clutch Assembly Remover | universal compressor clutch hub for removal and installation | 10 | pc | 4 |
| 13 | Electricians Plier | overall length 6, knife length: 5/8", material: carbon steel handle finished: plastic dipped | 10 | pc | 4 |
| 14 | Diagonal Cutting Plier | dyna grip, 152mm/6" inches carbon steel | 10 | pc | 4 |

*T
N
pd
of*

Procurement of CMU Boxes, Tools and Equipment and Mock-ups for the Mobile Training Laboratories (MTLs).

**TESDA Camiguin Provincial Office
Mabini St. Poblacion Mambajao, Camiguin**

| NO. | ITEM | AGENCY SPECS | QTY | UNIT | No. Of Box |
|-----|----------------------|--|-----|------|------------|
| 15 | Mechanical Plier | 8", insulated handle | 10 | pc | 4 |
| 16 | Vise Gripped Plier | 10R straight jaw | 10 | pc | 4 |
| 17 | Feeler Gauge | 26 blade feeler gauge set, metric & English marked gauge | 10 | pc | 4 |
| 18 | Screwdriver, Flat | 8", magnetic tip, chrome vanadium, plastic handle | 10 | pc | 4 |
| 19 | Screwdriver, Philips | 8 ", magnetic tip, chrome vanadium, plastic handle | 10 | pc | 4 |
| 20 | Ballpeen hammer | 12 oz., 11 1/2" overall length forged steel construction, hardened and tempered, wooden handle | 10 | pc | 4 |
| 21 | Hammer, Brass/copper | 1 lb., wooden handle | 10 | pc | 4 |
| 22 | Hammer, Plastic | 1 lb, wooden handle, plastic tip hammer | 10 | pc | 4 |
| 23 | Wrench, Sparkplug | 19x16 mm, hexagonal w/ handle | 10 | pc | 4 |
| 24 | Wrench, Combination | 6mm,8mm,10mm,11mm,12mm,13mm,14mm,15mm,16mm,17mm,19mm, 21mm,22mm, 24 mm, chrome vanadium steel | 10 | set | 4 |
| 25 | Wrench, Socket | 8 - 32 mm., black, 1/2" drive | 10 | set | 4 |
| 26 | Wrench, T-type | 8, 10, 12, 14 mm | 10 | set | 4 |
| 27 | Hand Tractor Engine | diesel engine, single piston, 4 stroke direct injection, 10-12 hp | 2 | unit | 4 |
| 28 | Laptop | 15.6", Core i7, 1.40GHz, wide screen, 1TB hard drive, 8GB DDR3 memory, NVIDIA GTX 670MX graphic processor, 3GB video memory, Gigabit 10/100/1000Mbps IEEE802.11b/g/n Wireless LAN, web camera, HDMI, Bluetooth, USB2.0, USB3.0, with Windows 8 OS, up to 6 hours charge-in-use battery, DVDRW super Multi with 1 year warranty | 1 | unit | 4 |
| 29 | MS Office 2013 | Home & Student 1 user | 1 | unit | 4 |
| 30 | Projector | LCD Projector Portable, RGB liquid crystal shutter projection system (3LCD), White Light Output 2,600 lumens, Colour Light Output 2,600 lumens, XGA Resolution, lightweight: less than 2 kgs. | 1 | unit | 4 |
| 31 | HDMI cable | 3 meters, v1.4A HDMI cable for Projector | 1 | pc | 4 |

Handwritten initials and signature

Procurement of CMU Boxes, Tools and Equipment and Mock-ups for the Mobile Training Laboratories (MTLs).

**TESDA Camiguin Provincial Office
Mabini St. Poblacion Mambajao, Camiguin**

| NO. | ITEM | AGENCY SPECS | QTY | UNIT | No. Of Box |
|-----|---------------|--|-----|---------|------------|
| 32 | Whiteboard | wooden whiteboard (2' x 3') with frame, 1 meter collapsible high stand | 1 | pc | 4 |
| 33 | PA System | 550W Portable with Trolley, with 2 wireless mics, 220V, RCA port, with warranty | 1 | unit | 4 |
| 34 | Megaphone | with speak and music switch and volume control, 25w | 1 | unit | 4 |
| 35 | First Aid Kit | First Aid Kit with the contents: betadine, alcohol, adhesive strips, band-aid, disposable gloves, hypoallergenic medical tape (1.25 cm x 9.1m), conforming bandage (5cm), triangular bandage (110m x 110cm), wound dressing no. 15, swab antiseptic, tweezers metal 8 cm, scissors disposable, safety pins assorted (12 pcs), hot and cold compress pack, first aid quick reference guide. | 1 | package | 4 |

Handwritten signature/initials

**Procurement of CMU Boxes, Tools and Equipment and Mock-ups for
the Mobile Training Laboratories (MTLs).**

**TESDA Camiguin Provincial Office
Mabini St. Poblacion Mambajao, Camiguin**

| No. | Item / Description | Qty. | Unit | No. of Mock-up |
|--|--|------|------|----------------|
| Plumbing NC II Mock-up | | | | |
| 1 | Plumbing Mock-up (Labor Cost) | 1 | lot | 1 |
| SUPPLIES AND MATERIALS | | | | |
| 2 | 4" dia PVC Pipe (Orange) | 1 | pc | 1 |
| 3 | 4" dia. PVC Elbow 90 deg. | 1 | pc | 1 |
| 4 | 4" dia. PVC Elbow 45 deg. | 1 | pc | 1 |
| 5 | 4" dia. PVC Clean Out | 1 | pc | 1 |
| 6 | 4" x 3" PVC Wye | 1 | pc | 1 |
| 7 | 4" x 2" PVC Wye | 3 | pc | 1 |
| 8 | 3" dia. PVC pipe | 1 | pc | 1 |
| 9 | 3" PVC Elbow | 1 | pc | 1 |
| 10 | 3" PVC Elbow 45 deg. | 1 | pc | 1 |
| 11 | 3" x 2" PVC Tee | 1 | pc | 1 |
| 12 | 3" x 3" PVC Tee | 1 | pc | 1 |
| 13 | 2" dia PVC Pipe | 2 | pc | 1 |
| 14 | 2" dia. PVC Elbow 45 deg. | 3 | pc | 1 |
| 15 | 2" dia. PVC Elbow 90 deg. | 3 | pc | 1 |
| 16 | 2" PVC Tee | 4 | pc | 1 |
| 17 | 2" PVC P-trap | 2 | pc | 1 |
| 18 | 1/2" dia. PPr pipe | 2 | pc | 1 |
| 19 | 1/2" dia. PPr elbow | 7 | pc | 1 |
| 20 | 1/2" dia. PPr tee | 4 | pc | 1 |
| 21 | 1/2" dia. PPr elbow connector | 6 | pc | 1 |
| 22 | 1/2" dia. PPr male connector | 2 | pc | 1 |
| 23 | 1/2" dia. PPr union | 3 | pc | 1 |
| 24 | 1/2" dia. PPr coupling | 4 | pc | 1 |
| 25 | Urinal 480mm X 730mm X 730mm with complete accessories | 1 | unit | 1 |
| 26 | Shower head with complete accessories | 1 | unit | 1 |
| 27 | 1/2 x 7/8 flexible hose | 1 | pc | 1 |
| 28 | 1/2 x 1/2" angle valve | 3 | pc | 1 |
| 29 | 3/4" x 4' x 8' Marine Plywood | 1 | pc | 1 |
| 30 | 2" x 2" x 12' Lumber | 4 | pc | 1 |
| 31 | Teflon Tape | 10 | pc | 1 |
| 32 | Metal hinges 2" X 4", heavy duty | 3 | pc | 1 |
| This include supplies and materials required in the fabrication of mock-up | | | | |
| Small Engine Repair (Motorcycle/Small Engine Servicing NC II) Tools and Equipment Mock-up | | | | |
| 1 | Motorcycle/Small Engine Collapsible Mock-Up | 1 | lot | 1 |
| SUPPLIES AND MATERIALS: | | | | |
| 2 | Auto wire, stranded # 16 | 1 | roll | 1 |
| 3 | Electrical tape, large black | 2 | pc | 1 |
| 4 | Head light assembly, 12 volts rectangular | 1 | pc | 1 |
| 5 | signal light assembly, 12 volts | 2 | pair | 1 |
| 6 | Horn, 12 volts | 1 | pc | 1 |
| 7 | Stop light switch, push button | 1 | pc | 1 |
| 8 | Signal light switch, double throw, toggle switch | 1 | pc | 1 |
| 9 | Ignition switch, gas engine type | 1 | pc | 1 |
| 10 | Signal light relay, 12 volts | 1 | pc | 1 |
| 11 | Push button switch for horn | 1 | pc | 1 |

TN
afg pb

**Procurement of CMU Boxes, Tools and Equipment and Mock-ups for
the Mobile Training Laboratories (MTLs).**

**TESDA Camiguin Provincial Office
Mabini St. Poblacion Mambajao, Camiguin**

| No. | Item / Description | Qty. | Unit | No. of Mock-up |
|--|---|------|-------|----------------|
| 12 | Motorcycle storage battery, 12 volts maintenance free | 1 | pc | 1 |
| 13 | Harness cover, 3/8" diameter (140/4) | 4 | meter | 1 |
| 14 | Harness connector, 6 terminals | 4 | pc | 1 |
| 15 | Male terminal, flat | 30 | pc | 1 |
| 16 | Female terminal, flat | 30 | pc | 1 |
| 17 | Headlight switch or toggle switch, single throw | 1 | pc | 1 |
| 18 | Crocodile clip, medium, red and black | 1 | pair | 1 |
| 19 | 3/16" diameter X 3/4" stove bolt, stainless | 20 | pc | 1 |
| 20 | 3/16" diameter hole, eye terminal | 10 | pc | 1 |
| | | | | |
| 21 | Four stroke motorcycle engine, 125 or 155cc, surplus | 1 | unit | 1 |
| This include supplies and materials required in the fabrication of mock-up | | | | |

1
W
96

Procurement of CMU Boxes, Tools and Equipment and Mock-ups for the Mobile Training Laboratories (MTLs).

**TESDA North Cotabato Provincial Office
Capitol Hi-way, Amas, Kidapawan City**

| NO. | ITEM | AGENCY SPECS | QTY | UNIT | No. Of Box |
|---|--|---|-----|------|------------|
| Appliance Repair NC II Tools and Equipment (for training purposes) | | | | | |
| 1 | Soldering Iron | dual wattage, 25 watts/ 120watts, 220 volt 60 Hz, with long life tip, "gun type" | 25 | unit | 3 |
| 2 | Desoldering Tools | desoldering pump with precision regulated return, replacement tip compact, metal housing | 25 | unit | 3 |
| 3 | Screw driver assorted (Phillips and slotted) | 12x7x1 inches, 6 pieces per set, plastic handle | 5 | set | 3 |
| 4 | Long Nose Plier | dyna grip, 152mm/6" inches carbon steel | 5 | pc | 3 |
| 5 | Diagonal Cutting Plier | dyna grip, 152mm/6" inches carbon steel | 5 | pc | 3 |
| 6 | Nut Drivers | rust-resistant, nickel-plated bar, hexagonal shank, includes: 5mm, 6mm, 7mm, 8mm, 9mm, 10mm, 11mm | 5 | set | 3 |
| 7 | Wrench, Combination | 6mm,8mm,10mm,11mm,12mm,13mm,14mm,15mm, 16mm,17mm,19mm, 21mm,22mm, 24 mm, chrome vanadium steel | 5 | set | 3 |
| 8 | Wire Stripper | automatic, cap. 1.5mm to 3.5mm | 10 | pc | 3 |
| 9 | Ballpeen hammer | 12 oz.,11 1/2" overall length forged steel construction, hardened and tempered, wooden handle | 5 | pc | 3 |
| 10 | Flashlight | LED, 3 volts/6 volts, rechargeable | 5 | pc | 3 |
| 11 | Detector Light | test light, 220 volts | 5 | pc | 3 |
| 12 | Paint Brush | 4 inches width, wooden handle | 25 | pc | 3 |
| 13 | Microwave Oven | power capacity: 220V 1300 watts, interior capacity 20 liters, 8 programmes, defrost option, 26cm diameter rotating turntable, digital | 1 | unit | 3 |
| 14 | Washing Machine with dryer | power capacity: 500w, 220V, rust proof body, gear drive system, dolphin drive pulsator, washing capacity (dry weight) 7.5kg, spinning capacity (dry weight) 5.5kg, width should be more than 50 cm and length of not more than 100 cm | 1 | unit | 3 |
| 15 | Electric Fan | power capacity: 220V, 100w, 60Hz, 3 speed rotary switch, 18 inch metal blade, round/stable plastic base, thermal fuse protection, adjustable height stand fan | 1 | unit | 3 |
| 16 | Electric Rice Cooker | power capacity: 700w, 220V, 60Hz, automatic cooking feature, auto shutoff, glass lid, non-stick coated aluminum pan, includes measuring cup and rice scoop | 1 | unit | 3 |

TNH
att

Procurement of CMU Boxes, Tools and Equipment and Mock-ups for the Mobile Training Laboratories (MTLs).

**TESDA North Cotabato Provincial Office
Capitol Hi-way, Amas, Kidapawan City**

| NO. | ITEM | AGENCY SPECS | QTY | UNIT | No. Of Box |
|-----|--------------------|---|-----|------|------------|
| 17 | Electric Flat Iron | power capacity:1000w, 220V, 60 Hz, non-stick Teflon soleplate, thermal fuse protected, variable temperature control, automatic thermostat Control, pilot lamp indicator | 1 | unit | 3 |
| 18 | Coffee Maker | power capacity: 550w, 220V, 60Hz, glass pitcher, anti-drip feature, 6 cup water capacity, water level indicator, swing-out filter basket | 1 | unit | 3 |
| 19 | Oven Toaster | power capacity: 1000w, 220V, 60Hz, stainless steel, 8 liter capacity, 15 minute timer, slide out chrome crumb rack, includes baking tray | 1 | unit | 3 |
| 20 | Blender | 1.5 liter capacity, rated voltage, 230V, 60Hz, power consumption: 300 watts, sharp stainless steel blade, safety lock switch, with plastic stirrer for easy mixing | 1 | unit | 3 |
| 21 | Multi Tester | analog, standard size analog multimeter for measuring voltage, current and resistance. An auxiliary connector is also provided for checking transistors. SPECIFICATION: •DC Voltage Range: 0 to 1000V in seven ranges •AC Voltage Range: 0 to 1000V in five ranges •DC Current Range: 0 to 250mA in four ranges •Resistance Range: x1 to 200MEG in four ranges •Transistor hFE Range: -0 to 1000 •Transistors Leakage Current (ICEO) Range: -0 to 150mAAF Output Range: -10dB to +22dB | 25 | unit | 3 |
| 22 | Multi Tester | Digital Multi meters are standard digital multimeter for measuring voltage, current, and resistance with 3-1/2 digit LCD display. This meter measures only 138mm x 70mm x 32mm and weighs approximately 140 grams, including battery. SPECIFICATION: •DC Voltage Range: 200mV to 600V in five ranges (auto ranging) •AC Voltage Range: 2V to 600V in four ranges (auto ranging) •DC Current Range: 200mA to 10A in six ranges •Resistance Range: 200 Ohms to 20M in six ranges Transistor hFE Test Range: 0 to 2000 | 25 | unit | 3 |
| 23 | Laptop | 15.6", Core i7, 1.40GHz, wide screen, 1TB hard drive, 8GB DDR3 memory, NVIDIA GTX 670MX graphic processor, 3GB video memory, Gigabit 10/100/1000Mbps IEEE802.11b/g/n Wireless LAN, web camera, HDMI, Bluetooth, USB2.0, USB3.0, with Windows 8 OS, up to 6 hours charge-in-use battery, DVDRW super Multi with 1 year warranty | 1 | unit | 3 |

TN
af

Procurement of CMU Boxes, Tools and Equipment and Mock-ups for the Mobile Training Laboratories (MTLs).

**TESDA North Cotabato Provincial Office
Capitol Hi-way, Amas, Kidapawan City**

| NO. | ITEM | AGENCY SPECS | QTY | UNIT | No. Of Box |
|--|------------------|--|-----|---------|------------|
| 24 | MS Office 2013 | Home & Student 1 user | 1 | unit | 3 |
| 25 | Projector | LCD Projector Portable, RGB liquid crystal shutter projection system (3LCD), White Light Output 2,600 lumens, Colour Light Output 2,600 lumens, XGA Resolution, lightweight: less than 2 kgs. | 1 | unit | 3 |
| 26 | HDMI cable | 3 meters, v1.4A HDMI cable for Projector | 1 | pc | 3 |
| 27 | Whiteboard | wooden whiteboard (2' x 3') with frame, 1 meter collapsible high stand | 1 | pc | 3 |
| 28 | PA System | 550W Portable with Trolley, with 2 wireless mics, 220V, RCA port, with warranty | 1 | unit | 3 |
| 29 | Megaphone | with speak and music switch and volume control, 25w | 1 | unit | 3 |
| 30 | First Aid Kit | First Aid Kit with the contents: betadine, alcohol, adhesive strips, band-aid, disposable gloves, hypoallergenic medical tape (1.25 cm x 9.1m), conforming bandage (5cm), triangular bandage (110m x 110cm), wound dressing no. 15, swab antiseptic, tweezers metal 8 cm, scissors disposable, safety pins assorted (12 pcs), hot and cold compress pack, first aid quick reference guide. | 1 | package | 3 |
| Cookery NC II Tools and Equipment (for training purposes) | | | | | |
| 1 | Chef Knife | 8 inch, stainless steel full tang blade with plastic handle | 10 | pc | 3 |
| 2 | Boning Knife | 6 inches, stainless steel with sharp cutting edge with plastic handle | 8 | pc | 3 |
| 3 | Oyster Knife | 7 inches length (3 inches blade and 4 inches handle), stainless steel blade, with comfortable plastic handle | 4 | pc | 3 |
| 4 | Cleaver Knife | 7 inches, stain resistant carbon steel blade | 2 | pc | 3 |
| 5 | Tenderizer | with flat and textured side, non slip, 10 inches 25.5 cm, solid aluminum construction | 8 | pc | 3 |
| 6 | Skimmer | fine, extra fine mesh, 6 inches diameter, with stainless handle | 8 | pc | 3 |
| 7 | Wire Skimmer | small, nickel plated wire oil skimmer, 16 inches long overall, 5 inches diameter bowl | 8 | pc | 3 |
| 8 | Skimmer | spider, 5 inches diameter, natural bamboo handle, constructed of durable stainless steel with versatile woven design | 8 | pc | 3 |
| 9 | Strainer, small | fine, 6" diameter, with stainless handle | 8 | pc | 3 |
| 10 | Siever | small 12" diameter, stainless | 8 | pc | 3 |
| 11 | Strainer, medium | medium, fine stainless steel mesh, 9 inches diameter with stainless handle | 8 | pc | 3 |

TN
91
05

Procurement of CMU Boxes, Tools and Equipment and Mock-ups for the Mobile Training Laboratories (MTLs).

**TESDA North Cotabato Provincial Office
Capitol Hi-way, Amas, Kidapawan City**

| NO. | ITEM | AGENCY SPECS | QTY | UNIT | No. Of Box |
|-----|--------------------------|--|-----|------|------------|
| 12 | Turner | solid, stainless steel, with handy loop for hanging, 12 inches long | 8 | pc | 3 |
| 13 | Spatula | Stainless steel straight blade, 14 inches long with wood handle | 8 | pc | 3 |
| 14 | Wooden Spatula | large comfortable handle, 12 inches long, wooden | 8 | pc | 3 |
| 15 | Piping Bag | 12 inches, light weight, reusable, flexible polyester, coated, can be boiled, dishwasher safe | 8 | pc | 3 |
| 16 | Pastry Tubes | steel stainless, set of 24 pcs, different/assorted icing nozzles medium size, constructed of 18/8 quality stainless steel, comes in plastic storage box with lid | 8 | set | 3 |
| 17 | Strainer, chinois medium | medium, 8 inches diameter, stainless steel including handle | 3 | pc | 3 |
| 18 | Strainer, chinois small | small, 5 inches diameter, stainless steel including handle | 2 | pc | 3 |
| 19 | Funnel | general purpose, hard plastic, comes in 4 different sizes (small, medium, large, extra large) | 4 | set | 3 |
| 20 | Measuring Spoon | Stainless steel 6 pcs/set (1/8 tsp, 1/4 tsp, 1/2 tsp, 1 tsp, 1/2 tbsp, 1 tbsp) | 6 | set | 3 |
| 21 | Food Tong | 12 inches long, stainless steel, and wide shell head with locking | 8 | pc | 3 |
| 22 | Measuring Cup, liquid | glass graduated, 250 ml capacity | 8 | pc | 3 |
| 23 | Ice Cream Scooper | set of three, stainless steel (2 oz, 4 oz and 6 oz) | 2 | set | 3 |
| 24 | Cheese Cloth | 100% cotton 1 yard | 10 | pc | 3 |
| 25 | Serving Spoon | stainless steel, 9 inches long | 24 | pc | 3 |
| 26 | Pepper and Salt Mill | 2 in 1, wooden, 8" | 4 | pc | 3 |
| 27 | Weighing Scale | analog weighing scale; maximum weight capacity, 5 kg, graduated by grams, removable and washable tray | 2 | unit | 3 |
| 28 | Weighing Scale | digital, 1000g, maximum weight capacity, battery operated (AAA battery) 0.1 g to 1000g, LCD display battery included. | 2 | unit | 3 |
| 29 | Apple Corer | corer head comfortable on slip handle, corer head is stainless steel | 4 | pc | 3 |
| 30 | Wire Whisk | 8"/20cm, aluminum, balloon style | 8 | pc | 3 |
| 31 | Wire Whisk, medium | medium, 10 inches/25 cm, aluminum, balloon style | 8 | pc | 3 |
| 32 | Wire Whisk, large | heavy duty, stainless steel, 14 inches, balloon style | 2 | pc | 3 |
| 33 | Measuring Cup, dry | stainless steel, 4 pcs/set (1c, 1/2c, 1/3c & 1/4c) | 1 | set | 3 |
| 34 | Chopping Board | 12 x17 Inches, polyethylene, easy grip handle, white color | 10 | pc | 3 |

TN
gd
AK

Procurement of CMU Boxes, Tools and Equipment and Mock-ups for the Mobile Training Laboratories (MTLs).

**TESDA North Cotabato Provincial Office
Capitol Hi-way, Amas, Kidapawan City**

| NO. | ITEM | AGENCY SPECS | QTY | UNIT | No. Of Box |
|-----|------------------------|---|-----|------|------------|
| 35 | Kitchen Scissors | stainless steel blade, size 2 cm x 12 cm x 27 cm, durable and sturdy handle with comfortable grip | 8 | pc | 3 |
| 36 | Soup Ladle | 3 oz capacity, stainless steel, with handle, round bottom | 8 | pc | 3 |
| 37 | Soup Ladle | 6 oz capacity, stainless steel handle, round bottom | 8 | pc | 3 |
| 38 | Soup Ladle | 8 oz capacity, stainless steel handle, round bottom | 3 | pc | 3 |
| 39 | Soup Ladle | 12 oz capacity, stainless handle, round bottom, | 2 | pc | 3 |
| 40 | Mixing Bowl | 12 inches diameter, 8-9 quarts capacity, stainless | 10 | pc | 3 |
| 41 | Kitchen Spoon | solid, stainless steel handle, comfortable non slip handle, round handle 4.5 x 2.5 inches | 8 | pc | 3 |
| 42 | Kitchen Spoon | slotted, stainless steel, comfortable non slip handle, round handle 10 x 2.5 inches w/ hole | 8 | pc | 3 |
| 43 | Kitchen Fork | 7.5 cm x 4.5 cm x 37 cm or 10.5 inches, stainless steel, with 2 prongs, round handle | 8 | pc | 3 |
| 44 | Carving Fork | 10.5 inches, stainless steel, with 2 prongs, round handle | 3 | pc | 3 |
| 45 | Pocket Pin Thermometer | analog, temperature range from 0oF to 220 of, dial type | 3 | pc | 3 |
| 46 | Peeler | Straight blade type, dual stainless steel blade, metal handle 5", 2" handle, 3" blade | 8 | pc | 3 |
| 47 | Stockpot | stainless, 17 quarts capacity (22.7 lit), 12 inches diameter (30.5 cm), depth 31 cm, 4 mm thickness | 2 | pc | 3 |
| 48 | Frying pan | pan, large, non stick, 26 cm diameter | 2 | pc | 3 |
| 49 | Colander | medium, stainless steel, 8 quarts capacity, with base | 2 | pc | 3 |
| 50 | Fish Poacher | medium, 18 inches (L) and 6 inches (w), stainless steel, with handle | 1 | pc | 3 |
| 51 | Casserole | small, stainless steel, 20 cm diameter, with cover | 8 | pc | 3 |
| 52 | Casserole | medium, stainless steel, 24 cm diameter with cover | 4 | pc | 3 |
| 53 | Double Boiler | medium, made from stainless steel, 2 quarts capacity, with lid cover | 1 | pc | 3 |
| 54 | Paellara | 40 cm diameter, (50 cm with handle), constructed of carbon steel, riveted secure melt handle, safe for all heating surfaces including induction | 4 | pc | 3 |
| 55 | Baking Tray | small, main material is carbon, rectangular, size 14 x 10 inches | 8 | pc | 3 |
| 56 | Utility Tray | hard plastic tray, rectangular 14x18 inches | 12 | pc | 3 |

Y
N
pl
ab

Procurement of CMU Boxes, Tools and Equipment and Mock-ups for the Mobile Training Laboratories (MTLs).

**TESDA North Cotabato Provincial Office
Capitol HI-way, Amas, Kidapawan City**

| NO. | ITEM | AGENCY SPECS | QTY | UNIT | No. Of Box |
|-----|---------------------|--|-----|------|------------|
| 57 | Fire Extinguisher | cylinder type, multipurpose ABC dry chemical, powder aluminum valve coated, rechargeable, 5 lbs capacity, with pressure gauge that allows for immediate pressure status check, with wall hanger, meets requirements for underwriter laboratory (UJ) | 1 | unit | 3 |
| 58 | Blender | 1.5 liter capacity, rated voltage, 230V, 60Hz, power consumption: 300 watts, sharp stainless steel blade, safety lock switch, with plastic stirrer for easy mixing | 1 | unit | 3 |
| 59 | Pressure Cooker | aluminum, 2 mm, 6 quarts capacity, pressured handle, central pressure valve with self locking mechanism | 1 | pc | 3 |
| 60 | Gas Stove with tank | 2 burner, made from stainless top body, automatic ignition, with complete accessories | 4 | unit | 3 |
| 61 | Working Table | high quality stainless steel foldable tables dimension: 3ft x 3ft | 4 | pc | 3 |
| 62 | Kitchen Sink | Kitchen sink, portable single bowl sink stainless steel, with steel collapsible frame legs, with drain hose, Dimension 50cmx50cmx30cm | 1 | unit | 3 |
| 63 | Laptop | 15.6", Core i7, 1.40GHz, wide screen, 1TB hard drive, 8GB DDR3 memory, NVIDIA GTX 870MX graphic processor, 3GB video memory, Gigabit 10/100/1000Mbps IEEE802.11b/g/n Wireless LAN, web camera, HDMI, Bluetooth, USB2.0, USB3.0, with Windows 8 OS, up to 6 hours charge-in-use battery, DVDRW super Multi with 1 year warranty | 1 | unit | 3 |
| 64 | MS Office 2013 | Home & Student 1 user | 1 | unit | 3 |
| 65 | Projector | LCD Projector Portable, RGB liquid crystal shutter projection system (3LCD), White Light Output 2,600 lumens, Colour Light Output 2,600 lumens, XGA Resolution, lightweight: less than 2 kgs. | 1 | unit | 3 |
| 66 | HDMI cable | 3 meters, v1.4A HDMI cable for Projector | 1 | pc | 3 |
| 67 | Whiteboard | wooden whiteboard (2' x 3') with frame, 1 meter collapsible high stand | 1 | pc | 3 |
| 68 | PA System | 550W Portable with Trolley, with 2 wireless mics, 220V, RCA port, with warranty | 1 | unit | 3 |
| 69 | Megaphone | with speak and music switch and volume control, 25w | 1 | unit | 3 |

Handwritten marks: a large number '7', a checkmark, and some illegible scribbles.

Procurement of CMU Boxes, Tools and Equipment and Mock-ups for the Mobile Training Laboratories (MTLs).

**TESDA North Cotabato Provincial Office
Capitol Hi-way, Amas, Kidapawan City**

| NO. | ITEM | AGENCY SPECS | QTY | UNIT | No. Of Box |
|--|-----------------------|--|-----|---------|------------|
| 70 | First Aid Kit | First Aid Kit with the contents: betadine, alcohol, adhesive strips, band-aid, disposable gloves, hypoallergenic medical tape (1.25 cm x 9.1m), conforming bandage (5cm), triangular bandage (110m x 110cm), wound dressing no. 15, swab antiseptic, tweezers metal 8 cm, scissors disposable, safety pins assorted (12 pcs), hot and cold compress pack, first aid quick reference guide. | 1 | package | 3 |
| Electrical Installation and Maintenance NC II Tools and Equipment (for training purposes) | | | | | |
| 1 | Spirit Level | high impact plastic; magnetic; 3 vials; Length:24" | 1 | pc | 2 |
| 2 | Hacksaw | adjustable hacksaw frame with bi-metal hacksaw blade, 24 TPI, aluminum alloy frame and handle | 5 | pc | 2 |
| 3 | Pipe Cutter | max. capacity 1/8-2 " for steel or ductile iron pipes with steel handle | 2 | pc | 2 |
| 4 | Pipe Reamer | 2 " capacity, ratchet type with steel handle, 1/8-2 " capacity, suitable for use with power drives | 2 | pc | 2 |
| 5 | Pipe Threader | drop head with 3 sets of head and dies, sizes (1/2", 3/4", 1") | 2 | unit | 2 |
| 6 | Pipe Bender | manual, 1/2-3/4 inch bending radius, ductile high strength iron | 2 | unit | 2 |
| 7 | Electricians Plier | overall length 6, knife length: 5/8", material: carbon steel handle finished: plastic dipped | 25 | pc | 2 |
| 8 | Long Nose Plier | dyna grip, 152mm/6" inches carbon steel | 25 | pc | 2 |
| 9 | Phillips Screw Driver | 1x75, PH 2 x 100, PH 2x125 plastic and rubberized handle chrome vanadium, shank 4" | 25 | set | 2 |
| 10 | Flat Screw Driver | 3x75, 5x100, 6x125 plastic and rubberized handle chrome vanadium shank 4" | 25 | set | 2 |
| 11 | Wrench, Combination | 6mm,8mm,10mm,11mm,12mm,13mm,14mm,15mm, 16mm,17mm,19mm, 21mm,22mm, 24 mm, chrome vanadium steel | 5 | set | 2 |
| 12 | Wire Stripper | automatic, cap. 1.5mm to 3.5mm | 10 | pc | 2 |
| 13 | Electrician Knife | blade length 3", taper ground cutlery single steel blade, ergonomically designed slip resistant grip | 25 | pc | 2 |
| 14 | Tool Holster | leather, 3 pocket & 4 holes with belt | 25 | pc | 2 |
| 15 | Pull Push Rule | blade length 8 mtrs, blade width 1", high impact ABS case with durable rubber corrosion resistant tru-zero end | 25 | pc | 2 |
| 16 | Claw Hammer | 16 oz., forged steel construction, hardened and tempered steel head, smooth face, wooden handle | 10 | pc | 2 |
| 17 | Heat Gun | 1600 watts, 230v,60 Hz, 12.5 amp. dual temperature, with different nozzle | 2 | unit | 2 |
| 18 | Power Drill | drilling cap.:10mm, cap. wood: 20mm, wattage 350w, no load speed: 0-2500rpm, weight 1.1 kg., Rev.- for rotation, 3/8" capacity. 220VAC, 60Hz | 2 | unit | 2 |

7
N
H
ABR

Procurement of CMU Boxes, Tools and Equipment and Mock-ups for the Mobile Training Laboratories (MTLs).

**TESDA North Cotabato Provincial Office
Capitol Hi-way, Amas, Kidapawan City**

| NO. | ITEM | AGENCY SPECS | QTY | UNIT | No. Of Box |
|--|----------------|--|-----|---------|------------|
| 19 | Multi-Tester | analog, standard-size analog multimeter for measuring voltage, current, and resistance. An auxiliary connector is also provided for checking transistors. Specifications: •DC Voltage Range: 0 to 1000V in seven ranges •AC Voltage Range: 0 to 1000V in five ranges •DC Current Range: 0 to 250mA in four ranges •Resistance Range: x1 to 20KW in four ranges •Transistor hFE Range: -0 to 1000 •Transistors Leakage Current (ICEO) Range: -0 to 150mAAF Output Range: -10dB to +22dB | 5 | unit | 2 |
| 20 | Clamp Ammeter | digital max. AC voltage measurement 600V, max. AC current measurement 400Aac, max. DC voltage measurement 600Vdc, max. resistance measurement 400ohms, battery type AAA, clamp meter type, continuity current, frequency, resistance, voltage, display type LCD, jaw capacity, bus bars 10x34mm, safety category voltage, 300V, 600V | 2 | unit | 2 |
| 21 | Pipe Vise | capacity 2", material steel, d with swivel base with dual locking nuts, 360 degrees of rotation. | 2 | pc | 2 |
| 22 | Laptop | 15.6", Core i7, 1.40GHz, wide screen, 1TB hard drive, 8GB DDR3 memory, NVIDIA GTX 670MX graphic processor, 3GB video memory, Gigabit 10/100/1000Mbps IEEE802.11b/g/n Wireless LAN, web camera, HDMI, Bluetooth, USB2.0, USB3.0, with Windows 8 OS, up to 6 hours charge-in-use battery, DVDRW super Multi with 1 year warranty | 1 | unit | 2 |
| 23 | MS Office 2013 | Home & Student 1 user | 1 | unit | 2 |
| 24 | Projector | LCD Projector Portable, RGB liquid crystal shutter projection system (3LCD), White Light Output 2,600 lumens, Colour Light Output 2,600 lumens, XGA Resolution, lightweight: less than 2 kgs. | 1 | unit | 2 |
| 25 | HDMI cable | 3 meters, v1.4A HDMI cable for Projector | 1 | pc | 2 |
| 26 | Whiteboard | wooden whiteboard (2' x 3') with frame, 1 meter collapsible high stand | 1 | pc | 2 |
| 27 | PA System | 550W Portable with Trolley, with 2 wireless mics, 220V, RCA port, with warranty | 1 | unit | 2 |
| 28 | Megaphone | with speak and music switch and volume control, 25w | 1 | unit | 2 |
| 29 | First Aid Kit | First Aid Kit with the contents: betadine, alcohol, adhesive strips, band-aid, disposable gloves, hypoallergenic medical tape (1.25 cm x 9.1m), conforming bandage (5cm), triangular bandage (110m x 110cm), wound dressing no. 15, swab antiseptic, tweezers metal 8 cm, scissors disposable, safety pins assorted (12 pcs), hot and cold compress pack, first aid quick reference guide. | 1 | package | 2 |
| Food Processing NC II Tools and Equipment (for training purposes) | | | | | |
| 1 | Weighing Scale | Manual weighing scale; maximum weight capacity, 5 kg., graduated by grams, removable and washable tray | 5 | unit | 3 |
| 2 | Weighing Scale | digital, 1000g, maximum weight capacity, battery operated (AAA battery) 0.1 g to 1000g, LCD display battery included. | 5 | unit | 3 |
| 3 | Paring Knives | stainless steel blade, 4 inches | 25 | pc | 3 |

TN
pb
ab

Procurement of CMU Boxes, Tools and Equipment and Mock-ups for the Mobile Training Laboratories (MTLs).

**TESDA North Cotabato Provincial Office
Capitol Hi-way, Amas, Kidapawan City**

| NO. | ITEM | AGENCY SPECS | QTY | UNIT | No. Of Box |
|-----|-----------------------------|--|-----|------|------------|
| 4 | Peeler | Straight blade type, dual stainless steel blade, metal handle 5", 2" handle, 3" blade | 12 | pc | 3 |
| 5 | Measuring Spoon | Stainless steel 6 pcs/set (1/8 tsp, 1/4 tsp, 1/2 tsp, 1 tsp, 1/2 tbsp, 1 tbsp) | 6 | set | 3 |
| 6 | Measuring Cup, dry | stainless steel, 4 pcs/set (1c, 1/2c, 1/3c & 1/4c) | 6 | set | 3 |
| 7 | Measuring Cup, liquid | glass graduated, 250 ml capacity | 6 | pc | 3 |
| 8 | Clocks/Timer | digital, battery operated, with convenient clip, battery included. | 5 | pc | 3 |
| 9 | Mixing Bowl | 12 inches diameter, 8-9 quarts capacity, stainless | 12 | set | 3 |
| 10 | Chopping Board | 12x17 inches, polyethylene, easy grip handle, white color | 3 | set | 3 |
| 11 | Dial Thermometer | stainless steel, 12" stem, stainless clip | 5 | pc | 3 |
| 12 | Osterizers | 8 speed with pulse, 500 watts, 220 volts 60 hertz, stainless steel ice crusher blade, 6 cups glass jar capacity, with warranty. | 4 | unit | 3 |
| 13 | Jar Lifter | non slip handle, rubberized 5" full expansion | 5 | pc | 3 |
| 14 | Food Processors | with exact slice system, 2 in one wide mouth feed tube, with high, low, pulse, off operation, adjustable stainless steel slicing disc and ultra tight seal, 220 volts, 60 hertz, 700 watts | 1 | unit | 3 |
| 15 | Wire Baskets | stainless steel, rectangular, with handle, 4" x 17.75" x 14" (HxWxD) | 5 | pc | 3 |
| 16 | Casseroles | stainless steel, with cover, 5 quarts capacity, with long handles | 5 | pc | 3 |
| 17 | Saucepan | stainless steel, with cover and handle, 26 cm | 5 | pc | 3 |
| 18 | Spoon, wooden | wooden turner, size 12 inches | 15 | pc | 3 |
| 19 | Spoon, basting | 12" long, 100% solid wood, strong and durable. | 15 | pc | 3 |
| 20 | Paddle, wooden | solid wood, 24 inches length x 3-1/2 inches width | 4 | pc | 3 |
| 21 | Food Tong | 12 inches long, stainless steel, and wide shell head with locking | 14 | pc | 3 |
| 22 | Kitchen Scissors | stainless steel blade, size 2 cm x 12 cm x 27 cm, durable and sturdy handle with comfortable grip | 12 | pc | 3 |
| 23 | Steamer | 6 quarts base pan doubles as a stock pot, aluminum, with cover, 3 layer, 30 cm | 4 | pc | 3 |
| 24 | Fermented Containers (pail) | hard plastic, with 16 liter capacity, with cover | 5 | pc | 3 |
| 25 | Utility Tray | hard plastic tray, rectangular 14x18 inches | 20 | pc | 3 |
| 26 | Colander | medium, stainless steel, 8 quarts capacity, with base | 10 | pc | 3 |
| 27 | Smoke House | Width - 25" Height - 40" Length - 15", 3 Layers of Pariya inside, 1" for Tray above the Charcoal, 2" for the box of Charcoal, Gauge of Stainless - 1.0 Mirror | 1 | unit | 3 |
| 28 | Gas Stove with tank | 2 burner, made from stainless top body, automatic ignition, with complete accessories | 3 | unit | 3 |
| 29 | Polytemperature Sealer | 300mm long, 220 volts, 60 Hz, 400W | 2 | unit | 3 |
| 30 | Pressure Canner | 25 quarts, stainless steel | 2 | pc | 3 |
| 31 | Pressure Cooker | 8 quarts, stainless steel | 3 | pc | 3 |
| 32 | Electric Oven | 220 V, 60 Hz., 1000W, 18 L capacity, with warranty | 1 | unit | 3 |
| 33 | Meat Grinder | (size in cm) 49 x 23 x 29.5, stainless main materials, 220 volts, 60 Hz., 1/2 HP, with warranty | 1 | unit | 3 |
| 34 | Casseroles | stainless steel, 10" diameter, with lid | 4 | pc | 3 |
| 35 | Working Table | high quality stainless steel foldable tables dimension: 3ft x 3ft | 4 | pc | 3 |

Handwritten signature and initials in the bottom right corner.

Procurement of CMU Boxes, Tools and Equipment and Mock-ups for the Mobile Training Laboratories (MTLs).

**TESDA North Cotabato Provincial Office
Capitol Hi-way, Amas, Kidapawan City**

| NO. | ITEM | AGENCY SPECS | QTY | UNIT | No. Of Box |
|---|-------------------|--|-----|---------|------------|
| 36 | Chef Knife | 8 inch, stainless steel full tang blade with plastic handle | 10 | pc | 3 |
| 37 | Laptop | 15.6", Core i7, 1.40GHz, wide screen, 1TB hard drive, 8GB DDR3 memory, NVIDIA GTX 670MX graphic processor, 3GB video memory, Gigabit 10/100/1000Mbps IEEE802.11b/g/n Wireless LAN, web camera, HDMI, Bluetooth, USB2.0, USB3.0, with Windows 8 OS, up to 6 hours charge-in-use battery, DVDRW super Multi with 1 year warranty | 1 | unit | 3 |
| 38 | MS Office 2013 | Home & Student 1 user | 1 | unit | 3 |
| 39 | Projector | LCD Projector Portable, RGB liquid crystal shutter projection system (3LCD), White Light Output 2,600 lumens, Colour Light Output 2,600 lumens, XGA Resolution, lightweight: less than 2 kgs. | 1 | unit | 3 |
| 40 | HDMI cable | 3 meters, v1.4A HDMI cable for Projector | 1 | pc | 3 |
| 41 | Whiteboard | wooden whiteboard (2' x 3') with frame, 1 meter collapsible high stand | 1 | pc | 3 |
| 42 | PA System | 550W Portable with Trolley, with 2 wireless mics, 220V, RCA port, with warranty | 1 | unit | 3 |
| 43 | Megaphone | with speak and music switch and volume control, 25w | 1 | unit | 3 |
| 44 | First Aid Kit | First Aid Kit with the contents: betadine, alcohol, adhesive strips, band-aid, disposable gloves, hypoallergenic medical tape (1.25 cm x 9.1m), conforming bandage (5cm), triangular bandage (110m x 110cm), wound dressing no. 15, swab antiseptic, tweezers metal 8 cm, scissors disposable, safety pins assorted (12 pcs), hot and cold compress pack, first aid quick reference guide. | 1 | package | 3 |
| Plumbing NC II Tools and Equipment (for training purposes) | | | | | |
| 1 | Pipe Wrench | 12" straight, heavy duty, forged alloy steel 12", pipe capacity 2" or 50mm, weight 1.2 kg. cast-iron housing and l-beam handle with full floating forged hook jaw, featuring self cleaning threads with replaceable hook and heel jaws | 5 | pc | 3 |
| 2 | Pipe Wrench | 14" straight, heavy duty, forged alloy steel 12", pipe capacity 2" or 50mm, weight 1.6 kg. cast-iron housing and l-beam handle with full floating forged hook jaw, featuring self cleaning threads with replaceable hook and heel jaws | 5 | pc | 3 |
| 3 | Pull Push Rule | blade length 8 mtrs, blade width 1", high Impact ABS case with durable rubber corrosion resistant tru-zero end | 10 | pc | 3 |
| 4 | Hacksaw | adjustable hacksaw frame with bi-metal hacksaw blade, 24 TPI, aluminum alloy frame and handle | 5 | pc | 3 |
| 5 | Spirit Level | high impact plastic; magnetic; 3 vials; Length:24" | 5 | pc | 3 |
| 6 | Pipe Reamer | 2 " capacity, ratchet type with steel handle, 1/8-2 " capacity, suitable for use with power drives | 5 | pc | 3 |
| 7 | Pipe Cutter | max. capacity 1/8-2 " for steel or ductile iron pipes with steel handle | 5 | pc | 3 |
| 8 | Adjustable Wrench | alloy steel, 0 - 2 " jaw opening, 10" length | 5 | pc | 3 |

Handwritten signature/initials

Procurement of CMU Boxes, Tools and Equipment and Mock-ups for the Mobile Training Laboratories (MTLs).

**TESDA North Cotabato Provincial Office
Capitol Hi-way, Amas, Kidapawan City**

| NO. | ITEM | AGENCY SPECS | QTY | UNIT | No. Of Box |
|-----|-------------------------------|---|-----|------|------------|
| 9 | Mechanical Plier | mechanical, plastic dipped insulated handle, 6 " length, rust-resistant chrome finish, two position adjustable joint pliers | 5 | pc | 3 |
| 10 | Pipe Vise | capacity 2", material steel, d with swivel base with dual locking nuts, 360 degrees of rotation. | 2 | pc | 3 |
| 11 | Pipe Threader | drop head with 3 sets of head and dies, sizes (1/2", 3/4", 1") | 2 | pc | 3 |
| 12 | Portable Tri-stand Chain Vise | 1/8 to 6 in., rear pipe support, rugged tool tray capacity: 1/8" - 6", leg locking: over center tool tray | 3 | pc | 3 |
| 13 | Manual Pressure Test Pump | 6 mpa, 860 psi max. pressure, 12 L. capacity, with brass pump valve | 1 | pc | 3 |
| 14 | Socket Fusion Machine | 20 mm - 32 mm cap, 3/4", 1", 1-1/4" and 1-1/2", 220V, 1600w | 2 | pc | 3 |
| 15 | Ballpeen hammer | 12 oz., 11 1/2" overall length forged steel construction, hardened and tempered, wooden handle | 5 | pc | 3 |
| 16 | Angle Grinder | 4 "diameter, wheel cap, 220V, 60 Hz, single phase, 11,000 rpm, all-ball bearing design and metal gear | 2 | pc | 3 |
| 17 | Electric Portable Drill | 1/2 " bit jaw capacity, 220V, single phase, variable speed (0-550 rpm), heavy duty, 1/2" drill chuck | 1 | pc | 3 |
| 18 | Carpenter Steel Square | high tempered aluminum steel, 2" x 16" x 24", 5-60 and 30-degree angle markings, high tempered aluminum for maximum durability, 1/8-inch graduations for long-term visibility, body: 24 by 2-inches, tongue: 16 by 1-1/2" | 4 | pc | 3 |
| 19 | Claw Hammer | 16 oz., forged steel construction, hardened and tempered steel head, smooth face, wooden handle | 5 | pc | 3 |
| 20 | Paint Brush | 1/2" round trim brush soft bristle, tin-plated ferrules | 10 | pc | 3 |
| 21 | Hand Gloves | 5 finger, poly/cotton blend with a latex coated palm | 25 | pc | 3 |
| 22 | Safety Hard Hat | V-rib, yellow ball-cap style hard hat with 6 point ratchet-type headgear, 2 point chin strap and V rib on top, polyethylene material | 25 | pc | 3 |
| 23 | Safety Shoes | heavy duty steel toe cap, waterproof, anti static (sizes 40-42) Its anti-static and heat resistant (up to 300 degree C/572 degree F) with TPU SAFETY cell construction steel toe cap | 25 | pc | 3 |
| 24 | Safety Goggles | clear polycarbonate, woven elastic strap (adjustable) | 25 | pc | 3 |
| 25 | Water Meter | multi jet plastic meter, 1/2" NPT, 20 gpm, brass body | 1 | pc | 3 |
| 26 | Water Closet | flush type, ceramic, dimension (LxWxH): 684x430x767 mm, flushing action: siphonic, single/dual flush: single flush, flush Volume: 6L, flushing activation: front lever, rough-in: 305mm, discharge: floor cover | 1 | pc | 3 |
| 27 | Lavatory with Faucet | center hole, with mixing hot and cold faucet, ceramic, wall hung type, wall hung sink, 4-inch center faucet holes, front overflow, self-draining deck area with contoured back and side splash shields | 2 | pc | 3 |
| 28 | Kitchen Sink with Faucet | stainless steel, rust and heat resistant, grade 304, 74 cm x 51.5 cm, 16.2 mm outlet hole | 1 | pc | 3 |

7 N
H

Procurement of CMU Boxes, Tools and Equipment and Mock-ups for the Mobile Training Laboratories (MTLs).

**TESDA North Cotabato Provincial Office
Capitol Hi-way, Amas, Kidapawan City**

| NO. | ITEM | AGENCY SPECS | QTY | UNIT | No. Of Box |
|--|---------------------------|---|-----|---------|------------|
| 29 | Single Point Water Heater | 4.5kw, 220V, 60 Hz, 2 psi min water pressure, 55 psi, 2 L/min minimum water flow, 1/2" BSP | 2 | pc | 3 |
| 30 | Laptop | 15.6", Core i7, 1.40GHz, wide screen, 1TB hard drive, 8GB DDR3 memory, NVIDIA GTX 670MX graphic processor, 3GB video memory, Gigabit 10/100/1000Mbps IEEE802.11b/g/n Wireless LAN, web camera, HDMI, Bluetooth, USB2.0, USB3.0, with Windows 8 OS, up to 6 hours charge-in-use battery, DVDRW super Multi with 1 year warranty | 1 | unit | 3 |
| 31 | MS Office 2013 | Home & Student 1 user | 1 | unit | 3 |
| 32 | Projector | LCD Projector Portable, RGB liquid crystal shutter projection system (3LCD), White Light Output 2,600 lumens, Colour Light Output 2,600 lumens, XGA Resolution, lightweight: less than 2 kgs. | 1 | unit | 3 |
| 33 | HDMI cable | 3 meters, v1.4A HDMI cable for Projector | 1 | pc | 3 |
| 34 | Whiteboard | wooden whiteboard (2' x 3') with frame, 1 meter collapsible high stand | 1 | pc | 3 |
| 35 | PA System | non slip handle, rubberized 5" full expansion | 1 | unit | 3 |
| 36 | Megaphone | with speak and music switch and volume control, 25w | 1 | unit | 3 |
| 37 | First Aid Kit | First Aid Kit with the contents: betadine, alcohol, adhesive strips, band-aid, disposable gloves, hypoallergenic medical tape (1.25 cm x 9.1m), conforming bandage (5cm), triangular bandage (110m x 110cm), wound dressing no. 15, swab antiseptic, tweezers metal 8 cm, scissors disposable, safety pins assorted (12 pcs), hot and cold compress pack, first aid quick reference guide. | 1 | package | 3 |
| Small Engine Repair (Motorcycle/Small Engine Servicing NC II) Tools and Equipment (for training purposes) | | | | | |
| 1 | Impact Drive Tool | 4pcs, 1/2" Impact Driver Set, heavy duty. | 10 | set | 4 |
| 2 | Multi-Tester | analog, standard-size analog multimeter for measuring voltage, current, and resistance. An auxiliary connector is also provided for checking transistors. Specifications: •DC Voltage Range: 0 to 1000V in seven ranges •AC Voltage Range: 0 to 1000V in five ranges •DC Current Range: 0 to 250mA in four ranges •Resistance Range: x1 to 20KW in four ranges •Transistor hFE Range: -0 to 1000 •Transistors Leakage Current (ICEO) Range: -0 to 150mAAF Output Range: -10dB to +22dB | 10 | pc | 4 |
| 3 | Oiler | metal case, 1/2 liter cap | 10 | pc | 4 |
| 4 | Steel Brush | wooden handle | 10 | pc | 4 |
| 5 | Hacksaw | adjustable hacksaw frame with bi-metal hacksaw blade, 24 TPI, aluminum alloy frame and handle | 10 | pc | 4 |
| 6 | Center Punch | high speed steel, 5x125 mm | 10 | pc | 4 |
| 7 | Cold Chisel | flat blade, 1" (W), 6" (L), hardened steel | 10 | pc | 4 |

1
W
25/96

Procurement of CMU Boxes, Tools and Equipment and Mock-ups for the Mobile Training Laboratories (MTLs).

**TESDA North Cotabato Provincial Office
Capitol Hi-way, Amas, Kidapawan City**

| NO. | ITEM | AGENCY SPECS | QTY | UNIT | No. Of Box |
|-----|----------------------------|--|-----|------|------------|
| 8 | Fly Wheel/Magneto Puller | universal type, six in one fly wheel/ magneto puller | 10 | pc | 4 |
| 9 | Oil Seal Remover/Installer | pointed tip, hardened steel w/ straight handle, 3 pcs per set | 10 | set | 4 |
| 10 | Piston Ring Compressor | self locking w/ L wrench steel, range 2 1/8" to 5 inch diameter | 10 | pc | 4 |
| 11 | Valve Spring Compressor | spring loaded offset jaw overhead valve spring compressor, steel | 10 | pc | 4 |
| 12 | Clutch Assembly Remover | universal compressor clutch hub for removal and installation | 10 | pc | 4 |
| 13 | Electricians Plier | overall length 6, knife length: 5/8", material: carbon steel handle finished: plastic dipped | 10 | pc | 4 |
| 14 | Diagonal Cutting Plier | dyna grip, 152mm/6" inches carbon steel | 10 | pc | 4 |
| 15 | Mechanical Plier | 8", insulated handle | 10 | pc | 4 |
| 16 | Vise Grippped Plier | 10R straight jaw | 10 | pc | 4 |
| 17 | Feeler Gauge | 26 blade feeler gauge set, metric & English marked gauge | 10 | pc | 4 |
| 18 | Screwdriver, Flat | 8", magnetic tip, chrome vanadium, plastic handle | 10 | pc | 4 |
| 19 | Screwdriver, Philips | 8", magnetic tip, chrome vanadium, plastic handle | 10 | pc | 4 |
| 20 | Ballpeen hammer | 12 oz., 11 1/2" overall length forged steel construction, hardened and tempered, wooden handle | 10 | pc | 4 |
| 21 | Hammer, Brass/copper | 1 lb., wooden handle | 10 | pc | 4 |
| 22 | Hammer, Plastic | 1 lb, wooden handle, plastic tip hammer | 10 | pc | 4 |
| 23 | Wrench, Sparkplug | 19x16 mm, hexagonal w/ handle | 10 | pc | 4 |
| 24 | Wrench, Combination | 6mm,8mm,10mm,11mm,12mm,13mm,14mm,15mm,16mm,17mm,19mm, 21mm,22mm, 24 mm, chrome vanadium steel | 10 | set | 4 |
| 25 | Wrench, Socket | 8 - 32 mm., black, 1/2" drive | 10 | set | 4 |
| 26 | Wrench, T-type | 8, 10, 12, 14 mm | 10 | set | 4 |

1
2
3

Procurement of CMU Boxes, Tools and Equipment and Mock-ups for the Mobile Training Laboratories (MTLs).

**TESDA North Cotabato Provincial Office
Capitol Hi-way, Amas, Kidapawan City**

| NO. | ITEM | AGENCY SPECS | QTY | UNIT | No. Of Box |
|-----|---------------------|--|-----|---------|------------|
| 27 | Hand Tractor Engine | diesel engine, single piston, 4 stroke direct injection, 10-12 hp | 2 | unit | 4 |
| 28 | Laptop | 15.6", Core i7, 1.40GHz, wide screen, 1TB hard drive, 8GB DDR3 memory, NVIDIA GTX 670MX graphic processor, 3GB video memory, Gigabit 10/100/1000Mbps IEEE802.11b/g/n Wireless LAN, web camera, HDMI, Bluetooth, USB2.0, USB3.0, with Windows 8 OS, up to 6 hours charge-in-use battery, DVDRW super Multi with 1 year warranty | 1 | unit | 4 |
| 29 | MS Office 2013 | Home & Student 1 user | 1 | unit | 4 |
| 30 | Projector | LCD Projector Portable, RGB liquid crystal shutter projection system (3LCD), White Light Output 2,600 lumens, Colour Light Output 2,600 lumens, XGA Resolution, lightweight: less than 2 kgs. | 1 | unit | 4 |
| 31 | HDMI cable | 3 meters, v1.4A HDMI cable for Projector | 1 | pc | 4 |
| 32 | Whiteboard | wooden whiteboard (2' x 3') with frame, 1 meter collapsible high stand | 1 | pc | 4 |
| 33 | PA System | 550W Portable with Trolley, with 2 wireless mics, 220V, RCA port, with warranty | 1 | unit | 4 |
| 34 | Megaphone | with speak and music switch and volume control, 25w | 1 | unit | 4 |
| 35 | First Aid Kit | First Aid Kit with the contents: betadine, alcohol, adhesive strips, band-aid, disposable gloves, hypoallergenic medical tape (1.25 cm x 9.1m), conforming bandage (5cm), triangular bandage (110m x 110cm), wound dressing no. 15, swab antiseptic, tweezers metal 8 cm, scissors disposable, safety pins assorted (12 pcs), hot and cold compress pack, first aid quick reference guide. | 1 | package | 4 |

Handwritten signature and initials in the bottom right corner of the page.

**Procurement of CMU Boxes, Tools and Equipment and Mock-ups for
the Mobile Training Laboratories (MTLs).**

**TESDA North Cotabato Provincial Office
Capitol Hi-way, Amas, Kidapawan City**

| Lot No. | Item / Description | Qty. | Unit | No. of Mock-up |
|--|---|------|-------|----------------|
| Electrical Installation and Maintenance (EIM) NC II Mock-up | | | | |
| 1 | Electrical Installation Maintenance (EIM) Mock-Up | 1 | lot | 1 |
| SUPPLIES AND MATERIALS | | | | |
| 2 | Heat gun, 1200 watts | 1 | pc | 1 |
| 3 | PVC adapter with lock nuts | 20 | pc | 1 |
| 4 | Circuit breaker, 30A | 2 | pc | 1 |
| 5 | 1/2" diameter PVC pipe | 2 | meter | 1 |
| 6 | Cable ties, 100 pcs./pack | 1 | pack | 1 |
| 7 | Incandescent bulb, 220V, 25W | 5 | pc | 1 |
| 8 | One pole switch with plate, flush type | 5 | pc | 1 |
| 9 | Three way switch with plate, flush type | 5 | pc | 1 |
| 10 | Four way switch with plate, flush type | 5 | pc | 1 |
| 11 | Lamp receptacle 4" X 4" surface type | 5 | pc | 1 |
| 12 | Photo electrical (photocell) | 1 | pc | 1 |
| 13 | Convenience outlet, universal type | 5 | pc | 1 |
| 14 | Floor outlet, round type | 1 | pc | 1 |
| 15 | Ground fault current interrupter | 1 | pc | 1 |
| 16 | Circuit breaker 60A with built in housing | 1 | pc | 1 |
| 17 | Terminal block 15A 12 slots | 40 | pc | 1 |
| 18 | Automotive Wire #14 AWG (1 solid and 1 stranded) | 2 | roll | 1 |
| 19 | Terminal lug, Y type | 150 | pc | 1 |
| This include supplies and materials required in the fabrication of mock-up | | | | |
| Plumbing NC II Mock-up | | | | |
| 1 | Plumbing Mock-up (Labor Cost) | 1 | lot | 1 |
| SUPPLIES AND MATERIALS | | | | |
| 2 | 4" dia PVC Pipe (Orange) | 1 | pc | 1 |
| 3 | 4" dia. PVC Elbow 90 deg. | 1 | pc | 1 |
| 4 | 4" dia. PVC Elbow 45 deg. | 1 | pc | 1 |
| 5 | 4" dia. PVC Clean Out | 1 | pc | 1 |
| 6 | 4" x 3" PVC Wye | 1 | pc | 1 |
| 7 | 4" x 2" PVC Wye | 3 | pc | 1 |
| 8 | 3" dia. PVC pipe | 1 | pc | 1 |
| 9 | 3" PVC Elbow | 1 | pc | 1 |
| 10 | 3" PVC Elbow 45 deg. | 1 | pc | 1 |
| 11 | 3" x 2" PVC Tee | 1 | pc | 1 |
| 12 | 3" x 3" PVC Tee | 1 | pc | 1 |
| 13 | 2" dia PVC Pipe | 2 | pc | 1 |
| 14 | 2" dia. PVC Elbow 45 deg. | 3 | pc | 1 |
| 15 | 2" dia. PVC Elbow 90 deg. | 3 | pc | 1 |
| 16 | 2" PVC Tee | 4 | pc | 1 |
| 17 | 2" PVC P-trap | 2 | pc | 1 |
| 18 | 1/2" dia. PPr pipe | 2 | pc | 1 |
| 19 | 1/2" dia. PPr elbow | 7 | pc | 1 |
| 20 | 1/2" dia. PPr tee | 4 | pc | 1 |
| 21 | 1/2" dia. PPr elbow connector | 6 | pc | 1 |
| 22 | 1/2" dia. PPr male connector | 2 | pc | 1 |
| 23 | 1/2" dia. PPr union | 3 | pc | 1 |
| 24 | 1/2" dia. PPr coupling | 4 | pc | 1 |

1
N
96

**Procurement of CMU Boxes, Tools and Equipment and Mock-ups for
the Mobile Training Laboratories (MTLs).**

**TESDA North Cotabato Provincial Office
Capitol Hi-way, Amas, Kidapawan City**

| Lot No. | Item / Description | Qty. | Unit | No. of Mock-up |
|--|--|------|-------|----------------|
| 25 | Urinal 480mm X 730mm X 730mm with complete accessories | 1 | unit | 1 |
| 26 | Shower head with complete accessories | 1 | unit | 1 |
| 27 | 1/2 x 7/8 flexible hose | 1 | pc | 1 |
| 28 | 1/2 x 1/2" angle valve | 3 | pc | 1 |
| 29 | 3/4" x 4' x 8' Marine Plywood | 1 | pc | 1 |
| 30 | 2" x 2" x 12' Lumber | 4 | pc | 1 |
| 31 | Teflon Tape | 10 | pc | 1 |
| 32 | Metal hinges 2" X 4", heavy duty | 3 | pc | 1 |
| This include supplies and materials required in the fabrication of mock-up | | | | |
| Small Engine Repair (Motorcycle/Small Engine Servicing NC II) Tools and Equipment Mock-up | | | | |
| 1 | Motorcycle/Small Engine Collapsible Mock-Up | 1 | lot | 1 |
| SUPPLIES AND MATERIALS: | | | | |
| 2 | Auto wire, stranded # 16 | 1 | roll | 1 |
| 3 | Electrical tape, large black | 2 | pc | 1 |
| 4 | Head light assembly, 12 volts rectangular | 1 | pc | 1 |
| 5 | signal light assembly, 12 volts | 2 | pair | 1 |
| 6 | Horn, 12 volts | 1 | pc | 1 |
| 7 | Stop light switch, push button | 1 | pc | 1 |
| 8 | Signal light switch, double throw, toggle switch | 1 | pc | 1 |
| 9 | Ignition switch, gas engine type | 1 | pc | 1 |
| 10 | Signal light relay, 12 volts | 1 | pc | 1 |
| 11 | Push button switch for horn | 1 | pc | 1 |
| 12 | Motorcycle storage battery, 12 volts maintenance free | 1 | pc | 1 |
| 13 | Harness cover, 3/8" diameter (140/4) | 4 | meter | 1 |
| 14 | Harness connector, 6 terminals | 4 | pc | 1 |
| 15 | Male terminal, flat | 30 | pc | 1 |
| 16 | Female terminal, flat | 30 | pc | 1 |
| 17 | Headlight switch or toggle switch, single throw | 1 | pc | 1 |
| 18 | Crocodile clip, medium, red and black | 1 | pair | 1 |
| 19 | 3/16" diameter X 3/4" stove bolt, stainless | 20 | pc | 1 |
| 20 | 3/16" diameter hole, eye terminal | 10 | pc | 1 |
| 21 | Four stroke motorcycle engine, 125 or 155cc, surplus | 1 | unit | 1 |
| This include supplies and materials required in the fabrication of mock-up | | | | |

Procurement of CMU Boxes, Tools and Equipment and Mock-ups for the Mobile Training Laboratories (MTLs).

TESDA Sarangani Provincial Office

Door 5-7, 2nd Floor One Roma Square Aparante Ave. City Heights, General Santos City

| NO. | ITEM | AGENCY SPECS | QTY | UNIT | No. Of Box |
|---|--|---|-----|------|------------|
| Appliance Repair NC II Tools and Equipment (for training purposes) | | | | | |
| 1 | Soldering Iron | dual wattage, 25 watts/ 120watts, 220 volt 60 Hz, with long life tip, "gun type" | 25 | unit | 3 |
| 2 | Desoldering Tools | desoldering pump with precision regulated return, replacement tip compact, metal housing | 25 | unit | 3 |
| 3 | Screw driver assorted (Phillips and slotted) | 12x7x1 inches, 6 pieces per set, plastic handle | 5 | set | 3 |
| 4 | Long Nose Plier | dyna grip, 152mm/6" inches carbon steel | 5 | pc | 3 |
| 5 | Diagonal Cutting Plier | dyna grip, 152mm/6" inches carbon steel | 5 | pc | 3 |
| 6 | Nut Drivers | rust-resistant, nickel-plated bar, hexagonal shank, includes: 5mm, 6mm, 7mm, 8mm, 9mm, 10mm, 11mm | 5 | set | 3 |
| 7 | Wrench, Combination | 8mm,8mm,10mm,11mm,12mm,13mm,14mm,15mm, 16mm,17mm,19mm, 21mm,22mm, 24 mm, chrome vanadium steel | 5 | set | 3 |
| 8 | Wire Stripper | automatic, cap. 1.5mm to 3.5mm | 10 | pc | 3 |
| 9 | Ballpeen hammer | 12 oz, 11 1/2" overall length forged steel construction, hardened and tempered, wooden handle | 5 | pc | 3 |
| 10 | Flashlight | LED, 3 volts/6 volts, rechargeable | 5 | pc | 3 |
| 11 | Detector Light | test light, 220 volts | 5 | pc | 3 |
| 12 | Paint Brush | 4 inches width, wooden handle | 25 | pc | 3 |
| 13 | Microwave Oven | power capacity: 220V 1300 watts, interior capacity 20 liters, 8 programmes, defrost option, 26cm diameter rotating turntable, digital | 1 | unit | 3 |
| 14 | Washing Machine with dryer | power capacity: 500w, 220V, rust proof body, gear drive system, dolphin drive pulsator, washing capacity (dry weight) 7.5kg, spinning capacity (dry weight) 5.5kg, width should be more than 50 cm and length of not more than 100 cm | 1 | unit | 3 |
| 15 | Electric Fan | power capacity: 220V, 100w, 60Hz, 3 speed rotary switch, 18 inch metal blade, round/stable plastic base, thermal fuse protection, adjustable height stand fan | 1 | unit | 3 |
| 16 | Electric Rice Cooker | power capacity: 700w, 220V, 60Hz, automatic cooking feature, auto shutoff, glass lid, non-stick coated aluminum pan, includes measuring cup and rice scoop | 1 | unit | 3 |
| 17 | Electric Flat Iron | power capacity:1000w, 220V, 60 Hz, non-stick Teflon soleplate, thermal fuse protected, variable temperature control, automatic thermostat Control, pilot lamp indicator | 1 | unit | 3 |

Handwritten signature and initials

Procurement of CMU Boxes, Tools and Equipment and Mock-ups for the Mobile Training Laboratories (MTLs).

TESDA Sarangani Provincial Office

Door 5-7, 2nd Floor One Roma Square Aparante Ave. City Heights, General Santos City

| NO. | ITEM | AGENCY SPECS | QTY | UNIT | No. Of Box |
|-----|----------------|--|-----|------|------------|
| 18 | Coffee Maker | power capacity: 550w, 220V, 60Hz, glass pitcher, anti-drip feature, 6 cup water capacity, water level indicator, swing-out filter basket | 1 | unit | 3 |
| 19 | Oven Toaster | power capacity: 1000w, 220V, 60Hz, stainless steel, 8 liter capacity, 15 minute timer, slide out chrome crumb rack, includes baking tray | 1 | unit | 3 |
| 20 | Blender | 1.5 liter capacity, rated voltage, 230V, 60Hz, power consumption: 300 watts, sharp stainless steel blade, safety lock switch, with plastic stirrer for easy mixing | 1 | unit | 3 |
| 21 | Multi Tester | analog, standard size analog multimeter for measuring voltage, current and resistance. An auxiliary connector is also provided for checking transistors. SPECIFICATION: <ul style="list-style-type: none"> •DC Voltage Range: 0 to 1000V in seven ranges •AC Voltage Range: 0 to 1000V in five ranges •DC Current Range: 0 to 250mA in four ranges •Resistance Range: x1 to 200MEG in four ranges •Transistor hFE Range: -0 to 1000 •Transistors Leakage Current (ICEO) Range: -0 to 150mAAF •Output Range: -10dB to +22dB | 25 | unit | 3 |
| 22 | Multi Tester | Digital Multi meters are standard digital multimeter for measuring voltage, current, and resistance with 3-1/2 digit LCD display. This meter measures only 138mm x 70mm x 32mm and weighs approximately 140 grams, including battery. SPECIFICATION: <ul style="list-style-type: none"> •DC Voltage Range: 200mV to 600V in five ranges (auto ranging) •AC Voltage Range: 2V to 600V in four ranges (auto ranging) •DC Current Range: 200mA to 10A in six ranges •Resistance Range: 200 Ohms to 20M in six ranges •Transistor hFE Test Range: 0 to 2000 | 25 | unit | 3 |
| 23 | Laptop | 15.6", Core i7, 1.40GHz, wide screen, 1TB hard drive, 8GB DDR3 memory, NVIDIA GTX 670MX graphic processor, 3GB video memory, Gigabit 10/100/1000Mbps IEEE802.11b/g/n Wireless LAN, web camera, HDMI, Bluetooth, USB2.0, USB3.0, with Windows 8 OS, up to 6 hours charge-in-use battery, DVDRW super Multi with 1 year warranty | 1 | unit | 3 |
| 24 | MS Office 2013 | Home & Student 1 user | 1 | unit | 3 |
| 25 | Projector | LCD Projector Portable, RGB liquid crystal shutter projection system (3LCD), White Light Output 2,600 lumens, Colour Light Output 2,600 lumens, XGA Resolution, lightweight: less than 2 kgs. | 1 | unit | 3 |

Handwritten signature and initials

Procurement of CMU Boxes, Tools and Equipment and Mock-ups for the Mobile Training Laboratories (MTLs).

TESDA Sarangani Provincial Office

Door 5-7, 2nd Floor One Roma Square Aparante Ave. City Heights, General Santos City

| NO. | ITEM | AGENCY SPECS | QTY | UNIT | No. Of Box |
|---|-----------------------|--|-----|---------|------------|
| 26 | HDMI cable | 3 meters, v1.4A HDMI cable for Projector | 1 | pc | 3 |
| 27 | Whiteboard | wooden whiteboard (2' x 3') with frame, 1 meter collapsible high stand | 1 | pc | 3 |
| 28 | PA System | 550W Portable with Trolley, with 2 wireless mics, 220V, RCA port, with warranty | 1 | unit | 3 |
| 29 | Megaphone | with speak and music switch and volume control, 25w | 1 | unit | 3 |
| 30 | First Aid Kit | First Aid Kit with the contents: betadine, alcohol, adhesive strips, band-aid, disposable gloves, hypoallergenic medical tape (1.25 cm x 9.1m), conforming bandage (5cm), triangular bandage (110m x 110cm), wound dressing no. 15, swab antiseptic, tweezers metal 8 cm, scissors disposable, safety pins assorted (12 pcs), hot and cold compress pack, first aid quick reference guide. | 1 | package | 3 |
| Bread and Pastry NC II Tools and Equipment (for training purposes) | | | | | |
| 1 | Measuring Cup, dry | stainless steel, 4 pcs/set (1c, 1/2c, 1/3c & 1/4c) | 12 | pc | 3 |
| 2 | Measuring Cup, liquid | glass graduated, 250 ml capacity | 12 | pc | 3 |
| 3 | Measuring Spoon | Stainless steel 6 pcs/set(1/8 tsp, 1/4 tsp, 1/2tsp, 1 tsp 1/2 tbsp, 1 tbsp) | 12 | set | 3 |
| 4 | Cake Turn Table | plastic cake turntable with locking switch, rubberized feet, white, 12.6x12.6x3.54 inches (LxWxH) | 10 | pc | 3 |
| 5 | Decorating Tips | stainless steel, 24-piece cake decorating tip set, package size: 17cm x 12cm x 5cm (6.69 x 4.72 x 1.97inches) | 25 | set | 3 |
| 6 | Rolling Pin | wooden, size 33.5 x 5cm, light weight comfortable grip | 25 | pc | 3 |
| 7 | Pie Plate, size 6" | aluminum pie pan, 6" diameter x 5/8 in deep, heavy weight round pan | 10 | pc | 3 |
| 8 | Pie Plate, size 8" | pie pan, 8" aluminum deep dish pie pan, standard weight aluminum, 8" top outside diameter | 10 | pc | 3 |
| 9 | Pie Plate, size 10" | deep aluminum pie pan, 10" diameter, depth 1-1/4", made of 0.7mm thick satin finished aluminum | 10 | pc | 3 |
| 10 | Jelly Roll Pan | aluminum, dimension: 2" x 13 x 8" (HxWxD) | 10 | pc | 3 |
| 11 | Cake Spring Form Pan | heavy aluminum spring form pan, heavy duty frame, spring form sides for easy removal, size 9 x 3" | 10 | pc | 3 |
| 12 | Pie Cutter | triple riveted pizza cutter, made of stainless steel, rolling wheel slicer, 6" | 10 | pc | 3 |
| 13 | Rubber Scraper | rubber head, high heat resistant, flexible, 12", color white | 25 | pc | 3 |

T
2
9

Procurement of CMU Boxes, Tools and Equipment and Mock-ups for the Mobile Training Laboratories (MTLs).

TESDA Sarangani Provincial Office

Door 5-7, 2nd Floor One Roma Square Aparante Ave. City Heights, General Santos City

| NO. | ITEM | AGENCY SPECS | QTY | UNIT | No. Of Box |
|-----|----------------------|--|-----|------|------------|
| 14 | Spatula | Stainless steel straight blade, 14 inches long with wood handle | 25 | pc | 3 |
| 15 | Cake Stand with tier | 3 tier cake round acrylic cake stand, 3 plates clear, size: 15cm, 20cm, 25cm, 10 inches gap between each tier | 6 | set | 3 |
| 16 | Saucepan | Stainless steel with cover and handle 26cm | 15 | pc | 3 |
| 17 | Ladle | stainless steel, 12 inches, comes with brush finished handle, hole in the handle for easy hanging | 10 | pc | 3 |
| 18 | Chef Knife | 8 inch, stainless steel full tang blade with plastic handle | 12 | pc | 3 |
| 19 | Chopping Board | 12 x 17 inches, polyethylene, easy grip handle, white color | 10 | pc | 3 |
| 20 | Weighing Scale | manual, maximum weight capacity 2kg, graduated by grams, removable and washable tray | 6 | pc | 3 |
| 21 | Grater | made of nonreactive stainless steel easy grip handle | 10 | pc | 3 |
| 22 | Wooden Spoon | wooden turner, size 12 inches | 25 | pc | 3 |
| 23 | Piping Bag | 12 Inches, light weight, reusable, flexible polyester, coated can be boiled, dishwasher safe | 25 | pc | 3 |
| 24 | Mixing Bowl | 12 inches diameter, 8-9 quarts capacity, stainless | 15 | pc | 3 |
| 25 | Wire Whisk | 8"/20cm, aluminum, balloon style | 25 | pc | 3 |
| 26 | Electric Mixer | 4 qt. stainless steel bowl, 5 speeds & quick burst button, bowl rest TM mixer stabilizer, doubles as a hand mixer, 220V, 290-watts peak power, versatile attachment set includes traditional beaters, whisk and dough hooks, brushed stainless steel | 5 | unit | 3 |
| 27 | Dough Cutter | dough scraper 6" wide x 4", high polished stainless steel blade | 10 | pc | 3 |
| 28 | Oven (gas) | stainless door, 2 trays oven with tempered glass window, 22-25" collapsible stand | 1 | unit | 3 |
| 29 | Pastry Brush | pastry/basting brush, natural wood handle brushes, 1.5" size | 10 | pc | 3 |
| 30 | Bread Knife | 8", serrated edge stain free high-carbon steel blade texture red polypropylene handle | 10 | pc | 3 |
| 31 | Flour Sifter | stainless steel mesh flour sifter strainer, 12" | 10 | pc | 3 |
| 32 | Baking Sheet | aluminum, 13" x 18" | 15 | pc | 3 |
| 33 | Muffin Pans | 12 holes, 3 oz. capacity per holes, aluminum | 25 | pc | 3 |
| 34 | Working Table | high quality stainless steel foldable tables dimension: 3ft x 3ft | 4 | pc | 3 |
| 35 | Gas Stove with tank | 2 burner, made from stainless top body, automatic ignition, with complete accessories | 2 | pc | 3 |

7
2
95

Procurement of CMU Boxes, Tools and Equipment and Mock-ups for the Mobile Training Laboratories (MTLs).

TESDA Sarangani Provincial Office

Door 5-7, 2nd Floor One Roma Square Aparante Ave. City Heights, General Santos City

| NO. | ITEM | AGENCY SPECS | QTY | UNIT | No. Of Box |
|--|----------------|--|-----|---------|------------|
| 36 | Kitchen Sink | Kitchen sink, portable single bowl sink stainless steel, with steel collapsible frame legs, with drain hose, Dimension 50cmx50cmx30cm | 1 | pc | 3 |
| 37 | Weighing Scale | digital, 1000g, maximum weight capacity, battery operated (AAA battery) 0.1 g to 1000g , LCD display battery included. | 5 | pc | 3 |
| 38 | Laptop | 15.6", Core i7, 1.40GHz, wide screen, 1TB hard drive, 8GB DDR3 memory, NVIDIA GTX 670MX graphic processor, 3GB video memory, Gigabit 10/100/1000Mbps IEEE802.11b/g/n Wireless LAN, web camera, HDMI, Bluetooth, USB2.0, USB3.0, with Windows 8 OS, up to 6 hours charge-in-use battery, DVDRW super Multi with 1 year warranty | 1 | unit | 3 |
| 39 | MS Office 2013 | Home & Student 1 user | 1 | unit | 3 |
| 40 | Projector | LCD Projector Portable, RGB liquid crystal shutter projection system (3LCD), White Light Output 2,600 lumens, Colour Light Output 2,600 lumens, XGA Resolution, lightweight: less than 2 kgs. | 1 | unit | 3 |
| 41 | HDMI cable | 3 meters, v1.4A HDMI cable for Projector | 1 | pc | 3 |
| 42 | Whiteboard | wooden whiteboard (2' x 3') with frame, 1 meter collapsible high stand | 1 | pc | 3 |
| 43 | PA System | 550W Portable with Trolley, with 2 wireless mics, 220V, RCA port, with warranty | 1 | unit | 3 |
| 44 | Megaphone | with speak and music switch and volume control, 25w | 1 | unit | 3 |
| 45 | First Aid Kit | First Aid Kit with the contents: betadine, alcohol, adhesive strips, band-aid, disposable gloves, hypoallergenic medical tape (1.25 cm x 9.1m), conforming bandage (5cm), triangular bandage (110m x 110cm), wound dressing no. 15, swab antiseptic, tweezers metal 8 cm, scissors disposable, safety pins assorted (12 pcs), hot and cold compress pack, first aid quick reference guide. | 1 | package | 3 |
| Cookery NC II Tools and Equipment (for training purposes) | | | | | |
| 1 | Chef Knife | 8 inch, stainless steel full tang blade with plastic handle | 10 | pc | 3 |
| 2 | Boning Knife | 6 inches, stainless steel with sharp cutting edge with plastic handle | 8 | pc | 3 |
| 3 | Oyster Knife | 7 inches length (3 inches blade and 4 inches handle), stainless steel blade, with comfortable plastic handle | 4 | pc | 3 |
| 4 | Cleaver Knife | 7 inches, stain resistant carbon steel blade | 2 | pc | 3 |
| 5 | Tenderizer | with flat and textured side, non slip, 10 inches 25.5 cm, solid aluminum construction | 8 | pc | 3 |

1
2
96

Procurement of CMU Boxes, Tools and Equipment and Mock-ups for the Mobile Training Laboratories (MTLs).

TESDA Sarangani Provincial Office

Door 5-7, 2nd Floor One Roma Square Aparante Ave. City Heights, General Santos City

| NO. | ITEM | AGENCY SPECS | QTY | UNIT | No. Of Box |
|-----|--------------------------|--|-----|------|------------|
| 6 | Skimmer | fine, extra fine mesh, 6 inches diameter, with stainless handle | 8 | pc | 3 |
| 7 | Wire Skimmer | small, nickel plated wire oil skimmer, 16 inches long overall, 5 inches diameter bowl | 8 | pc | 3 |
| 8 | Skimmer | spider, 5 inches diameter, natural bamboo handle, constructed of durable stainless steel with versatile woven design | 8 | pc | 3 |
| 9 | Strainer, small | fine, 6" diameter, with stainless handle | 8 | pc | 3 |
| 10 | Siever | small 12" diameter, stainless | 8 | pc | 3 |
| 11 | Strainer, medium | medium, fine stainless steel mesh, 9 inches diameter with stainless handle | 8 | pc | 3 |
| 12 | Turner | solid, stainless steel, with handy loop for hanging, 12 inches long | 8 | pc | 3 |
| 13 | Spatula | Stainless steel straight blade, 14 inches long with wood handle | 8 | pc | 3 |
| 14 | Wooden Spatula | large comfortable handle, 12 inches long, wooden | 8 | pc | 3 |
| 15 | Piping Bag | 12 inches, light weight, reusable, flexible polyester, coated, can be boiled, dishwasher safe | 8 | pc | 3 |
| 16 | Pastry Tubes | steel stainless, set of 24 pcs, different/assorted icing nozzles medium size, constructed of 18/8 quality stainless steel, comes in plastic storage box with lid | 8 | set | 3 |
| 17 | Strainer, chinois medium | medium, 8 inches diameter, stainless steel including handle | 3 | pc | 3 |
| 18 | Strainer, chinois small | small, 5 inches diameter, stainless steel including handle | 2 | pc | 3 |
| 19 | Funnel | general purpose, hard plastic, comes in 4 different sizes (small, medium, large, extra large) | 4 | set | 3 |
| 20 | Measuring Spoon | Stainless steel 6 pcs/set (1/8 tsp, 1/4 tsp, 1/2 tsp, 1 tsp, 1/2 tbsp, 1 tbsp) | 6 | set | 3 |
| 21 | Food Tong | 12 inches long, stainless steel, and wide shell head with locking | 8 | pc | 3 |
| 22 | Measuring Cup, liquid | glass graduated, 250 ml capacity | 8 | pc | 3 |
| 23 | Ice Cream Scooper | set of three, stainless steel (2 oz, 4 oz and 6 oz) | 2 | set | 3 |
| 24 | Cheese Cloth | 100% cotton 1 yard | 10 | pc | 3 |
| 25 | Serving Spoon | stainless steel, 9 inches long | 24 | pc | 3 |
| 26 | Pepper and Salt Mill | 2 in 1, wooden, 8" | 4 | pc | 3 |
| 27 | Weighing Scale | analog weighing scale; maximum weight capacity, 5 kg, graduated by grams, removable and washable tray | 2 | unit | 3 |

1
2
96

Procurement of CMU Boxes, Tools and Equipment and Mock-ups for the Mobile Training Laboratories (MTLs).

TESDA Sarangani Provincial Office

Door 5-7, 2nd Floor One Roma Square Aparante Ave. City Heights, General Santos City

| NO. | ITEM | AGENCY SPECS | QTY | UNIT | No. Of Box |
|-----|------------------------|--|-----|------|------------|
| 28 | Weighing Scale | digital, 1000g, maximum weight capacity, battery operated (AAA battery) 0.1 g to 1000g , LCD display battery included. | 2 | unit | 3 |
| 29 | Apple Corer | corer head comfortable on slip handle, corer head is stainless steel | 4 | pc | 3 |
| 30 | Wire Whisk | 8"/20cm, aluminum, balloon style | 8 | pc | 3 |
| 31 | Wire Whisk, medium | medium, 10 inches/25 cm, aluminum, balloon style | 8 | pc | 3 |
| 32 | Wire Whisk, large | heavy duty, stainless steel, 14 inches, balloon style | 2 | pc | 3 |
| 33 | Measuring Cup, dry | stainless steel, 4 pcs/set (1c , 1/2c, 1/3c & 1/4c) | 1 | set | 3 |
| 34 | Chopping Board | 12 x17 inches, polyethylene, easy grip handle, white color | 10 | pc | 3 |
| 35 | Kitchen Scissors | stainless steel blade, size 2 cm x 12 cm x 27 cm, durable and sturdy handle with comfortable grip | 8 | pc | 3 |
| 36 | Soup Ladle | 3 oz capacity, stainless steel, with handle, round bottom | 8 | pc | 3 |
| 37 | Soup Ladle | 6 oz capacity, stainless steel handle, round bottom | 8 | pc | 3 |
| 38 | Soup Ladle | 8 oz capacity, stainless steel handle, round bottom | 3 | pc | 3 |
| 39 | Soup Ladle | 12 oz capacity, stainless handle, round bottom, | 2 | pc | 3 |
| 40 | Mixing Bowl | 12 inches diameter, 8-9 quarts capacity , stainless | 10 | pc | 3 |
| 41 | Kitchen Spoon | solid, stainless steel handle, comfortable non slip handle, round handle 4.5 x2.5 inches | 8 | pc | 3 |
| 42 | Kitchen Spoon | slotted, stainless steel, comfortable non slip handle, round handle 10 x 2.5 inches w/ hole | 8 | pc | 3 |
| 43 | Kitchen Fork | 7.5 cm x 4.5 cm x 37 cm or 10.5 inches, stainless steel, with 2 prongs, round handle | 8 | pc | 3 |
| 44 | Carving Fork | 10.5 inches, stainless steel, with 2 prongs, round handle | 3 | pc | 3 |
| 45 | Pocket Pin Thermometer | analog, temperature range from 0oF to 220 of, dial type | 3 | pc | 3 |
| 46 | Peeler | Straight blade type, dual stainless steel blade, metal handle 5",2"handle,3"blade | 8 | pc | 3 |
| 47 | Stockpot | stainiess, 17 quarts capacity (22.7 lit), 12 inches diameter (30.5 cm), depth 31 cm, 4 mm thickness | 2 | pc | 3 |
| 48 | Frying pan | pan, large, non stick, 26 cm diameter | 2 | pc | 3 |
| 49 | Colander | medium, stainless steel, 8 quarts capacity, with base | 2 | pc | 3 |
| 50 | Fish Poacher | medium, 18 inches (L) and 6 inches(w), stainless steel, with handle | 1 | pc | 3 |

*T
N
af
96*

Procurement of CMU Boxes, Tools and Equipment and Mock-ups for the Mobile Training Laboratories (MTLs).

TESDA Sarangani Provincial Office

Door 5-7, 2nd Floor One Roma Square Aparante Ave. City Heights, General Santos City

| NO. | ITEM | AGENCY SPECS | QTY | UNIT | No. Of Box |
|-----|---------------------|--|-----|------|------------|
| 51 | Casserole | small, stainless steel, 20 cm diameter, with cover | 8 | pc | 3 |
| 52 | Casserole | medium, stainless steel, 24 cm diameter with cover | 4 | pc | 3 |
| 53 | Double Boiler | medium, made from stainless steel, 2 quarts capacity, with lid cover | 1 | pc | 3 |
| 54 | Paellera | 40 cm diameter, (50 cm with handle), constructed of carbon steel, riveted secure melt handle, safe for all heating surfaces including induction | 4 | pc | 3 |
| 55 | Baking Tray | small, main material is carbon, rectangular, size 14 x 10 inches | 8 | pc | 3 |
| 56 | Utility Tray | hard plastic tray, rectangular 14x18 inches | 12 | pc | 3 |
| 57 | Fire Extinguisher | cylinder type, multipurpose ABC dry chemical, powder aluminum valve coated, rechargeable, 5 lbs capacity, with pressure gauge that allows for immediate pressure status check, with wall hanger, meets requirements for underwriter laboratory (UJ) | 1 | unit | 3 |
| 58 | Blender | 1.5 liter capacity, rated voltage, 230V, 60Hz, power consumption: 300 watts, sharp stainless steel blade, safety lock switch, with plastic stirrer for easy mixing | 1 | unit | 3 |
| 59 | Pressure Cooker | aluminum, 2 mm, 6 quarts capacity, pressured handle, central pressure valve with self locking mechanism | 1 | pc | 3 |
| 60 | Gas Stove with tank | 2 burner, made from stainless top body, automatic ignition, with complete accessories | 4 | unit | 3 |
| 61 | Working Table | high quality stainless steel foldable tables dimension: 3ft x 3ft | 4 | pc | 3 |
| 62 | Kitchen Sink | Kitchen sink, portable single bowl sink stainless steel, with steel collapsible frame legs, with drain hose, Dimension 50cmx50cmx30cm | 1 | unit | 3 |
| 63 | Laptop | 15.6", Core i7, 1.40GHz, wide screen, 1TB hard drive, 8GB DDR3 memory, NVIDIA GTX 670MX graphic processor, 3GB video memory, Gigabit 10/100/1000Mbps IEEE802.11b/g/n Wireless LAN, web camera, HDMI, Bluetooth, USB2.0, USB3.0, with Windows 8 OS, up to 6 hours charge-in-use battery, DVDRW super Multi with 1 year warranty | 1 | unit | 3 |
| 64 | MS Office 2013 | Home & Student 1 user | 1 | unit | 3 |
| 65 | Projector | LCD Projector Portable, RGB liquid crystal shutter projection system (3LCD), White Light Output 2,600 lumens, Colour Light Output 2,600 lumens, XGA Resolution, lightweight: less than 2 kgs. | 1 | unit | 3 |
| 66 | HDMI cable | 3 meters, v1.4A HDMI cable for Projector | 1 | pc | 3 |
| 67 | Whiteboard | wooden whiteboard (2' x 3') with frame, 1 meter collapsible high stand | 1 | pc | 3 |

Handwritten signature and initials

Procurement of CMU Boxes, Tools and Equipment and Mock-ups for the Mobile Training Laboratories (MTLs).

TESDA Sarangani Provincial Office

Door 5-7, 2nd Floor One Roma Square Aparante Ave. City Heights, General Santos City

| NO. | ITEM | AGENCY SPECS | QTY | UNIT | No. Of Box |
|--|-----------------------|--|-----|---------|------------|
| 68 | PA System | 550W Portable with Trolley, with 2 wireless mics, 220V, RCA port, with warranty | 1 | unit | 3 |
| 69 | Megaphone | with speak and music switch and volume control, 25w | 1 | unit | 3 |
| 70 | First Aid Kit | First Aid Kit with the contents: betadine, alcohol, adhesive strips, band-aid, disposable gloves, hypoallergenic medical tape (1.25 cm x 9.1m), conforming bandage (5cm), triangular bandage (110m x 110cm), wound dressing no. 15, swab antiseptic, tweezers metal 8 cm, scissors disposable, safety pins assorted (12 pcs), hot and cold compress pack, first aid quick reference guide. | 1 | package | 3 |
| Electrical Installation and Maintenance (EIM) NC II Tools and Equipment (for training purposes) | | | | | |
| 1 | Spirit Level | high impact plastic; magnetic; 3 vials; Length:24" | 1 | pc | 2 |
| 2 | Hacksaw | adjustable hacksaw frame with bi-metal hacksaw blade, 24 TPI, aluminum alloy frame and handle | 5 | pc | 2 |
| 3 | Pipe Cutter | max. capacity 1/8-2 " for steel or ductile iron pipes with steel handle | 2 | pc | 2 |
| 4 | Pipe Reamer | 2 " capacity, ratchet type with steel handle, 1/8-2 " capacity, suitable for use with power drives | 2 | pc | 2 |
| 5 | Pipe Threader | drop head with 3 sets of head and dies, sizes (1/2", 3/4", 1") | 2 | unit | 2 |
| 6 | Pipe Bender | manual, 1/2-3/4 inch bending radius, ductile high strength iron | 2 | unit | 2 |
| 7 | Electricians Plier | overall length 6, knife length: 5/8", material: carbon steel handle finished: plastic dipped | 25 | pc | 2 |
| 8 | Long Nose Plier | dyna grip, 152mm/6" inches carbon steel | 25 | pc | 2 |
| 9 | Phillips Screw Driver | 1x75, PH 2 x 100, PH 2x125 plastic and rubberized handle chrome vanadium, shank 4" | 25 | set | 2 |
| 10 | Flat Screw Driver | 3x75, 5x100, 6x125 plastic and rubberized handle chrome vanadium shank 4" | 25 | set | 2 |
| 11 | Wrench, Combination | 6mm,8mm,10mm,11mm,12mm,13mm,14mm,15mm, 16mm,17mm,19mm, 21mm,22mm, 24 mm, chrome vanadium steel | 5 | set | 2 |
| 12 | Wire Stripper | automatic, cap. 1.5mm to 3.5mm | 10 | pc | 2 |
| 13 | Electrician Knife | blade length 3", taper ground cutlery single steel blade, ergonomically designed slip resistant grip | 25 | pc | 2 |
| 14 | Tool Holster | leather, 3 pocket & 4 holes with belt | 25 | pc | 2 |
| 15 | Pull Push Rule | blade length 8 mtrs, blade width 1", high impact ABS case with durable rubber corrosion resistant tru-zero end | 25 | pc | 2 |
| 16 | Claw Hammer | 16 oz., forged steel construction, hardened and tempered steel head, smooth face, wooden handle | 10 | pc | 2 |
| 17 | Heat Gun | 1600 watts, 230v,60 Hz, 12.5 amp. dual temperature, with different nozzle | 2 | unit | 2 |
| 18 | Power Drill | drilling cap.:10mm, cap. wood: 20mm, wattage 350w, no load speed: 0-2500rpm, weight 1.1 kg., Rev.- for rotation, 3/8" capacity. 220VAC, 60Hz | 2 | unit | 2 |

T
N
96

Procurement of CMU Boxes, Tools and Equipment and Mock-ups for the Mobile Training Laboratories (MTLs).

TESDA Sarangani Provincial Office

Door 5-7, 2nd Floor One Roma Square Aparante Ave. City Heights, General Santos City

| NO. | ITEM | AGENCY SPECS | QTY | UNIT | No. Of Box |
|---|----------------|---|-----|---------|------------|
| 19 | Multi-Tester | analog, standard-size analog multimeter for measuring voltage, current, and resistance. An auxiliary connector is also provided for checking transistors. Specifications: •DC Voltage Range: 0 to 1000V in seven ranges •AC Voltage Range: 0 to 1000V in five ranges •DC Current Range: 0 to 250mA in four ranges •Resistance Range: x1 to 20KW in four ranges •Transistor hFE Range: -0 to 1000 •Transistors Leakage Current (ICEO) Range: -0 to 150mAAF Output Range: -10dB to +22dB | 5 | unit | 2 |
| 20 | Clamp Ammeter | digital max. AC voltage measurement 600V, max. AC current measurement 400Aac, max. DC voltage measurement 600Vdc, max. resistance measurement 400ohms, battery type AAA, clamp meter type, continuity current, frequency, resistance, voltage, display type LCD, jaw capacity, bus bars 10x34mm, safety category voltage, 300V, 600V | 2 | unit | 2 |
| 21 | Pipe Vise | capacity 2", material steel, d with swivel base with dual locking nuts, 360 degrees of rotation. | 2 | pc | 2 |
| 22 | Laptop | 15.6", Core i7, 1.40GHz, wide screen, 1TB hard drive, 8GB DDR3 memory, NVIDIA GTX 670MX graphic processor, 3GB video memory, Gigabit 10/100/1000Mbps IEEE802.11b/g/n Wireless LAN, web camera, HDMI, Bluetooth, USB2.0, USB3.0, with Windows 8 OS, up to 6 hours charge-in-use battery, DVDRW super Multi with 1 year warranty | 1 | unit | 2 |
| 23 | MS Office 2013 | Home & Student 1 user | 1 | unit | 2 |
| 24 | Projector | LCD Projector Portable, RGB liquid crystal shutter projection system (3LCD), White Light Output 2,600 lumens, Colour Light Output 2,600 lumens, XGA Resolution, lightweight: less than 2 kgs. | 1 | unit | 2 |
| 25 | HDMI cable | 3 meters, v1.4A HDMI cable for Projector | 1 | pc | 2 |
| 26 | Whiteboard | wooden whiteboard (2' x 3') with frame, 1 meter collapsible high stand | 1 | pc | 2 |
| 27 | PA System | 550W Portable with Trolley, with 2 wireless mics, 220V, RCA port, with warranty | 1 | unit | 2 |
| 28 | Megaphone | with speak and music switch and volume control, 25w | 1 | unit | 2 |
| 29 | First Aid Kit | First Aid Kit with the contents: betadine, alcohol, adhesive strips, band-aid, disposable gloves, hypoallergenic medical tape (1.25 cm x 9.1m), conforming bandage (5cm), triangular bandage (110m x 110cm), wound dressing no. 15, swab antiseptic, tweezers metal 8 cm, scissors disposable, safety pins assorted (12 pcs), hot and cold compress pack, first aid quick reference guide. | 1 | package | 2 |
| Plumbing NC II Tools and Equipment (for training purposes) | | | | | |
| 1 | Pipe Wrench | 12" straight, heavy duty, forged alloy steel 12", pipe capacity 2" or 50mm, weight 1.2 kg. cast-iron housing and I-beam handle with full floating forged hook jaw, featuring self cleaning threads with replaceable hook and heel jaws | 5 | pc | 3 |

T
N
A
P

Procurement of CMU Boxes, Tools and Equipment and Mock-ups for the Mobile Training Laboratories (MTLs).

TESDA Sarangani Provincial Office

Door 5-7, 2nd Floor One Roma Square Aparante Ave. City Heights, General Santos City

| NO. | ITEM | AGENCY SPECS | QTY | UNIT | No. Of Box |
|-----|-------------------------------|--|-----|------|------------|
| 2 | Pipe Wrench | 14" straight, heavy duty, forged alloy steel 12", pipe capacity 2" or 50mm, weight 1.6 kg. cast-iron housing and I-beam handle with full floating forged hook jaw, featuring self cleaning threads with replaceable hook and heel jaws | 5 | pc | 3 |
| 3 | Pull Push Rule | blade length 8 mtrs, blade width 1", high impact ABS case with durable rubber corrosion resistant tru-zero end | 10 | pc | 3 |
| 4 | Hacksaw | adjustable hacksaw frame with bi-metal hacksaw blade, 24 TPI, aluminum alloy frame and handle | 5 | pc | 3 |
| 5 | Spirit Level | high impact plastic; magnetic; 3 vials; Length:24" | 5 | pc | 3 |
| 6 | Pipe Reamer | 2 " capacity, ratchet type with steel handle, 1/8-2 " capacity, suitable for use with power drives | 5 | pc | 3 |
| 7 | Pipe Cutter | max. capacity 1/8-2 " for steel or ductile iron pipes with steel handle | 5 | pc | 3 |
| 8 | Adjustable Wrench | alloy steel, 0 - 2 " jaw opening, 10" length | 5 | pc | 3 |
| 9 | Mechanical Plier | mechanical, plastic dipped insulated handle, 6 " length, rust-resistant chrome finish, two position adjustable joint pliers | 5 | pc | 3 |
| 10 | Pipe Vise | capacity 2", material steel, d with swivel base with dual locking nuts, 360 degrees of rotation. | 2 | pc | 3 |
| 11 | Pipe Threader | drop head with 3 sets of head and dies, sizes (1/2", 3/4", 1") | 2 | pc | 3 |
| 12 | Portable Tri-stand Chain Vise | 1/8 to 6 in., rear pipe support, rugged tool tray capacity: 1/8" - 6", leg locking: over center tool tray | 3 | pc | 3 |
| 13 | Manual Pressure Test Pump | 6 mpa, 860 psi max. pressure, 12 L. capacity, with brass pump valve | 1 | pc | 3 |
| 14 | Socket Fusion Machine | 20 mm - 32 mm cap, 3/4", 1", 1-1/4" and 1-1/2", 220V, 1600w | 2 | pc | 3 |
| 15 | Ballpeen hammer | 12 oz., 11 1/2" overall length forged steel construction, hardened and tempered, wooden handle | 5 | pc | 3 |
| 16 | Angle Grinder | 4 "diameter, wheel cap, 220V, 60 Hz, single phase, 11,000 rpm, all-ball bearing design and metal gear | 2 | pc | 3 |
| 17 | Electric Portable Drill | 1/2 " bit jaw capacity, 220V, single phase, variable speed (0-550 rpm), heavy duty, 1/2" drill chuck | 1 | pc | 3 |
| 18 | Carpenter Steel Square | high tempered aluminum steel, 2" x 16" x 24", 5-60 and 30-degree angle markings, high tempered aluminum for maximum durability, 1/8-inch graduations for long-term visibility, body: 24 by 2-inches, tongue: 16 by 1-1/2" | 4 | pc | 3 |
| 19 | Claw Hammer | 16 oz., forged steel construction, hardened and tempered steel head, smooth face, wooden handle | 5 | pc | 3 |
| 20 | Paint Brush | 1/2" round trim brush soft bristle, tin-plated ferrules | 10 | pc | 3 |
| 21 | Hand Gloves | 5 finger, poly/cotton blend with a latex coated palm | 25 | pc | 3 |
| 22 | Safety Hard Hat | V-rib, yellow ball-cap style hard hat with 6 point ratchet-type headgear, 2 point chin strap and V rib on top, polyethylene material | 25 | pc | 3 |
| 23 | Safety Shoes | heavy duty steel toe cap, waterproof, anti static (sizes 40-42) Its anti-static and heat resistant (up to 300 degree C/572 degree F) with TPU SAFETY cell construction steel toe cap | 25 | pc | 3 |

Handwritten signature/initials

Procurement of CMU Boxes, Tools and Equipment and Mock-ups for the Mobile Training Laboratories (MTLs).

TESDA Sarangani Provincial Office

Door 5-7, 2nd Floor One Roma Square Aparante Ave. City Heights, General Santos City

| NO. | ITEM | AGENCY SPECS | QTY | UNIT | No. Of Box |
|--|---------------------------|--|-----|---------|------------|
| 24 | Safety Goggles | clear polycarbonate, woven elastic strap (adjustable) | 25 | pc | 3 |
| 25 | Water Meter | multi jet plastic meter, 1/2" NPT, 20 gpm, brass body | 1 | pc | 3 |
| 26 | Water Closet | flush type, ceramic, dimension (LxWxH): 684x430x787 mm, flushing action: siphonic, single/dual flush: single flush, flush Volume: 6L, flushing activation: front lever, rough-in: 305mm, discharge: floor cover | 1 | pc | 3 |
| 27 | Lavatory with Faucet | center hole, with mixing hot and cold faucet, ceramic, wall hung type, wall hung sink, 4-inch center faucet holes, front overflow, self-draining deck area with contoured back and side splash shields | 2 | pc | 3 |
| 28 | Kitchen Sink with Faucet | stainless steel, rust and heat resistant, grade 304, 74 cm x 51.5 cm, 16.2 mm outlet hole | 1 | pc | 3 |
| 29 | Single Point Water Heater | 4.5kw, 220V, 60 Hz, 2 psi min water pressure, 55 psi, 2 L/min minimum water flow, 1/2" BSP | 2 | pc | 3 |
| 30 | Laptop | 15.6", Core i7, 1.40GHz, wide screen, 1TB hard drive, 8GB DDR3 memory, NVIDIA GTX 670MX graphic processor, 3GB video memory, Gigabit 10/100/1000Mbps IEEE802.11b/g/n Wireless LAN, web camera, HDMI, Bluetooth, USB2.0, USB3.0, with Windows 8 OS, up to 6 hours charge-in-use battery, DVDRW super Multi with 1 year warranty | 1 | unit | 3 |
| 31 | MS Office 2013 | Home & Student 1 user | 1 | unit | 3 |
| 32 | Projector | LCD Projector Portable, RGB liquid crystal shutter projection system (3LCD), White Light Output 2,600 lumens, Colour Light Output 2,600 lumens, XGA Resolution, lightweight: less than 2 kgs. | 1 | unit | 3 |
| 33 | HDMI cable | 3 meters, v1.4A HDMI cable for Projector | 1 | pc | 3 |
| 34 | Whiteboard | wooden whiteboard (2' x 3') with frame, 1 meter collapsible high stand | 1 | pc | 3 |
| 35 | PA System | 550W Portable with Trolley, with 2 wireless mics, 220V, RCA port, with warranty | 1 | unit | 3 |
| 36 | Megaphone | with speak and music switch and volume control, 25w | 1 | unit | 3 |
| 37 | First Aid Kit | First Aid Kit with the contents: betadine, alcohol, adhesive strips, band-aid, disposable gloves, hypoallergenic medical tape (1.25 cm x 9.1m), conforming bandage (5cm), triangular bandage (110m x 110cm), wound dressing no. 15, swab antiseptic, tweezers metal 8 cm, scissors disposable, safety pins assorted (12 pcs), hot and cold compress pack, first aid quick reference guide. | 1 | package | 3 |
| Small Engine Repair (Motorcycle/Small Engine Servicing NC II) Tools and Equipment (for training purposes) | | | | | |
| 1 | Impact Drive Tool | 4pcs, 1/2" Impact Driver Set, heavy duty. | 10 | set | 4 |

Handwritten marks and signatures in the bottom right corner.

Procurement of CMU Boxes, Tools and Equipment and Mock-ups for the Mobile Training Laboratories (MTLs).

TESDA Sarangani Provincial Office

Door 5-7, 2nd Floor One Roma Square Aparante Ave. City Heights, General Santos City

| NO. | ITEM | AGENCY SPECS | QTY | UNIT | No. Of Box |
|-----|----------------------------|--|-----|------|------------|
| 2 | Multi-Tester | analog, standard-size analog multimeter for measuring voltage, current, and resistance. An auxiliary connector is also provided for checking transistors. Specifications: •DC Voltage Range: 0 to 1000V in seven ranges •AC Voltage Range: 0 to 1000V in five ranges •DC Current Range: 0 to 250mA in four ranges •Resistance Range: x1 to 20KW in four ranges •Transistor hFE Range: -0 to 1000 •Transistors Leakage Current (ICEO) Range: -0 to 150mAAF Output Range: -10dB to +22dB | 10 | pc | 4 |
| 3 | Oiler | metal case, 1/2 liter cap | 10 | pc | 4 |
| 4 | Steel Brush | wooden handle | 10 | pc | 4 |
| 5 | Hacksaw | adjustable hacksaw frame with bi-metal hacksaw blade, 24 TPI, aluminum alloy frame and handle | 10 | pc | 4 |
| 6 | Center Punch | high speed steel, 5x125 mm | 10 | pc | 4 |
| 7 | Cold Chisel | flat blade, 1" (W), 6" (L), hardened steel | 10 | pc | 4 |
| 8 | Fly Wheel/Magneto Puller | universal type, six in one fly wheel/ magneto puller | 10 | pc | 4 |
| 9 | Oil Seal Remover/Installer | pointed tip, hardened steel w/ straight handle, 3 pcs per set | 10 | set | 4 |
| 10 | Piston Ring Compressor | self locking w/ L wrench steel, range 2 1/8" to 5 inch diameter | 10 | pc | 4 |
| 11 | Valve Spring Compressor | spring loaded offset jaw overhead valve spring compressor, steel | 10 | pc | 4 |
| 12 | Clutch Assembly Remover | universal compressor clutch hub for removal and installation | 10 | pc | 4 |
| 13 | Electricians Plier | overall length 6, knife length: 5/8", material: carbon steel handle finished: plastic dipped | 10 | pc | 4 |
| 14 | Diagonal Cutting Plier | dyna grip, 152mm/6" inches carbon steel | 10 | pc | 4 |
| 15 | Mechanical Plier | 8", insulated handle | 10 | pc | 4 |
| 16 | Vise Gripped Plier | 10R straight jaw | 10 | pc | 4 |
| 17 | Feeler Gauge | 26 blade feeler gauge set, metric & English marked gauge | 10 | pc | 4 |
| 18 | Screwdriver, Flat | 8", magnetic tip, chrome vanadium, plastic handle | 10 | pc | 4 |
| 19 | Screwdriver, Philips | 8", magnetic tip, chrome vanadium, plastic handle | 10 | pc | 4 |
| 20 | Ballpeen hammer | 12 oz. 11 1/2" overall length forged steel construction, hardened and tempered, wooden handle | 10 | pc | 4 |
| 21 | Hammer, Brass/copper | 1 lb., wooden handle | 10 | pc | 4 |
| 22 | Hammer, Plastic | 1 lb, wooden handle, plastic tip hammer | 10 | pc | 4 |
| 23 | Wrench, Sparkplug | 19x16 mm, hexagonal w/ handle | 10 | pc | 4 |
| 24 | Wrench, Combination | 6mm,8mm,10mm,11mm,12mm,13mm,14mm,15mm, 16mm,17mm,19mm, 21mm,22mm, 24 mm, chrome vanadium steel | 10 | set | 4 |
| 25 | Wrench, Socket | 8 - 32 mm., black, 1/2" drive | 10 | set | 4 |
| 26 | Wrench, T-type | 8, 10, 12, 14 mm | 10 | set | 4 |
| 27 | Hand Tractor Engine | diesel engine, single piston, 4 stroke direct injection, 10-12 hp | 2 | unit | 4 |

T
2
of
9

Procurement of CMU Boxes, Tools and Equipment and Mock-ups for the Mobile Training Laboratories (MTLs).

TESDA Sarangani Provincial Office

Door 5-7, 2nd Floor One Roma Square Aparante Ave. City Heights, General Santos City

| NO. | ITEM | AGENCY SPECS | QTY | UNIT | No. Of Box |
|-----|----------------|--|-----|---------|------------|
| 28 | Laptop | 15.6", Core i7, 1.40GHz, wide screen, 1TB hard drive, 8GB DDR3 memory, NVIDIA GTX 670MX graphic processor, 3GB video memory, Gigabit 10/100/1000Mbps IEEE802.11b/g/n Wireless LAN, web camera, HDMI, Bluetooth, USB2.0, USB3.0, with Windows 8 OS, up to 6 hours charge-in-use battery, DVDRW super Multi with 1 year warranty | 1 | unit | 4 |
| 29 | MS Office 2013 | Home & Student 1 user | 1 | unit | 4 |
| 30 | Projector | LCD Projector Portable, RGB liquid crystal shutter projection system (3LCD), White Light Output 2,600 lumens, Colour Light Output 2,600 lumens, XGA Resolution, lightweight: less than 2 kgs. | 1 | unit | 4 |
| 31 | HDMI cable | 3 meters, v1.4A HDMI cable for Projector | 1 | pc | 4 |
| 32 | Whiteboard | wooden whiteboard (2' x 3') with frame, 1 meter collapsible high stand | 1 | pc | 4 |
| 33 | PA System | 550W Portable with Trolley, with 2 wireless mics, 220V, RCA port, with warranty | 1 | unit | 4 |
| 34 | Megaphone | with speak and music switch and volume control, 25w | 1 | unit | 4 |
| 35 | First Aid Kit | First Aid Kit with the contents: betadine, alcohol, adhesive strips, band-aid, disposable gloves, hypoallergenic medical tape (1.25 cm x 9.1m), conforming bandage (5cm), triangular bandage (110m x 110cm), wound dressing no. 15, swab antiseptic, tweezers metal 8 cm, scissors disposable, safety pins assorted (12 pcs), hot and cold compress pack, first aid quick reference guide. | 1 | package | 4 |

Handwritten signature and initials in the bottom right corner of the page.

**Procurement of CMU Boxes, Tools and Equipment and Mock-ups for
the Mobile Training Laboratories (MTLs).**

**TESDA Sarangani Provincial Office
Door 5-7, 2nd Floor One Roma Square Aparante Ave. City Heights,
General Santos City**

| Lot No. | Item / Description | Qty. | Unit | No. of Mock-up |
|--|---|------|-------|----------------|
| Electrical Installation and Maintenance (EIM) NC II Mock-up | | | | |
| 1 | Electrical Installation Maintenance (EIM) Mock-Up | 1 | lot | 1 |
| SUPPLIES AND MATERIALS | | | | |
| 2 | Heat gun, 1200 watts | 1 | pc | 1 |
| 3 | PVC adapter with lock nuts | 20 | pc | 1 |
| 4 | Circuit breaker, 30A | 2 | pc | 1 |
| 5 | 1/2" diameter PVC pipe | 2 | meter | 1 |
| 6 | Cable ties, 100 pcs./pack | 1 | pack | 1 |
| 7 | Incandescent bulb, 220V, 25W | 5 | pc | 1 |
| 8 | One pole switch with plate, flush type | 5 | pc | 1 |
| 9 | Three way switch with plate, flush type | 5 | pc | 1 |
| 10 | Four way switch with plate, flush type | 5 | pc | 1 |
| 11 | Lamp receptacle 4" X 4" surface type | 5 | pc | 1 |
| 12 | Photo electrical (photocell) | 1 | pc | 1 |
| 13 | Convenience outlet, universal type | 5 | pc | 1 |
| 14 | Floor outlet, round type | 1 | pc | 1 |
| 15 | Ground fault current interrupter | 1 | pc | 1 |
| 16 | Circuit breaker 60A with built in housing | 1 | pc | 1 |
| 17 | Terminal block 15A 12 slots | 40 | pc | 1 |
| 18 | Automotive Wire #14 AWG (1 solid and 1 stranded) | 2 | roll | 1 |
| 19 | Terminal lug, Y type | 150 | pc | 1 |
| This include supplies and materials required in the fabrication of mock-up | | | | |
| Plumbing NC II Mock-up | | | | |
| 1 | Plumbing Mock-up (Labor Cost) | 1 | lot | 1 |
| SUPPLIES AND MATERIALS | | | | |
| 2 | 4" dia PVC Pipe (Orange) | 1 | pc | 1 |
| 3 | 4" dia. PVC Elbow 90 deg. | 1 | pc | 1 |
| 4 | 4" dia. PVC Elbow 45 deg. | 1 | pc | 1 |
| 5 | 4" dia. PVC Clean Out | 1 | pc | 1 |
| 6 | 4" x 3" PVC Wye | 1 | pc | 1 |
| 7 | 4" x 2" PVC Wye | 3 | pc | 1 |
| 8 | 3" dia. PVC pipe | 1 | pc | 1 |
| 9 | 3" PVC Elbow | 1 | pc | 1 |
| 10 | 3" PVC Elbow 45 deg. | 1 | pc | 1 |
| 11 | 3" x 2" PVC Tee | 1 | pc | 1 |
| 12 | 3" x 3" PVC Tee | 1 | pc | 1 |
| 13 | 2" dia PVC Pipe | 2 | pc | 1 |
| 14 | 2" dia. PVC Elbow 45 deg. | 3 | pc | 1 |
| 15 | 2" dia. PVC Elbow 90 deg. | 3 | pc | 1 |
| 16 | 2" PVC Tee | 4 | pc | 1 |
| 17 | 2" PVC P-trap | 2 | pc | 1 |
| 18 | 1/2" dia. PPr pipe | 2 | pc | 1 |
| 19 | 1/2" dia. PPr elbow | 7 | pc | 1 |
| 20 | 1/2" dia. PPr tee | 4 | pc | 1 |
| 21 | 1/2" dia. PPr elbow connector | 6 | pc | 1 |
| 22 | 1/2" dia. PPr male connector | 2 | pc | 1 |
| 23 | 1/2" dia. PPr union | 3 | pc | 1 |
| 24 | 1/2" dia. PPr coupling | 4 | pc | 1 |

7 W
of 96

**Procurement of CMU Boxes, Tools and Equipment and Mock-ups for
the Mobile Training Laboratories (MTLs).**

**TESDA Sarangani Provincial Office
Door 5-7, 2nd Floor One Roma Square Aparante Ave. City Heights,
General Santos City**

| Lot No. | Item / Description | Qty. | Unit | No. of Mock-up |
|--|--|------|-------|----------------|
| 25 | Urinal 480mm X 730mm X 730mm with complete accessories | 1 | unit | 1 |
| 26 | Shower head with complete accessories | 1 | unit | 1 |
| 27 | 1/2 x 7/8 flexible hose | 1 | pc | 1 |
| 28 | 1/2 x 1/2" angle valve | 3 | pc | 1 |
| 29 | 3/4" x 4' x 8' Marine Plywood | 1 | pc | 1 |
| 30 | 2" x 2" x 12' Lumber | 4 | pc | 1 |
| 31 | Teflon Tape | 10 | pc | 1 |
| 32 | Metal hinges 2" X 4", heavy duty | 3 | pc | 1 |
| This include supplies and materials required in the fabrication of mock-up | | | | |
| Small Engine Repair (Motorcycle/Small Engine Servicing NC II) Tools and Equipment Mock-up | | | | |
| 1 | Motorcycle/Small Engine Collapsible Mock-Up | 1 | lot | 1 |
| SUPPLIES AND MATERIALS: | | | | |
| 2 | Auto wire, stranded # 16 | 1 | roll | 1 |
| 3 | Electrical tape, large black | 2 | pc | 1 |
| 4 | Head light assembly, 12 volts rectangular | 1 | pc | 1 |
| 5 | signal light assembly, 12 volts | 2 | pair | 1 |
| 6 | Horn, 12 volts | 1 | pc | 1 |
| 7 | Stop light switch, push button | 1 | pc | 1 |
| 8 | Signal light switch, double throw, toggle switch | 1 | pc | 1 |
| 9 | Ignition switch, gas engine type | 1 | pc | 1 |
| 10 | Signal light relay, 12 volts | 1 | pc | 1 |
| 11 | Push button switch for horn | 1 | pc | 1 |
| 12 | Motorcycle storage battery, 12 volts maintenance free | 1 | pc | 1 |
| 13 | Harness cover, 3/8" diameter (140/4) | 4 | meter | 1 |
| 14 | Harness connector, 6 terminals | 4 | pc | 1 |
| 15 | Male terminal, flat | 30 | pc | 1 |
| 16 | Female terminal, flat | 30 | pc | 1 |
| 17 | Headlight switch or toggle switch, single throw | 1 | pc | 1 |
| 18 | Crocodile clip, medium, red and black | 1 | pair | 1 |
| 19 | 3/16" diameter X 3/4" stove bolt, stainless | 20 | pc | 1 |
| 20 | 3/16" diameter hole, eye terminal | 10 | pc | 1 |
| 21 | Four stroke motorcycle engine, 125 or 155cc, surplus | 1 | unit | 1 |
| This include supplies and materials required in the fabrication of mock-up | | | | |

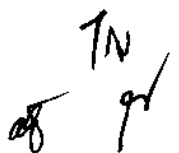

Procurement of CMU Boxes, Tools and Equipment and Mock-ups for the Mobile Training Laboratories (MTLs).

**TESDA Lanao Del Sur Provincial Office
3rd Floor, Line Agencies Bldg., New Provincial Capitol, Compound Marawi City**

| NO. | ITEM | AGENCY SPECS | QTY | UNIT | No. Of Box |
|---|--|---|-----|------|------------|
| Appliance Repair NC II Tools and Equipment (for training purposes) | | | | | |
| 1 | Soldering Iron | dual wattage, 25 watts/ 120watts, 220 volt 60 Hz, with long life tip, "gun type" | 25 | unit | 3 |
| 2 | Desoldering Tools | desoldering pump with precision regulated return, replacement tip compact, metal housing | 25 | unit | 3 |
| 3 | Screw driver assorted (Phillips and slotted) | 12x7x1 inches, 6 pieces per set, plastic handle | 5 | set | 3 |
| 4 | Long Nose Plier | dyna grip, 152mm/6" inches carbon steel | 5 | pc | 3 |
| 5 | Diagonal Cutting Plier | dyna grip, 152mm/6" inches carbon steel | 5 | pc | 3 |
| 6 | Nut Drivers | rust-resistant, nickel-plated bar, hexagonal shank, includes: 5mm, 6mm, 7mm, 8mm, 9mm, 10mm, 11mm | 5 | set | 3 |
| 7 | Wrench, Combination | 6mm,8mm,10mm,11mm,12mm,13mm,14mm,15mm, 16mm,17mm,19mm, 21mm,22mm, 24 mm, chrome vanadium steel | 5 | set | 3 |
| 8 | Wire Stripper | automatic, cap. 1.5mm to 3.5mm | 10 | pc | 3 |
| 9 | Ballpeen hammer | 12 oz., 11 1/2" overall length forged steel construction, hardened and tempered, wooden handle | 5 | pc | 3 |
| 10 | Flashlight | LED, 3 volts/6 volts, rechargeable | 5 | pc | 3 |
| 11 | Detector Light | test light, 220 volts | 5 | pc | 3 |
| 12 | Paint Brush | 4 inches width, wooden handle | 25 | pc | 3 |
| 13 | Microwave Oven | power capacity: 220V 1300 watts, interior capacity 20 liters, 8 programmes, defrost option, 26cm diameter rotating turntable, digital | 1 | unit | 3 |
| 14 | Washing Machine with dryer | power capacity: 500w, 220V, rust proof body, gear drive system, dolphin drive pulsator, washing capacity (dry weight) 7.5kg, spinning capacity (dry weight) 5.5kg, width should be more than 50 cm and length of not more than 100 cm | 1 | unit | 3 |
| 15 | Electric Fan | power capacity: 220V, 100w, 60Hz, 3 speed rotary switch, 18 inch metal blade, round/stable plastic base, thermal fuse protection, adjustable height stand fan | 1 | unit | 3 |
| 16 | Electric Rice Cooker | power capacity: 700w, 220V, 60Hz, automatic cooking feature, auto shutoff, glass lid, non-stick coated aluminum pan, includes measuring cup and rice scoop | 1 | unit | 3 |

Handwritten signature/initials

Procurement of CMU Boxes, Tools and Equipment and Mock-ups for the Mobile Training Laboratories (MTLs).

**TESDA Lanao Del Sur Provincial Office
3rd Floor, Line Agencies Bldg., New Provincial Capitol, Compound Marawi City**

| NO. | ITEM | AGENCY SPECS | QTY | UNIT | No. Of Box |
|-----|--------------------|---|-----|------|------------|
| 17 | Electric Flat Iron | power capacity:1000w, 220V, 60 Hz, non-stick Teflon soleplate, thermal fuse protected, variable temperature control, automatic thermostat Control, pilot lamp indicator | 1 | unit | 3 |
| 18 | Coffee Maker | power capacity: 550w, 220V, 60Hz, glass pitcher, anti-drip feature, 6 cup water capacity, water level indicator, swing-out filter basket | 1 | unit | 3 |
| 19 | Oven Toaster | power capacity: 1000w, 220V, 60Hz, stainless steel, 8 liter capacity, 15 minute timer, slide out chrome crumb rack, includes baking tray | 1 | unit | 3 |
| 20 | Blender | 1.5 liter capacity, rated voltage, 230V, 60Hz, power consumption: 300 watts, sharp stainless steel blade, safety lock switch, with plastic stirrer for easy mixing | 1 | unit | 3 |
| 21 | Multi Tester | analog, standard size analog multimeter for measuring voltage, current and resistance. An auxiliary connector is also provided for checking transistors. SPECIFICATION: •DC Voltage Range: 0 to 1000V in seven ranges •AC Voltage Range: 0 to 1000V in five ranges •DC Current Range: 0 to 250mA in four ranges •Resistance Range: x1 to 200MEG in four ranges •Transistor hFE Range: -0 to 1000 •Transistors Leakage Current (ICEO) Range: -0 to 150mAAF Output Range: -10dB to +22dB | 25 | unit | 3 |
| 22 | Multi Tester | Digital Multi meters are standard digital multimeter for measuring voltage, current, and resistance with 3-1/2 digit LCD display. This meter measures only 138mm x 70mm x 32mm and weighs approximately 140 grams, including battery. SPECIFICATION: •DC Voltage Range: 200mV to 600V in five ranges (auto ranging) •AC Voltage Range: 2V to 600V in four ranges (auto ranging) •DC Current Range: 200mA to 10A in six ranges •Resistance Range: 200 Ohms to 20M in six ranges Transistor hFE Test Range: 0 to 2000 | 25 | unit | 3 |
| 23 | Laptop | 15.6", Core i7, 1.40GHz, wide screen, 1TB hard drive, 8GB DDR3 memory, NVIDIA GTX 670MX graphic processor, 3GB video memory, Gigabit 10/100/1000Mbps IEEE802.11b/g/n Wireless LAN, web camera, HDMI, Bluetooth, USB2.0, USB3.0, with Windows 8 OS, up to 6 hours charge-in-use battery, DVDRW super Multi with 1 year warranty | 1 | unit | 3 |
| 24 | MS Office 2013 | Home & Student 1 user | 1 | unit | 3 |

Procurement of CMU Boxes, Tools and Equipment and Mock-ups for the Mobile Training Laboratories (MTLs).

**TESDA Lanao Del Sur Provincial Office
3rd Floor, Line Agencies Bldg., New Provincial Capitol, Compound Marawi City**

| NO. | ITEM | AGENCY SPECS | QTY | UNIT | No. Of Box |
|---|-----------------------|--|-----|---------|------------|
| 25 | Projector | LCD Projector Portable, RGB liquid crystal shutter projection system (3LCD), White Light Output 2,600 lumens, Colour Light Output 2,600 lumens, XGA Resolution, lightweight: less than 2 kgs. | 1 | unit | 3 |
| 26 | HDMI cable | 3 meters, v1.4A HDMI cable for Projector | 1 | pc | 3 |
| 27 | Whiteboard | wooden whiteboard (2' x 3') with frame, 1 meter collapsible high stand | 1 | pc | 3 |
| 28 | PA System | 550W Portable with Trolley, with 2 wireless mics, 220V, RCA port, with warranty | 1 | unit | 3 |
| 29 | Megaphone | with speak and music switch and volume control, 25w | 1 | unit | 3 |
| 30 | First Aid Kit | First Aid Kit with the contents: betadine, alcohol, adhesive strips, band-aid, disposable gloves, hypoallergenic medical tape (1.25 cm x 9.1m), conforming bandage (5cm), triangular bandage (110m x 110cm), wound dressing no. 15, swab antiseptic, tweezers metal 8 cm, scissors disposable, safety pins assorted (12 pcs), hot and cold compress pack, first aid quick reference guide. | 1 | package | 3 |
| Bread and Pastry NC II Tools and Equipment (for training purposes) | | | | | |
| 1 | Measuring Cup, dry | stainless steel, 4 pcs/set (1c, 1/2c, 1/3c & 1/4c) | 12 | pc | 3 |
| 2 | Measuring Cup, liquid | glass graduated, 250 ml capacity | 12 | pc | 3 |
| 3 | Measuring Spoon | Stainless steel 6 pcs/set(1/8 tsp, 1/4 tsp, 1/2tsp, 1 tsp 1/2 (bsp), 1 (bsp)) | 12 | set | 3 |
| 4 | Cake Turn Table | plastic cake turntable with locking switch, rubberized feet, white, 12.6x12.6x3.54 inches (LxWxH) | 10 | pc | 3 |
| 5 | Decorating Tips | stainless steel, 24-piece cake decorating tip set, package size: 17cm x 12cm x 5cm (6.69 x 4.72 x 1.97inches) | 25 | set | 3 |
| 6 | Rolling Pin | wooden, size 33.5 x 5cm, light weight comfortable grip | 25 | pc | 3 |
| 7 | Pie Plate, size 6" | aluminum pie pan, 6" diameter x 5/8 in deep, heavy weight round pan | 10 | pc | 3 |
| 8 | Pie Plate, size 8" | pie pan, 8" aluminum deep dish pie pan, standard weight aluminum, 8" top outside diameter | 10 | pc | 3 |
| 9 | Pie Plate, size 10" | deep aluminum pie pan, 10" diameter, depth 1-1/4", made of 0.7mm thick satin finished aluminum | 10 | pc | 3 |
| 10 | Jelly Roll Pan | aluminum, dimension: 2" x 13 x 8" (HxWxD) | 10 | pc | 3 |
| 11 | Cake Spring Form Pan | heavy aluminum spring form pan, heavy duty frame, spring form sides for easy removal, size 9 x 3" | 10 | pc | 3 |

TN
pb
abg

Procurement of CMU Boxes, Tools and Equipment and Mock-ups for the Mobile Training Laboratories (MTLs).

**TESDA Lanao Del Sur Provincial Office
3rd Floor, Line Agencies Bldg., New Provincial Capitol, Compound Marawi City**

| NO. | ITEM | AGENCY SPECS | QTY | UNIT | No. Of Box |
|-----|----------------------|--|-----|------|------------|
| 12 | Pie Cutter | triple riveted pizza cutter, made of stainless steel, rolling wheel slicer, 6" | 10 | pc | 3 |
| 13 | Rubber Scraper | rubber head, high heat resistant, flexible, 12", color white | 25 | pc | 3 |
| 14 | Spatula | Stainless steel straight blade, 14 inches long with wood handle | 25 | pc | 3 |
| 15 | Cake Stand with tier | 3 tier cake round acrylic cake stand, 3 plates clear, size: 15cm, 20cm, 25cm, 10 inches gap between each tier | 6 | set | 3 |
| 16 | Saucepan | Stainless steel with cover and handle 26cm | 15 | pc | 3 |
| 17 | Ladle | stainless steel, 12 inches, comes with brush finished handle, hole in the handle for easy hanging | 10 | pc | 3 |
| 18 | Chef Knife | 8 inch, stainless steel full tang blade with plastic handle | 12 | pc | 3 |
| 19 | Chopping Board | 12 x 17 inches, polyethylene, easy grip handle, white color | 10 | pc | 3 |
| 20 | Weighing Scale | manual, maximum weight capacity 2kg, graduated by grams, removable and washable tray | 6 | pc | 3 |
| 21 | Grater | made of nonreactive stainless steel easy grip handle | 10 | pc | 3 |
| 22 | Wooden Spoon | wooden turner, size 12 inches | 25 | pc | 3 |
| 23 | Piping Bag | 12 inches, light weight, reusable, flexible polyester, coated can be boiled, dishwasher safe | 25 | pc | 3 |
| 24 | Mixing Bowl | 12 inches diameter, 8-9 quarts capacity, stainless | 15 | pc | 3 |
| 25 | Wire Whisk | 8"/20cm, aluminum, balloon style | 25 | pc | 3 |
| 26 | Electric Mixer | 4 qt. stainless steel bowl, 5 speeds & quick burst button, bowl rest TM mixer stabilizer, doubles as a hand mixer, 220V, 290-watts peak power, versatile attachment set includes traditional beaters, whisk and dough hooks, brushed stainless steel | 5 | unit | 3 |
| 27 | Dough Cutter | dough scraper 6" wide x 4", high polished stainless steel blade | 10 | pc | 3 |
| 28 | Oven (gas) | stainless door, 2 trays oven with tempered glass window, 22-25" collapsible stand | 1 | unit | 3 |
| 29 | Pastry Brush | pastry/basting brush, natural wood handle brushes, 1.5" size | 10 | pc | 3 |
| 30 | Bread Knife | 8", serrated edge stain free high-carbon steel blade texture red polypropylene handle | 10 | pc | 3 |
| 31 | Flour Sifter | stainless steel mesh flour sifter strainer, 12" | 10 | pc | 3 |
| 32 | Baking Sheet | aluminum, 13" x 18" | 15 | pc | 3 |
| 33 | Muffin Pans | 12 holes, 3 oz. capacity per holes, aluminum | 25 | pc | 3 |

TN
A

Procurement of CMU Boxes, Tools and Equipment and Mock-ups for the Mobile Training Laboratories (MTLs).

**TESDA Lanao Del Sur Provincial Office
3rd Floor, Line Agencies Bldg., New Provincial Capitol, Compound Marawi City**

| NO. | ITEM | AGENCY SPECS | QTY | UNIT | No. Of Box |
|--|---------------------|--|-----|---------|------------|
| 34 | Working Table | high quality stainless steel foldable tables dimension: 3ft x 3ft | 4 | pc | 3 |
| 35 | Gas Stove with tank | 2 burner, made from stainless top body, automatic ignition, with complete accessories | 2 | pc | 3 |
| 36 | Kitchen Sink | Kitchen sink, portable single bowl sink stainless steel, with steel collapsible frame legs, with drain hose, Dimension 50cmx50cmx30cm | 1 | pc | 3 |
| 37 | Weighing Scale | digital, 1000g, maximum weight capacity, battery operated (AAA battery) 0.1 g to 1000g , LCD display battery included. | 5 | pc | 3 |
| 38 | Laptop | 15.6", Core i7, 1.40GHz, wide screen, 1TB hard drive, 8GB DDR3 memory, NVIDIA GTX 670MX graphic processor, 3GB video memory, Gigabit 10/100/1000Mbps IEEE802.11b/g/n Wireless LAN, web camera, HDMI, Bluetooth, USB2.0, USB3.0, with Windows 8 OS, up to 6 hours charge-in-use battery, DVDRW super Multi with 1 year warranty | 1 | unit | 3 |
| 39 | MS Office 2013 | Home & Student 1 user | 1 | unit | 3 |
| 40 | Projector | LCD Projector Portable, RGB liquid crystal shutter projection system (3LCD), White Light Output 2,600 lumens, Colour Light Output 2,600 lumens, XGA Resolution, lightweight: less than 2 kgs. | 1 | unit | 3 |
| 41 | HDMI cable | 3 meters, v1.4A HDMI cable for Projector | 1 | pc | 3 |
| 42 | Whiteboard | wooden whiteboard (2' x 3') with frame, 1 meter collapsible high stand | 1 | pc | 3 |
| 43 | PA System | 550W Portable with Trolley, with 2 wireless mics, 220V, RCA port, with warranty | 1 | unit | 3 |
| 44 | Megaphone | with speak and music switch and volume control, 25w | 1 | unit | 3 |
| 45 | First Aid Kit | First Aid Kit with the contents: betadine, alcohol, adhesive strips, band-aid, disposable gloves, hypoallergenic medical tape (1.25 cm x 9.1m), conforming bandage (5cm), triangular bandage (110m x 110cm), wound dressing no. 15, swab antiseptic, tweezers metal 8 cm, scissors disposable, safety pins assorted (12 pcs), hot and cold compress pack, first aid quick reference guide. | 1 | package | 3 |
| Cookery NC II Tools and Equipment (for training purposes) | | | | | |
| 1 | Chef Knife | 8 inch, stainless steel full tang blade with plastic handle | 10 | pc | 3 |
| 2 | Boning Knife | 6 inches, stainless steel with sharp cutting edge with plastic handle | 8 | pc | 3 |
| 3 | Oyster Knife | 7 inches length (3 inches blade and 4 inches handle), stainless steel blade, with comfortable plastic handle | 4 | pc | 3 |

TN
pd
ag

Procurement of CMU Boxes, Tools and Equipment and Mock-ups for the Mobile Training Laboratories (MTLs).

**TESDA Lanao Del Sur Provincial Office
3rd Floor, Line Agencies Bldg., New Provincial Capitol, Compound Marawi City**

| NO. | ITEM | AGENCY SPECS | QTY | UNIT | No. Of Box |
|-----|--------------------------|--|-----|------|------------|
| 4 | Cleaver Knife | 7 inches, stain resistant carbon steel blade | 2 | pc | 3 |
| 5 | Tenderizer | with flat and textured side, non slip, 10 inches 25.5 cm, solid aluminum construction | 8 | pc | 3 |
| 6 | Skimmer | fine, extra fine mesh, 6 inches diameter, with stainless handle | 8 | pc | 3 |
| 7 | Wire Skimmer | small, nickel plated wire oil skimmer, 16 inches long overall, 5 inches diameter bowl | 8 | pc | 3 |
| 8 | Skimmer | spider, 5 inches diameter, natural bamboo handle, constructed of durable stainless steel with versatile woven design | 8 | pc | 3 |
| 9 | Strainer, small | fine, 6" diameter, with stainless handle | 8 | pc | 3 |
| 10 | Siever | small 12" diameter, stainless | 8 | pc | 3 |
| 11 | Strainer, medium | medium, fine stainless steel mesh, 9 inches diameter with stainless handle | 8 | pc | 3 |
| 12 | Turner | solid, stainless steel, with handy loop for hanging, 12 inches long | 8 | pc | 3 |
| 13 | Spatula | Stainless steel straight blade, 14 inches long with wood handle | 8 | pc | 3 |
| 14 | Wooden Spatula | large comfortable handle, 12 inches long, wooden | 8 | pc | 3 |
| 15 | Piping Bag | 12 inches, light weight, reusable, flexible polyester, coated, can be boiled, dishwasher safe | 8 | pc | 3 |
| 16 | Pastry Tubes | steel stainless, set of 24 pcs, different/assorted icing nozzles medium size, constructed of 18/8 quality stainless steel, comes in plastic storage box with lid | 8 | set | 3 |
| 17 | Strainer, chinois medium | medium, 8 inches diameter, stainless steel including handle | 3 | pc | 3 |
| 18 | Strainer, chinois small | small, 5 inches diameter, stainless steel including handle | 2 | pc | 3 |
| 19 | Funnel | general purpose, hard plastic, comes in 4 different sizes (small, medium, large, extra large) | 4 | set | 3 |
| 20 | Measuring Spoon | Stainless steel 6 pcs/set(1/8 tsp, 1/4 tsp, 1/2tsp, 1 tsp 1/2 tbsp, 1 tbsp) | 6 | set | 3 |
| 21 | Food Tong | 12 inches long, stainless steel, and wide shell head with locking | 8 | pc | 3 |
| 22 | Measuring Cup, liquid | glass graduated, 250 ml capacity | 8 | pc | 3 |
| 23 | Ice Cream Scooper | set of three, stainless steel (2 oz, 4 oz and 6 oz) | 2 | set | 3 |
| 24 | Cheese Cloth | 100% cotton 1 yard | 10 | pc | 3 |
| 25 | Serving Spoon | stainless steel, 9 inches long | 24 | pc | 3 |
| 26 | Pepper and Salt Mill | 2 in 1, wooden, 8" | 4 | pc | 3 |

7
2
20

Procurement of CMU Boxes, Tools and Equipment and Mock-ups for the Mobile Training Laboratories (MTLs).

**TESDA Lanao Del Sur Provincial Office
3rd Floor, Line Agencies Bldg., New Provincial Capitol, Compound Marawi City**

| NO. | ITEM | AGENCY SPECS | QTY | UNIT | No. Of Box |
|-----|------------------------|--|-----|------|------------|
| 27 | Weighing Scale | analog weighing scale ; maximum weight capacity , 5 kg, graduated by grams , removable and washable tray | 2 | unit | 3 |
| 28 | Weighing Scale | digital, 1000g, maximum weight capacity, battery operated (AAA battery) 0.1 g to 1000g , LCD display battery included. | 2 | unit | 3 |
| 29 | Apple Corer | corer head comfortable on slip handle, corer head is stainless steel | 4 | pc | 3 |
| 30 | Wire Whisk | 8"/20cm, aluminum, balloon style | 8 | pc | 3 |
| 31 | Wire Whisk, medium | medium, 10 inches/25 cm, aluminum, balloon style | 8 | pc | 3 |
| 32 | Wire Whisk, large | heavy duty, stainless steel, 14 inches, balloon style | 2 | pc | 3 |
| 33 | Measuring Cup, dry | stainless steel, 4 pcs/set (1c , 1/2c, 1/3c & 1/4c) | 1 | set | 3 |
| 34 | Chopping Board | 12 x17 inches, polyethylene, easy grip handle, white color | 10 | pc | 3 |
| 35 | Kitchen Scissors | stainless steel blade, size 2 cm x 12 cm x 27 cm, durable and sturdy handle with comfortable grip | 8 | pc | 3 |
| 36 | Soup Ladle | 3 oz capacity, stainless steel, with handle, round bottom | 8 | pc | 3 |
| 37 | Soup Ladle | 6 oz capacity, stainless steel handle, round bottom | 8 | pc | 3 |
| 38 | Soup Ladle | 8 oz capacity, stainless steel handle, round bottom | 3 | pc | 3 |
| 39 | Soup Ladle | 12 oz capacity, stainless handle, round bottom, | 2 | pc | 3 |
| 40 | Mixing Bowl | 12 inches diameter, 8-9 quarts capacity , stainless | 10 | pc | 3 |
| 41 | Kitchen Spoon | solid, stainless steel handle, comfortable non slip handle, round handle 4.5 x2.5 inches | 8 | pc | 3 |
| 42 | Kitchen Spoon | slotted, stainless steel, comfortable non slip handle, round handle 10 x 2.5 inches w/ hole | 8 | pc | 3 |
| 43 | Kitchen Fork | 7.5 cm x 4.5 cm x 37 cm or 10.5 inches, stainless steel, with 2 prongs, round handle | 8 | pc | 3 |
| 44 | Carving Fork | 10.5 inches, stainless steel, with 2 prongs, round handle | 3 | pc | 3 |
| 45 | Pocket Pin Thermometer | analog, temperature range from 0oF to 220 of, dial type | 3 | pc | 3 |
| 46 | Peeler | Straight blade type, dual stainless steel blade, metal handle 5",2"handle,3"blade | 8 | pc | 3 |
| 47 | Stockpot | stainless, 17 quarts capacity (22.7 lit), 12 inches diameter (30.5 cm), depth 31 cm, 4 mm thickness | 2 | pc | 3 |
| 48 | Frying pan | pan, large, non stick, 26 cm diameter | 2 | pc | 3 |

7
N
91
8

Procurement of CMU Boxes, Tools and Equipment and Mock-ups for the Mobile Training Laboratories (MTLs).

**TESDA Lanao Del Sur Provincial Office
3rd Floor, Line Agencies Bldg., New Provincial Capitol, Compound Marawi City**

| NO. | ITEM | AGENCY SPECS | QTY | UNIT | No. Of Box |
|-----|---------------------|--|-----|------|------------|
| 49 | Colander | medium, stainless steel, 8 quarts capacity, with base | 2 | pc | 3 |
| 50 | Fish Poacher | medium, 18 inches (L) and 6 inches(w), stainless steel, with handle | 1 | pc | 3 |
| 51 | Casserole | small, stainless steel, 20 cm diameter, with cover | 8 | pc | 3 |
| 52 | Casserole | medium, stainless steel, 24 cm diameter with cover | 4 | pc | 3 |
| 53 | Double Boiler | medium, made from stainless steel, 2 quarts capacity, with lid cover | 1 | pc | 3 |
| 54 | Paellara | 40 cm diameter, (50 cm with handle), constructed of carbon steel, riveted secure melt handle, safe for all heating surfaces including induction | 4 | pc | 3 |
| 55 | Baking Tray | small, main material is carbon, rectangular, size 14 x 10 inches | 8 | pc | 3 |
| 56 | Utility Tray | hard plastic tray, rectangular 14x18 inches | 12 | pc | 3 |
| 57 | Fire Extinguisher | cylinder type, multipurpose ABC dry chemical, powder aluminum valve coated, rechargeable, 5 lbs capacity, with pressure gauge that allows for immediate pressure status check, with wall hanger, meets requirements for underwriter laboratory (UJ) | 1 | unit | 3 |
| 58 | Blender | 1.5 liter capacity, rated voltage, 230V, 60Hz, power consumption: 300 watts, sharp stainless steel blade, safety lock switch, with plastic stirrer for easy mixing | 1 | unit | 3 |
| 59 | Pressure Cooker | aluminum, 2 mm, 6 quarts capacity, pressured handle, central pressure valve with self locking mechanism | 1 | pc | 3 |
| 60 | Gas Stove with tank | 2 burner, made from stainless top body, automatic ignition, with complete accessories | 4 | unit | 3 |
| 61 | Working Table | high quality stainless steel foldable tables dimension: 3ft x 3ft | 4 | pc | 3 |
| 62 | Kitchen Sink | Kitchen sink, portable single bowl sink stainless steel, with steel collapsible frame legs, with drain hose, Dimension 50cmx50cmx30cm | 1 | unit | 3 |
| 63 | Laptop | 15.6", Core i7, 1.40GHZ, wide screen, 1TB hard drive, 8GB DDR3 memory, NVIDIA GTX 670MX graphic processor, 3GB video memory, Gigabit 10/100/1000Mbps IEEE802.11b/g/n Wireless LAN, web camera, HDMI, Bluetooth, USB2.0, USB3.0, with Windows 8 OS, up to 6 hours charge-in-use battery, DVDRW super Multi with 1 year warranty | 1 | unit | 3 |
| 64 | MS Office 2013 | Home & Student 1 user | 1 | unit | 3 |
| 65 | Projector | LCD Projector Portable, RGB liquid crystal shutter projection system (3LCD), White Light Output 2,600 lumens, Colour Light Output 2,600 lumens, XGA Resolution, lightweight: less than 2 kgs. | 1 | unit | 3 |

7
2
96
8

Procurement of CMU Boxes, Tools and Equipment and Mock-ups for the Mobile Training Laboratories (MTLs).

**TESDA Lanao Del Sur Provincial Office
3rd Floor, Line Agencies Bldg., New Provincial Capitol, Compound Marawi City**

| NO. | ITEM | AGENCY SPECS | QTY | UNIT | No. Of Box |
|--|-----------------------|--|-----|---------|------------|
| 66 | HDMI cable | 3 meters, v1.4A HDMI cable for Projector | 1 | pc | 3 |
| 67 | Whiteboard | wooden whiteboard (2' x 3') with frame, 1 meter collapsible high stand | 1 | pc | 3 |
| 68 | PA System | 550W Portable with Trolley, with 2 wireless mics, 220V, RCA port, with warranty | 1 | unit | 3 |
| 69 | Megaphone | with speak and music switch and volume control, 25w | 1 | unit | 3 |
| 70 | First Aid Kit | First Aid Kit with the contents: betadine, alcohol, adhesive strips, band-aid, disposable gloves, hypoallergenic medical tape (1.25 cm x 9.1m), conforming bandage (5cm), triangular bandage (110m x 110cm), wound dressing no. 15, swab antiseptic, tweezers metal 8 cm, scissors disposable, safety pins assorted (12 pcs), hot and cold compress pack, first aid quick reference guide. | 1 | package | 3 |
| Electrical Installation and Maintenance NC II Tools and Equipment (for training purposes) | | | | | |
| 1 | Spirit Level | high impact plastic; magnetic; 3 vials; Length:24" | 1 | pc | 2 |
| | Hacksaw | adjustable hacksaw frame with bi-metal hacksaw blade, 24 TPI, aluminum alloy frame and handle | 5 | pc | 2 |
| 2 | Pipe Cutter | max. capacity 1/8-2 " for steel or ductile iron pipes with steel handle | 2 | pc | 2 |
| 3 | Pipe Reamer | 2 " capacity, ratchet type with steel handle, 1/8-2 " capacity, suitable for use with power drives | 2 | pc | 2 |
| 4 | Pipe Threader | drop head with 3 sets of head and dies, sizes (1/2", 3/4", 1") | 2 | unit | 2 |
| 5 | Pipe Bender | manual, 1/2-3/4 inch bending radius, ductile high strength iron | 2 | unit | 2 |
| 6 | Electricians Plier | overall length 6, knife length: 5/8", material: carbon steel handle finished: plastic dipped | 25 | pc | 2 |
| 7 | Long Nose Plier | dyna grip, 152mm/6" inches carbon steel | 25 | pc | 2 |
| 8 | Phillips Screw Driver | 1x75, PH 2 x 100, PH 2x125 plastic and rubberized handle chrome vanadium, shank 4" | 25 | set | 2 |
| 9 | Flat Screw Driver | 3x75, 5x100, 6x125 plastic and rubberized handle chrome vanadium shank 4" | 25 | set | 2 |
| 10 | Wrench, Combination | 6mm,8mm,10mm,11mm,12mm,13mm,14mm,15mm, 16mm,17mm,19mm, 21mm,22mm, 24 mm, chrome vanadium steel | 5 | set | 2 |
| 11 | Wire Stripper | automatic, cap. 1.5mm to 3.5mm | 10 | pc | 2 |
| 12 | Electrician Knife | blade length 3", taper ground cutlery single steel blade, ergonomically designed slip resistant grip | 25 | pc | 2 |
| 13 | Tool Holster | leather, 3 pocket & 4 holes with belt | 25 | pc | 2 |
| 14 | Pull Push Rule | blade length 8 mtrs, blade width 1", high impact ABS case with durable rubber corrosion resistant tru-zero end | 25 | pc | 2 |
| 15 | Claw Hammer | 16 oz., forged steel construction, hardened and tempered steel head, smooth face, wooden handle | 10 | pc | 2 |
| 16 | Heat Gun | 1600 watts, 230v,60 Hz, 12.5 amp. dual temperature, with different nozzle | 2 | unit | 2 |
| 17 | | | | | |

Handwritten signature/initials

Procurement of CMU Boxes, Tools and Equipment and Mock-ups for the Mobile Training Laboratories (MTLs).

**TESDA Lanao Del Sur Provincial Office
3rd Floor, Line Agencies Bldg., New Provincial Capitol, Compound Marawi City**

| NO. | ITEM | AGENCY SPECS | QTY | UNIT | No. Of Box |
|---|----------------|---|-----|---------|------------|
| 18 | Power Drill | drilling cap.:10mm, cap. wood: 20mm, wattage 350w, no load speed: 0-2500rpm, weight 1.1 kg., Rev.- for rotation, 3/8" capacity. 220VAC, 60Hz | 2 | unit | 2 |
| 19 | Multi-Tester | analog, standard-size analog multimeter for measuring voltage, current, and resistance. An auxiliary connector is also provided for checking transistors. Specifications: •DC Voltage Range: 0 to 1000V in seven ranges •AC Voltage Range: 0 to 1000V in five ranges •DC Current Range: 0 to 250mA in four ranges •Resistance Range: x1 to 20KW in four ranges •Transistor hFE Range: -0 to 1000 •Transistors Leakage Current (ICEO) Range: -0 to 150mAAF Output Range: -10dB to +22dB | 5 | unit | 2 |
| 20 | Clamp Ammeter | digital max. AC voltage measurement 600V, max. AC current measurement 400Aac, max. DC voltage measurement 600Vdc, max. resistance measurement 400ohms, battery type AAA, clamp meter type, continuity current, frequency, resistance, voltage, display type LCD, jaw capacity, bus bars 10x34mm, safety category voltage, 300V, 600V | 2 | unit | 2 |
| 21 | Pipe Vise | capacity 2", material steel, d with swivel base with dual locking nuts, 360 degrees of rotation. | 2 | pc | 2 |
| 22 | Laptop | 15.6", Core i7, 1.40GHz, wide screen, 1TB hard drive, 8GB DDR3 memory, NVIDIA GTX 670MX graphic processor, 3GB video memory, Gigabit 10/100/1000Mbps IEEE802.11b/g/n Wireless LAN, web camera, HDMI, Bluetooth, USB2.0, USB3.0, with Windows 8 OS, up to 6 hours charge-in-use battery, DVDRW super Multi with 1 year warranty | 1 | unit | 2 |
| 23 | MS Office 2013 | Home & Student 1 user | 1 | unit | 2 |
| 24 | Projector | LCD Projector Portable, RGB liquid crystal shutter projection system (3LCD), White Light Output 2,600 lumens, Colour Light Output 2,600 lumens, XGA Resolution, lightweight: less than 2 kgs. | 1 | unit | 2 |
| 25 | HDMI cable | 3 meters, v1.4A HDMI cable for Projector | 1 | pc | 2 |
| 26 | Whiteboard | wooden whiteboard (2' x 3') with frame, 1 meter collapsible high stand | 1 | pc | 2 |
| 27 | PA System | 550W Portable with Trolley, with 2 wireless mics, 220V, RCA port, with warranty | 1 | unit | 2 |
| 28 | Megaphone | with speak and music switch and volume control, 25w | 1 | unit | 2 |
| 29 | First Aid Kit | First Aid Kit with the contents: betadine, alcohol, adhesive strips, band-aid, disposable gloves, hypoallergenic medical tape (1.25 cm x 9.1m), conforming bandage (5cm), triangular bandage (110m x 110cm), wound dressing no. 15, swab antiseptic, tweezers metal 8 cm, scissors disposable, safety pins assorted (12 pcs), hot and cold compress pack, first aid quick reference guide. | 1 | package | 2 |
| Plumbing NC II Tools and Equipment (for training purposes) | | | | | |

Y
N
[Handwritten signature]

Procurement of CMU Boxes, Tools and Equipment and Mock-ups for the Mobile Training Laboratories (MTLs).

**TESDA Lanao Del Sur Provincial Office
3rd Floor, Line Agencies Bldg., New Provincial Capitol, Compound Marawi City**

| NO. | ITEM | AGENCY SPECS | QTY | UNIT | No. Of Box |
|-----|-------------------------------|--|-----|------|------------|
| 1 | Pipe Wrench | 12" straight, heavy duty, forged alloy steel 12", pipe capacity 2" or 50mm, weight 1.2 kg. cast-iron housing and I-beam handle with full floating forged hook jaw, featuring self cleaning threads with replaceable hook and heel jaws | 5 | pc | 3 |
| 2 | Pipe Wrench | 14" straight, heavy duty, forged alloy steel 12", pipe capacity 2" or 50mm, weight 1.6 kg. cast-iron housing and I-beam handle with full floating forged hook jaw, featuring self cleaning threads with replaceable hook and heel jaws | 5 | pc | 3 |
| 3 | Pull Push Rule | blade length 8 mtrs, blade width 1", high impact ABS case with durable rubber corrosion resistant Inu-zero end | 10 | pc | 3 |
| 4 | Hacksaw | adjustable hacksaw frame with bi-metal hacksaw blade, 24 TPI, aluminum alloy frame and handle | 5 | pc | 3 |
| 5 | Spirit Level | high impact plastic; magnetic; 3 vials; Length:24" | 5 | pc | 3 |
| 6 | Pipe Reamer | 2" capacity, ratchet type with steel handle, 1/8-2" capacity, suitable for use with power drives | 5 | pc | 3 |
| 7 | Pipe Cutter | max. capacity 1/8-2" for steel or ductile iron pipes with steel handle | 5 | pc | 3 |
| 8 | Adjustable Wrench | alloy steel, 0 - 2" jaw opening, 10" length | 5 | pc | 3 |
| 9 | Mechanical Plier | mechanical, plastic dipped insulated handle, 6" length, rust-resistant chrome finish, two position adjustable joint pliers | 5 | pc | 3 |
| 10 | Pipe Vise | capacity 2", material steel, d with swivel base with dual locking nuts, 360 degrees of rotation. | 2 | pc | 3 |
| 11 | Pipe Threader | drop head with 3 sets of head and dies, sizes (1/2", 3/4", 1") | 2 | pc | 3 |
| 12 | Portable Tri-stand Chain Vise | 1/8 to 6 in., rear pipe support, rugged tool tray capacity: 1/8" - 6", leg locking: over center tool tray | 3 | pc | 3 |
| 13 | Manual Pressure Test Pump | 6 mpa, 860 psi max. pressure, 12 L. capacity, with brass pump valve | 1 | pc | 3 |
| 14 | Socket Fusion Machine | 20 mm - 32 mm cap, 3/4", 1", 1-1/4" and 1-1/2", 220V, 1600w | 2 | pc | 3 |
| 15 | Ballpeen hammer | 12 oz., 11 1/2" overall length forged steel construction, hardened and tempered, wooden handle | 5 | pc | 3 |
| 16 | Angle Grinder | 4" diameter, wheel cap, 220V, 60 Hz, single phase, 11,000 rpm, all-ball bearing design and metal gear | 2 | pc | 3 |
| 17 | Electric Portable Drill | 1/2" bit jaw capacity, 220V, single phase, variable speed (0-550 rpm), heavy duty, 1/2" drill chuck | 1 | pc | 3 |
| 18 | Carpenter Steel Square | high tempered aluminum steel, 2" x 16" x 24", 5-60 and 30-degree angle markings, high tempered aluminum for maximum durability, 1/8-inch graduations for long-term visibility, body: 24 by 2-inches, tongue: 16 by 1-1/2" | 4 | pc | 3 |
| 19 | Claw Hammer | 16 oz., forged steel construction, hardened and tempered steel head, smooth face, wooden handle | 5 | pc | 3 |
| 20 | Paint Brush | 1/2" round trim brush soft bristle, tin-plated ferrules | 10 | pc | 3 |
| 21 | Hand Gloves | 5 finger, poly/cotton blend with a latex coated palm | 25 | pc | 3 |

Handwritten initials and marks at the bottom right corner of the page.

Procurement of CMU Boxes, Tools and Equipment and Mock-ups for the Mobile Training Laboratories (MTLs).

**TESDA Lanao Del Sur Provincial Office
3rd Floor, Line Agencies Bldg., New Provincial Capitol, Compound Marawi City**

| NO. | ITEM | AGENCY SPECS | QTY | UNIT | No. Of Box |
|--|---------------------------|--|-----|---------|------------|
| 22 | Safety Hard Hat | V-rib, yellow ball-cap style hard hat with 6 point ratchet-type headgear, 2 point chin strap and V rib on top, polyethylene material | 25 | pc | 3 |
| 23 | Safety Shoes | heavy duty steel toe cap, waterproof, anti static (sizes 40-42) Its anti-static and heat resistant (up to 300 degree C/572 degree F) with TPU SAFETY cell construction steel toe cap | 25 | pc | 3 |
| 24 | Safety Goggles | clear polycarbonate, woven elastic strap (adjustable) | 25 | pc | 3 |
| 25 | Water Meter | multi jet plastic meter, 1/2" NPT, 20 gpm, brass body | 1 | pc | 3 |
| 26 | Water Closet | flush type, ceramic, dimension (LxWxH): 684x430x787 mm, flushing action: siphonic, single/dual flush: single flush, flush Volume: 6L, flushing activation: front lever, rough-in: 305mm, discharge: floor cover | 1 | pc | 3 |
| 27 | Lavatory with Faucet | center hole, with mixing hot and cold faucet, ceramic, wall hung type, wall hung sink, 4-inch center faucet holes, front overflow, self-draining deck area with contoured back and side splash shields | 2 | pc | 3 |
| 28 | Kitchen Sink with Faucet | stainless steel, rust and heat resistant, grade 304, 74 cm x 51.5 cm, 16.2 mm outlet hole | 1 | pc | 3 |
| 29 | Single Point Water Heater | 4.5kw, 220V, 60 Hz, 2 psi min water pressure, 55 psi, 2 L/min minimum water flow, 1/2" BSP | 2 | pc | 3 |
| 30 | Laptop | 15.6", Core i7, 1.40GHz, wide screen, 1TB hard drive, 8GB DDR3 memory, NVIDIA GTX 670MX graphic processor, 3GB video memory, Gigabit 10/100/1000Mbps IEEE802.11b/g/n Wireless LAN, web camera, HDMI, Bluetooth, USB2.0, USB3.0, with Windows 8 OS, up to 6 hours charge-in-use battery, DVDRW super Multi with 1 year warranty | 1 | unit | 3 |
| 31 | MS Office 2013 | Home & Student 1 user | 1 | unit | 3 |
| 32 | Projector | LCD Projector Portable, RGB liquid crystal shutter projection system (3LCD), White Light Output 2,800 lumens, Colour Light Output 2,600 lumens, XGA Resolution, lightweight: less than 2 kgs. | 1 | unit | 3 |
| 33 | HDMI cable | 3 meters, v1.4A HDMI cable for Projector | 1 | pc | 3 |
| 34 | Whiteboard | wooden whiteboard (2' x 3') with frame, 1 meter collapsible high stand | 1 | pc | 3 |
| 35 | PA System | 550W Portable with Trolley, with 2 wireless mics, 220V, RCA port, with warranty | 1 | unit | 3 |
| 36 | Megaphone | with speak and music switch and volume control, 25w | 1 | unit | 3 |
| 37 | First Aid Kit | First Aid Kit with the contents: betadine, alcohol, adhesive strips, band-aid, disposable gloves, hypoallergenic medical tape (1.25 cm x 9.1m), conforming bandage (5cm), triangular bandage (110m x 110cm), wound dressing no. 15, swab antiseptic, tweezers metal 8 cm, scissors disposable, safety pins assorted (12 pcs), hot and cold compress pack, first aid quick reference guide. | 1 | package | 3 |
| Small Engine Repair (Motorcycle/Small Engine Servicing NC II) Tools and Equipment (for training purposes) | | | | | |
| 1 | Impact Drive Tool | 4pcs, 1/2" Impact Driver Set, heavy duty. | 10 | set | 4 |

T
N
96
atx

Procurement of CMU Boxes, Tools and Equipment and Mock-ups for the Mobile Training Laboratories (MTLs).

**TESDA Lanao Del Sur Provincial Office
3rd Floor, Line Agencies Bldg., New Provincial Capitol, Compound Marawi City**

| NO. | ITEM | AGENCY SPECS | QTY | UNIT | No. Of Box |
|-----|----------------------------|--|-----|------|------------|
| 2 | Multi-Tester | analog, standard-size analog multimeter for measuring voltage, current, and resistance. An auxiliary connector is also provided for checking transistors. Specifications: •DC Voltage Range: 0 to 1000V in seven ranges •AC Voltage Range: 0 to 1000V in five ranges •DC Current Range: 0 to 250mA in four ranges •Resistance Range: x1 to 20KW in four ranges •Transistor hFE Range: -0 to 1000 -Transistors Leakage Current (ICEO) Range: -0 to 150mAAF Output Range: -10dB to +22dB | 10 | pc | 4 |
| 3 | Oiler | metal case, 1/2 liter cap | 10 | pc | 4 |
| 4 | Steel Brush | wooden handle | 10 | pc | 4 |
| 5 | Hacksaw | adjustable hacksaw frame with bi-metal hacksaw blade, 24 TPI, aluminum alloy frame and handle | 10 | pc | 4 |
| 6 | Center Punch | high speed steel, 5x125 mm | 10 | pc | 4 |
| 7 | Cold Chisel | flat blade, 1" (W), 6" (L), hardened steel | 10 | pc | 4 |
| 8 | Fly Wheel/Magneto Puller | universal type, six in one fly wheel/ magneto puller | 10 | pc | 4 |
| 9 | Oil Seal Remover/Installer | pointed tip, hardened steel w/ straight handle, 3 pcs per set | 10 | set | 4 |
| 10 | Piston Ring Compressor | self locking w/ L wrench steel, range 2 1/8" to 5 inch diameter | 10 | pc | 4 |
| 11 | Valve Spring Compressor | spring loaded offset jaw overhead valve spring compressor, steel | 10 | pc | 4 |
| 12 | Clutch Assembly Remover | universal compressor clutch hub for removal and installation | 10 | pc | 4 |
| 13 | Electricians Plier | overall length 6, knife length: 5/8", material: carbon steel handle finished: plastic dipped | 10 | pc | 4 |
| 14 | Diagonal Cutting Plier | dyna grip, 152mm/6" inches carbon steel | 10 | pc | 4 |
| 15 | Mechanical Plier | 8", insulated handle | 10 | pc | 4 |
| 16 | Vise Gripped Plier | 10R straight jaw | 10 | pc | 4 |
| 17 | Feeler Gauge | 26 blade feeler gauge set, metric & English marked gauge | 10 | pc | 4 |
| 18 | Screwdriver, Flat | 8", magnetic tip, chrome vanadium, plastic handle | 10 | pc | 4 |
| 19 | Screwdriver, Philips | 8", magnetic tip, chrome vanadium, plastic handle | 10 | pc | 4 |
| 20 | Balpeen hammer | 12 oz., 11 1/2" overall length forged steel construction, hardened and tempered, wooden handle | 10 | pc | 4 |
| 21 | Hammer, Brass/copper | 1 lb., wooden handle | 10 | pc | 4 |
| 22 | Hammer, Plastic | 1 lb, wooden handle, plastic tip hammer | 10 | pc | 4 |
| 23 | Wrench, Sparkplug | 19x16 mm, hexagonal w/ handle | 10 | pc | 4 |
| 24 | Wrench, Combination | 6mm,8mm,10mm,11mm,12mm,13mm,14mm,15mm, 16mm,17mm,19mm, 21mm,22mm, 24 mm, chrome vanadium steel | 10 | set | 4 |
| 25 | Wrench, Socket | 8 - 32 mm., black, 1/2" drive | 10 | set | 4 |
| 26 | Wrench, T-type | 8, 10, 12, 14 mm | 10 | set | 4 |
| 27 | Hand Tractor Engine | diesel engine, single piston, 4 stroke direct injection, 10-12 hp | 2 | unit | 4 |

Handwritten signature/initials

Procurement of CMU Boxes, Tools and Equipment and Mock-ups for the Mobile Training Laboratories (MTLs).

TESDA Lanao Del Sur Provincial Office

3rd Floor, Line Agencies Bldg., New Provincial Capitol, Compound Marawi City

| NO. | ITEM | AGENCY SPECS | QTY | UNIT | No. Of Box |
|-----|----------------|--|-----|---------|------------|
| 28 | Laptop | 15.6", Core i7, 1.40GHz, wide screen, 1TB hard drive, 8GB DDR3 memory, NVIDIA GTX 670MX graphic processor, 3GB video memory, Gigabit 10/100/1000Mbps IEEE802.11b/g/n Wireless LAN, web camera, HDMI, Bluetooth, USB2.0, USB3.0, with Windows 8 OS, up to 6 hours charge-in-use battery, DVDRW super Multi with 1 year warranty | 1 | unit | 4 |
| 29 | MS Office 2013 | Home & Student 1 user | 1 | unit | 4 |
| 30 | Projector | LCD Projector Portable, RGB liquid crystal shutter projection system (3LCD), White Light Output 2,600 lumens, Colour Light Output 2,600 lumens, XGA Resolution, lightweight: less than 2 kgs. | 1 | unit | 4 |
| 31 | HDMI cable | 3 meters, v1.4A HDMI cable for Projector | 1 | pc | 4 |
| 32 | Whiteboard | wooden whiteboard (2' x 3') with frame, 1 meter collapsible high stand | 1 | pc | 4 |
| 33 | PA System | 550W Portable with Trolley, with 2 wireless mics, 220V, RCA port, with warranty | 1 | unit | 4 |
| 34 | Megaphone | with speak and music switch and volume control, 25w | 1 | unit | 4 |
| 35 | First Aid Kit | First Aid Kit with the contents: betadine, alcohol, adhesive strips, band-aid, disposable gloves, hypoallergenic medical tape (1.25 cm x 9.1m), conforming bandage (5cm), triangular bandage (110m x 110cm), wound dressing no. 15, swab antiseptic, tweezers metal 8 cm, scissors disposable, safety pins assorted (12 pcs), hot and cold compress pack, first aid quick reference guide. | 1 | package | 4 |

Handwritten signature and initials in the bottom right corner of the page.

**Procurement of CMU Boxes, Tools and Equipment and Mock-ups for
the Mobile Training Laboratories (MTLs).**

**TESDA Lanao Del Sur Provincial Office
3rd Floor, Line Agencies Bldg., New Provincial Capitol, Compound
Marawi City**

| No. | Item / Description | Qty. | Unit | No. of Mock-up |
|--|---|------|-------|----------------|
| Electrical Installation and Maintenance (EIM) NC II Mock-up | | | | |
| 1 | Electrical Installation Maintenance (EIM) Mock-Up | 1 | lot | 1 |
| | SUPPLIES AND MATERIALS | | | |
| 2 | Heat gun, 1200 watts | 1 | pc | 1 |
| 3 | PVC adapter with lock nuts | 20 | pc | 1 |
| 4 | Circuit breaker, 30A | 2 | pc | 1 |
| 5 | 1/2" diameter PVC pipe | 2 | meter | 1 |
| 6 | Cable ties, 100 pcs./pack | 1 | pack | 1 |
| 7 | Incandescent bulb, 220V, 25W | 5 | pc | 1 |
| 8 | One pole switch with plate, flush type | 5 | pc | 1 |
| 9 | Three way switch with plate, flush type | 5 | pc | 1 |
| 10 | Four way switch with plate, flush type | 5 | pc | 1 |
| 11 | Lamp receptacle 4" X 4" surface type | 5 | pc | 1 |
| 12 | Photo electrical (photocell) | 1 | pc | 1 |
| 13 | Convenience outlet, universal type | 5 | pc | 1 |
| 14 | Floor outlet, round type | 1 | pc | 1 |
| 15 | Ground fault current interrupter | 1 | pc | 1 |
| 16 | Circuit breaker 60A with built in housing | 1 | pc | 1 |
| 17 | Terminal block 15A 12 slots | 40 | pc | 1 |
| 18 | Automotive Wire #14 AWG (1 solid and 1 stranded) | 2 | roll | 1 |
| 19 | Terminal lug, Y type | 150 | pc | 1 |
| This include supplies and materials required in the fabrication of mock-up | | | | |
| Plumbing NC II Mock-up | | | | |
| 1 | Plumbing Mock-up (Labor Cost) | 1 | lot | 1 |
| | SUPPLIES AND MATERIALS | | | |
| 2 | 4" dia PVC Pipe (Orange) | 1 | pc | 1 |
| 3 | 4" dia. PVC Elbow 90 deg. | 1 | pc | 1 |
| 4 | 4" dia. PVC Elbow 45 deg. | 1 | pc | 1 |
| 5 | 4" dia. PVC Clean Out | 1 | pc | 1 |
| 6 | 4" x 3" PVC Wye | 1 | pc | 1 |
| 7 | 4" x 2" PVC Wye | 3 | pc | 1 |
| 8 | 3" dia. PVC pipe | 1 | pc | 1 |
| 9 | 3" PVC Elbow | 1 | pc | 1 |
| 10 | 3" PVC Elbow 45 deg. | 1 | pc | 1 |
| 11 | 3" x 2" PVC Tee | 1 | pc | 1 |
| 12 | 3" x 3" PVC Tee | 1 | pc | 1 |
| 13 | 2" dia PVC Pipe | 2 | pc | 1 |
| 14 | 2" dia. PVC Elbow 45 deg. | 3 | pc | 1 |
| 15 | 2" dia. PVC Elbow 90 deg. | 3 | pc | 1 |
| 16 | 2" PVC Tee | 4 | pc | 1 |
| 17 | 2" PVC P-trap | 2 | pc | 1 |
| 18 | 1/2" dia. PPr pipe | 2 | pc | 1 |
| 19 | 1/2" dia. PPr elbow | 7 | pc | 1 |
| 20 | 1/2" dia. PPr tee | 4 | pc | 1 |
| 21 | 1/2" dia. PPr elbow connector | 6 | pc | 1 |
| 22 | 1/2" dia. PPr male connector | 2 | pc | 1 |
| 23 | 1/2" dia. PPr union | 3 | pc | 1 |
| 24 | 1/2" dia. PPr coupling | 4 | pc | 1 |

TN
16

**Procurement of CMU Boxes, Tools and Equipment and Mock-ups for
the Mobile Training Laboratories (MTLs).**

**TESDA Lanao Del Sur Provincial Office
3rd Floor, Line Agencies Bldg., New Provincial Capitol, Compound
Marawi City**

| No. | Item / Description | Qty. | Unit | No. of Mock-up |
|--|--|------|-------|----------------|
| 25 | Urinal 480mm X 730mm X 730mm with complete accessories | 1 | unit | 1 |
| 26 | Shower head with complete accessories | 1 | unit | 1 |
| 27 | 1/2 x 7/8 flexible hose | 1 | pc | 1 |
| 28 | 1/2 x 1/2" angle valve | 3 | pc | 1 |
| 29 | 3/4" x 4' x 8' Marine Plywood | 1 | pc | 1 |
| 30 | 2" x 2" x 12' Lumber | 4 | pc | 1 |
| 31 | Teflon Tape | 10 | pc | 1 |
| 32 | Metal hinges 2" X 4", heavy duty | 3 | pc | 1 |
| This include supplies and materials required in the fabrication of mock-up | | | | |
| Small Engine Repair (Motorcycle/Small Engine Servicing NC II) Tools and Equipment Mock-up | | | | |
| 1 | Motorcycle/Small Engine Collapsible Mock-Up | 1 | lot | 1 |
| SUPPLIES AND MATERIALS: | | | | |
| 2 | Auto wire, stranded # 16 | 1 | roll | 1 |
| 3 | Electrical tape, large black | 2 | pc | 1 |
| 4 | Head light assembly, 12 volts rectangular | 1 | pc | 1 |
| 5 | signal light assembly, 12 volts | 2 | pair | 1 |
| 6 | Horn, 12 volts | 1 | pc | 1 |
| 7 | Stop light switch, push button | 1 | pc | 1 |
| 8 | Signal light switch, double throw, toggle switch | 1 | pc | 1 |
| 9 | Ignition switch, gas engine type | 1 | pc | 1 |
| 10 | Signal light relay, 12 volts | 1 | pc | 1 |
| 11 | Push button switch for horn | 1 | pc | 1 |
| 12 | Motorcycle storage battery, 12 volts maintenance free | 1 | pc | 1 |
| 13 | Harness cover, 3/8" diameter (140/4) | 4 | meter | 1 |
| 14 | Harness connector, 6 terminals | 4 | pc | 1 |
| 15 | Male terminal, flat | 30 | pc | 1 |
| 16 | Female terminal, flat | 30 | pc | 1 |
| 17 | Headlight switch or toggle switch, single throw | 1 | pc | 1 |
| 18 | Crocodile clip, medium, red and black | 1 | pair | 1 |
| 19 | 3/16" diameter X 3/4" stove bolt, stainless | 20 | pc | 1 |
| 20 | 3/16" diameter hole, eye terminal | 10 | pc | 1 |
| 21 | Four stroke motorcycle engine, 125 or 155cc, surplus | 1 | unit | 1 |
| This include supplies and materials required in the fabrication of mock-up | | | | |

TW
16

Procurement of CMU Boxes, Tools and Equipment and Mock-ups for the Mobile Training Laboratories (MTLs).

**TESDA Maguindanao 2 Provincial Office
Unit 1, 2nd Floor, ACB Residences, Notre dame, Avenue Cotabato City**

| NO. | ITEM | AGENCY SPECS | QTY | UNIT | No. Of Box |
|---|--|---|-----|------|------------|
| Appliance Repair NC II Tools and Equipment (for training purposes) | | | | | |
| 1 | Soldering Iron | dual wattage, 25 watts/ 120watts, 220 volt 60 Hz, with long life tip, "gun type" | 25 | unit | 3 |
| 2 | Desoldering Tools | desoldering pump with precision regulated return, replacement tip compact, metal housing | 25 | unit | 3 |
| 3 | Screw driver assorted (Phillips and slotted) | 12x7x1 inches, 6 pieces per set, plastic handle | 5 | set | 3 |
| 4 | Long Nose Plier | dyna grip, 152mm/6" inches carbon steel | 5 | pc | 3 |
| 5 | Diagonal Cutting Plier | dyna grip, 152mm/6" inches carbon steel | 5 | pc | 3 |
| 6 | Nut Drivers | rust-resistant, nickel-plated bar, hexagonal shank, includes: 5mm, 6mm, 7mm, 8mm, 9mm, 10mm, 11mm | 5 | set | 3 |
| 7 | Wrench, Combination | 6mm,8mm,10mm,11mm,12mm,13mm,14mm,15mm, 16mm,17mm,19mm, 21mm,22mm, 24 mm, chrome vanadium steel | 5 | set | 3 |
| 8 | Wire Stripper | automatic, cap. 1.5mm to 3.5mm | 10 | pc | 3 |
| 9 | Balpeen hammer | 12 oz., 11 1/2" overall length forged steel construction, hardened and tempered, wooden handle | 5 | pc | 3 |
| 10 | Flashlight | LED, 3 volts/6 volts, rechargeable | 5 | pc | 3 |
| 11 | Detector Light | test light, 220 volts | 5 | pc | 3 |
| 12 | Paint Brush | 4 inches width, wooden handle | 25 | pc | 3 |
| 13 | Microwave Oven | power capacity: 220V 1300 watts, interior capacity 20 liters, 8 programmes, defrost option, 26cm diameter rotating turntable, digital | 1 | unit | 3 |
| 14 | Washing Machine with dryer | power capacity: 500w, 220V, rust proof body, gear drive system, dolphin drive pulsator, washing capacity (dry weight) 7.5kg, spinning capacity (dry weight) 5.5kg, width should be more than 50 cm and length of not more than 100 cm | 1 | unit | 3 |
| 15 | Electric Fan | power capacity: 220V, 100w, 60Hz, 3 speed rotary switch, 18 inch metal blade, round/stable plastic base, thermal fuse protection, adjustable height stand fan | 1 | unit | 3 |
| 16 | Electric Rice Cooker | power capacity: 700w, 220V, 60Hz, automatic cooking feature, auto shutoff, glass lid, non-stick coated aluminum pan, includes measuring cup and rice scoop | 1 | unit | 3 |

7
2
96

Procurement of CMU Boxes, Tools and Equipment and Mock-ups for the Mobile Training Laboratories (MTLs).

**TESDA Maguindanao 2 Provincial Office
Unit 1, 2nd Floor, ACB Residences, Notre dame, Avenue Cotabato City**

| NO. | ITEM | AGENCY SPECS | QTY | UNIT | No. Of Box |
|-----|--------------------|--|-----|------|------------|
| 17 | Electric Flat Iron | power capacity:1000w, 220V, 60 Hz, non-stick Teflon soleplate, thermal fuse protected, variable temperature control, automatic thermostat Control, pilot lamp indicator | 1 | unit | 3 |
| 18 | Coffee Maker | power capacity: 550w, 220V, 60Hz, glass pitcher, anti-drip feature, 6 cup water capacity, water level indicator, swing-out filter basket | 1 | unit | 3 |
| 19 | Oven Toaster | power capacity: 1000w, 220V, 60Hz, stainless steel, 8 liter capacity, 15 minute timer, slide out chrome crumb rack, includes baking tray | 1 | unit | 3 |
| 20 | Blender | 1.5 liter capacity, rated voltage, 230V, 60Hz, power consumption: 300 watts, sharp stainless steel blade, safety lock switch, with plastic stirrer for easy mixing | 1 | unit | 3 |
| 21 | Multi Tester | analog, standard size analog multimeter for measuring voltage, current and resistance. An auxiliary connector is also provided for checking transistors. SPECIFICATION: •DC Voltage Range: 0 to 1000V in seven ranges •AC Voltage Range: 0 to 1000V in five ranges •DC Current Range: 0 to 250mA in four ranges •Resistance Range: x1 to 200MEG in four ranges •Transistor hFE Range: -0 to 1000 •Transistors Leakage Current (ICEO) Range: -0 to 150mAAF Output Range: -10dB to +22dB | 25 | unit | 3 |
| 22 | Multi Tester | Digital Multi meters are standard digital multimeter for measuring voltage, current, and resistance with 3-1/2 digit LCD display. This meter measures only 138mm x 70mm x 32mm and weighs approximately 140 grams, including battery. SPECIFICATION: •DC Voltage Range: 200mV to 600V in five ranges (auto ranging) •AC Voltage Range: 2V to 600V in four ranges (auto ranging) •DC Current Range: 200mA to 10A in six ranges •Resistance Range: 200 Ohms to 20M in six ranges Transistor hFE Test Range: 0 to 2000 | 25 | unit | 3 |
| 23 | Laptop | 15.6", Core i7, 1.40GHz, wide screen, 1TB hard drive, 8GB DDR3 memory, NVIDIA GTX 670MX graphic processor, 3GB video memory, Gigabit 10/100/1000Mbps IEEE802.11b/g/n Wireless LAN, web camera, HDMI, Bluetooth, USB2.0, USB3.0, with Windows 8 OS, up to 6 hours charge-in-use battery, DVDRW super Multi with 1 year warranty | 1 | unit | 3 |
| 24 | MS Office 2013 | Home & Student 1 user | 1 | unit | 3 |

TN
af

Procurement of CMU Boxes, Tools and Equipment and Mock-ups for the Mobile Training Laboratories (MTLs).

**TESDA Maguindanao 2 Provincial Office
Unit 1, 2nd Floor, ACB Residences, Notre dame, Avenue Cotabato City**

| NO. | ITEM | AGENCY SPECS | QTY | UNIT | No. Of Box |
|---|-----------------------|--|-----|---------|------------|
| 25 | Projector | LCD Projector Portable, RGB liquid crystal shutter projection system (3LCD), White Light Output 2,600 lumens, Colour Light Output 2,600 lumens, XGA Resolution, lightweight: less than 2 kgs. | 1 | unit | 3 |
| 26 | HDMI cable | 3 meters, v1.4A HDMI cable for Projector | 1 | pc | 3 |
| 27 | Whiteboard | wooden whiteboard (2' x 3') with frame, 1 meter collapsible high stand | 1 | pc | 3 |
| 28 | PA System | 550W Portable with Trolley, with 2 wireless mics, 220V, RCA port, with warranty | 1 | unit | 3 |
| 29 | Megaphone | with speak and music switch and volume control, 25w | 1 | unit | 3 |
| 30 | First Aid Kit | First Aid Kit with the contents: betadine, alcohol, adhesive strips, band-aid, disposable gloves, hypoallergenic medical tape (1.25 cm x 9.1m), conforming bandage (5cm), triangular bandage (110m x 110cm), wound dressing no. 15, swab antiseptic, tweezers metal 8 cm, scissors disposable, safety pins assorted (12 pcs), hot and cold compress pack, first aid quick reference guide. | 1 | package | 3 |
| Bread and Pastry NC II Tools and Equipment (for training purposes) | | | | | |
| 1 | Measuring Cup, dry | stainless steel, 4 pcs/set (1c , 1/2c, 1/3c & 1/4c) | 12 | pc | 3 |
| 2 | Measuring Cup, liquid | glass graduated, 250 ml capacity | 12 | pc | 3 |
| 3 | Measuring Spoon | Stainless steel 6 pcs/set(1/8 tsp, 1/4 tsp, 1/2tsp, 1 tsp 1/2 tbsp, 1 tbsps) | 12 | set | 3 |
| 4 | Cake Turn Table | plastic cake turntable with locking switch, rubberized feet, white, 12.6x12.6x3.54 inches (LxWxH) | 10 | pc | 3 |
| 5 | Decorating Tips | stainless steel, 24-piece cake decorating tip set, package size: 17cm x 12cm x 5cm (6.69 x 4.72 x 1.97inches) | 25 | set | 3 |
| 6 | Rolling Pin | wooden, size 33.5 x 5cm, light weight comfortable grip | 25 | pc | 3 |
| 7 | Pie Plate, size 6" | aluminum pie pan, 6" diameter x 5/8 in deep, heavy weight round pan | 10 | pc | 3 |
| 8 | Pie Plate, size 8" | pie pan, 8" aluminum deep dish pie pan, standard weight aluminum, 8" top outside diameter | 10 | pc | 3 |
| 9 | Pie Plate, size 10" | deep aluminum pie pan, 10" diameter, depth 1-1/4", made of 0.7mm thick satin finished aluminum | 10 | pc | 3 |
| 10 | Jelly Roll Pan | aluminum, dimension: 2" x 13 x 8" (HxWxD) | 10 | pc | 3 |
| 11 | Cake Spring Form Pan | heavy aluminum spring form pan, heavy duty frame, spring form sides for easy removal, size 9 x 3" | 10 | pc | 3 |

Handwritten signature/initials

Procurement of CMU Boxes, Tools and Equipment and Mock-ups for the Mobile Training Laboratories (MTLs).

**TESDA Maguindanao 2 Provincial Office
Unit 1, 2nd Floor, ACB Residences, Notre dame, Avenue Cotabato City**

| NO. | ITEM | AGENCY SPECS | QTY | UNIT | No. Of Box |
|-----|----------------------|--|-----|------|------------|
| 12 | Pie Cutter | triple riveted pizza cutter, made of stainless steel, rolling wheel slicer, 6" | 10 | pc | 3 |
| 13 | Rubber Scraper | rubber head, high heat resistant, flexible, 12", color white | 25 | pc | 3 |
| 14 | Spatula | Stainless steel straight blade, 14 inches long with wood handle | 25 | pc | 3 |
| 15 | Cake Stand with tier | 3 tier cake round acrylic cake stand, 3 plates clear, size: 15cm, 20cm, 25cm, 10 inches gap between each tier | 6 | set | 3 |
| 16 | Saucepan | Stainless steel with cover and handle 26cm | 15 | pc | 3 |
| 17 | Ladle | stainless steel, 12 inches, comes with brush finished handle, hole in the handle for easy hanging | 10 | pc | 3 |
| 18 | Chef Knife | 8 inch, stainless steel full tang blade with plastic handle | 12 | pc | 3 |
| 19 | Chopping Board | 12 x 17 inches, polyethylene, easy grip handle, white color | 10 | pc | 3 |
| 20 | Weighing Scale | manual, maximum weight capacity 2kg, graduated by grams, removable and washable tray | 6 | pc | 3 |
| 21 | Grater | made of nonreactive stainless steel easy grip handle | 10 | pc | 3 |
| 22 | Wooden Spoon | wooden turner, size 12 inches | 25 | pc | 3 |
| 23 | Piping Bag | 12 inches, light weight, reusable, flexible polyester, coated can be boiled, dishwasher safe | 25 | pc | 3 |
| 24 | Mixing Bowl | 12 inches diameter, 8-9 quarts capacity, stainless | 15 | pc | 3 |
| 25 | Wire Whisk | 8"/20cm, aluminum, balloon style | 25 | pc | 3 |
| 26 | Electric Mixer | 4 qt. stainless steel bowl, 5 speeds & quick burst button, bowl rest TM mixer stabilizer, doubles as a hand mixer, 220V, 290-watts peak power, versatile attachment set includes traditional beaters, whisk and dough hooks, brushed stainless steel | 5 | unit | 3 |
| 27 | Dough Cutter | dough scraper 6" wide x 4", high polished stainless steel blade | 10 | pc | 3 |
| 28 | Oven (gas) | stainless door, 2 trays oven with tempered glass window, 22-25" collapsible stand | 1 | unit | 3 |
| 29 | Pastry Brush | pastry/basting brush, natural wood handle brushes, 1.5" size | 10 | pc | 3 |
| 30 | Bread Knife | 8", serrated edge stain free high-carbon steel blade texture red polypropylene handle | 10 | pc | 3 |
| 31 | Flour Sifter | stainless steel mesh flour sifter strainer, 12" | 10 | pc | 3 |
| 32 | Baking Sheet | aluminum, 13" x 18" | 15 | pc | 3 |

T N
af

Procurement of CMU Boxes, Tools and Equipment and Mock-ups for the Mobile Training Laboratories (MTLs).

**TESDA Magulindanao 2 Provincial Office
Unit 1, 2nd Floor, ACB Residences, Notre dame, Avenue Cotabato City**

| NO. | ITEM | AGENCY SPECS | QTY | UNIT | No. Of Box |
|--|---------------------|--|-----|---------|------------|
| 33 | Muffin Pans | 12 holes, 3 oz. capacity per holes, aluminum | 25 | pc | 3 |
| 34 | Working Table | high quality stainless steel foldable tables dimension: 3ft x 3ft | 4 | pc | 3 |
| 35 | Gas Stove with tank | 2 burner, made from stainless top body, automatic ignition, with complete accessories | 2 | pc | 3 |
| 36 | Kitchen Sink | Kitchen sink, portable single bowl sink stainless steel, with steel collapsible frame legs, with drain hose, Dimension 50cmx50cmx30cm | 1 | pc | 3 |
| 37 | Weighing Scale | digital, 1000g, maximum weight capacity, battery operated (AAA battery) 0.1 g to 1000g . LCD display battery included. | 5 | pc | 3 |
| 38 | Laptop | 15.6", Core i7, 1.40GHz, wide screen, 1TB hard drive, 8GB DDR3 memory, NVIDIA GTX 670MX graphic processor, 3GB video memory, Gigabit 10/100/1000Mbps IEEE802.11b/g/n Wireless LAN, web camera, HDMI, Bluetooth, USB2.0, USB3.0, with Windows 8 OS, up to 6 hours charge-in-use battery, DVDRW super Multi with 1 year warranty | 1 | unit | 3 |
| 39 | MS Office 2013 | Home & Student 1 user | 1 | unit | 3 |
| 40 | Projector | LCD Projector Portable, RGB liquid crystal shutter projection system (3LCD), White Light Output 2,600 lumens, Colour Light Output 2,600 lumens, XGA Resolution, lightweight: less than 2 kgs. | 1 | unit | 3 |
| 41 | HDMI cable | 3 meters, v1.4A HDMI cable for Projector | 1 | pc | 3 |
| 42 | Whiteboard | wooden whiteboard (2' x 3') with frame, 1 meter collapsible high stand | 1 | pc | 3 |
| 43 | PA System | 550W Portable with Trolley, with 2 wireless mics, 220V, RCA port, with warranty | 1 | unit | 3 |
| 44 | Megaphone | with speak and music switch and volume control, 25w | 1 | unit | 3 |
| 45 | First Aid Kit | First Aid Kit with the contents: betadine, alcohol, adhesive strips, band-aid, disposable gloves, hypoallergenic medical tape (1.25 cm x 9.1m), conforming bandage (5cm), triangular bandage (110m x 110cm), wound dressing no. 15, swab antiseptic, tweezers metal 8 cm, scissors disposable, safety pins assorted (12 pcs), hot and cold compress pack, first aid quick reference guide. | 1 | package | 3 |
| Cookery NC II Tools and Equipment (for training purposes) | | | | | |
| 1 | Chef Knife | 8 inch, stainless steel full tang blade with plastic handle | 10 | pc | 3 |
| 2 | Boning Knife | 6 inches, stainless steel with sharp cutting edge with plastic handle | 8 | pc | 3 |

TN pd
etj

Procurement of CMU Boxes, Tools and Equipment and Mock-ups for the Mobile Training Laboratories (MTLs).

**TESDA Maguindanao 2 Provincial Office
Unit 1, 2nd Floor, ACB Residences, Notre dame, Avenue Cotabato City**

| NO. | ITEM | AGENCY SPECS | QTY | UNIT | No. Of Box |
|-----|--------------------------|--|-----|------|------------|
| 3 | Oyster Knife | 7 inches length (3 inches blade and 4 inches handle), stainless steel blade, with comfortable plastic handle | 4 | pc | 3 |
| 4 | Cleaver Knife | 7 inches, stain resistant carbon steel blade | 2 | pc | 3 |
| 5 | Tenderizer | with flat and textured side, non slip, 10 inches 25.5 cm, solid aluminum construction | 8 | pc | 3 |
| 6 | Skimmer | fine, extra fine mesh, 6 inches diameter, with stainless handle | 8 | pc | 3 |
| 7 | Wire Skimmer | small, nickel plated wire oil skimmer, 16 inches long overall, 5 inches diameter bowl | 8 | pc | 3 |
| 8 | Skimmer | spider, 5 inches diameter, natural bamboo handle, constructed of durable stainless steel with versatile woven design | 8 | pc | 3 |
| 9 | Strainer, small | fine, 6" diameter, with stainless handle | 8 | pc | 3 |
| 10 | Siever | small 12" diameter, stainless | 8 | pc | 3 |
| 11 | Strainer, medium | medium, fine stainless steel mesh, 9 inches diameter with stainless handle | 8 | pc | 3 |
| 12 | Turner | solid, stainless steel, with handy loop for hanging, 12 inches long | 8 | pc | 3 |
| 13 | Spatula | Stainless steel straight blade, 14 inches long with wood handle | 8 | pc | 3 |
| 14 | Wooden Spatula | large comfortable handle, 12 inches long, wooden | 8 | pc | 3 |
| 15 | Piping Bag | 12 inches, light weight, reusable, flexible polyester, coated, can be boiled, dishwasher safe | 8 | pc | 3 |
| 16 | Pastry Tubes | steel stainless, set of 24 pcs, different/assorted icing nozzles medium size, constructed of 18/8 quality stainless steel, comes in plastic storage box with lid | 8 | set | 3 |
| 17 | Strainer, chinois medium | medium, 8 inches diameter, stainless steel including handle | 3 | pc | 3 |
| 18 | Strainer, chinois small | small, 5 inches diameter, stainless steel including handle | 2 | pc | 3 |
| 19 | Funnel | general purpose, hard plastic, comes in 4 different sizes (small, medium, large, extra large) | 4 | set | 3 |
| 20 | Measuring Spoon | Stainless steel 6 pcs/set(1/8 tsp, 1/4 tsp, 1/2tsp, 1 tsp 1/2 tbsp, 1 tbsp) | 6 | set | 3 |
| 21 | Food Tong | 12 inches long, stainless steel, and wide shell head with locking | 8 | pc | 3 |
| 22 | Measuring Cup, liquid | glass graduated, 250 ml capacity | 8 | pc | 3 |
| 23 | Ice Cream Scooper | set of three, stainless steel (2 oz, 4 oz and 6 oz) | 2 | set | 3 |
| 24 | Cheese Cloth | 100% cotton 1 yard | 10 | pc | 3 |
| 25 | Serving Spoon | stainless steel, 9 inches long | 24 | pc | 3 |
| 26 | Pepper and Salt Mill | 2 in 1, wooden, 8" | 4 | pc | 3 |

TN
gnd
AG

Procurement of CMU Boxes, Tools and Equipment and Mock-ups for the Mobile Training Laboratories (MTLs).

**TESDA Maguindanao 2 Provincial Office
Unit 1, 2nd Floor, ACB Residences, Notre dame, Avenue Cotabato City**

| NO. | ITEM | AGENCY SPECS | QTY | UNIT | No. Of Box |
|-----|------------------------|--|-----|------|------------|
| 27 | Weighing Scale | analog weighing scale ; maximum weight capacity , 5 kg, graduated by grams , removable and washable tray | 2 | unit | 3 |
| 28 | Weighing Scale | digital, 1000g, maximum weight capacity, battery operated (AAA battery) 0.1 g to 1000g , LCD display battery included. | 2 | unit | 3 |
| 29 | Apple Corer | corer head comfortable on slip handle, corer head is stainless steel | 4 | pc | 3 |
| 30 | Wire Whisk | 8"/20cm, aluminum, balloon style | 8 | pc | 3 |
| 31 | Wire Whisk, medium | medium, 10 inches/25 cm, aluminum, balloon style | 8 | pc | 3 |
| 32 | Wire Whisk, large | heavy duty, stainless steel, 14 inches, balloon style | 2 | pc | 3 |
| 33 | Measuring Cup, dry | stainless steel, 4 pcs/set (1c , 1/2c, 1/3c & 1/4c) | 1 | set | 3 |
| 34 | Chopping Board | 12 x17 inches, polyethylene, easy grip handle, white color | 10 | pc | 3 |
| 35 | Kitchen Scissors | stainless steel blade, size 2 cm x 12 cm x 27 cm, durable and sturdy handle with comfortable grip | 8 | pc | 3 |
| 36 | Soup Ladle | 3 oz capacity, stainless steel, with handle, round bottom | 8 | pc | 3 |
| 37 | Soup Ladle | 6 oz capacity, stainless steel handle, round bottom | 8 | pc | 3 |
| 38 | Soup Ladle | 8 oz capacity, stainless steel handle, round bottom | 3 | pc | 3 |
| 39 | Soup Ladle | 12 oz capacity, stainless handle, round bottom, | 2 | pc | 3 |
| 40 | Mixing Bowl | 12 inches diameter, 8-9 quarts capacity , stainless | 10 | pc | 3 |
| 41 | Kitchen Spoon | solid, stainless steel handle, comfortable non slip handle, round handle 4.5 x2.5 inches | 8 | pc | 3 |
| 42 | Kitchen Spoon | slotted, stainless steel, comfortable non slip handle, round handle 10 x 2.5 inches w/ hole | 8 | pc | 3 |
| 43 | Kitchen Fork | 7.5 cm x 4.5 cm x 37 cm or 10.5 inches, stainless steel, with 2 prongs, round handle | 8 | pc | 3 |
| 44 | Carving Fork | 10.5 inches, stainless steel, with 2 prongs, round handle | 3 | pc | 3 |
| 45 | Pocket Pin Thermometer | analog, temperature range from 0oF to 220 of, dial type | 3 | pc | 3 |
| 46 | Peeler | Straight blade type, dual stainless steel blade, metal handle 5",2"handle,3"blade | 8 | pc | 3 |
| 47 | Stockpot | stainless, 17 quarts capacity (22.7 lit), 12 inches diameter (30.5 cm), depth 31 cm, 4 mm thickness | 2 | pc | 3 |
| 48 | Frying pan | pan, large, non stick, 26 cm diameter | 2 | pc | 3 |

TN
dy

Procurement of CMU Boxes, Tools and Equipment and Mock-ups for the Mobile Training Laboratories (MTLs).

**TESDA Maguindanao 2 Provincial Office
Unit 1, 2nd Floor, ACB Residences, Notre dame, Avenue Cotabato City**

| NO. | ITEM | AGENCY SPECS | QTY | UNIT | No. Of Box |
|-----|---------------------|--|-----|------|------------|
| 49 | Colander | medium, stainless steel, 8 quarts capacity, with base | 2 | pc | 3 |
| 50 | Fish Poacher | medium, 18 inches (L) and 6 inches (w), stainless steel, with handle | 1 | pc | 3 |
| 51 | Casserole | small, stainless steel, 20 cm diameter, with cover | 8 | pc | 3 |
| 52 | Casserole | medium, stainless steel, 24 cm diameter with cover | 4 | pc | 3 |
| 53 | Double Boiler | medium, made from stainless steel, 2 quarts capacity, with lid cover | 1 | pc | 3 |
| 54 | Paellara | 40 cm diameter, (50 cm with handle), constructed of carbon steel, riveted secure melt handle, safe for all heating surfaces including induction | 4 | pc | 3 |
| 55 | Baking Tray | small, main material is carbon, rectangular, size 14 x 10 inches | 8 | pc | 3 |
| 56 | Utility Tray | hard plastic tray, rectangular 14x18 inches | 12 | pc | 3 |
| 57 | Fire Extinguisher | cylinder type, multipurpose ABC dry chemical, powder aluminum valve coated, rechargeable, 5 lbs capacity, with pressure gauge that allows for immediate pressure status check, with wall hanger, meets requirements for underwriter laboratory (UJ) | 1 | unit | 3 |
| 58 | Blender | 1.5 liter capacity, rated voltage, 230V, 60Hz, power consumption: 300 watts, sharp stainless steel blade, safety lock switch, with plastic stirrer for easy mixing | 1 | unit | 3 |
| 59 | Pressure Cooker | aluminum, 2 mm, 6 quarts capacity, pressured handle, central pressure valve with self locking mechanism | 1 | pc | 3 |
| 60 | Gas Stove with tank | 2 burner, made from stainless top body, automatic ignition, with complete accessories | 4 | unit | 3 |
| 61 | Working Table | high quality stainless steel foldable tables dimension: 3ft x 3ft | 4 | pc | 3 |
| 62 | Kitchen Sink | Kitchen sink, portable single bowl sink stainless steel, with steel collapsible frame legs, with drain hose, Dimension 50cmx50cmx30cm | 1 | unit | 3 |
| 63 | Laptop | 15.6", Core i7, 1.40GHz, wide screen, 1TB hard drive, 8GB DDR3 memory, NVIDIA GTX 670MX graphic processor, 3GB video memory, Gigabit 10/100/1000Mbps IEEE802.11b/g/n Wireless LAN, web camera, HDMI, Bluetooth, USB2.0, USB3.0, with Windows 8 OS, up to 6 hours charge-in-use battery, DVDRW super Multi with 1 year warranty | 1 | unit | 3 |
| 64 | MS Office 2013 | Home & Student 1 user | 1 | unit | 3 |
| 65 | Projector | LCD Projector Portable, RGB liquid crystal shutter projection system (3LCD), White Light Output 2,600 lumens, Colour Light Output 2,600 lumens, XGA Resolution, lightweight: less than 2 kgs. | 1 | unit | 3 |

TW pd
df

Procurement of CMU Boxes, Tools and Equipment and Mock-ups for the Mobile Training Laboratories (MTLs).

**TESDA Maguindanao 2 Provincial Office
Unit 1, 2nd Floor, ACB Residences, Notre dame, Avenue Cotabato City**

| NO. | ITEM | AGENCY SPECS | QTY | UNIT | No. Of Box |
|--|-----------------------|--|-----|---------|------------|
| 66 | HDMI cable | 3 meters, v1.4A HDMI cable for Projector | 1 | pc | 3 |
| 67 | Whiteboard | wooden whiteboard (2' x 3') with frame, 1 meter collapsible high stand | 1 | pc | 3 |
| 68 | PA System | 550W Portable with Trolley, with 2 wireless mics, 220V, RCA port, with warranty | 1 | unit | 3 |
| 69 | Megaphone | with speak and music switch and volume control, 25w | 1 | unit | 3 |
| 70 | First Aid Kit | First Aid Kit with the contents: betadine, alcohol, adhesive strips, band-aid, disposable gloves, hypoallergenic medical tape (1.25 cm x 9.1m), conforming bandage (5cm), triangular bandage (110m x 110cm), wound dressing no. 15, swab antiseptic, tweezers metal 8 cm, scissors disposable, safety pins assorted (12 pcs), hot and cold compress pack, first aid quick reference guide. | 1 | package | 3 |
| Electrical Installation and Maintenance NC II Tools and Equipment (for training purposes) | | | | | |
| 1 | Spirit Level | high impact plastic; magnetic; 3 vials; Length:24" | 1 | pc | 2 |
| 2 | Hacksaw | adjustable hacksaw frame with bi-metal hacksaw blade, 24 TPI, aluminum alloy frame and handle | 5 | pc | 2 |
| 3 | Pipe Cutter | max. capacity 1/8-2" for steel or ductile iron pipes with steel handle | 2 | pc | 2 |
| 4 | Pipe Reamer | 2" capacity, ratchet type with steel handle, 1/8-2" capacity, suitable for use with power drives | 2 | pc | 2 |
| 5 | Pipe Threader | drop head with 3 sets of head and dies, sizes (1/2", 3/4", 1") | 2 | unit | 2 |
| 6 | Pipe Bender | manual, 1/2-3/4 inch bending radius, ductile high strength iron | 2 | unit | 2 |
| 7 | Electricians Plier | overall length 6, knife length: 5/8", material: carbon steel handle finished: plastic dipped | 25 | pc | 2 |
| 8 | Long Nose Plier | dyna grip, 152mm/6" inches carbon steel | 25 | pc | 2 |
| 9 | Phillips Screw Driver | 1x75, PH 2 x 100, PH 2x125 plastic and rubberized handle chrome vanadium, shank 4" | 25 | set | 2 |
| 10 | Flat Screw Driver | 3x75, 5x100, 6x125 plastic and rubberized handle chrome vanadium shank 4" | 25 | set | 2 |
| 11 | Wrench, Combination | 6mm,8mm,10mm,11mm,12mm,13mm,14mm,15mm,16mm,17mm,19mm,21mm,22mm,24 mm, chrome vanadium steel | 5 | set | 2 |
| 12 | Wire Stripper | automatic, cap. 1.5mm to 3.5mm | 10 | pc | 2 |
| 13 | Electrician Knife | blade length 3", taper ground cutlery single steel blade, ergonomically designed slip resistant grip | 25 | pc | 2 |
| 14 | Tool Holster | leather, 3 pocket & 4 holes with belt | 25 | pc | 2 |
| 15 | Pull Push Rule | blade length 8 mtrs, blade width 1", high impact ABS case with durable rubber corrosion resistant tru-zero end | 25 | pc | 2 |
| 16 | Claw Hammer | 16 oz., forged steel construction, hardened and tempered steel head, smooth face, wooden handle | 10 | pc | 2 |

T N Jd
af

Procurement of CMU Boxes, Tools and Equipment and Mock-ups for the Mobile Training Laboratories (MTLs).

**TESDA Maguindanao 2 Provincial Office
Unit 1, 2nd Floor, ACB Residences, Notre dame, Avenue Cotabato City**

| NO. | ITEM | AGENCY SPECS | QTY | UNIT | No. Of Box |
|-----|----------------|--|-----|------|------------|
| 17 | Heat Gun | 1600 watts, 230v,60 Hz, 12.5 amp. dual temperature, with different nozzle | 2 | unit | 2 |
| 18 | Power Drill | drilling cap.:10mm, cap. wood: 20mm, wattage 350w, no load speed: 0-2500rpm, weight 1.1 kg., Rev.- for rotation, 3/8" capacity. 220VAC, 60Hz | 2 | unit | 2 |
| 19 | Multi-Tester | analog, standard-size analog multimeter for measuring voltage, current, and resistance. An auxiliary connector is also provided for checking transistors. Specifications: •DC Voltage Range: 0 to 1000V in seven ranges •AC Voltage Range: 0 to 1000V in five ranges •DC Current Range: 0 to 250mA in four ranges •Resistance Range: x1 to 20KW in four ranges •Transistor hFE Range: -0 to 1000 •Transistors Leakage Current (ICEO) Range: -0 to 150mAAF Output Range: -10dB to +22dB | 5 | unit | 2 |
| 20 | Clamp Ammeter | digital max. AC voltage measurement 600V, max. AC current measurement 400Aac, max. DC voltage measurement 600Vdc, max. resistance measurement 400ohms, battery type AAA, clamp meter type, continuity current, frequency, resistance, voltage, display type LCD, jaw capacity, bus bars 10x34mm, safety category voltage, 300V, 600V | 2 | unit | 2 |
| 21 | Pipe Vise | capacity 2", material steel, d with swivel base with dual locking nuts, 360 degrees of rotation. | 2 | pc | 2 |
| 22 | Laptop | 15.6", Core i7, 1.40GHz, w/de screen, 1TB hard drive, 8GB DDR3 memory, NVIDIA GTX 670MX graphic processor, 3GB video memory, Gigabit 10/100/1000Mbps IEEE802.11b/g/n Wireless LAN, web camera, HDMI, Bluetooth, USB2.0, USB3.0, with Windows 8 OS, up to 6 hours charge-in-use battery, DVDRW super Multi with 1 year warranty | 1 | unit | 2 |
| 23 | MS Office 2013 | Home & Student 1 user | 1 | unit | 2 |
| 24 | Projector | LCD Projector Portable, RGB liquid crystal shutter projection system (3LCD), White Light Output 2,600 lumens, Colour Light Output 2,600 lumens, XGA Resolution, lightweight: less than 2 kgs. | 1 | unit | 2 |
| 25 | HDMI cable | 3 meters, v1.4A HDMI cable for Projector | 1 | pc | 2 |
| 26 | Whiteboard | wooden whiteboard (2' x 3') with frame, 1 meter collapsible high stand | 1 | pc | 2 |
| 27 | PA System | 550W Portable with Trolley, with 2 wireless mics, 220V, RCA port, with warranty | 1 | unit | 2 |
| 28 | Megaphone | with speak and music switch and volume control, 25w | 1 | unit | 2 |

7 W 9/2016
af

Procurement of CMU Boxes, Tools and Equipment and Mock-ups for the Mobile Training Laboratories (MTLs).

**TESDA Maguindanao 2 Provincial Office
Unit 1, 2nd Floor, ACB Residences, Notre dame, Avenue Cotabato City**

| NO. | ITEM | AGENCY SPECS | QTY | UNIT | No. Of Box |
|---|-------------------------------|--|-----|---------|------------|
| 29 | First Aid Kit | First Aid Kit with the contents: betadine, alcohol, adhesive strips, band-aid, disposable gloves, hypoallergenic medical tape (1.25 cm x 9.1m), conforming bandage (5cm), triangular bandage (110m x 110cm), wound dressing no. 15, swab antiseptic, tweezers metal 8 cm, scissors disposable, safety pins assorted (12 pcs), hot and cold compress pack, first aid quick reference guide. | 1 | package | 2 |
| Plumbing NC II Tools and Equipment (for training purposes) | | | | | |
| 1 | Pipe Wrench | 12" straight, heavy duty, forged alloy steel 12", pipe capacity 2" or 50mm, weight 1.2 kg. cast-iron housing and I-beam handle with full floating forged hook jaw, featuring self cleaning threads with replaceable hook and heel jaws | 5 | pc | 3 |
| 2 | Pipe Wrench | 14" straight, heavy duty, forged alloy steel 12", pipe capacity 2" or 50mm, weight 1.6 kg. cast-iron housing and I-beam handle with full floating forged hook jaw, featuring self cleaning threads with replaceable hook and heel jaws | 5 | pc | 3 |
| 3 | Pull Push Rule | blade length 8 mtrs, blade width 1", high impact ABS case with durable rubber corrosion resistant inu-zero end | 10 | pc | 3 |
| 4 | Hacksaw | adjustable hacksaw frame with bi-metal hacksaw blade, 24 TPI, aluminum alloy frame and handle | 5 | pc | 3 |
| 5 | Spirit Level | high impact plastic; magnetic; 3 vials; Length:24" | 5 | pc | 3 |
| 6 | Pipe Reamer | 2 " capacity, ratchet type with steel handle, 1/8-2 " capacity, suitable for use with power drives | 5 | pc | 3 |
| 7 | Pipe Cutter | max. capacity 1/8-2 " for steel or ductile iron pipes with steel handle | 5 | pc | 3 |
| 8 | Adjustable Wrench | alloy steel, 0 - 2 " jaw opening, 10" length | 5 | pc | 3 |
| 9 | Mechanical Plier | mechanical, plastic dipped insulated handle, 6 " length, rust-resistant chrome finish, two position adjustable joint pliers | 5 | pc | 3 |
| 10 | Pipe Vise | capacity 2", material steel, d with swivel base with dual locking nuts, 360 degrees of rotation. | 2 | pc | 3 |
| 11 | Pipe Threader | drop head with 3 sets of head and dies, sizes (1/2", 3/4", 1") | 2 | pc | 3 |
| 12 | Portable Tri-stand Chain Vise | 1/8 to 6 in., rear pipe support, rugged tool tray capacity: 1/8" - 6", leg locking: over center tool tray | 3 | pc | 3 |
| 13 | Manual Pressure Test Pump | 6 mpa, 860 psi max. pressure, 12 L. capacity, with brass pump valve | 1 | pc | 3 |
| 14 | Socket Fusion Machine | 20 mm - 32 mm cap, 3/4", 1", 1-1/4" and 1-1/2", 220V, 1600w | 2 | pc | 3 |
| 15 | Ballpeen hammer | 12 oz., 11 1/2" overall length forged steel construction, hardened and tempered, wooden handle | 5 | pc | 3 |
| 16 | Angle Grinder | 4 "diameter, wheel cap, 220V, 60 Hz, single phase, 11,000 rpm, all-ball bearing design and metal gear | 2 | pc | 3 |
| 17 | Electric Portable Drill | 1/2 " bit jaw capacity, 220V, single phase, variable speed (0-550 rpm), heavy duty, 1/2" drill chuck | 1 | pc | 3 |

T. N. G. J.
MS

Procurement of CMU Boxes, Tools and Equipment and Mock-ups for the Mobile Training Laboratories (MTLs).

**TESDA Maguindanao 2 Provincial Office
Unit 1, 2nd Floor, ACB Residences, Notre dame, Avenue Cotabato City**

| NO. | ITEM | AGENCY SPECS | QTY | UNIT | No. Of Box |
|-----|---------------------------|--|-----|------|------------|
| 18 | Carpenter Steel Square | high tempered aluminum steel, 2" x 16" x 24", 5-60 and 30-degree angle markings, high tempered aluminum for maximum durability, 1/8-inch graduations for long-term visibility, body: 24 by 2-inches, tongue: 16 by 1-1/2" | 4 | pc | 3 |
| 19 | Claw Hammer | 16 oz., forged steel construction, hardened and tempered steel head, smooth face, wooden handle | 5 | pc | 3 |
| 20 | Paint Brush | 1/2" round trim brush soft bristle, tin-plated ferrules | 10 | pc | 3 |
| 21 | Hand Gloves | 5 finger, poly/cotton blend with a latex coated palm | 25 | pc | 3 |
| 22 | Safety Hard Hat | V-rib, yellow ball-cap style hard hat with 6 point ratchet-type headgear, 2 point chin strap and V rib on top, polyethylene material | 25 | pc | 3 |
| 23 | Safety Shoes | heavy duty steel toe cap, waterproof, anti static (sizes 40-42) Its anti-static and heat resistant (up to 300 degree C/572 degree F) with TPU SAFETY cell construction steel toe cap | 25 | pc | 3 |
| 24 | Safety Goggles | clear polycarbonate, woven elastic strap (adjustable) | 25 | pc | 3 |
| 25 | Water Meter | multi jet plastic meter, 1/2" NPT, 20 gpm, brass body | 1 | pc | 3 |
| 26 | Water Closet | flush type, ceramic, dimension (LxWxH): 684x430x787 mm, flushing action: siphonic, single/dual flush: single flush, flush Volume: 6L, flushing activation: front lever, rough-in: 305mm, discharge: floor cover | 1 | pc | 3 |
| 27 | Lavatory with Faucet | center hole, with mixing hot and cold faucet, ceramic, wall hung type, wall hung sink, 4-inch center faucet holes, front overflow, self-draining deck area with contoured back and side splash shields | 2 | pc | 3 |
| 28 | Kitchen Sink with Faucet | stainless steel, rust and heat resistant, grade 304, 74 cm x 51.5 cm, 16.2 mm outlet hole | 1 | pc | 3 |
| 29 | Single Point Water Heater | 4.5kw, 220V, 60 Hz, 2 psi min water pressure, 55 psi, 2 L/min minimum water flow, 1/2" BSP | 2 | pc | 3 |
| 30 | Laptop | 15.6", Core i7, 1.40GHz, wide screen, 1TB hard drive, 8GB DDR3 memory, NVIDIA GTX 670MX graphic processor, 3GB video memory, Gigabit 10/100/1000Mbps IEEE802.11b/g/n Wireless LAN, web camera, HDMI, Bluetooth, USB2.0, USB3.0, with Windows 8 OS, up to 6 hours charge-in-use battery, DVDRW super Multi with 1 year warranty | 1 | unit | 3 |
| 31 | MS Office 2013 | Home & Student 1 user | 1 | unit | 3 |
| 32 | Projector | LCD Projector Portable, RGB liquid crystal shutter projection system (3LCD), White Light Output 2,600 lumens, Colour Light Output 2,600 lumens, XGA Resolution, lightweight: less than 2 kgs. | 1 | unit | 3 |
| 33 | HDMI cable | 3 meters, v1.4A HDMI cable for Projector | 1 | pc | 3 |
| 34 | Whiteboard | wooden whiteboard (2' x 3') with frame, 1 meter collapsible high stand | 1 | pc | 3 |
| 35 | PA System | 550W Portable with Trolley, with 2 wireless mics, 220V, RCA port, with warranty | 1 | unit | 3 |

T N 96
of

Procurement of CMU Boxes, Tools and Equipment and Mock-ups for the Mobile Training Laboratories (MTLs).

**TESDA Maguindanao 2 Provincial Office
Unit 1, 2nd Floor, ACB Residences, Notre dame, Avenue Cotabato City**

| NO. | ITEM | AGENCY SPECS | QTY | UNIT | No. Of Box |
|--|----------------------------|--|-----|---------|------------|
| 36 | Megaphone | with speak and music switch and volume control, 25w | 1 | unit | 3 |
| 37 | First Aid Kit | First Aid Kit with the contents: betadine, alcohol, adhesive strips, band-aid, disposable gloves, hypoallergenic medical tape (1.25 cm x 9.1m), conforming bandage (5cm), triangular bandage (110m x 110cm), wound dressing no. 15, swab antiseptic, tweezers metal 8 cm, scissors disposable, safety pins assorted (12 pcs), hot and cold compress pack, first aid quick reference guide. | 1 | package | 3 |
| Small Engine Repair (Motorcycle/Small Engine Servicing NC II) Tools and Equipment (for training purposes) | | | | | |
| 1 | Impact Drive Tool | 4pcs, 1/2" Impact Driver Set, heavy duty. | 10 | set | 4 |
| 2 | Multi-Tester | analog, standard-size analog multimeter for measuring voltage, current, and resistance. An auxiliary connector is also provided for checking transistors. Specifications: •DC Voltage Range: 0 to 1000V in seven ranges •AC Voltage Range: 0 to 1000V in five ranges •DC Current Range: 0 to 250mA in four ranges •Resistance Range: x1 to 20KW in four ranges •Transistor hFE Range: -0 to 1000 -Transistors Leakage Current (ICEO) Range: -0 to 150mAAF Output Range: -10dB to +22dB | 10 | pc | 4 |
| 3 | Oiler | metal case, 1/2 liter cap | 10 | pc | 4 |
| 4 | Steel Brush | wooden handle | 10 | pc | 4 |
| 5 | Hacksaw | adjustable hacksaw frame with bi-metal hacksaw blade, 24 TPI, aluminum alloy frame and handle | 10 | pc | 4 |
| 6 | Center Punch | high speed steel, 5x125 mm | 10 | pc | 4 |
| 7 | Cold Chisel | flat blade, 1" (W), 6" (L), hardened steel | 10 | pc | 4 |
| 8 | Fly Wheel/Magneto Puller | universal type, six in one fly wheel/ magneto puller | 10 | pc | 4 |
| 9 | Oil Seal Remover/Installer | pointed tip, hardened steel w/ straight handle, 3 pcs per set | 10 | set | 4 |
| 10 | Piston Ring Compressor | self locking w/ L wrench steel, range 2 1/8" to 5 inch diameter | 10 | pc | 4 |
| 11 | Valve Spring Compressor | spring loaded offset jaw overhead valve spring compressor, steel | 10 | pc | 4 |
| 12 | Clutch Assembly Remover | universal compressor clutch hub for removal and installation | 10 | pc | 4 |
| 13 | Electricians Plier | overall length 6, knife length: 5/8", material: carbon steel handle finished: plastic dipped | 10 | pc | 4 |
| 14 | Diagonal Cutting Plier | dyna grip, 152mm/6" inches carbon steel | 10 | pc | 4 |
| 15 | Mechanical Plier | 8", insulated handle | 10 | pc | 4 |
| 16 | Vise Gripped Plier | 10R straight jaw | 10 | pc | 4 |
| 17 | Feeler Gauge | 26 blade feeler gauge set, metric & English marked gauge | 10 | pc | 4 |
| 18 | Screwdriver, Flat | 8", magnetic tip, chrome vanadium, plastic handle | 10 | pc | 4 |
| 19 | Screwdriver, Philips | 8", magnetic tip, chrome vanadium, plastic handle | 10 | pc | 4 |
| 20 | Ballpeen hammer | 12 oz, 11 1/2" overall length forged steel construction, hardened and tempered, wooden handle | 10 | pc | 4 |
| 21 | Hammer, Brass/copper | 1 lb., wooden handle | 10 | pc | 4 |

7
N
96
[Signature]

Procurement of CMU Boxes, Tools and Equipment and Mock-ups for the Mobile Training Laboratories (MTLs).

**TESDA Maguindanao 2 Provincial Office
Unit 1, 2nd Floor, ACB Residences, Notre dame, Avenue Cotabato City**

| NO. | ITEM | AGENCY SPECS | QTY | UNIT | No. Of Box |
|-----|---------------------|--|-----|---------|------------|
| 22 | Hammer, Plastic | 1 lb., wooden handle, plastic tip hammer | 10 | pc | 4 |
| 23 | Wrench, Sparkplug | 19x16 mm, hexagonal w/ handle | 10 | pc | 4 |
| 24 | Wrench, Combination | 6mm,8mm,10mm,11mm,12mm,13mm,14mm,15mm,16mm,17mm,19mm, 21mm,22mm, 24 mm, chrome vanadium steel | 10 | set | 4 |
| 25 | Wrench, Socket | 8 - 32 mm., black, 1/2" drive | 10 | set | 4 |
| 26 | Wrench, T-type | 8, 10, 12, 14 mm | 10 | set | 4 |
| 27 | Hand Tractor Engine | diesel engine, single piston, 4 stroke direct injection, 10-12 hp | 2 | unit | 4 |
| 28 | Laptop | 15.6", Core i7, 1.40GHz, wide screen, 1TB hard drive, 8GB DDR3 memory, NVIDIA GTX 670MX graphic processor, 3GB video memory, Gigabit 10/100/1000Mbps IEEE802.11b/g/n Wireless LAN, web camera, HDMI, Bluetooth, USB2.0, USB3.0, with Windows 8 OS, up to 6 hours charge-in-use battery, DVDRW super Multi with 1 year warranty | 1 | unit | 4 |
| 29 | MS Office 2013 | Home & Student 1 user | 1 | unit | 4 |
| 30 | Projector | LCD Projector Portable, RGB liquid crystal shutter projection system (3LCD), White Light Output 2,600 lumens, Colour Light Output 2,600 lumens, XGA Resolution, lightweight: less than 2 kgs. | 1 | unit | 4 |
| 31 | HDMI cable | 3 meters, v1.4A HDMI cable for Projector | 1 | pc | 4 |
| 32 | Whiteboard | wooden whiteboard (2' x 3') with frame, 1 meter collapsible high stand | 1 | pc | 4 |
| 33 | PA System | 550W Portable with Trolley, with 2 wireless mics, 220V, RCA port, with warranty | 1 | unit | 4 |
| 34 | Megaphone | with speak and music switch and volume control, 25w | 1 | unit | 4 |
| 35 | First Aid Kit | First Aid Kit with the contents: betadine, alcohol, adhesive strips, band-aid, disposable gloves, hypoallergenic medical tape (1.25 cm x 9.1m), conforming bandage (5cm), triangular bandage (110m x 110cm), wound dressing no. 15, swab antiseptic, tweezers metal 8 cm, scissors disposable, safety pins assorted (12 pcs), hot and cold compress pack, first aid quick reference guide. | 1 | package | 4 |

Handwritten signature/initials

**Procurement of CMU Boxes, Tools and Equipment and Mock-ups for
the Mobile Training Laboratories (MTLs).**

**TESDA Maguindanao 2 Provincial Office
Unit 1, 2nd Floor, ACB Residences, Notre dame
Avenue Cotabato City**

| No. | Item / Description | Qty. | Unit | No. of Mock-up |
|--|---|------|-------|----------------|
| Electrical Installation and Maintenance NC II Mock-up | | | | |
| 1 | Electrical Installation Maintenance (EIM) Mock-Up | 1 | lot | 1 |
| SUPPLIES AND MATERIALS | | | | |
| 2 | Heat gun, 1200 watts | 1 | pc | 1 |
| 3 | PVC adapter with lock nuts | 20 | pc | 1 |
| 4 | Circuit breaker, 30A | 2 | pc | 1 |
| 5 | 1/2" diameter PVC pipe | 2 | meter | 1 |
| 6 | Cable ties, 100 pcs./pack | 1 | pack | 1 |
| 7 | Incandescent bulb, 220V, 25W | 5 | pc | 1 |
| 8 | One pole switch with plate, flush type | 5 | pc | 1 |
| 9 | Three way switch with plate, flush type | 5 | pc | 1 |
| 10 | Four way switch with plate, flush type | 5 | pc | 1 |
| 11 | Lamp receptacle 4" X 4" surface type | 5 | pc | 1 |
| 12 | Photo electrical (photocell) | 1 | pc | 1 |
| 13 | Convenience outlet, universal type | 5 | pc | 1 |
| 14 | Floor outlet, round type | 1 | pc | 1 |
| 15 | Ground fault current interrupter | 1 | pc | 1 |
| 16 | Circuit breaker 60A with built in housing | 1 | pc | 1 |
| 17 | Terminal block 15A 12 slots | 40 | pc | 1 |
| 18 | Automotive Wire #14 AWG (1 solid and 1 stranded) | 2 | roll | 1 |
| 19 | Terminal lug, Y type | 150 | pc | 1 |
| This include supplies and materials required in the fabrication of mock-up | | | | |
| Plumbing NC II Mock-up | | | | |
| 1 | Plumbing Mock-up (Labor Cost) | 1 | lot | 1 |
| SUPPLIES AND MATERIALS | | | | |
| 2 | 4" dia PVC Pipe (Orange) | 1 | pc | 1 |
| 3 | 4" dia. PVC Elbow 90 deg. | 1 | pc | 1 |
| 4 | 4" dia. PVC Elbow 45 deg. | 1 | pc | 1 |
| 5 | 4" dia. PVC Clean Out | 1 | pc | 1 |
| 6 | 4" x 3" PVC Wye | 1 | pc | 1 |
| 7 | 4" x 2" PVC Wye | 3 | pc | 1 |
| 8 | 3" dia. PVC pipe | 1 | pc | 1 |
| 9 | 3" PVC Elbow | 1 | pc | 1 |
| 10 | 3" PVC Elbow 45 deg. | 1 | pc | 1 |
| 11 | 3" x 2" PVC Tee | 1 | pc | 1 |
| 12 | 3" x 3" PVC Tee | 1 | pc | 1 |
| 13 | 2" dia PVC Pipe | 2 | pc | 1 |
| 14 | 2" dia. PVC Elbow 45 deg. | 3 | pc | 1 |
| 15 | 2" dia. PVC Elbow 90 deg. | 3 | pc | 1 |
| 16 | 2" PVC Tee | 4 | pc | 1 |
| 17 | 2" PVC P-trap | 2 | pc | 1 |
| 18 | 1/2" dia. PPr pipe | 2 | pc | 1 |
| 19 | 1/2" dia. PPr elbow | 7 | pc | 1 |
| 20 | 1/2" dia. PPr tee | 4 | pc | 1 |

Handwritten signature/initials

**Procurement of CMU Boxes, Tools and Equipment and Mock-ups for
the Mobile Training Laboratories (MTLs).**

**TESDA Maguindanao 2 Provincial Office
Unit 1, 2nd Floor, ACB Residences, Notre dame
Avenue Cotabato City**

| No. | Item / Description | Qty. | Unit | No. of Mock-up |
|-----|--|------|------|----------------|
| 21 | 1/2" dia. PPr elbow connector | 6 | pc | 1 |
| 22 | 1/2" dia. PPr male connector | 2 | pc | 1 |
| 23 | 1/2" dia. PPr union | 3 | pc | 1 |
| 24 | 1/2" dia. PPr coupling | 4 | pc | 1 |
| 25 | Urinal 480mm X 730mm X 730mm with complete acces | 1 | unit | 1 |
| 26 | Shower head with complete accessories | 1 | unit | 1 |
| 27 | 1/2 x 7/8 flexible hose | 1 | pc | 1 |
| 28 | 1/2 x 1/2" angle valve | 3 | pc | 1 |
| 29 | 3/4" x 4' x 8' Marine Plywood | 1 | pc | 1 |
| 30 | 2" x 2" x 12' Lumber | 4 | pc | 1 |
| 31 | Teflon Tape | 10 | pc | 1 |
| 32 | Metal hinges 2" X 4", heavy duty | 3 | pc | 1 |

This include supplies and materials required in the fabrication of mock-up

Small Engine Repair (Motorcycle/Small Engine Servicing NC II) Tools and Equipment Mock-up

| | | | | |
|----|---|----|-------|---|
| 1 | Motorcycle/Small Engine Collapsible Mock-Up | 1 | lot | 1 |
| | SUPPLIES AND MATERIALS: | | | |
| 2 | Auto wire, stranded # 16 | 1 | roll | 1 |
| 3 | Electrical tape, large black | 2 | pc | 1 |
| 4 | Head light assembly, 12 volts rectangular | 1 | pc | 1 |
| 5 | signal light assembly, 12 volts | 2 | pair | 1 |
| 6 | Horn, 12 volts | 1 | pc | 1 |
| 7 | Stop light switch, push button | 1 | pc | 1 |
| 8 | Signal light switch, double throw, toggle switch | 1 | pc | 1 |
| 9 | Ignition switch, gas engine type | 1 | pc | 1 |
| 10 | Signal light relay, 12 volts | 1 | pc | 1 |
| 11 | Push button switch for horn | 1 | pc | 1 |
| 12 | Motorcycle storage battery, 12 volts maintenance free | 1 | pc | 1 |
| 13 | Harness cover, 3/8" diameter (140/4) | 4 | meter | 1 |
| 14 | Harness connector, 6 terminals | 4 | pc | 1 |
| 15 | Male terminal, flat | 30 | pc | 1 |
| 16 | Female terminal, flat | 30 | pc | 1 |
| 17 | Headlight switch or toggle switch, single throw | 1 | pc | 1 |
| 18 | Crocodile clip, medium, red and black | 1 | pair | 1 |
| 19 | 3/16" diameter X 3/4" stove bolt, stainless | 20 | pc | 1 |
| 20 | 3/16" diameter hole, eye terminal | 10 | pc | 1 |
| 21 | Four stroke motorcycle engine, 125 or 155cc, surplus | 1 | unit | 1 |

This include supplies and materials required in the fabrication of mock-up

Handwritten initials and numbers: 7, 2, M

Section VIII. Bidding Forms

TABLE OF CONTENTS

| | |
|--|-----------|
| BID FORM | 61 |
| CONTRACT AGREEMENT FORM..... | 65 |
| OMNIBUS SWORN STATEMENT | 66 |
| BANK GUARANTEE FORM FOR ADVANCE PAYMENT | 68 |

YN
08

Bid Form

Date: _____
Invitation to Bid¹ N^o: _____

To: *[name and address of Procuring Entity]*

Gentlemen and/or Ladies:

Having examined the Bidding Documents including Bid Bulletin Numbers *[insert numbers]*, the receipt of which is hereby duly acknowledged, we, the undersigned, offer to *[supply/deliver/perform]* *[description of the Goods]* in conformity with the said Bidding Documents for the sum of *[total Bid amount in words and figures]* or such other sums as may be ascertained in accordance with the Schedule of Prices attached herewith and made part of this Bid.

We undertake, if our Bid is accepted, to deliver the goods in accordance with the delivery schedule specified in the Schedule of Requirements.

If our Bid is accepted, we undertake to provide a performance security in the form, amounts, and within the times specified in the Bidding Documents.

We agree to abide by this Bid for the Bid Validity Period specified in **BDS** provision for ITB Clause 18.2 and it shall remain binding upon us and may be accepted at any time before the expiration of that period.

Commissions or gratuities, if any, paid or to be paid by us to agents relating to this Bid, and to contract execution if we are awarded the contract, are listed below:²

| Name and address of agent | Amount and Currency | Purpose of Commission or gratuity |
|---------------------------|---------------------|-----------------------------------|
| _____ | _____ | _____ |
| _____ | _____ | _____ |
| _____ | _____ | _____ |

(if none, state "None")

Until a formal Contract is prepared and executed, this Bid, together with your written acceptance thereof and your Notice of Award, shall be binding upon us.

We understand that you are not bound to accept the lowest or any Bid you may receive.

We certify/confirm that we comply with the eligibility requirements as per ITB Clause 5 of the Bidding Documents.

¹ If ADB, JICA and WB funded projects, use IFB.

² Applicable only if the Funding Source is the ADB, JICA or WB.

Dated this _____ day of _____ 20_____.

[signature]

[in the capacity of]

Duly authorized to sign Bid for and on behalf of _____

PN
96 of

For Goods Offered From Abroad

Name of Bidder _____ Invitation to Bid³ Number ____ Page ____ of _____

| 1 | 2 | 3 | 4 | 5 | 6 | 7 | 8 | 9 |
|------|-------------|-------------------|----------|---|--|--|--------------------------------------|---------------------------------------|
| Item | Description | Country of origin | Quantity | Unit price CIF port of entry (specify port) or CIF named place (specify border point or place of destination) | Total CIF or CIF price per item (col. 4 x 5) | Unit Price Delivered Duty Unpaid (DDU) | Unit price Delivered Duty Paid (DDP) | Total Price delivered DDP (col 4 x 8) |
| | | | | | | | | |

³ If ADB, JICA and WB funded projects, use IFB.

TN
9/15

For Goods Offered From Within the Philippines

Name of Bidder _____, Invitation to Bid⁴ Number __, Page of ____.

| 1 | 2 | 3 | 4 | 5 | 6 | 7 | 8 | 9 | 10 |
|------|-------------|-------------------|----------|-------------------------|---|--|--|---|---|
| Item | Description | Country of origin | Quantity | Unit price EXW per item | Cost of local labor, raw material, and component ² | Total price EXW per item (cols. 4 x 5) | Unit prices per item final destination and unit price of other incidental services | Sales and other taxes payable per item if Contract is awarded | Total Price delivered Final Destination (col 8 + 9) x 4 |
| | | | | | | | | | |

⁴ If ADB, JICA and WB funded projects, use IFB.

7 2/1/08

Contract Agreement Form

THIS AGREEMENT made the _____ day of _____ 20____ between *[name of PROCURING ENTITY]* of the Philippines (hereinafter called "the Entity") of the one part and *[name of Supplier]* of *[city and country of Supplier]* (hereinafter called "the Supplier") of the other part:

WHEREAS the Entity invited Bids for certain goods and ancillary services, viz., *[brief description of goods and services]* and has accepted a Bid by the Supplier for the supply of those goods and services in the sum of *[contract price in words and figures]* (hereinafter called "the Contract Price").

NOW THIS AGREEMENT WITNESSETH AS FOLLOWS:

1. In this Agreement words and expressions shall have the same meanings as are respectively assigned to them in the Conditions of Contract referred to.
2. The following documents shall be deemed to form and be read and construed as part of this Agreement, viz.:
 - (a) the Bid Form and the Price Schedule submitted by the Bidder;
 - (b) the Schedule of Requirements;
 - (c) the Technical Specifications;
 - (d) the General Conditions of Contract;
 - (e) the Special Conditions of Contract; and
 - (f) the Entity's Notification of Award.
3. In consideration of the payments to be made by the Entity to the Supplier as hereinafter mentioned, the Supplier hereby covenants with the Entity to provide the goods and services and to remedy defects therein in conformity in all respects with the provisions of the Contract
4. The Entity hereby covenants to pay the Supplier in consideration of the provision of the goods and services and the remedying of defects therein, the Contract Price or such other sum as may become payable under the provisions of the contract at the time and in the manner prescribed by the contract.

IN WITNESS whereof the parties hereto have caused this Agreement to be executed in accordance with the laws of the Republic of the Philippines on the day and year first above written.

Signed, sealed, delivered by _____ the _____ (for the Entity)

Signed, sealed, delivered by _____ the _____ (for the Supplier).

Omnibus Sworn Statement

REPUBLIC OF THE PHILIPPINES)
CITY/MUNICIPALITY OF _____) S.S.

AFFIDAVIT

I, *[Name of Affiant]*, of legal age, *[Civil Status]*, *[Nationality]*, and residing at *[Address of Affiant]*, after having been duly sworn in accordance with law, do hereby depose and state that:

1. *Select one, delete the other:*

If a sole proprietorship: I am the sole proprietor of *[Name of Bidder]* with office address at *[address of Bidder]*;

If a partnership, corporation, cooperative, or joint venture: I am the duly authorized and designated representative of *[Name of Bidder]* with office address at *[address of Bidder]*;

2. *Select one, delete the other:*

If a sole proprietorship: As the owner and sole proprietor of *[Name of Bidder]*, I have full power and authority to do, execute and perform any and all acts necessary to represent it in the bidding for *[Name of the Project]* of the *[Name of the Procuring Entity]*;

If a partnership, corporation, cooperative, or joint venture: I am granted full power and authority to do, execute and perform any and all acts necessary and/or to represent the *[Name of Bidder]* in the bidding as shown in the attached *[state title of attached document showing proof of authorization (e.g., duly notarized Secretary's Certificate issued by the corporation or the members of the joint venture)]*;

3. *[Name of Bidder]* is not "blacklisted" or barred from bidding by the Government of the Philippines or any of its agencies, offices, corporations, or Local Government Units, foreign government/foreign or international financing institution whose blacklisting rules have been recognized by the Government Procurement Policy Board;
4. Each of the documents submitted in satisfaction of the bidding requirements is an authentic copy of the original, complete, and all statements and information provided therein are true and correct;
5. *[Name of Bidder]* is authorizing the Head of the Procuring Entity or its duly authorized representative(s) to verify all the documents submitted;
6. *Select one, delete the rest:*

7 2
98
at

If a sole proprietorship: I am not related to the Head of the Procuring Entity, members of the Bids and Awards Committee (BAC), the Technical Working Group, and the BAC Secretariat, the head of the Project Management Office or the end-user unit, and the project consultants by consanguinity or affinity up to the third civil degree;

If a partnership or cooperative: None of the officers and members of *[Name of Bidder]* is related to the Head of the Procuring Entity, members of the Bids and Awards Committee (BAC), the Technical Working Group, and the BAC Secretariat, the head of the Project Management Office or the end-user unit, and the project consultants by consanguinity or affinity up to the third civil degree;

If a corporation or joint venture: None of the officers, directors, and controlling stockholders of *[Name of Bidder]* is related to the Head of the Procuring Entity, members of the Bids and Awards Committee (BAC), the Technical Working Group, and the BAC Secretariat, the head of the Project Management Office or the end-user unit, and the project consultants by consanguinity or affinity up to the third civil degree;

7. *[Name of Bidder]* complies with existing labor laws and standards; and
8. *[Name of Bidder]* is aware of and has undertaken the following responsibilities as a Bidder:
 - a) Carefully examine all of the Bidding Documents;
 - b) Acknowledge all conditions, local or otherwise, affecting the implementation of the Contract;
 - c) Made an estimate of the facilities available and needed for the contract to be bid, if any; and
 - d) Inquire or secure Supplemental/Bid Bulletin(s) issued for the *[Name of the Project]*.
9. *[Name of Bidder]* did not give or pay directly or indirectly, any commission, amount, fee, or any form of consideration, pecuniary or otherwise, to any person or official, personnel or representative of the government in relation to any procurement project or activity.

IN WITNESS WHEREOF, I have hereunto set my hand this ___ day of ___, 20__ at _____, Philippines.

Bidder's Representative/Authorized Signatory

[JURAT]

* This form will not apply for WB funded projects.

12
92
etc

Bank Guarantee Form for Advance Payment

To: *[name and address of PROCURING ENTITY]*
[name of Contract]

Gentlemen and/or Ladies:

In accordance with the payment provision included in the Special Conditions of Contract, which amends Clause 10 of the General Conditions of Contract to provide for advance payment, *[name and address of Supplier]* (hereinafter called the "Supplier") shall deposit with the PROCURING ENTITY a bank guarantee to guarantee its proper and faithful performance under the said Clause of the Contract in an amount of *[amount of guarantee in figures and words]*.

We, the *[bank or financial institution]*, as instructed by the Supplier, agree unconditionally and irrevocably to guarantee as primary obligator and not as surety merely, the payment to the PROCURING ENTITY on its first demand without whatsoever right of objection on our part and without its first claim to the Supplier, in the amount not exceeding *[amount of guarantee in figures and words]*.

We further agree that no change or addition to or other modification of the terms of the Contract to be performed thereunder or of any of the Contract documents which may be made between the PROCURING ENTITY and the Supplier, shall in any way release us from any liability under this guarantee, and we hereby waive notice of any such change, addition, or modification.

This guarantee shall remain valid and in full effect from the date of the advance payment received by the Supplier under the Contract until *[date]*.

Yours truly,

Signature and seal of the Guarantors

[name of bank or financial institution]

[address]

[date]

*YN
get
df*

1 N of
as